

## High-Power Step-Down LED Driver Supports Wide Range of PWM Dimming Interfaces

### 1 Description

The iW3638 is a high-performance second-stage buck LED driver optimized to supply constant-current to LEDs directly from DC power supplies typically below 100V. The controller supports a non-isolated buck-converter topology to post-regulate from an off-line AC/DC converter, minimizing low frequency output ripple current and eliminating virtually all flicker in the system. It uses Dialog's **PrimAccurate™** advanced sensing technology to achieve excellent output current regulation without the need for direct voltage and current feedback components. It also eliminates the need for external loop compensation while maintaining stability across all operating conditions.

The iW3638 offers a 1% to 100% dimming range and provides a dedicated PWM dimming input pin that supports a wide variety of dimming application interfaces such as wireless modules, MCUs or 0-10V interfaces. In addition, the iW3638 accepts a secondary dimming input pin to allow maximum output current configuration.

Dialog's innovative proprietary technology maximizes the iW3638 performance in an SOIC-8 package. It provides maximum design flexibility by providing two multi-function pins to configure IC functions such as the dimming curve and minimum dimming level. Additionally, the iW3638 features a soft-off function before entering into light-off mode, where the device remains alive with minimal standby power consumption.

### 2 Features

- Supports wide DC input voltage with tight output current regulation ( $\pm 3\%$ )
- Enhanced MOSFET driver supports output power up to 90W or above in an SOIC-8 package
- Dual dimming interfaces
- Low standby power
- Supports 0-10V dimming with the iW339 series interface controllers
- Wide dimming range 1% - 100%
- Configurable minimum dimming setting: dim-to-off, 1%, 5% or 10%
- Wide  $V_{CC}$  operating range from 7.5V to 30V
- Fast dimming transient response
- Built-in over-temperature protection or by external NTC
- Configurable dimming curve: linear or logarithmic
- Built-in soft-start achieves fast and smooth start-up for all different operating conditions
- Built-in single-point fault protection features: output open, output over-voltage, output short and input voltage under-voltage protections
- Light-off mode with soft-off feature

### 3 Applications

- 0-10V dimmable LED drivers
- Dimmable commercial T8
- External and fixture driver lighting applications
- Wireless and intelligent LED lighting

High-Power Step-Down LED Driver Supports Wide Range of PWM Dimming Interfaces

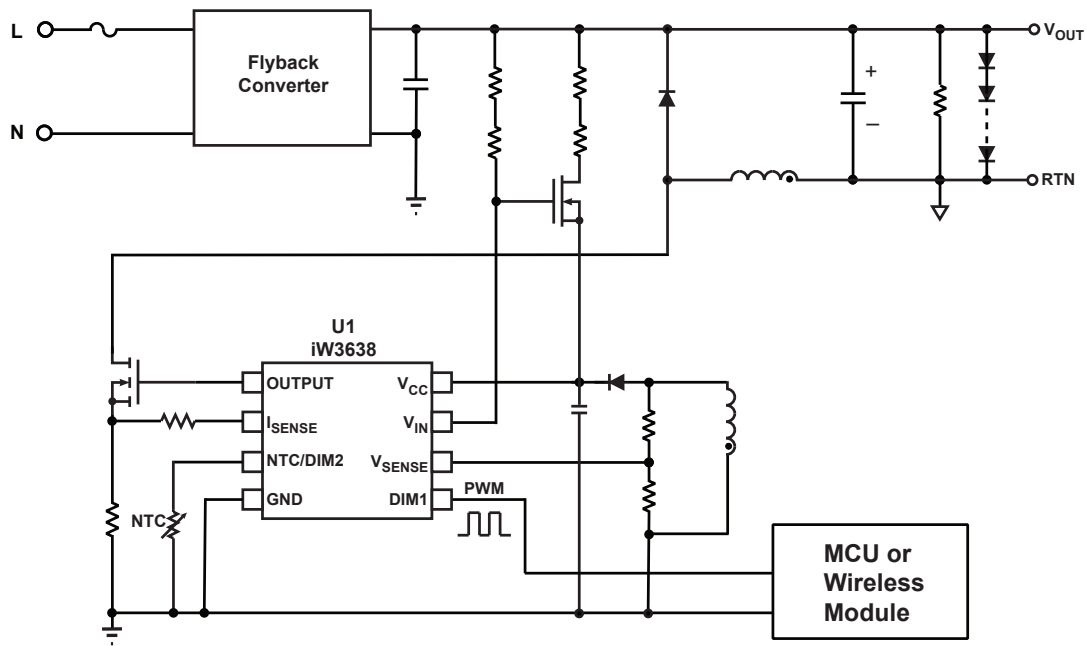

Figure 3.1 : iW3638 Typical Application Circuit (Wireless Dimming with NTC Derating Using Depletion-mode FET as Active Start-up Device)

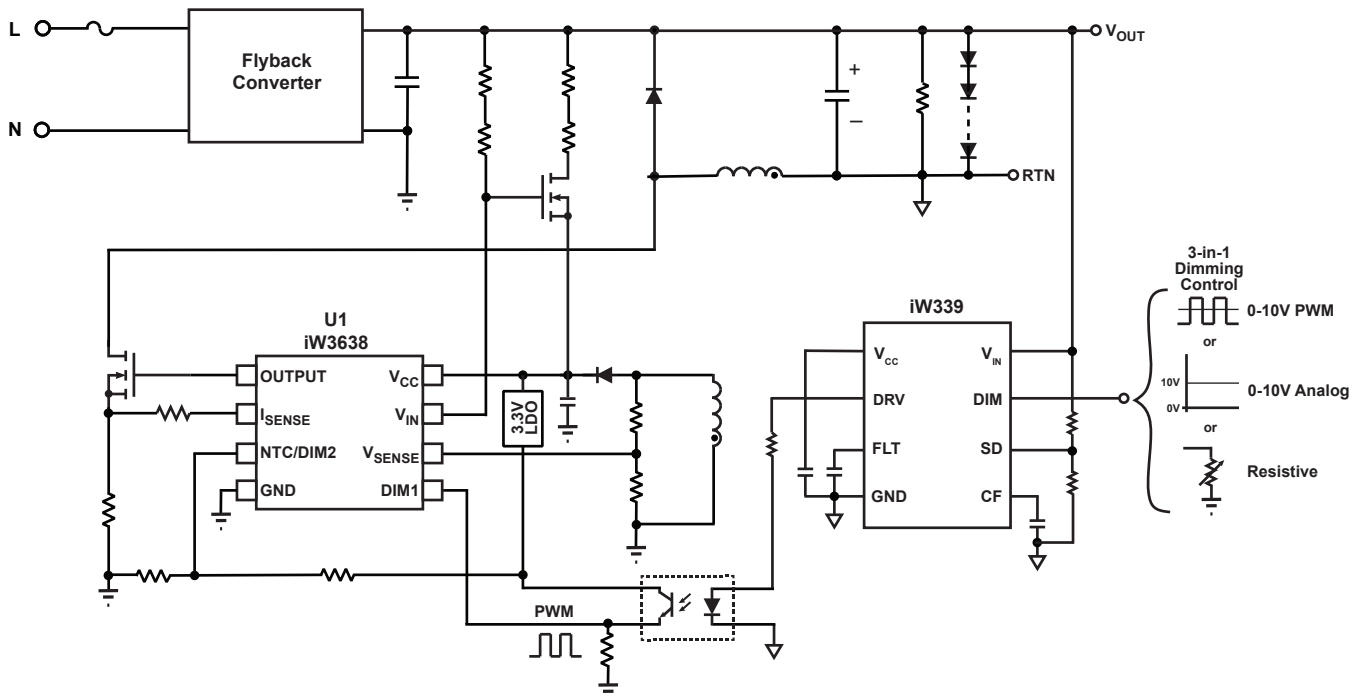

Figure 3.2 : iW3638 Typical Application Circuit (3-in-1 Dimming with Maximum Current Modulated by the Voltage at NTC/ DIM2 Pin and Using Enhancement-mode FET as Active Start-up Device)

## High-Power Step-Down LED Driver Supports Wide Range of PWM Dimming Interfaces

### 4 Pinout Description

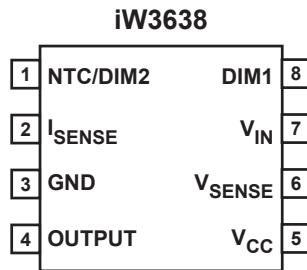

Figure 4.1 : 8-Lead SOIC-8 Package

Pin Number	Pin Name	Type	Pin Description
1	NTC/DIM2	Digital Input / Analog In/Out	Used for external temperature sensing via an NTC resistor, or to provide a second dimming interface via an analog signal (0-1.8V).
2	I <sub>SENSE</sub>	Analog Input	Provides switch current sense for cycle-by-cycle peak current control and limit during normal operation, and serves as a configuration pin during startup.
3	GND	Ground	Ground.
4	OUTPUT	Output	Gate drive for external MOSFET switch.
5	V <sub>CC</sub>	Power	IC power supply.
6	V <sub>SENSE</sub>	Analog Input	Provides output voltage sense during normal operation, and serves as a configuration pin during startup.
7	V <sub>IN</sub>	Analog Input	Control active start-up devices and sense input bus voltage.
8	DIM1	Digital Input	PWM dimming input detection.

## High-Power Step-Down LED Driver Supports Wide Range of PWM Dimming Interfaces

### 5 Absolute Maximum Ratings

Absolute maximum ratings are the parameter values or ranges which can cause permanent damage if exceeded.

Parameter	Symbol	Value	Units
DC supply voltage range (pin 5, $I_{CC} = 10\text{mA max}$ )	$V_{CC}$	-0.3 to 31	V
Continuous DC supply current at $V_{CC}$ pin	$I_{CC}$	20	mA
$V_{IN}$ (pin 7)		-0.3 to 31	V
OUTPUT (pin 4)		-0.3 to 31	V
$V_{SENSE}$ input (pin 6, $I_{VSENSE} \leq 10\text{mA}$ )		-0.3 to 7	V
$I_{SENSE}$ input (pin 2)		-0.3 to 7	V
NTC/DIM2 (pin 1)		-0.3 to 7	V
DIM1 (pin 8)		-0.3 to 7	V
Maximum junction temperature	$T_{JMAX}$	150	°C
Operating junction temperature	$T_{JOPT}$	-40 to 150	°C
Storage temperature	$T_{STG}$	-65 to 150	°C
Thermal resistance junction-to-ambient	$\theta_{JA}$	170	°C/W
ESD rating per JEDEC JESD22-A114		$\pm 2,000$	V
Latch-up test per JESD78D		$\pm 100$	mA

## High-Power Step-Down LED Driver Supports Wide Range of PWM Dimming Interfaces

### 6 Physical Dimensions

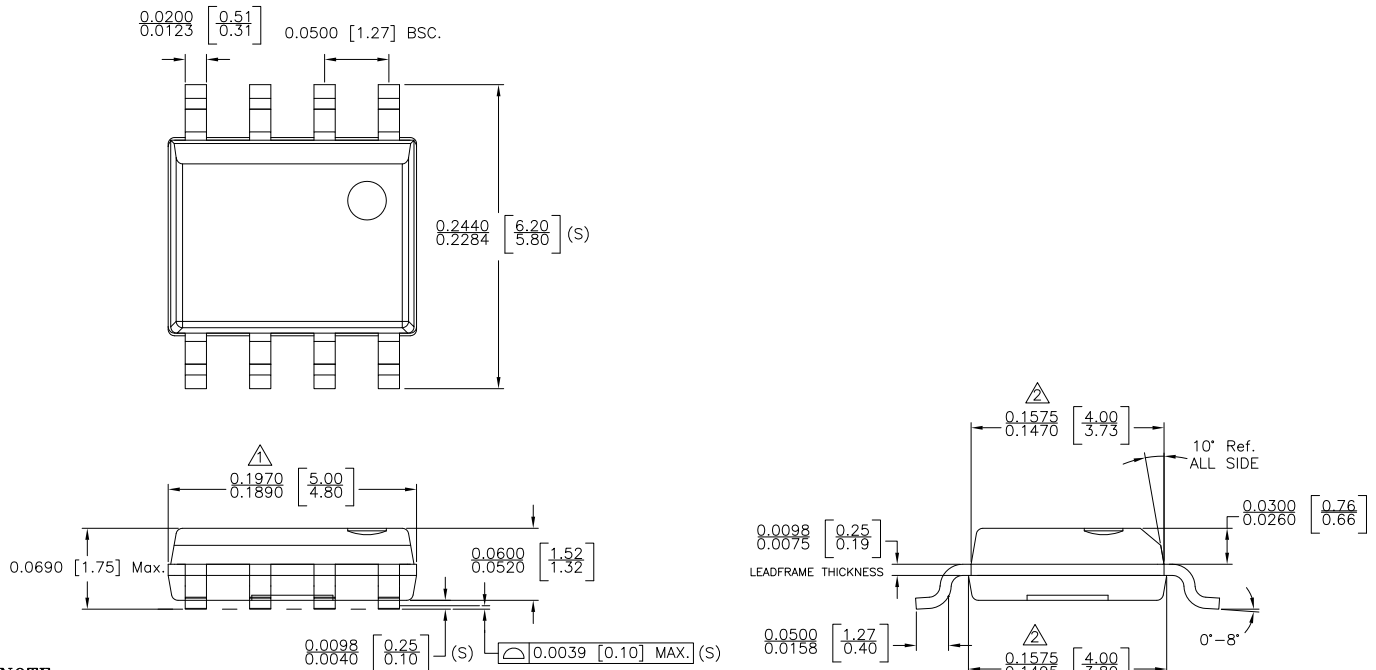

**NOTE :**

- 1. DOES NOT INCLUDE MOLD FLASH, PROTRUSIONS OR GATE BURRS. MOLD FLASH, PROTRUSIONS AND GATE BURRS SHALL NOT EXCEED .006 INCH PER SIDE.
- 2. DOES NOT INCLUDE INTER-LEAD FLASH OR PROTRUSIONS. INTER-LEAD FLASH AND PROTRUSIONS SHALL NOT EXCEED .010 INCH PER SIDE.
- 3. THIS PART IS COMPLIANT WITH JEDEC SPECIFICATION MS-012.
- 4. LEAD SPAN/STAND OFF HEIGHT/COPLANARITY ARE CONSIDERED AS SPECIAL CHARACTERISTIC.(S)
- 5. CONTROLLING DIMENSIONS IN INCHES. [mm]

STATUS: RELEASED	SCALE: DO NOT SCALE
TERMINAL FINISH: 100% Sn or NiPdAu (PPF)	
TITLE: 8 SOIC PACKAGE OUTLINE	
REV: A	DATE: 02-MAR-2015

### 7 Ordering Information

Part no.	Options	Package	Description
iW3638-02	NTC DIM2 interface	SOIC-8	Tape & Reel <sup>1</sup>
iW3638-03	Analog DIM2 interface	SOIC-8	Tape & Reel <sup>1</sup>

Note 1: Tape and reel packing quantity is 2,500/reel. Minimum ordering quantity is 2,500.

## High-Power Step-Down LED Driver Supports Wide Range of PWM Dimming Interfaces

### Disclaimer

Information in this document is believed to be accurate and reliable. However, Dialog Semiconductor does not give any representations or warranties, expressed or implied, as to the accuracy or completeness of such information. Dialog Semiconductor furthermore takes no responsibility whatsoever for the content in this document if provided by any information source outside of Dialog Semiconductor.

Dialog Semiconductor reserves the right to change without notice the information published in this document, including without limitation the specification and the design of the related semiconductor products, software and applications.

Applications, software, and semiconductor products described in this document are for illustrative purposes only. Dialog Semiconductor makes no representation or warranty that such applications, software and semiconductor products will be suitable for the specified use without further testing or modification. Unless otherwise agreed in writing, such testing or modification is the sole responsibility of the customer and Dialog Semiconductor excludes all liability in this respect.

Customer notes that nothing in this document may be construed as a license for customer to use the Dialog Semiconductor products, software and applications referred to in this document. Such license must be separately sought by customer with Dialog Semiconductor.

All use of Dialog Semiconductor products, software and applications referred to in this document are subject to [Dialog Semiconductor's Standard Terms and Conditions of Sale](#), available on the company website ([www.dialog-semiconductor.com](http://www.dialog-semiconductor.com)) unless otherwise stated.

Dialog and the Dialog logo are trademarks of Dialog Semiconductor plc or its subsidiaries. All other product or service names are the property of their respective owners.

© 2017 Dialog Semiconductor. All rights reserved.

### RoHS Compliance

Dialog Semiconductor's suppliers certify that its products are in compliance with the requirements of Directive 2011/65/EU of the European Parliament on the restriction of the use of certain hazardous substances in electrical and electronic equipment. RoHS certificates from our suppliers are available on request.

## Contacting Dialog Semiconductor

**United Kingdom (Headquarters)**  
Dialog Semiconductor (UK) LTD  
Phone: +44 1793 757700

**Germany**  
Dialog Semiconductor GmbH  
Phone: +49 7021 805-0

**The Netherlands**  
Dialog Semiconductor B.V.  
Phone: +31 73 640 8822

**Email**  
[info\\_pcbg@diasemi.com](mailto:info_pcbg@diasemi.com)

**North America**  
Dialog Semiconductor Inc.  
Phone: +1 408 845 8500

**Japan**  
Dialog Semiconductor K. K.  
Phone: +81 3 5769 5100

**Taiwan**  
Dialog Semiconductor Taiwan  
Phone: +886 281 786 222

**Web site:**  
[www.dialog-semiconductor.com](http://www.dialog-semiconductor.com)

**Hong Kong**  
Dialog Semiconductor Hong Kong  
Phone: +852 2607 4271

**Korea**  
Dialog Semiconductor Korea  
Phone: +82 2 3469 8200

**China (Shenzhen)**  
Dialog Semiconductor China  
Phone: +86 755 2981 3669

**China (Shanghai)**  
Dialog Semiconductor China  
Phone: +86 21 5424 9058

## X-ON Electronics

Largest Supplier of Electrical and Electronic Components

*Click to view similar products for [LED Display Drivers](#) category:*

*Click to view products by [Dialog Semiconductor](#) manufacturer:*

Other Similar products are found below :

[MAP9000QNRH](#) [AP5726WUG-7](#) [AL8806QMP-13](#) [AP5726FDCG-7](#) [AS3693B-ZTQT](#) [AP5725WUG-7](#) [MAX139EQH+D](#) [STP16DP05PTR](#)  
[STP16CPP05PTR](#) [STP16CPP05XTTR](#) [LV5236VZ-TLM-H](#) [BP9911CC](#) [ZXLD1366QEN8TC](#) [MT7725D](#) [TX6143](#) [SY6813PEC](#) [SD1002L4](#)  
[AW3643CSR](#) [MP3370GN-Z](#) [LA2284L-G09-T](#) [SEDA](#) [SCT2027CSSG](#) [LYT3315D](#) [LYT3324D](#) [LYT4211E2](#) [LYT4214E2](#) [LYT4215E2](#)  
[LYT4217E2](#) [LYT4218E2](#) [LYT4222E](#) [LYT4317E2](#) [LYT4321E](#) [LYT4323E](#) [LYT4324E3](#) [LYT4326E3](#) [TPS92020DR](#) [TPS92691PWPR](#)  
[BCR420U](#) [HV9801ALG-G](#) [IS31FL3199-QFLS2-TR](#) [IS31FL3731-QFLS2-TR](#) [CAT4238TD](#) [SCT2001ASIG](#) [SCT2024CSTG](#) [SCT2167CSOG](#)  
[SCT2167CSSG](#) [STP16CPPS05XTTR](#) [TLE4241GMFUMA1](#) [ICM7212MIQH+D](#) [ICM7212AIQH+D](#)