

Single-Stage SSL LED Driver with Integrated High Voltage MOSFET for Dimmable Retrofit Lamps up to 15W

1 Description

The iW3658 is a highly integrated, high-performance off-line power supply controller for phase-cut dimmable LED luminaires. It uses patented **PrimAccurate™** primary-side sensing technology to regulate output current accurately without the need for a feedback circuit. The iW3658 operates at boundary conduction mode to achieve high efficiency and low EMI.

With advanced dimming control technology, the iW3658 can operate with most wall dimmers including leading-edge dimmers (R-type or R-L type) and trailing-edge dimmers (R-C type). The iW3658 operates in buck-boost mode to regulate current to the output LEDs.

Dialog's innovative technology maximizes the iW3658 performance with an integrated high-voltage MOSFET in an SO-7 package, which provides an extra pin spacing between the high voltage MOSFET's drain and low voltage pins. With Dialog's proprietary V_{CC} regulation circuit, the iW3658's V_{CC} level is well maintained regardless of the LED voltage and dimmer phase angle, which eliminates the possibility of low end flickering.

2 Features

- Isolated/non-isolated off-line $120V_{AC}/230V_{AC}$ LED driver up to 15W (Note 1)
- Wide line frequency range (45Hz – 66Hz)
- Excellent dimmer compatibility
 - » Leading-edge dimmer
 - » Trailing-edge dimmer
- Low BOM cost
- Integrated high-voltage MOSFET
- Single-winding inductor
- Internal start-up without the need for high voltage circuit
- Closed-loop constant current regulation
- Built-in LED current derating at high temperature
- Built-in over-temperature shut-down
- LED open and short protection
- Fast start-up (< 0.5s without dimmer)
- Resonant control to achieve high efficiency (typical > 85%)
- Supports Buck-Boost topology

3 Applications

- Dimmable LED retrofit lamps up to 15W (Note 1)
 - » A-style, BR, GU and PAR
- Fits in E26/27 Socket for All-Glass Lamps

Single-Stage SSL LED Driver with Integrated High Voltage MOSFET for Dimmable Retrofit Lamps up to 15W

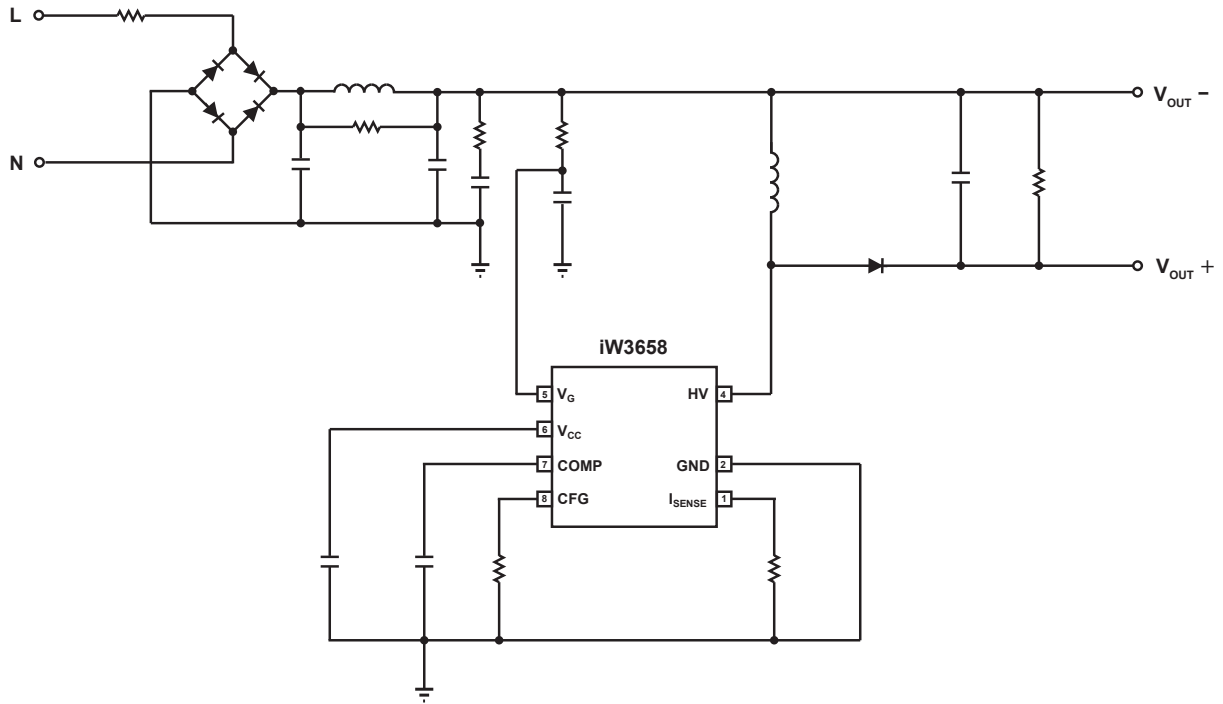

Figure 3.1 : iW3658 Typical Application Circuit

Note 1 : For output power above 12W designs, care should be taken to verify the thermal and reliability constraints on the IC. An IC temperature below 120°C is recommended for proper IC operation.

Single-Stage SSL LED Driver with Integrated High Voltage MOSFET for Dimmable Retrofit Lamps up to 15W

4 Pinout Description

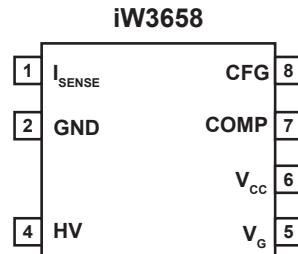

Figure 4.1 : 7-Lead SO Package

Pin Number	Pin Name	Type	Pin Description
1	I_{SENSE}	Analog	Current sense
2	GND	Ground	Ground reference
4	HV	Analog	Internal high voltage MOSFET drain
5	V_G	Analog	Internal high voltage MOSFET gate
6	V_{CC}	Power Input	Power supply to control logic and MOSFET drive
7	COMP	Analog	Constant current regulation loop compensation
8	CFG	Analog	OVP level configuration

Single-Stage SSL LED Driver with Integrated High Voltage MOSFET for Dimmable Retrofit Lamps up to 15W

5 Absolute Maximum Ratings

Absolute maximum ratings are the parameter values or ranges which can cause permanent damage if exceeded.

Parameter	Symbol	Value	Units
DC supply voltage range (pin 6)	V_{CC}	-0.3 to 6.0	V
V_G (pin 5)		-0.3 to 18.0	V
COMP (pin 7)		-0.3 to 6.0	V
HV (pin 4)		500 or 650	V
I_{SENSE} (pin 1)		-0.3 to 6.0	V
CFG (pin 8)		-0.3 to 6.0	V
Maximum junction temperature	T_{JMAX}	150	°C
Operating junction temperature	T_{JOPT}	-40 to 150	°C
Storage temperature	T_{STG}	-65 to 150	°C
Thermal resistance junction-to-ambient	θ_{JA}	170	°C/W
ESD rating per JEDEC JS-001-2017		± 2000	V
Latch-up test per JESD78E		± 100	mA

Single-Stage SSL LED Driver with Integrated High Voltage MOSFET for Dimmable Retrofit Lamps up to 15W

6 Physical Dimensions

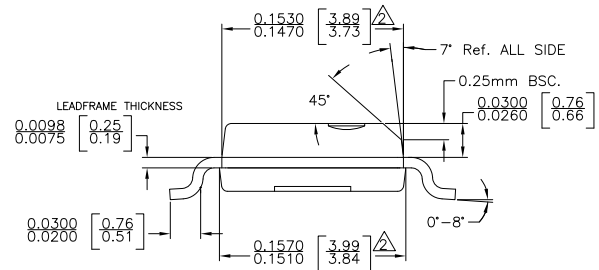
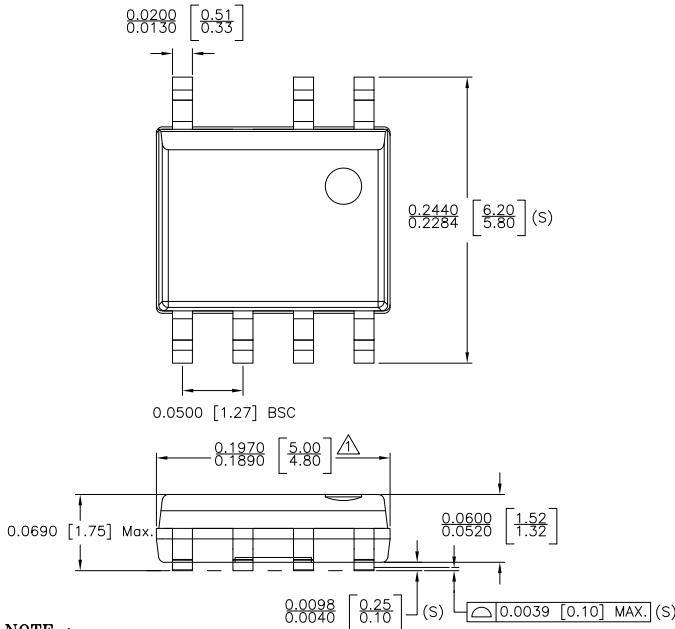

NOTE :

- 1. DOES NOT INCLUDE MOLD FLASH, PROTRUSIONS OR GATE BURRS. MOLD FLASH, PROTRUSIONS AND GATE BURRS SHALL NOT EXCEED .006 INCH PER SIDE.
- 2. DOES NOT INCLUDE INTER-LEAD FLASH OR PROTRUSIONS. INTER-LEAD FLASH AND PROTRUSIONS SHALL NOT EXCEED .010 INCH PER SIDE.
- 3. PACKAGE DIMENSION CONFORM TO JEDEC SPECIFICATION MS-012
- 4. LEAD SPAN/STAND OFF HEIGHT/COPLANARITY ARE CONSIDERED AS SPECIAL CHARACTERISTIC(S)
- 5. CONTROLLING DIMENSIONS IN INCHES.[mm]

STATUS: RELEASED	SCALE: DO NOT SCALE
TERMINAL FINISH: 100% Sn or NiPdAu (PPF)	
TITLE: 7 SOIC (NO PIN 3) PACKAGE OUTLINE	
REV: C	REVISION NOTE: ADD PACKAGE CHAMFER
DATE: 01-JUNE-2015	

Single-Stage SSL LED Driver with Integrated High Voltage MOSFET for Dimmable Retrofit Lamps up to 15W

7 Ordering Information

Part no.	Options	Package	Description
iW3658-00C ¹ iW3658-00D ¹ iW3658-00F	120V _{AC} Input, 500V/3A MOSFET	SO-7	Tape & Reel ²
iW3658-06D ¹ iW3658-06F	120V _{AC} Input, 500V/2A MOSFET	SO-7	Tape & Reel ²
iW3658-20 ¹ iW3658-20D ¹ iW3658-20F	120V _{AC} Input, 500V/3A MOSFET, optimized for high power factor	SO-7	Tape & Reel ²
iW3658-21 ¹ iW3658-21D ¹ iW3658-21F	230V _{AC} Input, 650V/2A MOSFET, optimized for high power factor	SO-7	Tape & Reel ²
iW3658-26D ¹ iW3658-26F	120V _{AC} Input, 500V/2A MOSFET, optimized for high power factor	SO-7	Tape & Reel ²
iW3658-30 ¹ iW3658-30D ¹ iW3658-30F	120V _{AC} Input, 500V/3A MOSFET, optimized for filament load	SO-7	Tape & Reel ²
iW3658-31 ¹ iW3658-31D ¹ iW3658-31F	230V _{AC} Input, 650V/2A MOSFET, optimized for filament load	SO-7	Tape & Reel ²
iW3658-36D ¹ iW3658-36F	120V _{AC} Input, 500V/2A MOSFET, optimized for filament load	SO-7	Tape & Reel ²

Note 1: Not recommended for new designs; use the -xxF version.

Note 2: Tape and reel packing quantity is 2,500/reel. Minimum packing quantity is 2,500.

Single-Stage SSL LED Driver with Integrated High Voltage MOSFET for Dimmable Retrofit Lamps up to 15W

Disclaimer

Information in this document is believed to be accurate and reliable. However, Dialog Semiconductor does not give any representations or warranties, expressed or implied, as to the accuracy or completeness of such information. Dialog Semiconductor furthermore takes no responsibility whatsoever for the content in this document if provided by any information source outside of Dialog Semiconductor.

Dialog Semiconductor reserves the right to change without notice the information published in this document, including without limitation the specification and the design of the related semiconductor products, software and applications.

Applications, software, and semiconductor products described in this document are for illustrative purposes only. Dialog Semiconductor makes no representation or warranty that such applications, software and semiconductor products will be suitable for the specified use without further testing or modification. Unless otherwise agreed in writing, such testing or modification is the sole responsibility of the customer and Dialog Semiconductor excludes all liability in this respect.

Customer notes that nothing in this document may be construed as a license for customer to use the Dialog Semiconductor products, software and applications referred to in this document. Such license must be separately sought by customer with Dialog Semiconductor.

All use of Dialog Semiconductor products, software and applications referred to in this document are subject to [Dialog Semiconductor's Standard Terms and Conditions of Sale](#), available on the company website (www.dialog-semiconductor.com) unless otherwise stated.

Dialog and the Dialog logo are trademarks of Dialog Semiconductor plc or its subsidiaries. All other product or service names are the property of their respective owners.

© 2018 Dialog Semiconductor. All rights reserved.

RoHS Compliance

Dialog Semiconductor's suppliers certify that its products are in compliance with the requirements of Directive 2011/65/EU of the European Parliament on the restriction of the use of certain hazardous substances in electrical and electronic equipment. RoHS certificates from our suppliers are available on request.

Contacting Dialog Semiconductor

United Kingdom (Headquarters)
Dialog Semiconductor (UK) LTD
Phone: +44 1793 757700

Germany
Dialog Semiconductor GmbH
Phone: +49 7021 805-0

The Netherlands
Dialog Semiconductor B.V.
Phone: +31 73 640 8822

Email
info_pcbg@diasemi.com

North America
Dialog Semiconductor Inc.
Phone: +1 408 845 8500

Japan
Dialog Semiconductor K. K.
Phone: +81 3 5769 5100

Taiwan
Dialog Semiconductor Taiwan
Phone: +886 281 786 222

Web site:
www.dialog-semiconductor.com

Hong Kong
Dialog Semiconductor Hong Kong
Phone: +852 2607 4271

Korea
Dialog Semiconductor Korea
Phone: +82 2 3469 8200

China (Shenzhen)
Dialog Semiconductor China
Phone: +86 755 2981 3669

China (Shanghai)
Dialog Semiconductor China
Phone: +86 21 5424 9058

X-ON Electronics

Largest Supplier of Electrical and Electronic Components

Click to view similar products for [LED Display Drivers](#) category:

Click to view products by [Dialog Semiconductor](#) manufacturer:

Other Similar products are found below :

[MAP9000QNRH](#) [AP5726WUG-7](#) [AL8806QMP-13](#) [AP5726FDCG-7](#) [AS3693B-ZTQT](#) [AP5725WUG-7](#) [MAX139EQH+D](#) [STP16DP05PTR](#)
[STP16CPP05PTR](#) [STP16CPP05XTTR](#) [LV5236VZ-TLM-H](#) [BP9911CC](#) [ZXLD1366QEN8TC](#) [MT7725D](#) [TX6143](#) [SY6813PEC](#) [SD1002L4](#)
[AW3643CSR](#) [MP3370GN-Z](#) [LA2284L-G09-T](#) [SEDA](#) [SCT2027CSSG](#) [LYT3315D](#) [LYT3324D](#) [LYT4211E2](#) [LYT4214E2](#) [LYT4215E2](#)
[LYT4217E2](#) [LYT4218E2](#) [LYT4222E](#) [LYT4317E2](#) [LYT4321E](#) [LYT4323E](#) [LYT4324E3](#) [LYT4326E3](#) [TPS92020DR](#) [TPS92691PWPR](#)
[BCR420U](#) [HV9801ALG-G](#) [IS31FL3199-QFLS2-TR](#) [IS31FL3731-QFLS2-TR](#) [CAT4238TD](#) [SCT2001ASIG](#) [SCT2024CSTG](#) [SCT2167CSOG](#)
[SCT2167CSSG](#) [STP16CPPS05XTTR](#) [TLE4241GMFUMA1](#) [ICM7212MIQH+D](#) [ICM7212AIQH+D](#)