

Digital AC Direct Power Controller for Phase-Cut Dimmable LED Luminaires

1 Description

The iW3989 is a high performance AC direct power controller for dimmable LED luminaires. It applies advanced digital control technology to detect the dimmer type, enabling it to provide dynamic impedance to interface with the dimmer and to control the LED brightness at the same time.

With advanced dimmer detection technology, the iW3989 can operate with most wall dimmers including leading-edge dimmers (R-type or R-L type), trailing-edge dimmers (R-C type), and smart dimmers. In addition, the iW3989's cycle-by-cycle waveform analysis technology allows for fast dimmer transient response.

The iW3989 achieves excellent closed-loop LED current regulation under different AC line and LED forward voltages. It provides high efficiency that is close to switch-mode controllers, which solves the thermal challenges in most AC direct driven luminaires. By eliminating the inductive components, the iW3989 eliminates the audible noise when working with TRIAC dimmers, enabling a true incandescent-like lighting experience. The iW3989 also uses proprietary digital technology to enhance the immunity to line distortion, makes it a robust, flicker-free solution in harsh AC line environments.

The iW3989 minimizes the external components count by simplifying the EMI design with Dialog's **EZ-EMI**[®] technology, and by integrating the LED current sink and V_{CC} charging circuit.

2 Features

- Non-isolated off-line 120V_{AC} LED driver
- Wide AC line frequency range (from 45Hz to 66Hz)
- High power factor > 0.7 or > 0.9
- Excellent dimmer compatibility
 - » Leading-edge dimmer
 - » Trailing-edge dimmer
 - » Digital smart dimmer
- Wide dimming range
- No external V_{CC} charging needed - reduces BOM cost
- Excellent immunity to AC line distortion
- Tight LED current regulation
- Fast start-up (< 0.5s without dimmer)
- Multiple protection features:
 - » LED open-circuit and short-circuit
 - » Current setting resistor open-circuit and short-circuit
 - » Over-temperature derating and thermal shutdown

3 Applications

- Dimmable LED retrofit lamps up to 15W (Note 1)
- Dimmable LED Luminaires up to 15W (Note 1)

Digital AC Direct Power Controller for Phase-Cut Dimmable LED Luminaires

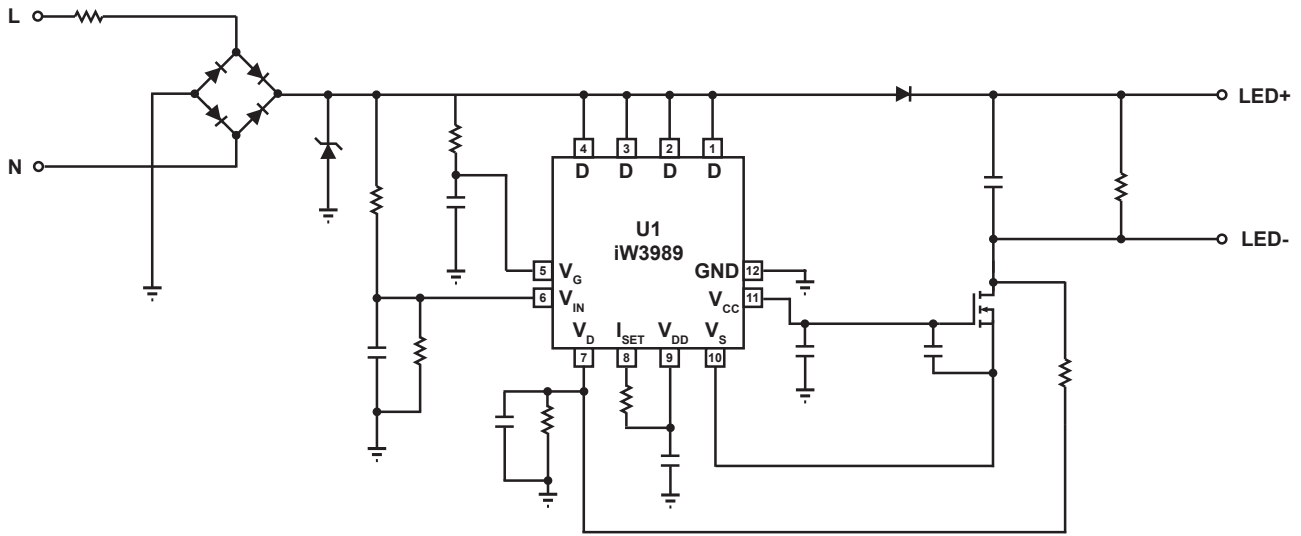

Figure 3.1 : iW3989 Typical Application Circuit

Note 1: For output power above 10W designs, care should be taken to verify the thermal and reliability constraints on the IC. IC temperature below 120°C is recommended for proper IC operation.

Digital AC Direct Power Controller for Phase-Cut Dimmable LED Luminaires

4 Pinout Description

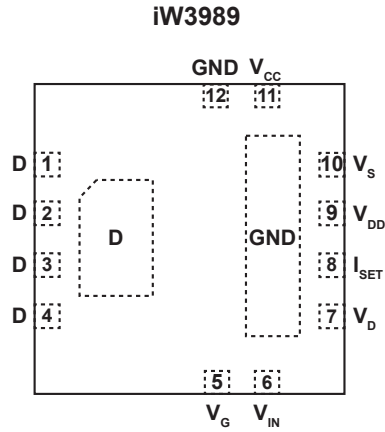

Figure 4.1 : 12-Lead QFN Package Top View (Transparent)

Pin Number QFN-12	Pin Name	Type	Pin Description
1-4	D	Analog Input	Internal high voltage MOSFET drain.
5	V_G	Analog Input	Internal high voltage MOSFET gate.
6	V_{IN}	Analog Input	Rectified AC line voltage sense.
7	V_D	Analog Input	External MOSFET drain voltage sense.
8	I_{SET}	Analog Input	LED current setting.
9	V_{DD}	Power	Power supply for control logic.
10	V_S	Analog Input	External MOSFET source pin.
11	V_{CC}	Power	External MOSFET gate bias.
12	GND	Ground	Ground.

Digital AC Direct Power Controller for Phase-Cut Dimmable LED Luminaires

5 Absolute Maximum Ratings

Absolute maximum ratings are the parameter values or ranges which can cause permanent damage if exceeded.

Parameter	Symbol	Value	Units
D		500	V
V _G		-0.3 to 30	V
V _{IN}		-0.3 to 7	V
V _D		-0.3 to 7	V
V _{DD}		-0.3 to 7	V
I _{SET}		-0.3 to 7	V
V _S		-0.3 to 12	V
V _{CC}		-0.3 to 12	V
ESD Rating (HBM)		±2000	V
Storage temperature range		-65 to +150	°C
Maximum junction temperature		150	°C

Note 1: Stresses beyond those listed under Absolute Maximum Ratings may cause permanent damage to the device. These are stress ratings only, so functional operation of the device at these or any other conditions beyond those indicated in the operational sections of the specification are not implied. Exposure to absolute maximum rating conditions for extended periods may affect device reliability.

Digital AC Direct Power Controller for Phase-Cut Dimmable LED Luminaires

6 Physical Dimensions

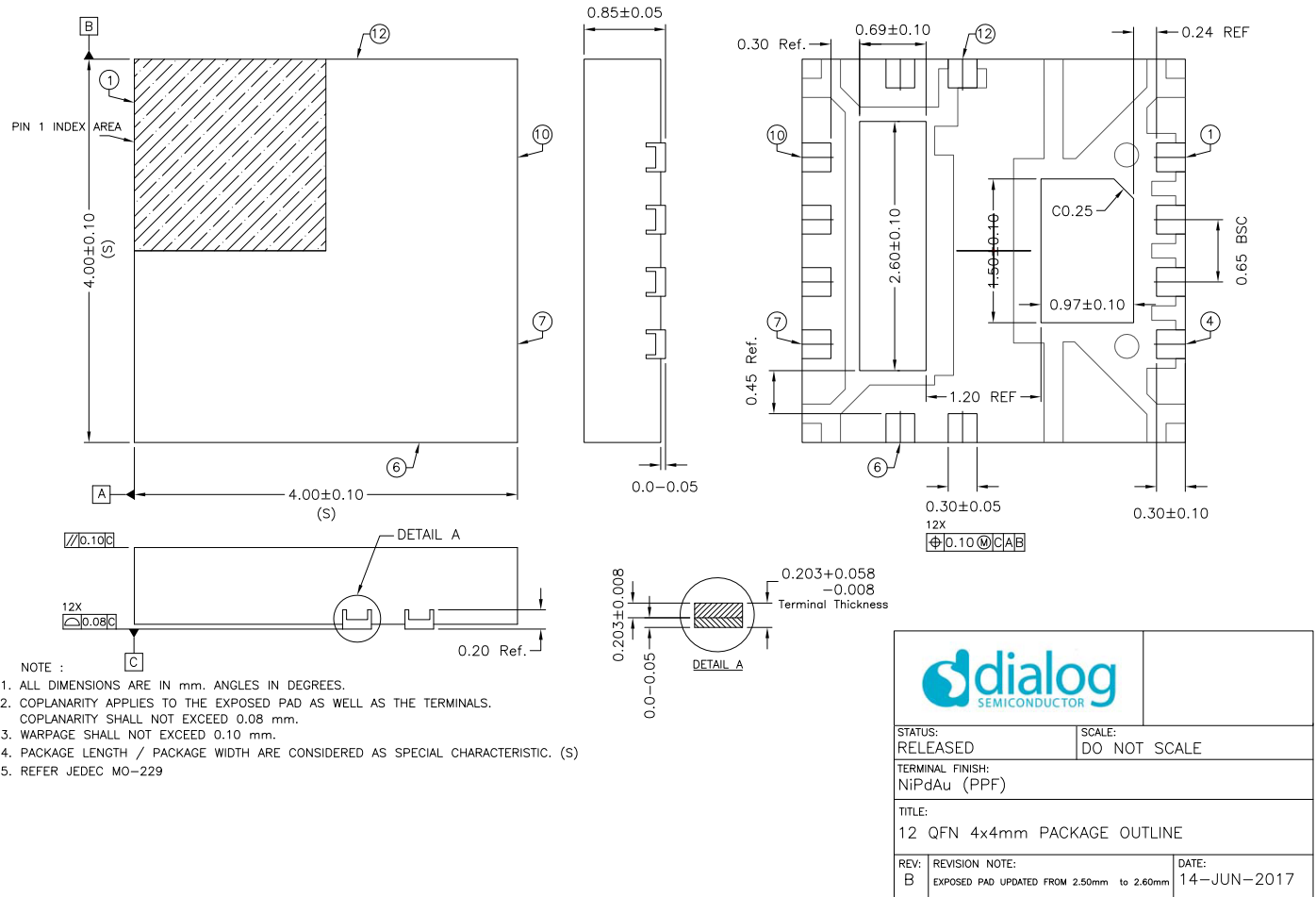

Figure 6.1 : Physical Dimension of QFN Package

7 Ordering Information

Part Number	Options		Package	Description
	Optimized Output Power Range	Power Factor		
iW3989-00	up to 10W	> 0.7	QFN-12	Tape & Reel ¹
iW3989-20	above 10W	> 0.9	QFN-12	Tape & Reel ¹
iW3989-30	above 10W	> 0.7	QFN-12	Tape & Reel ¹

Note 1: Tape & Reel packing quantity is 1,500/reel. Minimum packing quantity is 1,500.

Digital AC Direct Power Controller for Phase-Cut Dimmable LED Luminaires

Disclaimer

Unless otherwise agreed in writing, the Dialog Semiconductor products (and any associated software) referred to in this document are not designed, authorized or warranted to be suitable for use in life support, life-critical or safety-critical systems or equipment, nor in applications where failure or malfunction of a Dialog Semiconductor product (or associated software) can reasonably be expected to result in personal injury, death or severe property or environmental damage. Dialog Semiconductor and its suppliers accept no liability for inclusion and/or use of Dialog Semiconductor products (and any associated software) in such equipment or applications and therefore such inclusion and/or use is at the customer's own risk.

Information in this document is believed to be accurate and reliable. However, Dialog Semiconductor does not give any representations or warranties, express or implied, as to the accuracy or completeness of such information. Dialog Semiconductor furthermore takes no responsibility whatsoever for the content in this document if provided by any information source outside of Dialog Semiconductor.

Dialog Semiconductor reserves the right to change without notice the information published in this document, including, without limitation, the specification and the design of the related semiconductor products, software and applications. Notwithstanding the foregoing, for any automotive grade version of the device, Dialog Semiconductor reserves the right to change the information published in this document, including, without limitation, the specification and the design of the related semiconductor products, software and applications, in accordance with its standard automotive change notification process.

Applications, software, and semiconductor products described in this document are for illustrative purposes only. Dialog Semiconductor makes no representation or warranty that such applications, software and semiconductor products will be suitable for the specified use without further testing or modification. Unless otherwise agreed in writing, such testing or modification is the sole responsibility of the customer and Dialog Semiconductor excludes all liability in this respect.

Nothing in this document may be construed as a license for customer to use the Dialog Semiconductor products, software and applications referred to in this document. Such license must be separately sought by customer with Dialog Semiconductor.

All use of Dialog Semiconductor products, software and applications referred to in this document is subject to Dialog Semiconductor's [Standard Terms and Conditions of Sale](#), available on the company website (www.dialog-semiconductor.com) unless otherwise stated.

Dialog, Dialog Semiconductor and the Dialog logo are trademarks of Dialog Semiconductor Plc or its subsidiaries. All other product or service names and marks are the property of their respective owners.

Qualcomm is a trademark of Qualcomm Incorporated, registered in the United States and other countries. Quick Charge is a trademark of Qualcomm Incorporated. All Qualcomm Incorporated trademarks are used with permission.

© 2020 Dialog Semiconductor. All rights reserved.

RoHS Compliance

Dialog Semiconductor's suppliers certify that its products are in compliance with the requirements of Directive 2011/65/EU of the European Parliament on the restriction of the use of certain hazardous substances in electrical and electronic equipment. RoHS certificates from our suppliers are available on request.

Contacting Dialog Semiconductor

United Kingdom (Headquarters)
Dialog Semiconductor (UK) LTD
Phone: +44 1793 757700

Germany
Dialog Semiconductor GmbH
Phone: +49 7021 805-0

The Netherlands
Dialog Semiconductor B.V.
Phone: +31 73 640 8822

Email
info_pcbg@diasemi.com

North America
Dialog Semiconductor Inc.
Phone: +1 408 845 8500

Japan
Dialog Semiconductor K. K.
Phone: +81 3 5769 5100

Taiwan
Dialog Semiconductor Taiwan
Phone: +886 281 786 222

Web site:
www.dialog-semiconductor.com

Hong Kong
Dialog Semiconductor Hong Kong
Phone: +852 2607 4271

Korea
Dialog Semiconductor Korea
Phone: +82 2 3469 8200

China (Shenzhen)
Dialog Semiconductor China
Phone: +86 755 2981 3669

China (Shanghai)
Dialog Semiconductor China
Phone: +86 21 5424 9058

X-ON Electronics

Largest Supplier of Electrical and Electronic Components

Click to view similar products for [LED Lighting Drivers](#) category:

Click to view products by [Dialog Semiconductor](#) manufacturer:

Other Similar products are found below :

[LV5235V-MPB-H](#) [MB39C602PNF-G-JNEFE1](#) [MIC2871YMK-T5](#) [AL1676-10BS7-13](#) [AL1676-20AS7-13](#) [AP5726WUG-7](#) [ICL8201](#)
[IS31BL3228B-UTLS2-TR](#) [IS31BL3506B-TTLS2-TR](#) [AL3157F-7](#) [AP5725FDCG-7](#) [LV52204MTTBG](#) [AP5725WUG-7](#) [STP4CMPQTR](#)
[NCL30086BDR2G](#) [CAT4004BHU2-GT3](#) [LV52207AXA-VH](#) [AP1694AS-13](#) [TLE4242EJ](#) [AS3688](#) [IS31LT3172-GRLS4-TR](#) [TLD2311EL](#)
[KTD2694EDQ-TR](#) [KTZ8864EJAA-TR](#) [IS32LT3174-GRLA3-TR](#) [MP2488DN-LF-Z](#) [NLM0010XTSA1](#) [AL1676-20BS7-13](#)
[ZXLD1370QESTTC](#) [MPQ7220GF-AEC1-P](#) [MPQ7220GR-AEC1-P](#) [MPQ4425BGJ-AEC1-P](#) [MPQ7220GF-AEC1-Z](#) [MPQ7220GR-AEC1-Z](#)
[MPQ4425BGJ-AEC1-Z](#) [IS31FL3737B-QFLS4-TR](#) [IS31FL3239-QFLS4-TR](#) [KTD2058EUAC-TR](#) [KTD2037EWE-TR](#) [DIO5662ST6](#)
[KTD2026BEWE-TR](#) [MAX20052CATC/V+](#) [MAX25606AUP/V+](#) [BD6586MUV-E2](#) [BD9206EFV-E2](#) [LYT4227E](#) [LYT6079C-TL](#)
[MP3394SGF-P](#) [MP4689AGN-P](#) [MPQ4425AGQB-AEC1-Z](#)