

USB Power Delivery 3.0 Controller with Integrated Current Sense Supports Qualcomm Quick Charge 4+

1 Description

The iW657P is a USB Power Delivery (USB PD) interface controller which handles the communication between a Power Adapter and Mobile Device (MD). The controller enables the mobile device to alter the V_{BUS} voltage from the default 5V and/or maximum current limitation (e.g. 3A) for higher power output or better efficiency. The iW657P supports USB PD 3.0, including Programmable Power Supply (PPS) support, while being backwards compatible with USB PD 2.0. The device also supports Qualcomm® Quick Charge™ 4+ technology. The iW657P enables the use of advanced USB Type-C™ connector technology with CC1/CC2 pins for MD attach/detach detection and V_{CONN} support for Electronically Marked Cable (EMC) rated current reading. The iW657P also integrates a high current charge-pump circuit to drive an external NFET V_{BUS} disconnect switch.

The iW657P resides on the secondary side of an AC/DC power supply and negotiates voltage and current settings with the primary-side controller, depending on the requests from the MD. The iW657P uses Dialog's proprietary secondary-to-primary digital communication technology and when paired with one of Dialog's primary-side **RapidCharge™** controllers, such as the iW1781, iW1791 or iW1799, the iW657P eliminates the need for a discrete decoder on the primary side by using one optocoupler to transmit all necessary information for rapid charging to the primary side. This includes output voltage requests, output current limits, output voltage undershoot, output over-voltage, and fault and reset signals. The iW657P incorporates Dialog's proven and reliable DLNK technology to communicate from the secondary to the primary and also has a built-in optocoupler LED driver to minimize the bill of material cost.

The power supply designed with the iW657P is fully protected. Using over-voltage protection on the D+/D-/CC1/CC2 pins, the iW657P helps to address soft short issues in cables and connectors caused by poor or loose connections between the cable connector and the socket, contamination in the USB connector, or a worn out cable. Additionally, proprietary short circuit protection on the V_{BUS} NFET ensures safe operation in the event of a short on the output, while the SD pin can be used with an external NTC resistor for protection from over-temperature faults. The iW657P also integrates a secondary-side current sensing circuit that provides additional over-current protection for the power adapter.

2 Features

- USB-IF PD certified: USB PD 3.0 + Programmable Power Supply (PPS)
 - » Maximum power limit in PPS to minimize power adapter size
 - » Integrated CC transmitter/receiver supports BMC communication
 - » Backwards-compatible with USB PD 2.0
- Supports Qualcomm Quick Charge 4+ Technology
- Supports up to 7 Power Data Objects (PDOs)
- Supports wide output voltage range from 3.3 to 21V
- Compatible with USB Type-C specification Rev 1.2 for MD attach/detach detection and V_{CONN} support for smart cables
- Integrated charge pump supports single NFET V_{BUS} switch
- 9-bit ADC provides accurate current (optional) and voltage sensing
- Proprietary V_{BUS} NFET protection to protect V_{BUS} switch from damage due to an output short circuit
- Proprietary secondary-to-primary digital communication eliminates discrete decoders on the primary side and simplifies system designs
- D+/D-/CC1/CC2 over-voltage protection (OVP) address soft short issues in the output cables and connectors
- Optional secondary-side current sensing circuit provides additional protection for over-load fault
- Uses external NTC for power adapter temperature sensing
- Programmable active fast discharge from a high voltage V_{BUS} level to 5V at MD unplug or upon request with built-in switch or external switch
- Intelligent circuits helps achieve < 20mW system no-load power at 5V steady-state operation.
- 14-pin 4x3mm TDFN package

3 Applications

- Rapid-charging AC/DC adapters for smart phones, tablets and other portable devices



Qualcomm® Quick Charge™ is a product of Qualcomm Technologies, Inc.

USB Power Delivery 3.0 Controller with Integrated Current Sense Supports Qualcomm Quick Charge 4+

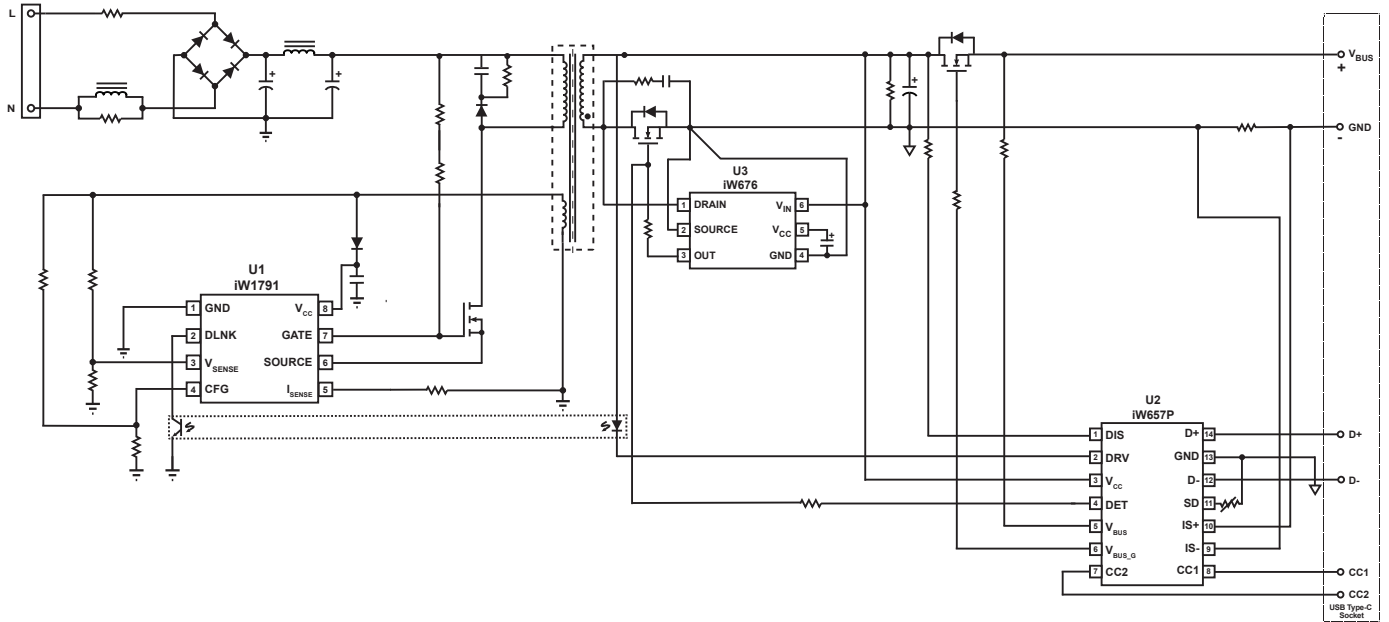

Figure 3.1 : iW657P Typical Application Circuit with Secondary-Side Current Sensing (with iW1791 as the Primary-Side Controller and the iW676 as the Synchronous Rectifier Controller)

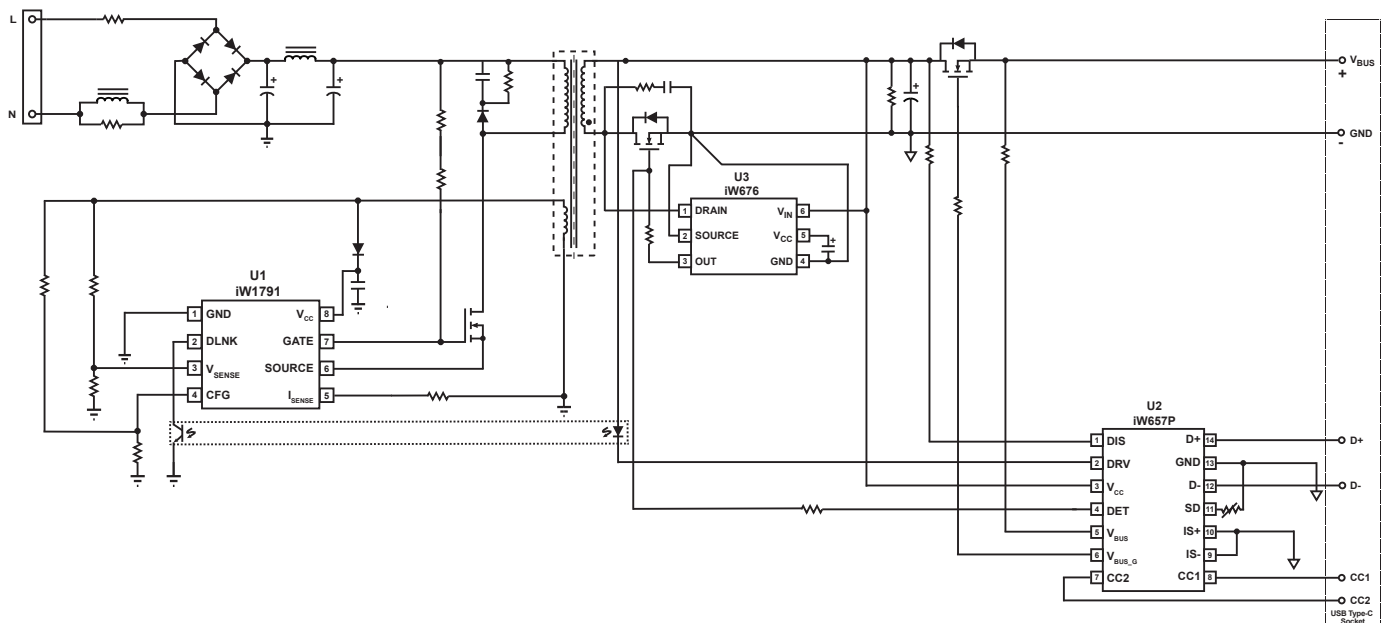

Figure 3.2 : iW657P Typical Application Circuit without Secondary-Side Current Sensing (with iW1791 as the Primary-Side Controller and the iW676 as the Synchronous Rectifier Controller)

USB Power Delivery 3.0 Controller with Integrated Current Sense
Supports Qualcomm Quick Charge 4+

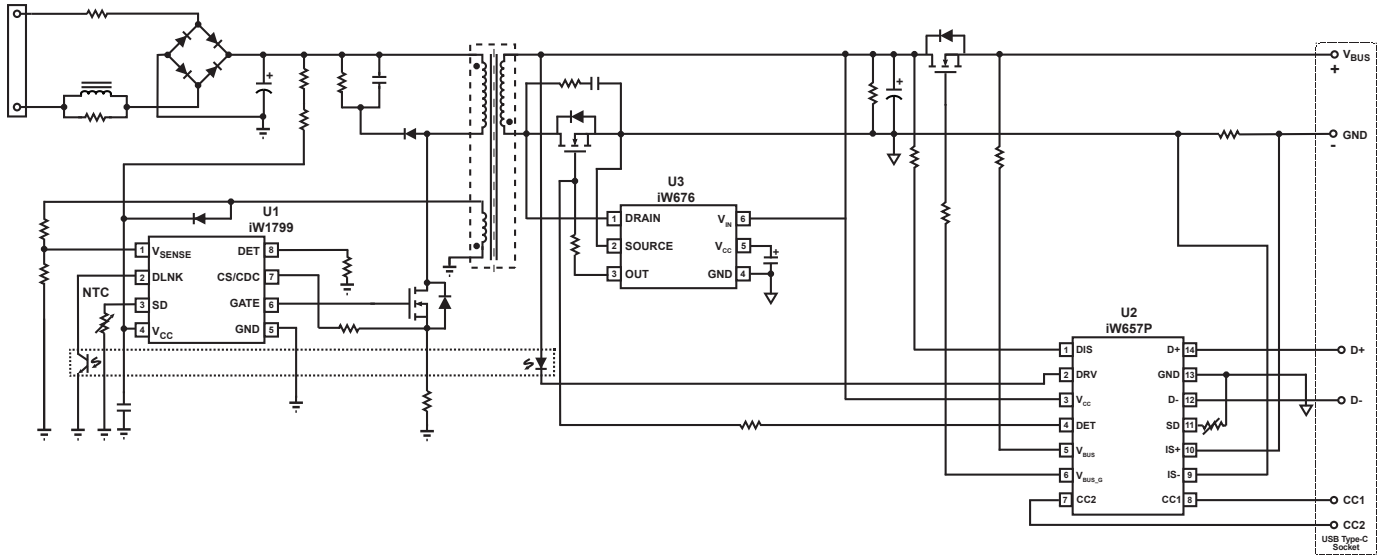
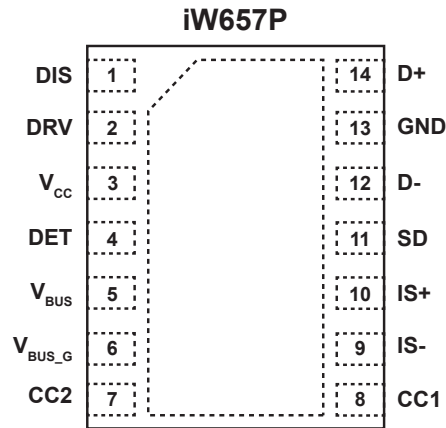

Figure 3.3 : iW657P Typical Application Circuit with Secondary-Side Current Sensing
(with iW1799 as the Primary-Side Controller and the iW676 as the Synchronous Rectifier Controller)

USB Power Delivery 3.0 Controller with Integrated Current Sense Supports Qualcomm Quick Charge 4+

4 Pinout Description



**Figure 4.1 : 14-Lead TDFN 4x3mm Package
(Top View, Transparent)**

Pin Number DFN-14	Pin Name	Type	Pin Description
1	DIS	Analog Output	Discharging circuit. Used for fast discharging of output capacitor.
2	DRV	Analog Output	External circuit drive. Can be used to drive optocoupler LED with automatic current limiting for transmitting signals to primary side.
3	V _{CC}	Power Supply	IC power supply.
4	DET	Analog Input	AC unplug detect.
5	V _{BUS}	Analog Input/ Output	Monitor V _{BUS} voltage after N-FET switch.
6	V _{BUS_G}	Analog Input/ Output	Connect to external N-FET gate pin for gate-source voltage control.
7	CC2	Analog Input/ Output	Configuration Channel 2.
8	CC1	Analog Input/ Output	Configuration Channel 1.
9	IS-	Analog Input	Output current sensing terminal - (for current sensing resistor).
10	IS+	Analog Input	Output current sensing terminal + (for current sensing resistor).
11	SD	Analog Input/ Output	Connect to an external NTC resistor to measure the power adapter temperature.
12	D-	Analog Input/ Output	USB D- signal.
13	GND	Ground	Ground.
14	D+	Analog Input/ Output	USB D+ signal.

USB Power Delivery 3.0 Controller with Integrated Current Sense Supports Qualcomm Quick Charge 4+

5 Absolute Maximum Ratings

Absolute maximum ratings are the parameter values or ranges which can cause permanent damage if exceeded.

Parameter	Symbol	Value	Units
V _{CC} voltage	V _{CC}	-0.3 to 30	V
DIS voltage	V _{DIS}	-0.3 to 30	V
DRV voltage	V _{DRV}	-0.3 to 30	V
V _{SD} voltage	V _{SD}	-0.3 to 7	V
D- voltage	V _{D-}	-0.3 to 7	V
D+ voltage	V _{D+}	-0.3 to 7	V
CC1 voltage	V _{CC1}	-0.3 to 30	V
CC2 voltage	V _{CC2}	-0.3 to 30	V
V _{BUS} voltage (I _{VBUS} < 10mA)	V _{BUS}	-0.7 to 30	V
V _{BUS_G} voltage	V _{BUS_G}	-0.7 to 35	V
DET voltage	V _{DET}	-0.7 to 30	V
Peak current at DIS pin (V _{DIS} = 12V)	I _{DIS}	600	mA
IS+ voltage	V _{IS+}	-0.3 to 7	V
IS- voltage	V _{IS-}	-0.3 to 7	V
Maximum junction temperature	T _{JMAX}	150	°C
Operating junction temperature	T _{JOPT}	-40 to 150	°C
Storage temperature	T _{STG}	-65 to 150	°C
ESD rating per JEDEC JESD22-A114 (D+, D-, CC1, CC2)		±8,000	V
ESD rating per JEDEC JESD22-A114 (all other pins)		±2,000	V

Notes:

Note 1. Stresses beyond those listed under Absolute Maximum Ratings may cause permanent damage to the device. These are stress ratings only, so functional operation of the device at these or any other conditions beyond those indicated in the operational sections of the specification are not implied. Exposure to absolute maximum rating conditions for extended periods may affect device reliability.

iW657P

USB Power Delivery 3.0 Controller with Integrated Current Sense Supports Qualcomm Quick Charge 4+

6 Physical Dimensions

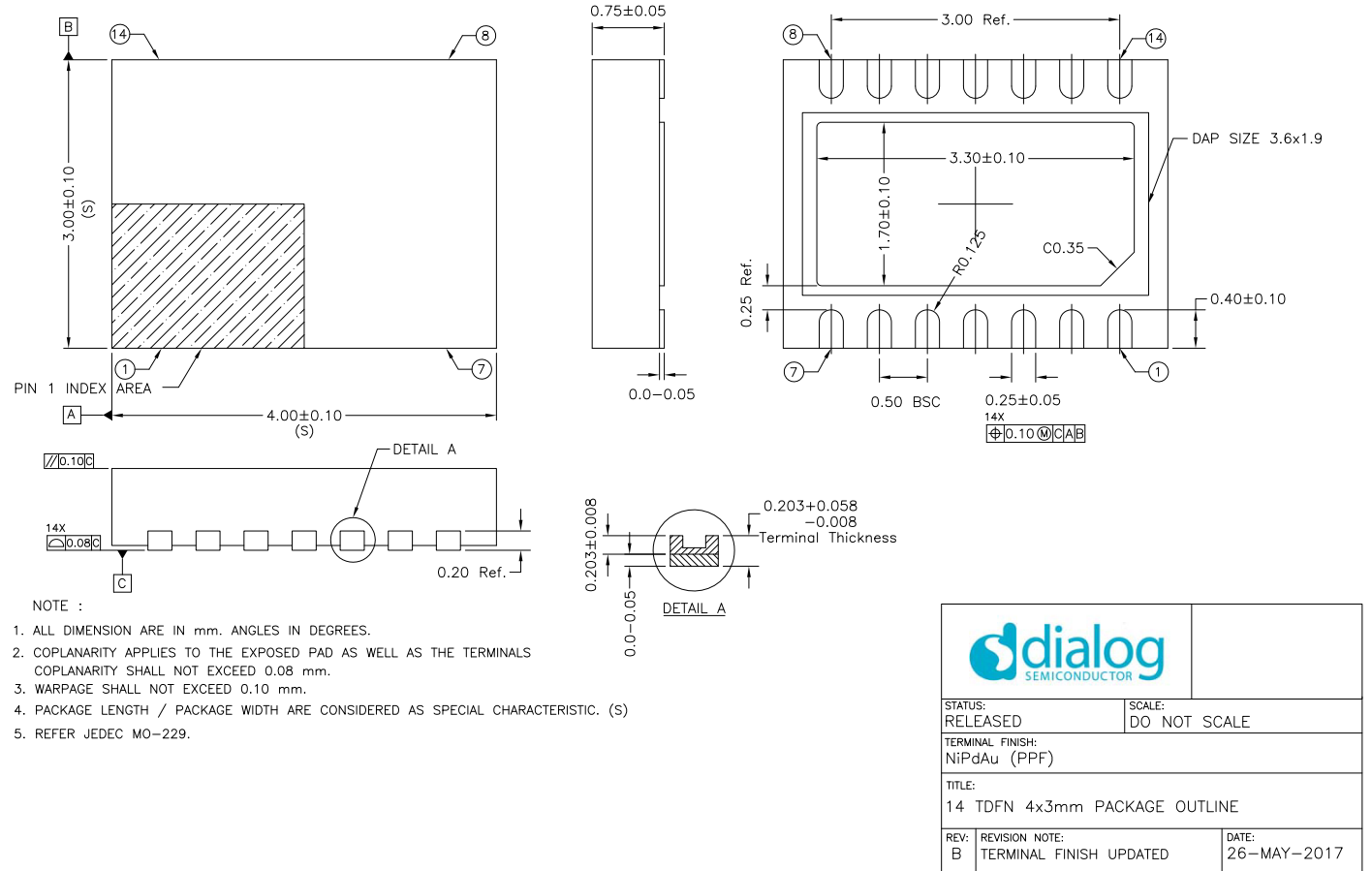
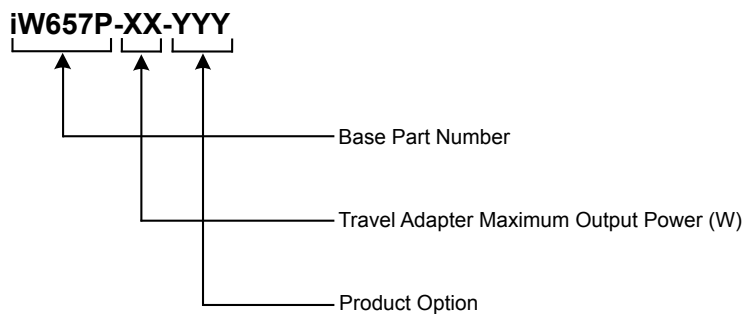

Figure 6.1 : 14-Lead TDFN 4x3mm Package

7 Part Number Code Description



USB Power Delivery 3.0 Controller with Integrated Current Sense Supports Qualcomm Quick Charge 4+

Disclaimer

Information in this document is believed to be accurate and reliable. However, Dialog Semiconductor does not give any representations or warranties, expressed or implied, as to the accuracy or completeness of such information. Dialog Semiconductor furthermore takes no responsibility whatsoever for the content in this document if provided by any information source outside of Dialog Semiconductor.

Dialog Semiconductor reserves the right to change without notice the information published in this document, including without limitation the specification and the design of the related semiconductor products, software and applications.

Applications, software, and semiconductor products described in this document are for illustrative purposes only. Dialog Semiconductor makes no representation or warranty that such applications, software and semiconductor products will be suitable for the specified use without further testing or modification. Unless otherwise agreed in writing, such testing or modification is the sole responsibility of the customer and Dialog Semiconductor excludes all liability in this respect.

Customer notes that nothing in this document may be construed as a license for customer to use the Dialog Semiconductor products, software and applications referred to in this document. Such license must be separately sought by customer with Dialog Semiconductor.

All use of Dialog Semiconductor products, software and applications referred to in this document are subject to [Dialog Semiconductor's Standard Terms and Conditions of Sale](#), available on the company website (www.dialog-semiconductor.com) unless otherwise stated.

Dialog and the Dialog logo are trademarks of Dialog Semiconductor plc or its subsidiaries. All other product or service names are the property of their respective owners.

Qualcomm is a trademark of Qualcomm Incorporated, registered in the United States and other countries. Quick Charge is a trademark of Qualcomm Incorporated. All Qualcomm Incorporated trademarks are used with permission.

© 2018 Dialog Semiconductor. All rights reserved.

RoHS Compliance

Dialog Semiconductor's suppliers certify that its products are in compliance with the requirements of Directive 2011/65/EU of the European Parliament on the restriction of the use of certain hazardous substances in electrical and electronic equipment. RoHS certificates from our suppliers are available on request.

Contacting Dialog Semiconductor

United Kingdom (Headquarters)
Dialog Semiconductor (UK) LTD
Phone: +44 1793 757700

Germany
Dialog Semiconductor GmbH
Phone: +49 7021 805-0

The Netherlands
Dialog Semiconductor B.V.
Phone: +31 73 640 8822

Email
info_pcbg@diasemi.com

North America
Dialog Semiconductor Inc.
Phone: +1 408 845 8500

Japan
Dialog Semiconductor K. K.
Phone: +81 3 5769 5100

Taiwan
Dialog Semiconductor Taiwan
Phone: +886 281 786 222

Web site:
www.dialog-semiconductor.com

Hong Kong
Dialog Semiconductor Hong Kong
Phone: +852 2607 4271

Korea
Dialog Semiconductor Korea
Phone: +82 2 3469 8200

China (Shenzhen)
Dialog Semiconductor China
Phone: +86 755 2981 3669

China (Shanghai)
Dialog Semiconductor China
Phone: +86 21 5424 9058

X-ON Electronics

Largest Supplier of Electrical and Electronic Components

Click to view similar products for [Power Management Specialised - PMIC category:](#)

Click to view products by [Dialog Semiconductor manufacturer:](#)

Other Similar products are found below :

[P9145-I0NQGI](#) [SLG7NT4192VTR](#) [AS3729B-BWLM](#) [LNBH25SPQR](#) [ADP5080ACBZ-1-RL](#) [MC32PF3000A6EP](#) [MB39C831QN-G-EFE2](#)
[MAX9959DCCQ+D](#) [MAX1932ETC+T](#) [MAX1856EUB+T](#) [STNRG011TR](#) [IRPS5401MXI03TRP](#) [S6AE102A0DGN1B200](#)
[MMPF0100FDAEP](#) [MCZ33903DS5EK](#) [S6AE101A0DGNAB200](#) [MCZ33903DS3EK](#) [NCP6924CFCHT1G](#) [MAX17117ETJ+](#) [L9916](#) [L9915-](#)
[CB](#) [MCZ33904D5EK](#) [MCZ33905DS3EK](#) [MMPF0100FCANES](#) [MCZ33905DD3EK](#) [MMPF0100FBANES](#) [WM8325GEFL/V](#)
[MCZ33903DP5EK](#) [MCZ33905DS5EK](#) [MCZ33903D3EK](#) [MCZ33903DD5EK](#) [ADN8835ACPZ-R7](#) [MCZ33903DP5EKR2](#) [MCZ33903D5EK](#)
[MCZ33903DD3EK](#) [MMPF0100FAAZES](#) [SLG7NT4198V](#) [MIC5164YMM](#) [P9180-00NHGI](#) [NCP6914AFCAT1G](#) [TLE9261QX](#)
[TEA1998TS/1H](#) [MAX881REUB+T](#) [TLE9262QX](#) [TLE8880TN](#) [MAX8520ETP+T](#) [SLG7NT4083V](#) [ADP1031ACPZ-1-R7](#) [ADP1031ACPZ-2-](#)
[R7](#) [ADP1031ACPZ-3-R7](#)