

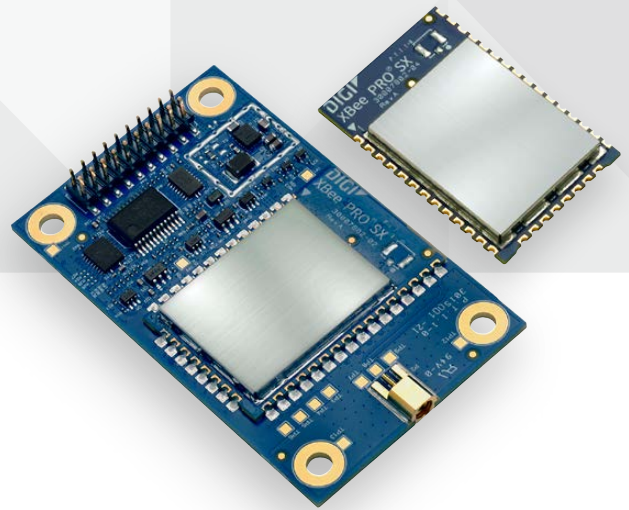

1 WATT/900 MHZ
OEM RF MODULES



XTEND[®] OEM RF MODULES

Long-range wireless modules enable communication from UART serial data with peer-to-peer, point-to-multipoint, repeater and DigiMesh[®] networking topologies

The XTend OEM RF module provides unprecedented range in a low-cost wireless data solution. The module is easy to use, requires minimal power, provides reliable delivery of critical data between devices and is now available in the even smaller Digi XBee[®] Surface Mount form factor to save valuable PCB space.

The XTend module utilizes FHSS (Frequency Hopping Spread Spectrum) agility to avoid interference by hopping to a new frequency on every packet transmission or re-transmission. Its transmit power is software adjustable from 100 mW to 1 W—the maximum output power allowable by governments

that use 900 MHz as a license-free band. The XTend module is approved for use in the United States, Canada, Australia and other countries (contact Digi for a complete listing).

Innovations stamped in its design enable the XTend module to supply two- to eight-times the range of other modules operating within the unlicensed 900 MHz frequency band. The range gained by OEMs and integrators is due to proprietary technologies embedded into each module, including superior RX (receiver) sensitivity, interference immunity, modulation/demodulation techniques and others.

BENEFITS

- Indoor/urban range up to 1000 feet*
- Outdoor line-of-sight range up to 40 miles* (with high gain antenna)
- Outstanding receiver sensitivity (-110 dBm @ 9600 bps)
- Peer-to-peer, point-to-multipoint, repeater and DigiMesh networking topologies
- Adjustable power output from 100 mW to 1 W; up to 4 W EIRP (with 6 dBi antenna)
- Available in the XTend and Digi XBee SMT form factors

APPLICATION EXAMPLE

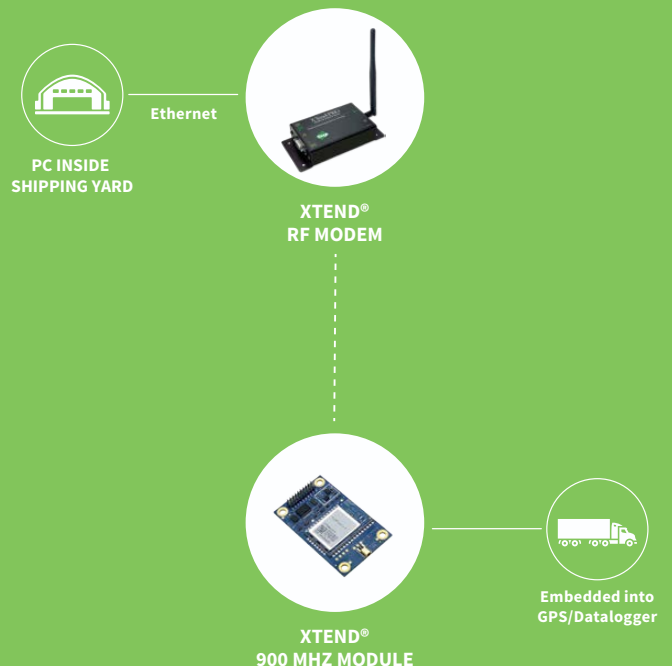

RELATED PRODUCTS



SPECIFICATIONS

XTend® VB Module

Digi XBee®-PRO XTC Module

Digi XBee® XTC Module

PERFORMANCE

FREQUENCY RANGE	ISM 902 – 928 MHz		
INDOOR/URBAN RANGE *	Up to 1000 feet (305 m) with 2.1 dB dipole antenna	Up to 360 ft (110 m)	
OUTDOOR RF LINE-OF-SIGHT RANGE*	Up to 40 miles (64 km) with high gain antenna; Up to 14 miles (22 km) with 2.1 dB dipole antenna	Up to 5 miles with high gain antenna	
TRANSMIT POWER (SOFTWARE SELECTABLE)	100 mW - 1 W (20 - 30 dBm)	Up to 13 dBm	
INTERFACE DATA RATE	1,200 - 230,400 bps (including non-standard baud rates)		
RECEIVER SENSITIVITY (1% PER)	-110 dBm (@9,600 bps throughput data rate), -100 dBm (@115,200 bps)		
RF DATA RATE	10 kbps to 125 kbps		
HARDWARE INTERFACE	20 pin 2 mm pitch header	37 castellated SMT pads	
SIZE	3.7 cm x 6.1 cm x 4.8 cm	3.38 cm x 2.21 cm x 1.29 cm	
ANTENNA OPTIONS	MMCX, RPSMA	RF Pad, U.FL	

NETWORKING AND SECURITY

SPREAD SPECTRUM	FHSS (Frequency Hopping Spread Spectrum)		
MODULATION	FSK (Frequency Shift Keying)		
SUPPORTED NETWORK TOPOLOGIES	Point-to-Point, Point-to-Multipoint, Repeater, Mesh		
CHANNEL CAPACITY	10 hop sequences share 50 frequencies		
ENCRYPTION	256-bit / 128-bit AES		

POWER REQUIREMENTS

SUPPLY VOLTAGE	2.8 - 5.5 VDC	2.6 - 3.6 VDC	2.4 - 3.6 VDC
RX CURRENT	35 mA @ 5V	40 mA @ 3.3V	
TRANSMIT CURRENT	Up to 710 mA @ 30 dBm	Up to 900 mA @ 30 dBm	Up to 55 mA @ 13 dBm
SHUTDOWN MODE POWER DOWN	1 µA typical		
PIN SLEEP POWER DOWN	< 147 µA	2.5 uA	
CYCLIC SLEEP (IDLE CURRENT)	0.3 – 0.8 mA (16 sec cyclic sleep)		

ENVIRONMENTAL

OPERATING TEMPERATURE	-40° C to 85° C (Industrial)		
------------------------------	------------------------------	--	--

CERTIFICATIONS

FCC ID (U.S. CERTIFICATION PART 15.247)	MCQ-XBPSX	MCQ-XBPSX	MCQ-XBSX
IC ID (CANADA)	1846A-XBPSX	1846A-XBPSX	1846A-XBSX
C-TICK (AUSTRALIA)	RCM		

LINE ART

DIGI XBEE/DIGI XBEE-PRO XTC MODULE

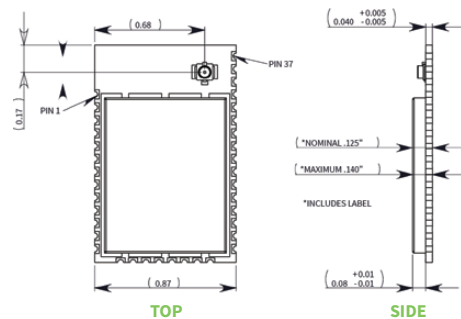

XTEND VB MODULE

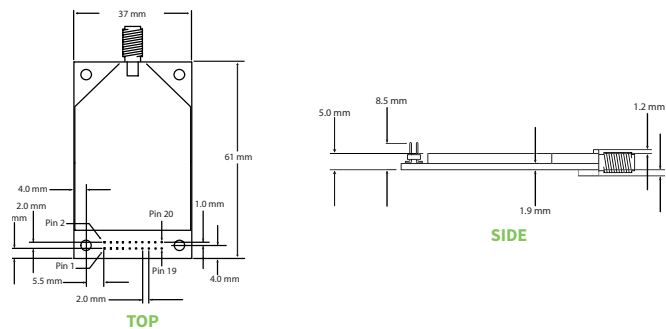

*Range figure estimates are based on free-air terrain with limited sources of interference. Actual range will vary based on transmitting power, orientation of transmitter and receiver, height of transmitting antenna, height of receiving antenna, weather conditions, interference sources in the area, and terrain between receiver and transmitter, including indoor and outdoor structures such as walls, trees, buildings, hills, and mountains.

PART NUMBERS	DESCRIPTION
XTEND VB MODULES	
XTP9B-DMS-001	9XTend Replacement, DigiMesh, RPSMA, North America
XTP9B-DMM-001	9XTend Replacement, DigiMesh, MMCX, North America
XTP9B-DPS-001	9XTend Replacement, P2MP, RPSMA, North America
XTP9B-DPM-001	9XTend Replacement, P2MP, MMCX, North America
XTP9B-DPS-721	9XTend Replacement, P2MP, RPSMA, 128 AES Australia
XTP9B-DPM-721	9XTend Replacement, P2MP, MMCX, 128 AES Australia
DIGI XBEE/DIGI XBEE-PRO XTC (XTEND COMPATIBLE) MODULES	
XBP9XT-DMRS-001	Digi XBee-PRO XTC, 1W, DigiMesh, SMT, RF Pad, North America
XBP9XT-DMUS-001	Digi XBee-PRO XTC, 1W, DigiMesh, SMT, U.FL, North America
XBP9XT-DPRS-001	Digi XBee-PRO XTC, 1W, P2MP, SMT, RF Pad, North America
XBP9XT-DPUS-001	Digi XBee-PRO XTC, 1W, P2MP, SMT, U.FL, North America
XB9XT-DMRS-001	Digi XBee XTC, 20 mW, DigiMesh, SMT, RF Pad, North America
XB9XT-DMUS-001	Digi XBee XTC, 20 mW, DigiMesh, SMT, U.FL, North America
XB9XT-DPRS-001	Digi XBee XTC, 20 mW, P2MP, SMT, RF Pad, North America
XB9XT-DPUS-001	Digi XBee XTC, 20 mW, P2MP, SMT, U.FL, North America
XB9XT-DPRS-721	Digi XBee XTC, 20 mW, P2MP, SMT, RF Pad, 128 AES, Australia
XB9XT-DPUS-721	Digi XBee XTC, 20 mW, P2MP, SMT, U.FL, 128 AES, Australia
XBP9XT-DPRS-721	Digi XBee-PRO XTC, 1W, P2MP, SMT, RF Pad, 128 AES, Australia
XBP9XT-DPUS-721	Digi XBee-PRO XTC, 1W, P2MP, SMT, U.FL, 128 AES, Australia

FOR MORE INFORMATION
PLEASE VISIT WWW.DIGI.COM

DIGI SERVICE AND SUPPORT / You can purchase with confidence knowing that Digi is always available to serve you with expert technical support and our industry leading warranty. For detailed information visit www.digi.com/support.

© 1996-2018 Digi International Inc. All rights reserved.
All trademarks are the property of their respective owners.

91001416
E7/1118

DIGI INTERNATIONAL WORLDWIDE HQ
877-912-3444 / 952-912-3444 / www.digi.com

DIGI INTERNATIONAL GERMANY
+49-89-540-428-0

DIGI INTERNATIONAL JAPAN
+81-3-5428-0261 / www.digi-intl.co.jp

DIGI INTERNATIONAL SINGAPORE
+65-6213-5380

DIGI INTERNATIONAL CHINA
+86-21-50492199 / www.digi.com.cn



X-ON Electronics

Largest Supplier of Electrical and Electronic Components

Click to view similar products for [Antennas](#) category:

Click to view products by [Digi International](#) manufacturer:

Other Similar products are found below :

[GAN30084EU](#) [930-033-R](#) [GW17.07.0250E](#) [1513563-1](#) [EXE902SM](#) [APAMPG-117](#) [MAF94383](#) [W3908B0100](#) [W6102B0100](#) [YE572113-30RSMM](#) [108-00014-50](#) [66089-2406](#) [A09-F8NF-M](#) [A09-F5NF-M](#) [RGFRA1903041A1T](#) [W3593B0100](#) [W3921B0100](#) [SIMNA-868](#) [SIMNA-915](#) [SIMNA-433](#) [W1044](#) [W1049B090](#) [WTL2449CQ1-FRSMM](#) [CPL9C](#) [EXB148BN](#) [0600-00060](#) [TRA9020S3PBN-001](#) [GD5W-28P-NF](#) [MA9-7N](#) [GD53-25](#) [GD5W-21P-NF](#) [EXB144SM](#) [C37](#) [MAF94051](#) [GD35-17P-NF](#) [P1744](#) [MA9-5N](#) [EXD420PL](#) [B1322NR](#) [QWFTB120](#) [MAF94271](#) [MAF94300](#) [GPSMB301](#) [FG4403](#) [AO-AGSM-OM54](#) [5200232](#) [MIKROE-2349](#) [WCM.01.0111](#) [MIKROE-2393](#) [MIKROE-2352](#)