

PmodRS232™ Reference Manual

Revised May 24, 2016

This manual applies to the PmodRS232 rev. B

Overview

The Digilent PmodRS232 converts between digital logic voltage levels to RS232 voltage levels. The RS232 module is configured as a data communications equipment (DCE) device. It connects to data terminal equipment (DTE) devices, such as the serial port on a PC, using a straight-through cable.

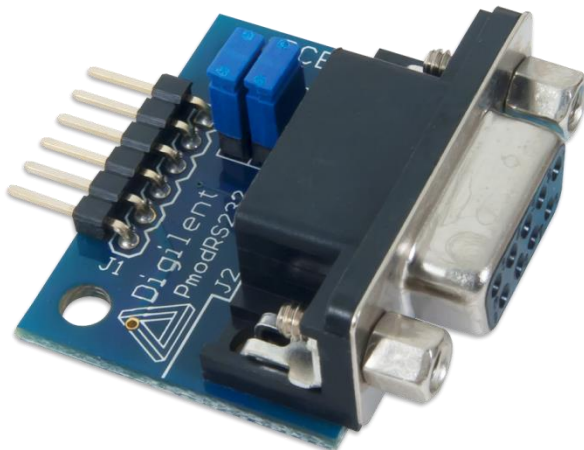

The PmodRS232.

Features include:

- Standard RS232 DB9 connector
- Optional RTS and CTS handshaking functions
- Small PCB size for flexible designs 1.0" × 1.3" (2.5 cm × 3.3 cm)
- 6-pin Pmod connector with UART interface
- Example code available in [resource center](#)

1 Functional Description

The PmodRS232 utilizes the [Maxim Integrated MAX3232 transceiver](#) to allow the system board to communicate with UART compatible devices or other components that use a serial interface.

2 Interfacing with the Pmod

The PmodRS232 communicates with the host board via the UART protocol. The arrangement of the pins is the old UART communication style so that a crossover cable will be required if attaching this Pmod to one of the dedicated UART Pmod headers on a Digilent system board.

A pinout description table and diagram for the PmodRS232 are provided below:

Pin	Signal	Description
1	CTS	Clear to Send
2	RTS	Ready to Send
3	TXD	Transmit Data
4	RXD	Receive Data
5	GND	Power Supply Ground
6	VCC	Power Supply (3.3V/5V)

Table 1. Connector J1 pin descriptions.

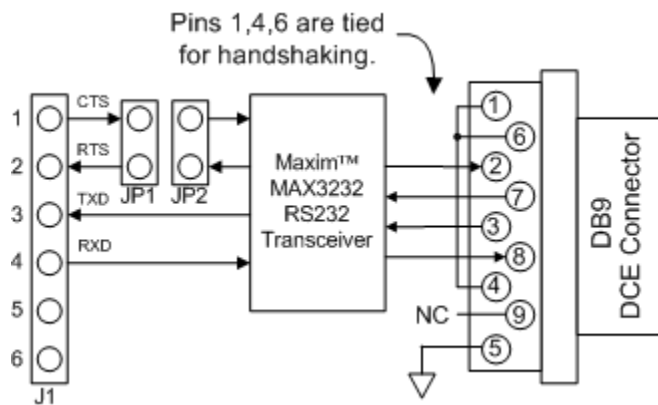

Figure 1. PmodRS232 block diagram.

JP1	JP2	Communication
Unloaded	Pins 1 and 2 are shorted together	3-wire communication
Pin 1 connected to pin 1 of JP2 and pin 2 connected to pin 2 of JP2	Pin 1 connected to pin 1 of JP1 and pin 2 connected to pin 2 of JP2	5-wire communication

Table 2. Jumper block settings.

There are two jumper blocks on the PmodRS232; JP1 and JP2. These jumper blocks allow the PmodRS232 to communicate in either a 3-wire or 5-wire operation. When the jumper block on JP2 is loaded and the block on JP1 is unloaded, the on-board chip has its RTS and CTS lines tied together, indicating to the MAX3232 that it is free to transfer data whenever it receives any and enabling 3-wire communication. JP1 must be unloaded in this configuration to ensure that pins 1 and 2 on the Pmod header are not shorted together which could potentially damage the system board.

5-wire communication requires that pin 1 of JP1 is connected to pin 1 of JP2, and that pin 2 of both JP1 and JP2 are tied together as well, effectively allowing for CTS/RTS handshaking between the Pmod header and the on-board chip. Both the fifth wire in this configuration and the third wire in the 3-wire communication is the ground signal line.

Any external power applied to the PmodRS232 must be within 3V and 5.5V; however, it is recommended that Pmod is operated at 3.3V.

3 Physical Dimensions

The pins on the pin header are spaced 100 mil apart. The PCB is 1 inch long on the sides parallel to the pins on the pin header and 1.3 inches long on the sides perpendicular to the pins on the pin header. The DB9 connector adds an additional 0.25 inches to the length of the PCB that is parallel to pins on the pin header.

X-ON Electronics

Largest Supplier of Electrical and Electronic Components

Click to view similar products for [Interface Development Tools](#) category:

Click to view products by [Digilent](#) manufacturer:

Other Similar products are found below :

[DP130SSEVM](#) [ISO3086TEVM-436](#) [ADP5585CP-EVALZ](#) [CHA2066-99F](#) [AS8650-DB](#) [MLX80104 TESTINTERFACE](#) [I2C-CPEV/NOPB](#)
[ISO35TEVM-434](#) [416100120-3](#) [XR18910ILEVB](#) [XR21B1421IL28-0A-EVB](#) [EVAL-ADM2491EEBZ](#) [MAXREFDES23DB#](#)
[MAX9286COAXEVKIT#](#) [MAX3100EVKIT](#) [MAX13235EEVKIT](#) [MAX14970EVKIT#](#) [XR21B1424IV64-0A-EVB](#) [CMOD232+](#)
[MAX13042EEVKIT+](#) [MAX14838EVKIT#](#) [MAXCAM705OV635AAA#](#) [MAX9205EVKIT](#) [DS100BR111AEVK/NOPB](#) [DC241C](#)
[MAX9286RCARH3DB#](#) [MAX13035EEVKIT+](#) [DC1794A](#) [SN65HVS885EVM](#) [EVB81112-A1](#) [DFR0257](#) [ZLR964122L](#) [ZLR88822L](#)
[DC196A-B](#) [DC196A-A](#) [DC327A](#) [OM13585UL](#) [MAX16972AGEEVKIT#](#) [MARS1-DEMO3-ADAPTER-GEVB](#) [MAX7315EVKIT+](#) [PIM511](#)
[PIM536](#) [PIM517](#) [DEV-17512](#) [STR-FUSB3307MPX-PPS-GEVK](#) [MAXREFDES177#](#) [EVAL-ADM2567EEBZ](#) [EVAL-ADN4654EBZ](#)
[MAX9275COAXEVKIT#](#) [MAX2202XEVKIT#](#)