

Description

The 74LVC1G126Q is an automotive-compliant, single, non-inverting buffer/bus driver with a 3-state output. The output enters a high-impedance state when a LOW level is applied to the output enable (OE) pin. The device is designed for operation with a power supply range of 1.65V to 5.5V. The inputs are tolerant to 5.5V, allowing this device to be used in a mixed-voltage environment. The device is fully specified for partial power down applications using I_{OFF}. The I_{OFF} circuitry disables the output preventing damaging current backflow when the device is powered down.

Features

- Grade 1 Ambient Temperature Operation: -40°C to +125°C
- Wide Supply Voltage Range from 1.65V to 5.5V
- ±24mA Output Drive at 3.3V
- CMOS Low Power Consumption
- I_{OFF} Supports Partial-Power-Down Mode Operation
- Inputs Accept up to 5.5V
- ESD Protection Tested per AEC-Q100
 - Exceeds 2000V Human Body Model (AEC-Q100-002)
 - Exceeds 1000V Charged Device Model (AEC-Q100-011)
- Latch-Up Exceeds 100mA (AEC-Q100-004)
- **Totally Lead-Free & Fully RoHS Compliant (Notes 1 & 2)**
- **Halogen and Antimony Free. "Green" Device (Note 3)**
- **The 74LVC1G126Q is suitable for automotive applications requiring specific change control; this part is AEC-Q100 qualified, PPAP capable, and manufactured in IATF 16949 certified facilities.**

<https://www.diodes.com/quality/product-definitions/>

- Notes:
1. No purposely added lead. Fully EU Directive 2002/95/EC (RoHS), 2011/65/EU (RoHS 2) & 2015/863/EU (RoHS 3) compliant.
 2. See <https://www.diodes.com/quality/lead-free/> for more information about Diodes Incorporated's definitions of Halogen- and Antimony-free, "Green" and Lead-free.
 3. Halogen- and Antimony-free "Green" products are defined as those which contain <900ppm bromine, <900ppm chlorine (<1500ppm total Br + Cl) and <1000ppm antimony compounds.

Pin Assignments

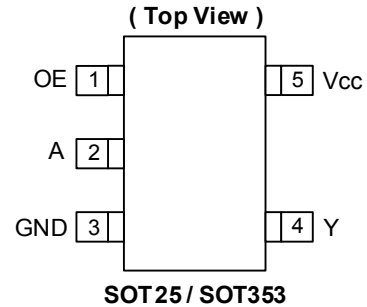

Applications

- Voltage Level Shifting
- General Purpose Logic
- Power Down Signal Isolation
- Wide Array of Products, such as:
 - Automotive Applications within Grade 1 Temperature Range
 - Industrial Computing/Controls/Automation
 - High Reliability Networking/Communications
 - Industrial/Agricultural Equipment

Pin Descriptions

| Pin Name | Description |
|-----------------|---------------------------|
| OE | Output Enable Active HIGH |
| A | Data Input |
| GND | Ground |
| Y | Data Output |
| V _{CC} | Supply Voltage |

Logic Diagram

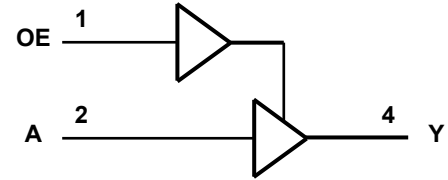

Function Table

| Inputs | | Output |
|--------|---|--------|
| OE | A | Y |
| H | H | H |
| H | L | L |
| L | X | Z |

Absolute Maximum Ratings (Notes 4 & 5)

| Symbol | Description | Rating | Unit |
|-----------------------------------|---|------------------------------|------|
| ESD HBM | Human Body Model ESD Protection | 2 | kV |
| ESD CDM | Charged Device Model ESD Protection | 1 | kV |
| V _{CC} | Supply Voltage Range | -0.5 to 6.5 | V |
| V _I | Input Voltage Range | -0.5 to 6.5 | V |
| V _O | Voltage Applied to Output in High Impedance or I _{OFF} State | -0.5 to 6.5 | V |
| V _O | Voltage Applied to Output in High or Low State | -0.5 to V _{CC} +0.5 | V |
| I _{IK} | Input Clamp Current V _I < 0 | -50 | mA |
| I _{OK} | Output Clamp Current | -50 | mA |
| I _O | Continuous Output Current | ±50 | mA |
| I _{CC} , I _{GN} | Continuous Current Through V _{CC} or GND | ±100 | mA |
| T _J | Operating Junction Temperature | -40 to +150 | °C |
| T _{STG} | Storage Temperature | -65 to +150 | °C |

- Notes:
- Stresses beyond the absolute maximum can result in immediate failure or reduced reliability. These are stress values and device operation should be within recommend values.
 - Forcing the maximum allowed voltage could cause a condition exceeding the maximum current or conversely forcing the maximum current could cause a condition exceeding the maximum voltage. The ratings of both current and voltage must be maintained within the controlled range.

Recommended Operating Conditions (Note 6)

| Symbol | Parameter | Min | Max | Unit | |
|-----------------|------------------------------------|---|------------------------|------------------------|------|
| V _{CC} | Operating Voltage | Operating | 1.65 | 5.5 | V |
| | | Data Retention Only | 1.5 | — | V |
| V _{IH} | High-Level Input Voltage | V _{CC} = 1.65V to 1.95V | 0.65 × V _{CC} | — | V |
| | | V _{CC} = 2.3V to 2.7V | 1.7 | — | |
| | | V _{CC} = 3V to 3.6V | 2 | — | |
| | | V _{CC} = 4.5V to 5.5V | 0.7 × V _{CC} | — | |
| V _{IL} | Low-Level Input Voltage | V _{CC} = 1.65V to 1.95V | — | 0.35 × V _{CC} | V |
| | | V _{CC} = 2.3V to 2.7V | — | 0.7 | |
| | | V _{CC} = 3V to 3.6V | — | 0.8 | |
| | | V _{CC} = 4.5V to 5.5V | — | 0.3 × V _{CC} | |
| V _I | Input Voltage | 0 | 5.5 | V | |
| V _O | Output Voltage | 0 | V _{CC} | V | |
| I _{OH} | High-Level Output Current | V _{CC} = 1.65V | — | -4 | mA |
| | | V _{CC} = 2.3V | — | -8 | |
| | | V _{CC} = 2.7V | — | -12 | |
| | | V _{CC} = 3V | — | -16 | |
| | | V _{CC} = 4.5V | — | -24 | |
| I _{OL} | Low-Level Output Current | V _{CC} = 1.65V | — | 4 | mA |
| | | V _{CC} = 2.3V | — | 8 | |
| | | V _{CC} = 2.7V | — | 12 | |
| | | V _{CC} = 3V | — | 16 | |
| | | V _{CC} = 4.5V | — | 24 | |
| Δt/ΔV | Input Transition Rise or Fall Rate | V _{CC} = 1.8V ± 0.15V, 2.5V ± 0.2V | — | 20 | ns/V |
| | | V _{CC} = 3.3V ± 0.3V | — | 10 | |
| | | V _{CC} = 5V ± 0.5V | — | 5 | |
| T _A | Operating Free-Air Temperature | — | -40 | +125 | °C |

Note: 6. Unused inputs should be held at V_{CC} or Ground.

Electrical Characteristics (All typical values are at $V_{CC} = 3.3V$, $T_A = +25^\circ C$)

| Symbol | Parameter | Test Conditions | V _{CC} | -40°C to +125°C | | | Unit | |
|------------------|----------------------------|---|--------------------------|-----------------|-----------------------|-----|------|---|
| | | | | Min | Typ | Max | | |
| V _{OH} | High Level Output Voltage | V _I = V _{IH} or V _{IL} | I _{OH} = -100µA | 1.65V to 5.5V | V _{CC} - 0.1 | — | — | V |
| | | | I _{OH} = -4mA | 1.65V | 0.95 | — | — | |
| | | | I _{OH} = -8mA | 2.3V | 1.7 | — | — | |
| | | | I _{OH} = -12mA | 2.7V | 1.9 | — | — | |
| | | | I _{OH} = -24mA | 3V | 2.0 | — | — | |
| | | | I _{OH} = -32mA | 4.5V | 3.4 | — | — | |
| V _{OL} | Low Level Output Voltage | V _I = V _{IH} or V _{IL} | I _{OL} = 100µA | 1.65V to 5.5V | — | — | 0.10 | V |
| | | | I _{OL} = 4mA | 1.65V | — | — | 0.70 | |
| | | | I _{OL} = 8mA | 2.3V | — | — | 0.45 | |
| | | | I _{OL} = 12mA | 2.7V | — | — | 0.60 | |
| | | | I _{OL} = 24mA | 3V | — | — | 0.80 | |
| | | | I _{OL} = 32mA | 4.5V | — | — | 0.80 | |
| I _I | Input Current | V _I = 5.5V or GND | 0 to 5.5V | — | ±0.1 | ±1 | µA | |
| I _{OFF} | Power Down Leakage Current | V _I or V _O = 5.5V | 0V | — | — | ±2 | µA | |
| I _{OZ} | Z-State Leakage Current | V _O = Ground to 5.5V | 3.6V | — | — | ±2 | µA | |
| I _{CC} | Supply Current | V _I = 5.5V or GND I _O = 0 | 5.5V | — | 0.1 | 4 | µA | |
| ΔI _{CC} | Additional Supply Current | One input at V _{CC} - 0.6V Other inputs at V _{CC} or GND | 3V to 5.5V | — | — | 500 | µA | |
| C _I | Input Capacitance | V _I = GND to V _{CC} | 3.3V | — | 5.0 | — | pF | |

Package Characteristics

| Symbol | Parameter | Package | Test Conditions | Min | Typ | Max | Unit |
|-----------------|---|---------|-----------------|-----|-----|-----|------|
| θ _{JA} | Thermal Resistance Junction-to-Ambient | SOT25 | Note 7 | — | 184 | — | °C/W |
| | | SOT353 | | — | 385 | — | |
| θ _{JC} | Thermal Resistance Junction-to-Case | SOT25 | Note 7 | — | 62 | — | °C/W |
| | | SOT353 | | — | 164 | — | |

Note: 7. Device mounted on FR-4 substrate PC board, 2oz copper, with minimum recommended pad layout.

Switching Characteristics

 Figure 1 Typical Values at $T_A = +25^\circ\text{C}$ and nominal voltages 1.8V, 2.5V, 2.7V, 3.3V, and 5.0V.

| Parameter | From Input | To Output | V_{CC} | $T_A = -40^\circ\text{C to } +125^\circ\text{C}$ | | | Unit |
|-----------|------------|-----------|--------------------------------|--|-----|------|------|
| | | | | Min | Typ | Max | |
| t_{PD} | A | Y | $1.8\text{V} \pm 0.15\text{V}$ | 1.0 | 3.0 | 10.5 | ns |
| | | | $2.5\text{V} \pm 0.2\text{V}$ | 0.5 | 2.1 | 7.0 | |
| | | | 2.7V | 0.5 | 2.3 | 7.0 | |
| | | | $3.3\text{V} \pm 0.3\text{V}$ | 0.5 | 2.0 | 6.0 | |
| | | | $5.0\text{V} \pm 0.5\text{V}$ | 0.5 | 1.7 | 5.5 | |
| t_{EN} | OE | Y | $1.8\text{V} \pm 0.15\text{V}$ | 1.0 | 3.2 | 12.0 | ns |
| | | | $2.5\text{V} \pm 0.2\text{V}$ | 0.5 | 2.2 | 8.5 | |
| | | | 2.7V | 0.5 | 2.4 | 8.5 | |
| | | | $3.3\text{V} \pm 0.3\text{V}$ | 0.5 | 2.1 | 7.0 | |
| | | | $5.0\text{V} \pm 0.5\text{V}$ | 0.5 | 1.6 | 6.5 | |
| t_{DIS} | OE | Y | $1.8\text{V} \pm 0.15\text{V}$ | 1.0 | 4.3 | 12.0 | ns |
| | | | $2.5\text{V} \pm 0.2\text{V}$ | 0.5 | 2.7 | 7.0 | |
| | | | 2.7V | 0.5 | 3.4 | 7.0 | |
| | | | $3.3\text{V} \pm 0.3\text{V}$ | 0.5 | 3.0 | 7.0 | |
| | | | $5.0\text{V} \pm 0.5\text{V}$ | 0.5 | 2.2 | 5.5 | |

Operating Characteristics

 $T_A = +25^\circ\text{C}$

| Parameter | | | Test Conditions | $V_{CC} = 1.8\text{V}$ | $V_{CC} = 2.5\text{V}$ | $V_{CC} = 3.3\text{V}$ | $V_{CC} = 5\text{V}$ | Unit |
|-----------|-------------------------------|------------------|--------------------|------------------------|------------------------|------------------------|----------------------|------|
| | | | | Typ | Typ | Typ | Typ | |
| C_{PD} | Power Dissipation Capacitance | Outputs Enabled | $f = 10\text{MHz}$ | 19 | 19 | 19 | 21 | pF |
| | | Outputs Disabled | | 2 | 2 | 3 | 4 | |

Parameter Measurement Information

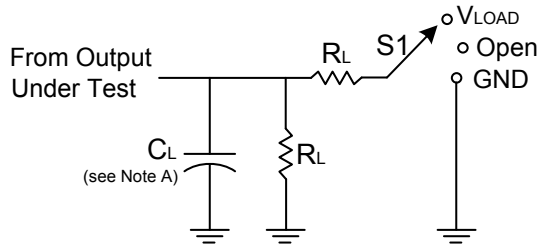

| TEST | S1 |
|-------------------|------------|
| t_{PLH}/t_{PHL} | Open |
| t_{PLZ}/t_{PZL} | V_{LOAD} |
| t_{PHZ}/t_{PZH} | GND |

| V_{CC} | Inputs | | V_M | V_{LOAD} | C_L | R_L | V_{Δ} |
|------------|----------|-----------|------------|-------------------|-------|-------|--------------|
| | V_I | t_R/t_F | | | | | |
| 1.8V±0.15V | V_{CC} | ≤2ns | $V_{CC}/2$ | $2 \times V_{CC}$ | 30pF | 1kΩ | 0.15V |
| 2.5V±0.2V | V_{CC} | ≤2ns | $V_{CC}/2$ | $2 \times V_{CC}$ | 30pF | 500Ω | 0.15V |
| 2.7V | 2.7V | ≤2.5ns | 1.5V | 6V | 50pF | 500Ω | 0.3V |
| 3.3V±0.3V | 3V | ≤2.5ns | 1.5V | 6V | 50pF | 500Ω | 0.3V |
| 5V±0.5V | V_{CC} | ≤2.5ns | $V_{CC}/2$ | $2 \times V_{CC}$ | 50pF | 500Ω | 0.3V |

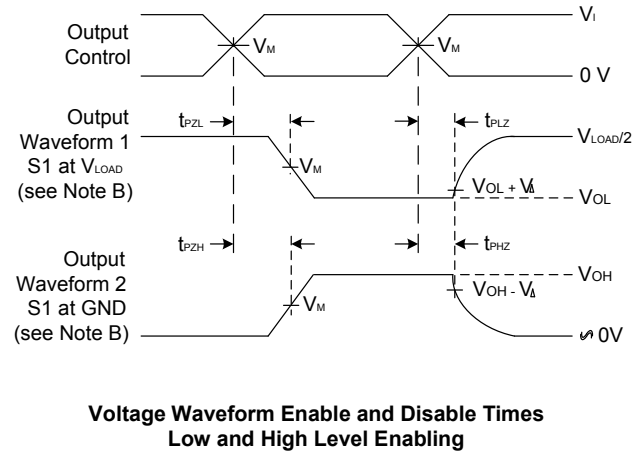
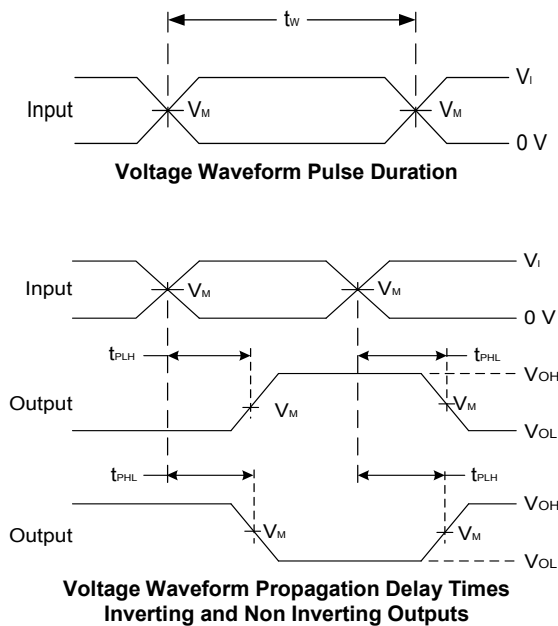
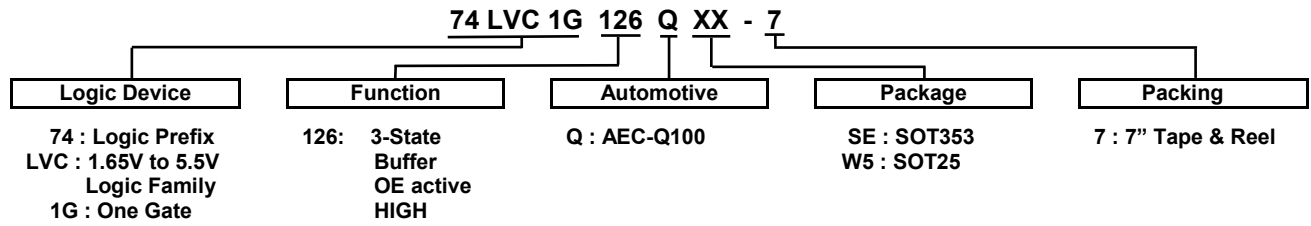

Figure 1. Load Circuit and Voltage Waveforms

- Notes:
- A. Includes test lead and test apparatus capacitance.
 - B. All pulses are supplied at pulse repetition rate ≤ 10MHz.
 - C. Inputs are measured separately one transition per measurement.
 - D. t_{PLZ} and t_{PZH} are the same as t_{DIS} .
 - E. t_{PZL} and t_{PZH} are the same as t_{EN} .
 - F. t_{PLH} and t_{PHL} are the same as t_{PD} .

Ordering Information (Note 8)



| Part Number | Package Code | Package (Notes 9 & 10) | Package Size | 7" Tape and Reel | |
|-----------------|--------------|------------------------|---|------------------|--------------------|
| | | | | Quantity | Part Number Suffix |
| 74LVC1G126QSE-7 | SE | SOT353 | 2.15mm × 2.1mm × 1.1mm 0.65mm lead pitch | 3000/Tape & Reel | -7 |
| 74LVC1G126QW5-7 | W5 | SOT25 | 3.0mm × 2.8mm × 1.2mm 0.95mm lead pitch | 3000/Tape & Reel | -7 |

Notes: 8. For packaging details, go to our website at <https://www.diodes.com/design/support/packaging/diodes-packaging/>.
 9. Pad layout as shown in Diodes Incorporated's package outline PDFs, which can be found on our website at <http://www.diodes.com/package-outlines.html>.
 10. The taping orientation is located on our website at <https://www.diodes.com/assets/Packaging-Support-Docs/ap02007.pdf>.

Marking Information

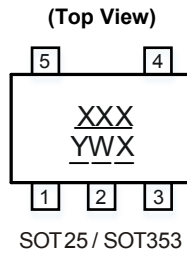

XXX : Identification Code
Y : Year 0~9
W : Week: A~Z 1~26 week
 a~z 27~52 week
 z represents week 52 and 53
X : A~Z: Internal Code

| Part Number | Package | Identification Code |
|-----------------|---------|---------------------|
| 74LVC1G126QW5-7 | SOT25 | UZQ |
| 74LVC1G126QSE-7 | SOT353 | UZQ |

Package Outline Dimensions

Please see <http://www.diodes.com/package-outlines.html> for the latest version.

(1) Package Type: SOT25

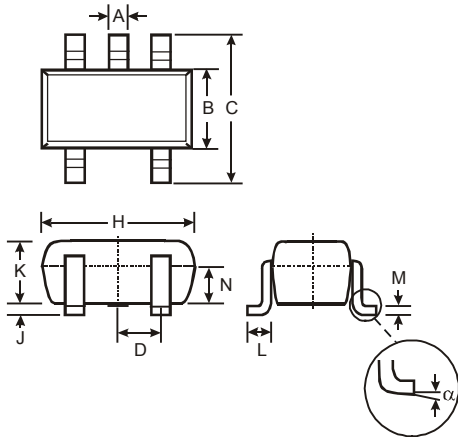

| SOT25 | | | |
|----------------------|-------|------|------|
| Dim | Min | Max | Typ |
| A | 0.35 | 0.50 | 0.38 |
| B | 1.50 | 1.70 | 1.60 |
| C | 2.70 | 3.00 | 2.80 |
| D | - | - | 0.95 |
| H | 2.90 | 3.10 | 3.00 |
| J | 0.013 | 0.10 | 0.05 |
| K | 1.00 | 1.30 | 1.10 |
| L | 0.35 | 0.55 | 0.40 |
| M | 0.10 | 0.20 | 0.15 |
| N | 0.70 | 0.80 | 0.75 |
| α | 0° | 8° | - |
| All Dimensions in mm | | | |

(2) Package Type: SOT353

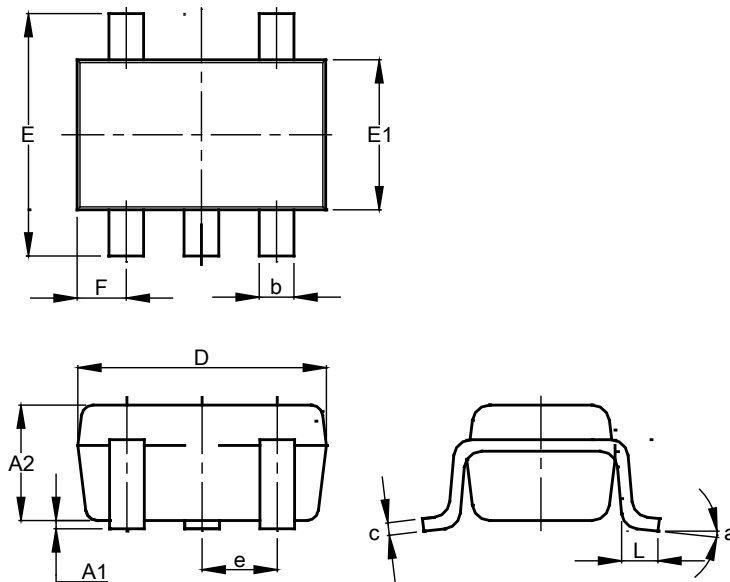

| SOT353 | | | |
|----------------------|-----------|------|-------|
| Dim | Min | Max | Typ |
| A1 | 0.00 | 0.10 | 0.05 |
| A2 | 0.90 | 1.00 | 0.95 |
| b | 0.10 | 0.30 | 0.25 |
| c | 0.10 | 0.22 | 0.11 |
| D | 1.80 | 2.20 | 2.15 |
| E | 2.00 | 2.20 | 2.10 |
| E1 | 1.15 | 1.35 | 1.30 |
| e | 0.650 BSC | | |
| F | 0.40 | 0.45 | 0.425 |
| L | 0.25 | 0.40 | 0.30 |
| a | 0° | 8° | -- |
| All Dimensions in mm | | | |

Suggested Pad Layout

Please see <http://www.diodes.com/package-outlines.html> for the latest version.

(1) Package Type: SOT25

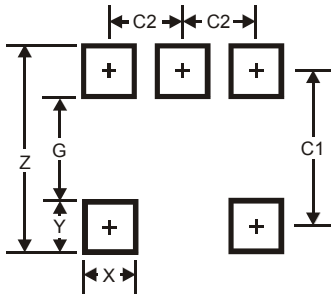

| Dimensions | Value |
|------------|-------|
| Z | 3.20 |
| G | 1.60 |
| X | 0.55 |
| Y | 0.80 |
| C1 | 2.40 |
| C2 | 0.95 |

(2) Package Type: SOT353

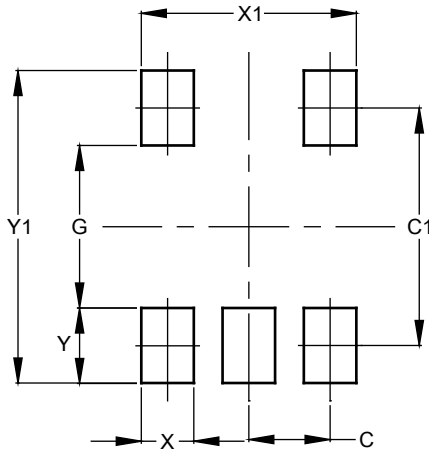

| Dimensions | Value (in mm) |
|------------|---------------|
| C | 0.650 |
| C1 | 1.900 |
| G | 1.300 |
| X | 0.420 |
| X1 | 1.720 |
| Y | 0.600 |
| Y1 | 2.500 |

Mechanical Data

SOT25

- Moisture Sensitivity: Level 1 per J-STD-020
- Terminals: Finish – Matte Tin Plated Leads, Solderable per MIL-STD-202, Method 208 [Ⓔ]
- Weight: 0.0158 grams (Approximate)

SOT353

- Moisture Sensitivity: Level 1 per J-STD-020
- Terminals: Finish – Matte Tin Plated Leads, Solderable per MIL-STD-202, Method 208 [Ⓔ]
- Weight: 0.0064 grams (Approximate)

IMPORTANT NOTICE

1. DIODES INCORPORATED AND ITS SUBSIDIARIES (“DIODES”) MAKE NO WARRANTY OF ANY KIND, EXPRESS OR IMPLIED, WITH REGARDS TO ANY INFORMATION CONTAINED IN THIS DOCUMENT, INCLUDING, BUT NOT LIMITED TO, THE IMPLIED WARRANTIES OF MERCHANTABILITY, FITNESS FOR A PARTICULAR PURPOSE OR NON-INFRINGEMENT OF THIRD PARTY INTELLECTUAL PROPERTY RIGHTS (AND THEIR EQUIVALENTS UNDER THE LAWS OF ANY JURISDICTION).
2. The Information contained herein is for informational purpose only and is provided only to illustrate the operation of Diodes products described herein and application examples. Diodes does not assume any liability arising out of the application or use of this document or any product described herein. This document is intended for skilled and technically trained engineering customers and users who design with Diodes products. Diodes products may be used to facilitate safety-related applications; however, in all instances customers and users are responsible for (a) selecting the appropriate Diodes products for their applications, (b) evaluating the suitability of the Diodes products for their intended applications, (c) ensuring their applications, which incorporate Diodes products, comply the applicable legal and regulatory requirements as well as safety and functional-safety related standards, and (d) ensuring they design with appropriate safeguards (including testing, validation, quality control techniques, redundancy, malfunction prevention, and appropriate treatment for aging degradation) to minimize the risks associated with their applications.
3. Diodes assumes no liability for any application-related information, support, assistance or feedback that may be provided by Diodes from time to time. Any customer or user of this document or products described herein will assume all risks and liabilities associated with such use, and will hold Diodes and all companies whose products are represented herein or on Diodes’ websites, harmless against all damages and liabilities.
4. Products described herein may be covered by one or more United States, international or foreign patents and pending patent applications. Product names and markings noted herein may also be covered by one or more United States, international or foreign trademarks and trademark applications. Diodes does not convey any license under any of its intellectual property rights or the rights of any third parties (including third parties whose products and services may be described in this document or on Diodes’ website) under this document.
5. Diodes products are provided subject to Diodes’ Standard Terms and Conditions of Sale (<https://www.diodes.com/about/company/terms-and-conditions/terms-and-conditions-of-sales/>) or other applicable terms. This document does not alter or expand the applicable warranties provided by Diodes. Diodes does not warrant or accept any liability whatsoever in respect of any products purchased through unauthorized sales channel.
6. Diodes products and technology may not be used for or incorporated into any products or systems whose manufacture, use or sale is prohibited under any applicable laws and regulations. Should customers or users use Diodes products in contravention of any applicable laws or regulations, or for any unintended or unauthorized application, customers and users will (a) be solely responsible for any damages, losses or penalties arising in connection therewith or as a result thereof, and (b) indemnify and hold Diodes and its representatives and agents harmless against any and all claims, damages, expenses, and attorney fees arising out of, directly or indirectly, any claim relating to any noncompliance with the applicable laws and regulations, as well as any unintended or unauthorized application.
7. While efforts have been made to ensure the information contained in this document is accurate, complete and current, it may contain technical inaccuracies, omissions and typographical errors. Diodes does not warrant that information contained in this document is error-free and Diodes is under no obligation to update or otherwise correct this information. Notwithstanding the foregoing, Diodes reserves the right to make modifications, enhancements, improvements, corrections or other changes without further notice to this document and any product described herein. This document is written in English but may be translated into multiple languages for reference. Only the English version of this document is the final and determinative format released by Diodes.
8. Any unauthorized copying, modification, distribution, transmission, display or other use of this document (or any portion hereof) is prohibited. Diodes assumes no responsibility for any losses incurred by the customers or users or any third parties arising from any such unauthorized use.

Copyright © 2021 Diodes Incorporated

www.diodes.com

X-ON Electronics

Largest Supplier of Electrical and Electronic Components

Click to view similar products for [Buffers & Line Drivers](#) category:

Click to view products by [Diodes Incorporated](#) manufacturer:

Other Similar products are found below :

[74AUP2G34FW3-7](#) [HEF4043BP](#) [NL17SG125DFT2G](#) [PI74FCT3244L](#) [MC74HCT365ADTR2G](#) [Le87401NQC](#) [Le87402MQC](#) [028192B](#)
[042140C](#) [051117G](#) [070519XB](#) [NL17SZ07P5T5G](#) [NLU1GT126AMUTCG](#) [74AUP1G17FW5-7](#) [74LVC2G17FW4-7](#) [CD4502BE](#) [5962-](#)
[8982101PA](#) [5962-9052201PA](#) [74LVC1G125FW4-7](#) [NL17SH17P5T5G](#) [NLV37WZ17USG](#) [NL17SH125P5T5G](#) [NLV37WZ07USG](#)
[RHRXH162244K1](#) [74AUP1G34FW5-7](#) [74AUP1G07FW5-7](#) [74LVC1G126FW4-7](#) [74LVC2G126RA3-7](#) [NLX2G17CMUTCG](#)
[74LVCE1G125FZ4-7](#) [Le87501NQC](#) [74AUP1G126FW5-7](#) [TC74HC4050AP\(F\)](#) [74LVCE1G07FZ4-7](#) [NLX3G16DMUTCG](#)
[NLX2G06AMUTCG](#) [NLVVHC1G50DFT2G](#) [LE87100NQC](#) [LE87100NQCT](#) [LE87290YQC](#) [LE87290YQCT](#) [LE87511NQC](#) [LE87511NQCT](#)
[LE87557NQC](#) [LE87557NQCT](#) [LE87614MQC](#) [LE87614MQCT](#) [74AUP1G125FW5-7](#) [NLU2G16CMUTCG](#) [MC74LCX244MN2TWG](#)