

Description

The 74LVC3G17 is a triple Schmitt-trigger buffer with standard push-pull outputs. The device is designed for operation with a power supply range of 1.65V to 5.5V. The inputs are tolerant to 5.5V allowing this device to be used in a mixed voltage environment. The device is fully specified for partial power down applications using I_{OFF}. The I_{OFF} circuitry disables the output preventing damaging current backflow when the device is powered down.

Each of the buffers performs the positive Boolean function:

$$Y = A$$

Features

- Wide Supply Voltage Range from 1.65V to 5.5V
- ±24mA Output Drive at 3.3V
- CMOS Low-Power Consumption
- I_{OFF} Supports Partial Power Down Mode Operation
- Inputs Accept up to 5.5V
- ESD Protection Tested per JESD 22
Exceeds 2000V Human Body Model (A114)
Exceeds 1000V Charged Device Model (C101)
- Latch-Up Exceeds 100mA per JESD 78, Class I
- Range of Package Options
- **Totally Lead-Free & Fully RoHS Compliant (Notes 1 & 2)**
- **Halogen and Antimony Free. "Green" Device (Note 3)**
- **For automotive applications requiring specific change control (i.e. parts qualified to AEC-Q100/101/104/200, PPAP capable, and manufactured in IATF 16949 certified facilities), please [contact us](https://www.diodes.com/quality/product-definitions/) or your local Diodes representative.**
<https://www.diodes.com/quality/product-definitions/>

- Notes:
1. No purposely added lead. Fully EU Directive 2002/95/EC (RoHS), 2011/65/EU (RoHS 2) & 2015/863/EU (RoHS 3) compliant.
 2. See <https://www.diodes.com/quality/lead-free/> for more information about Diodes Incorporated's definitions of Halogen- and Antimony-free, "Green" and Lead-free.
 3. Halogen- and Antimony-free "Green" products are defined as those which contain <900ppm bromine, <900ppm chlorine (<1500ppm total Br + Cl) and <1000ppm antimony compounds.

Pin Assignments

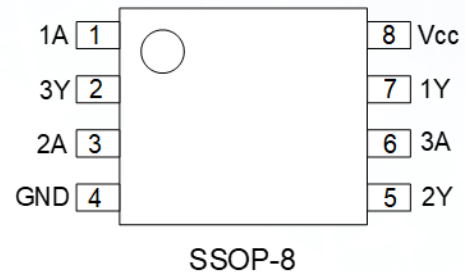

SSOP-8

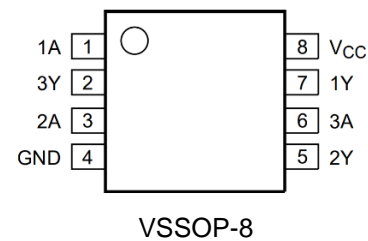

VSSOP-8

Applications

- Voltage-level shifting
- General-purpose logic
- Power down signal isolation
- Wide array of products such as:
 - PCs, networking, notebooks, netbooks, PDAs
 - Computer peripherals, hard drives, CD/DVD ROM
 - TV, DVD, DVR, set top boxes
 - Cell phones, personal navigation/GPS
 - MP3 players, cameras, video recorders

Pin Descriptions

Pin Name	Pin NO.	Description
1A	1	Data Input
3Y	2	Data Output
2A	3	Data Input
GND	4	Ground
2Y	5	Data Output
3A	6	Data Input
1Y	7	Data Output
Vcc	8	Supply Voltage

Logic Diagram

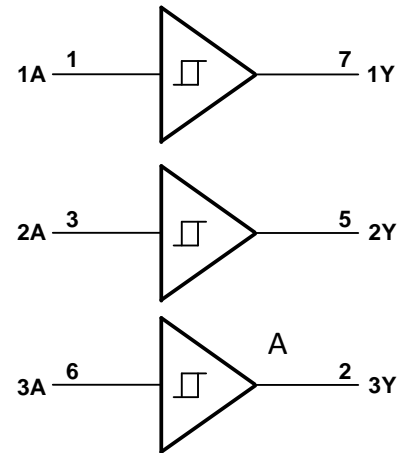

Function Table

Inputs	Output
A	Y
H	H
L	L

Absolute Maximum Ratings (Notes 4, 5)

Symbol	Description	Rating	Unit
ESD HBM	Human Body Model ESD Protection	2	kV
ESD CDM	Charged Device Model ESD Protection	1	kV
V _{CC}	Supply Voltage Range	-0.5 to 6.5	V
V _I	Input Voltage Range	-0.5 to 6.5	V
V _O	Voltage Applied to Output in High Impedance or I _{OFF} State	-0.5 to 6.5	V
V _O	Voltage Applied to Output in High or Low State	-0.5 to V _{CC} + 0.5	V
I _{IK}	Input Clamp Current V _I < 0	-50	mA
I _{OK}	Output Clamp Current V _O < 0	-50	mA
I _O	Continuous Output Current	±50	mA
I _{CC} , I _{GND}	Continuous Current Through V _{CC} or GND	±100	mA
T _J	Junction Temperature	+150	°C
T _{STG}	Storage Temperature	-65 to +150	°C

- Notes:
- Stresses beyond the absolute maximum can result in immediate failure or reduced reliability. These are stress values and device operation should be within recommended values.
 - Forcing the maximum allowed voltage could cause a condition exceeding the maximum current or conversely forcing the maximum current could cause a condition exceeding the maximum voltage. The ratings of both current and voltage must be maintained within the controlled range.

Recommended Operating Conditions (Note 6)

Symbol	Parameter	Conditions	Min	Max	Unit
V _{CC}	Operating Voltage	Operating	1.65	5.5	V
		Data Retention Only	1.5	—	
V _I	Input Voltage	—	0	5.5	V
V _O	Output Voltage	V _{CC} = 1.65V to 5.5V	0	V _{CC}	V
I _{OH}	High-Level Output Current	V _{CC} = 1.65V	—	-4	mA
		V _{CC} = 2.3V	—	-8	
		V _{CC} = 3V	—	-16	
		V _{CC} = 4.5V	—	-24	
I _{OL}	Low-Level Output Current	V _{CC} = 1.65V	—	4	mA
		V _{CC} = 2.3V	—	8	
		V _{CC} = 3V	—	16	
		V _{CC} = 4.5V	—	24	
T _A	Operating Free-Air Temperature	—	-40	+125	°C

Note: 6. Unused inputs should be held at V_{CC} or Ground for device proper operation.

Electrical Characteristics

Symbol	Parameter	Test Conditions	V _{CC}	-40°C to +85°C		-40°C to +125°C		Unit
				Min	Max	Min	Max	
V _{T+}	Positive-Going Input Threshold Voltage	—	1.65V	0.79	1.16	0.79	1.16	V
		—	2.3V	1.11	1.56	1.11	1.56	
		—	3V	1.5	1.87	1.5	1.87	
		—	4.5V	2.16	2.74	2.16	2.74	
		—	5.5V	2.61	3.33	2.61	3.33	
V _{T-}	Negative-Going Input Threshold Voltage	—	1.65V	0.39	0.62	0.39	0.62	V
		—	2.3V	0.58	0.87	0.58	0.87	
		—	3V	0.84	1.14	0.84	1.14	
		—	4.5V	1.41	1.79	1.41	1.79	
		—	5.5V	1.87	2.29	1.87	1.29	
ΔV _T	Hysteresis (V _{T+} - V _{T-})	—	1.65V	0.37	0.62	0.37	0.62	V
		—	2.3V	0.48	0.77	0.48	0.77	
		—	3V	0.56	0.87	0.56	0.87	
		—	4.5V	0.71	1.04	0.71	1.04	
		—	5.5V	0.71	1.11	0.71	1.11	
V _{OH}	High-Level Output Voltage	I _{OH} = -100μA	1.65V to 5.5V	V _{CC} - 0.1	—	V _{CC} - 0.1	—	V
		I _{OH} = -4mA	1.65V	1.2	—	1.2	—	
		I _{OH} = -8mA	2.3V	1.9	—	1.9	—	
		I _{OH} = -16mA	3V	2.4	—	2.4	—	
		I _{OH} = -24mA		2.3	—	2.3	—	
		I _{OH} = -32mA	4.5V	3.8	—	3.8	—	
V _{OL}	Low-Level Output Voltage	I _{OL} = 100μA	1.65V to 5.5V	—	0.1	—	0.1	V
		I _{OL} = 4mA	1.65V	—	0.45	—	0.45	
		I _{OL} = 8mA	2.3V	—	0.3	—	0.3	
		I _{OL} = 16mA	3V	—	0.4	—	0.4	
		I _{OL} = 24mA		—	0.55	—	0.55	
		I _{OL} = 32mA	4.5V	—	0.55	—	0.55	
I _I	Input Current	V _I = 5.5V or GND	0 to 5.5V	—	±1	—	±5	μA
I _{OFF}	Power Down Leakage Current	V _I or V _O = 5.5V	0	—	±5	—	±10	μA
I _{CC}	Supply Current	V _I = 5.5V or GND, I _O = 0	1.65V to 5.5V	—	10	—	10	μA
ΔI _{CC}	Additional Supply Current	Input at V _{CC} - 0.6V	3V to 5.5V	—	500	—	500	μA
C _I	Input Capacitance	V _I = V _{CC} or GND	3.3V	—	4 (Typ)	—	—	pF

Package Characteristics

Symbol	Parameter	Package	Test Conditions	Min	Typ	Max	Unit
θ _{JA}	Thermal Resistance Junction-to-Ambient	SSOP-8	Note 7	—	130	—	°C/W
		VSSOP-8	Note 7	—	155	—	°C/W
θ _{JC}	Thermal Resistance Junction-to-Case	SSOP-8	Note 7	—	36	—	°C/W
		VSSOP-8	Note 7	—	38	—	°C/W

Note: 7. Test condition: Device mounted on JEDEC 2s2p High-K board, FR-4 substrate PCB, 2oz copper with minimum recommended pad layout.

Operating Characteristics (T_A = +25°C)

Symbol	Parameter	Test Conditions	V _{CC} = 1.8V	V _{CC} = 2.5V	V _{CC} = 3.3V	V _{CC} = 5V	Unit
			Typ	Typ	Typ	Typ	
C _{PD}	Power Dissipation Capacitance	f = 10MHz, 1 Input Switching	18	19	19	22	pF

Switching Characteristics

Figure 1

Parameter	From Input	To Output	V _{CC}	T _A = -40°C to +85°C		T _A = -40°C to +125°C		Unit
				Min	Max	Min	Max	
t _{PD}	A	Y	1.8V ± 0.15V	4.3	9.2	4.3	10.2	ns
			2.5V ± 0.2V	2.0	6.2	2.0	7.2	
			3.3V ± 0.3V	1.2	5.4	1.2	6.4	
			5.0V ± 0.5V	1.0	4.1	1.0	5.1	

Parameter Measurement Information (Notes B, C, D)

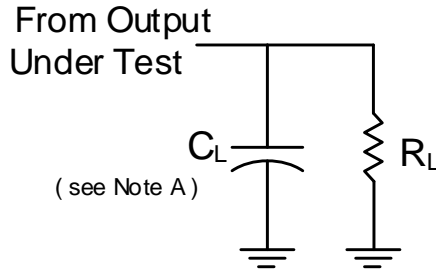

V _{CC}	Inputs		V _M	C _L	R _L
	V _I	t _r /t _f			
1.8V ± 0.15V	V _{CC}	≤2ns	V _{CC} / 2	30pF	1kΩ
2.5V ± 0.2V	V _{CC}	≤2ns	V _{CC} / 2	30pF	500Ω
3.3V ± 0.3V	3V	≤2.5ns	1.5V	50pF	500Ω
5.0V ± 0.5V	V _{CC}	≤2.5ns	V _{CC} / 2	50pF	500Ω

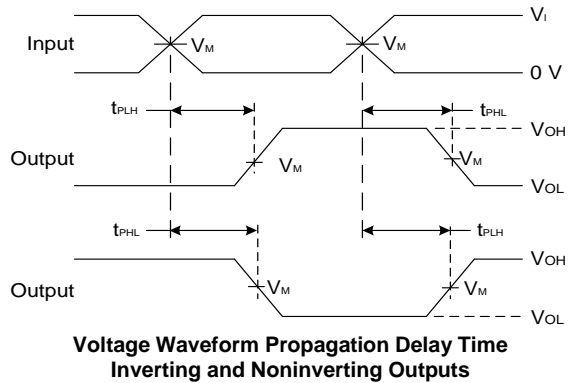
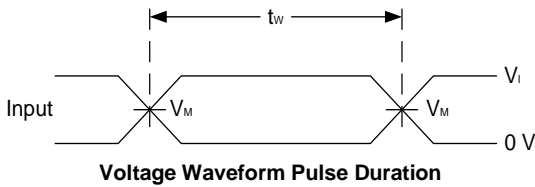
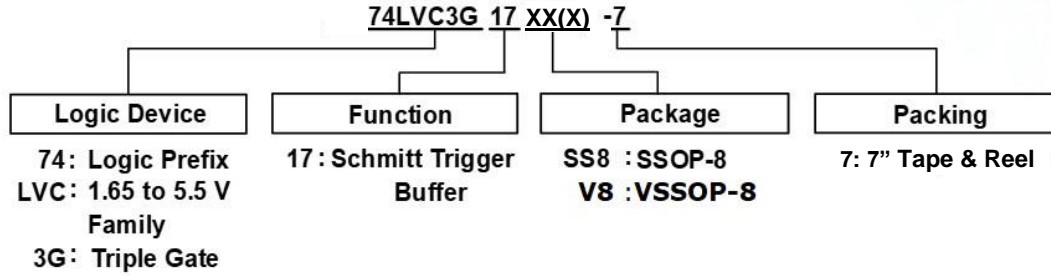

Figure 1. Load Circuit and Voltage Waveforms

- Notes:
- A. Includes test lead and test apparatus capacitance.
 - B. All pulses are supplied at pulse repetition rate ≤ 10MHz.
 - C. Inputs are measured separately one transition per measurement.
 - D. t_{PLH} and t_{PHL} are the same as t_{PD}.

Ordering Information



Part Number	Package Code	Package	Packing	
			Qty.	Carrier
74LVC3G17SS8-7	SS8	SSOP-8	3000	7" Tape and Reel (Note 8)
74LVC3G17V8-7	V8	VSSOP-8	3000	7" Tape and Reel (Note 8)

Note: 8. The taping orientation is located on our website at <http://www.diodes.com/package-outlines.html>.

Marking Information

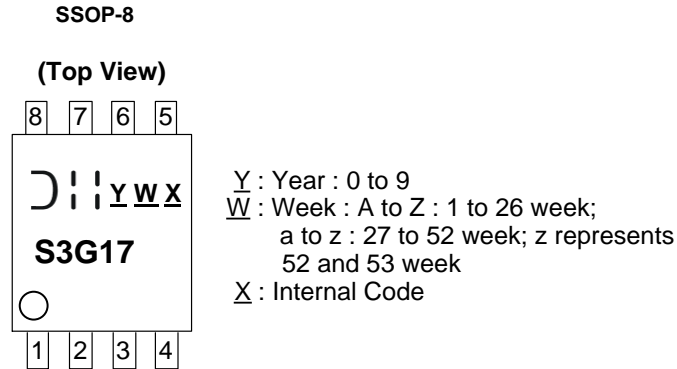

Part Number	Package	Identification Code
74LVC3G17SS8-7	SSOP-8	S3G17

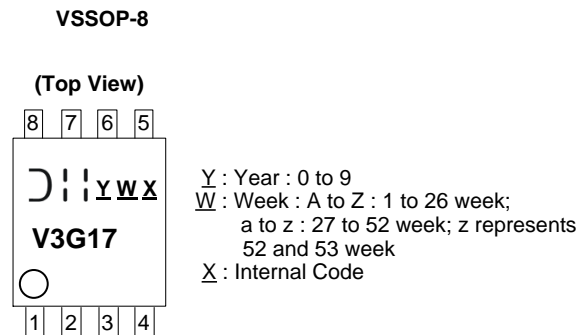

Part Number	Package	Identification Code
74LVC3G17V8-7	VSSOP-8	V3G17

Package Outline Dimensions

Please see <http://www.diodes.com/package-outlines.html> for the latest version.

SSOP-8

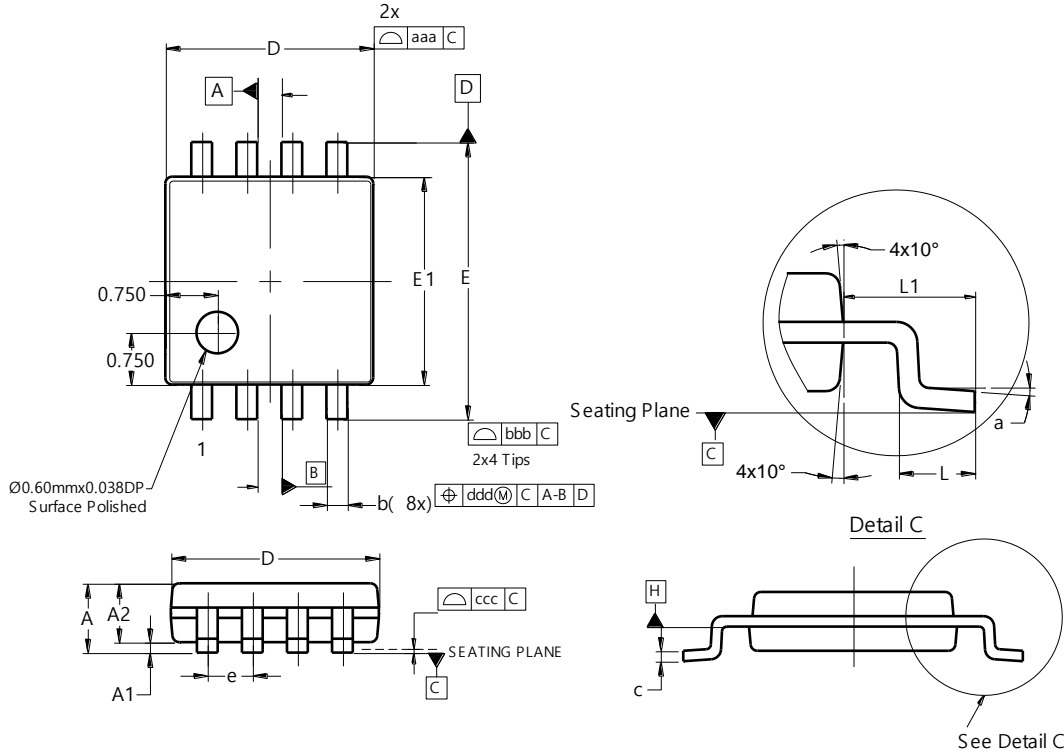

SSOP-8			
Dim	Min	Max	Typ
A	--	1.30	--
A1	0.05	0.15	--
A2	0.95	1.20	1.05
b	0.15	0.30	0.225
c	0.08	0.23	--
D	2.75	3.15	2.95
E	3.75	4.25	4.00
E1	2.70	2.90	2.80
e	--	--	0.65
L	0.20	0.60	0.40
L1	0.525	0.675	0.60
a	0°	8°	4°
aaa	0.20		
bbb	0.25		
ccc	0.10		
ddd	0.13		
All Dimensions in mm			

VSSOP-8

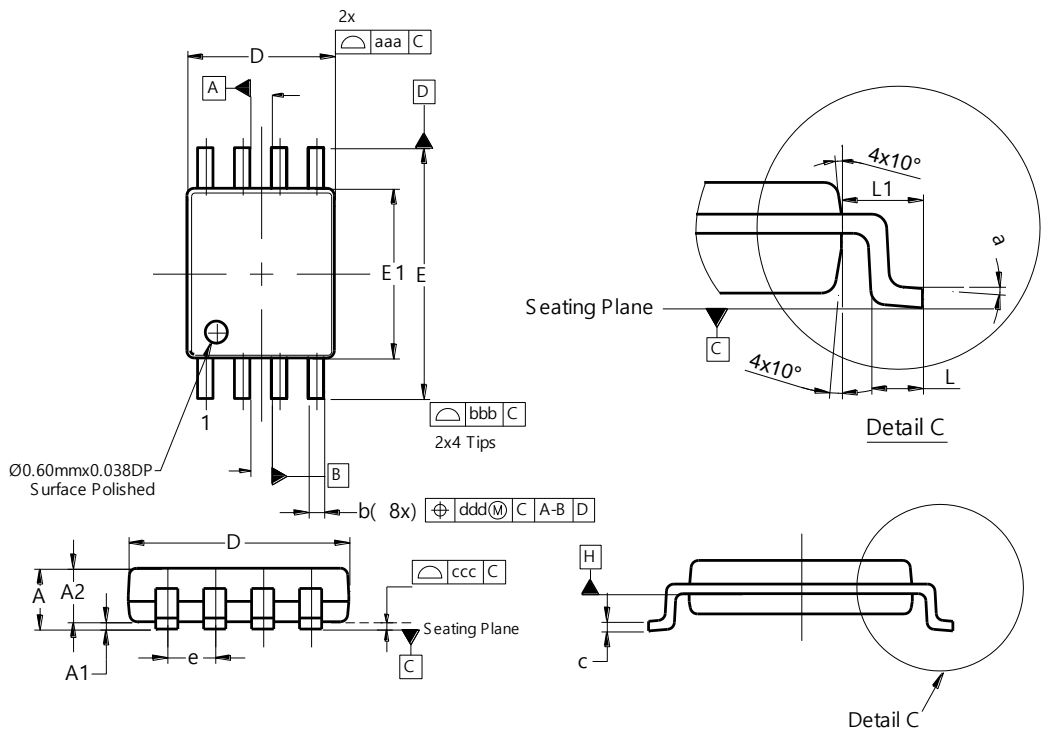

VSSOP-8			
Dim	Min	Max	Typ
A	0.60	0.90	--
A1	--	0.10	--
A2	0.60	0.80	--
b	0.17	0.25	0.21
c	0.08	0.13	--
D	1.90	2.10	2.00
E	3.20	3.60	3.40
E1	2.20	2.40	2.30
e	--	--	0.50
L	0.30	0.40	0.35
L1	0.50	0.60	0.55
a	0°	6°	3°
aaa	0.20		
bbb	0.25		
ccc	0.10		
ddd	0.13		
All Dimensions in mm			

Suggested Pad Layout

Please see <http://www.diodes.com/package-outlines.html> for the latest version.

SSOP-8

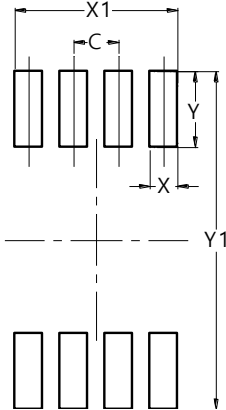

Dimensions	Value (in mm)
C	0.650
X	0.400
X1	2.350
Y	1.100
Y1	4.900

VSSOP-8

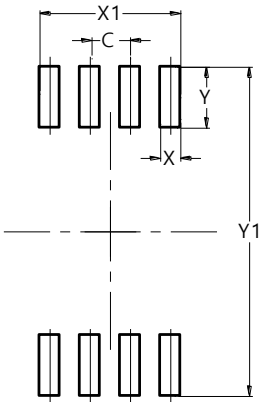

Dimensions	Value (in mm)
C	0.500
X	0.250
X1	1.750
Y	0.750
Y1	4.050

Mechanical Data

SSOP-8

- Moisture Sensitivity: Level 1 per J-STD-020
- Terminals: Finish - Mate Tin Plated Leads, Solderable per MIL-STD-202, Method 208 [Ⓔ]3
- Weight: 0.0169 grams (Approximate)

VSSOP-8

- Moisture Sensitivity: Level 1 per J-STD-020
- Terminals: Finish - Mate Tin Plated Leads, Solderable per MIL-STD-202, Method 208 [Ⓔ]3
- Weight: 0.011 grams (Approximate)

IMPORTANT NOTICE

1. DIODES INCORPORATED (Diodes) AND ITS SUBSIDIARIES MAKE NO WARRANTY OF ANY KIND, EXPRESS OR IMPLIED, WITH REGARDS TO ANY INFORMATION CONTAINED IN THIS DOCUMENT, INCLUDING, BUT NOT LIMITED TO, THE IMPLIED WARRANTIES OF MERCHANTABILITY, FITNESS FOR A PARTICULAR PURPOSE OR NON-INFRINGEMENT OF THIRD PARTY INTELLECTUAL PROPERTY RIGHTS (AND THEIR EQUIVALENTS UNDER THE LAWS OF ANY JURISDICTION).
2. The Information contained herein is for informational purpose only and is provided only to illustrate the operation of Diodes' products described herein and application examples. Diodes does not assume any liability arising out of the application or use of this document or any product described herein. This document is intended for skilled and technically trained engineering customers and users who design with Diodes' products. Diodes' products may be used to facilitate safety-related applications; however, in all instances customers and users are responsible for (a) selecting the appropriate Diodes products for their applications, (b) evaluating the suitability of Diodes' products for their intended applications, (c) ensuring their applications, which incorporate Diodes' products, comply the applicable legal and regulatory requirements as well as safety and functional-safety related standards, and (d) ensuring they design with appropriate safeguards (including testing, validation, quality control techniques, redundancy, malfunction prevention, and appropriate treatment for aging degradation) to minimize the risks associated with their applications.
3. Diodes assumes no liability for any application-related information, support, assistance or feedback that may be provided by Diodes from time to time. Any customer or user of this document or products described herein will assume all risks and liabilities associated with such use, and will hold Diodes and all companies whose products are represented herein or on Diodes' websites, harmless against all damages and liabilities.
4. Products described herein may be covered by one or more United States, international or foreign patents and pending patent applications. Product names and markings noted herein may also be covered by one or more United States, international or foreign trademarks and trademark applications. Diodes does not convey any license under any of its intellectual property rights or the rights of any third parties (including third parties whose products and services may be described in this document or on Diodes' website) under this document.
5. Diodes' products are provided subject to Diodes' Standard Terms and Conditions of Sale (<https://www.diodes.com/about/company/terms-and-conditions/terms-and-conditions-of-sales/>) or other applicable terms. This document does not alter or expand the applicable warranties provided by Diodes. Diodes does not warrant or accept any liability whatsoever in respect of any products purchased through unauthorized sales channel.
6. Diodes' products and technology may not be used for or incorporated into any products or systems whose manufacture, use or sale is prohibited under any applicable laws and regulations. Should customers or users use Diodes' products in contravention of any applicable laws or regulations, or for any unintended or unauthorized application, customers and users will (a) be solely responsible for any damages, losses or penalties arising in connection therewith or as a result thereof, and (b) indemnify and hold Diodes and its representatives and agents harmless against any and all claims, damages, expenses, and attorney fees arising out of, directly or indirectly, any claim relating to any noncompliance with the applicable laws and regulations, as well as any unintended or unauthorized application.
7. While efforts have been made to ensure the information contained in this document is accurate, complete and current, it may contain technical inaccuracies, omissions and typographical errors. Diodes does not warrant that information contained in this document is error-free and Diodes is under no obligation to update or otherwise correct this information. Notwithstanding the foregoing, Diodes reserves the right to make modifications, enhancements, improvements, corrections or other changes without further notice to this document and any product described herein. This document is written in English but may be translated into multiple languages for reference. Only the English version of this document is the final and determinative format released by Diodes.
8. Any unauthorized copying, modification, distribution, transmission, display or other use of this document (or any portion hereof) is prohibited. Diodes assumes no responsibility for any losses incurred by the customers or users or any third parties arising from any such unauthorized use.
9. This Notice may be periodically updated with the most recent version available at <https://www.diodes.com/about/company/terms-and-conditions/important-notice>

The Diodes logo is a registered trademark of Diodes Incorporated in the United States and other countries.
All other trademarks are the property of their respective owners.
© 2023 Diodes Incorporated. All Rights Reserved.

www.diodes.com

X-ON Electronics

Largest Supplier of Electrical and Electronic Components

Click to view similar products for [Buffers & Line Drivers](#) category:

Click to view products by [Diodes Incorporated](#) manufacturer:

Other Similar products are found below :

[LXV200-024SW](#) [74AUP2G34FW3-7](#) [HEF4043BP](#) [NL17SG125DFT2G](#) [NLU1GT126CMUTCG](#) [CD4041UBE](#) [54FCT240CTDB](#)
[74HCT540N](#) [DS14C88N](#) [070519XB](#) [NL17SZ07P5T5G](#) [74LVC2G17FW4-7](#) [CD4502BE](#) [5962-8982101PA](#) [61446R00](#) [74LVCE1G126FZ4-7](#)
[NL17SH17P5T5G](#) [74HCT126T14-13](#) [74LVC2G34FW4-7](#) [74VHC9126FT\(BJ\)](#) [RHRXH162244K1](#) [74AUP1G34FW5-7](#) [74LVC1G126FW4-7](#)
[74LVC2G126RA3-7](#) [74LVCE1G125FZ4-7](#) [74AUP1G126FW5-7](#) [54FCT240TLB](#) [74LVCE1G07FZ4-7](#) [NLX3G16DMUTCG](#)
[NLX2G06AMUTCG](#) [LE87100NQCT](#) [LE87285NQC](#) [LE87290YQC](#) [LE87290YQCT](#) [74AUP1G125FW5-7](#) [NLU2G16CMUTCG](#)
[MC74LCX244MN2TWG](#) [NL17SG17P5T5G](#) [NLV74HC125ADR2G](#) [NLVHCT245ADTR2G](#) [NLVVHC1G126DFT2G](#) [EL5623IRZ](#)
[ISL1539IRZ-T13](#) [MC100EP17MNG](#) [MC74HCT365ADR2G](#) [MC74LCX244ADTR2G](#) [NL27WZ126US](#) [NL37WZ16US](#) [NLU1G07MUTCG](#)
[NLU2G07MUTCG](#)