

Two Phase Dual-coil High Voltage Smart Fan Motor Driver with FG/RD AH9281/82

General Description

The AH9281/82 is a one-chip solution for driving two-coil brushless DC motors and fans.

Based on the advanced CDMOS process, the IC contains a Hall-effect sensor, dynamic offset correction and powerful output drivers with 1200mA peak output current capability.

Specially designed for driving large fans, the device is optimized for low start-up voltage. Frequency Generator or Rotation Detection is available. The open drain output makes easier the connectivity with any external interface such as hardware monitoring or Super I/O IC.

The AH9281/82 is available in TO-95 and SOT-89-5 packages.

Features

- High Sensitivity Integrated Hall Sensor
- Low Start-up Voltage
- 5V and 12V Operation
- Peak Output Current up to 1200mA
- Power Efficient CMOS and Power MOSFETs
- Built-in Output Protection Clamping Diode
- Locked Rotor Shutdown and Auto-restart
- Integrated Tachometer (AH9281) or Alarm (AH9282) Signal Output
- ESD Rating: 6000V (Human Body Model)
400V (Machine Model)

Applications

- 5V/12V DC Brushless Motor/Fan
- PC, Server, Laptop Cooling Fan
- Power Supply Cooling Fan
- Large or Small Fans

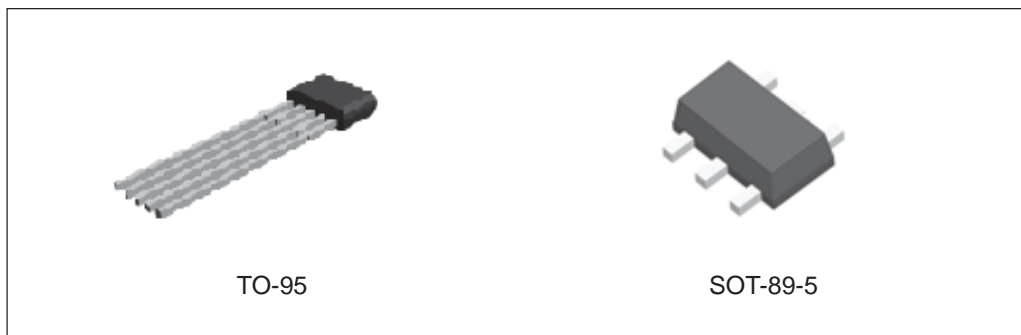

Figure 1. Package Types of AH9281/82

Two Phase Dual-coil High Voltage Smart Fan Motor Driver with FG/RD AH9281/82

Pin Configuration

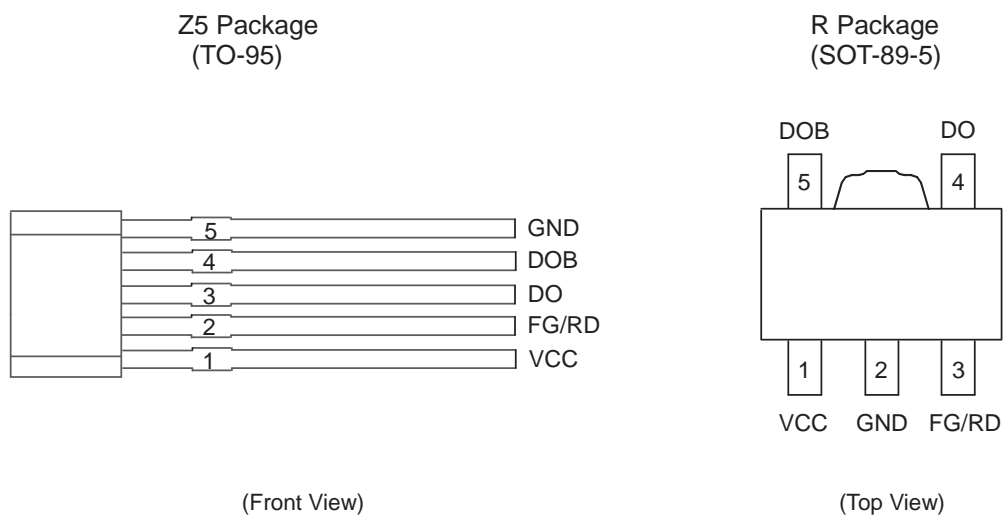

Figure 2. Pin Configuration of AH9281/82

Pin Description

Pin Number		Pin Name	Function
TO-95	SOT-89-5		
1	1	VCC	Power supply pin
2	3	FG/RD	Frequency Generator (Rotation Detection) open drain output
3	4	DO	Output pin 1
4	5	DOB	Output pin 2
5	2	GND	Ground pin

Two Phase Dual-coil High Voltage Smart Fan Motor Driver with FG/RD AH9281/82

Functional Block Diagram

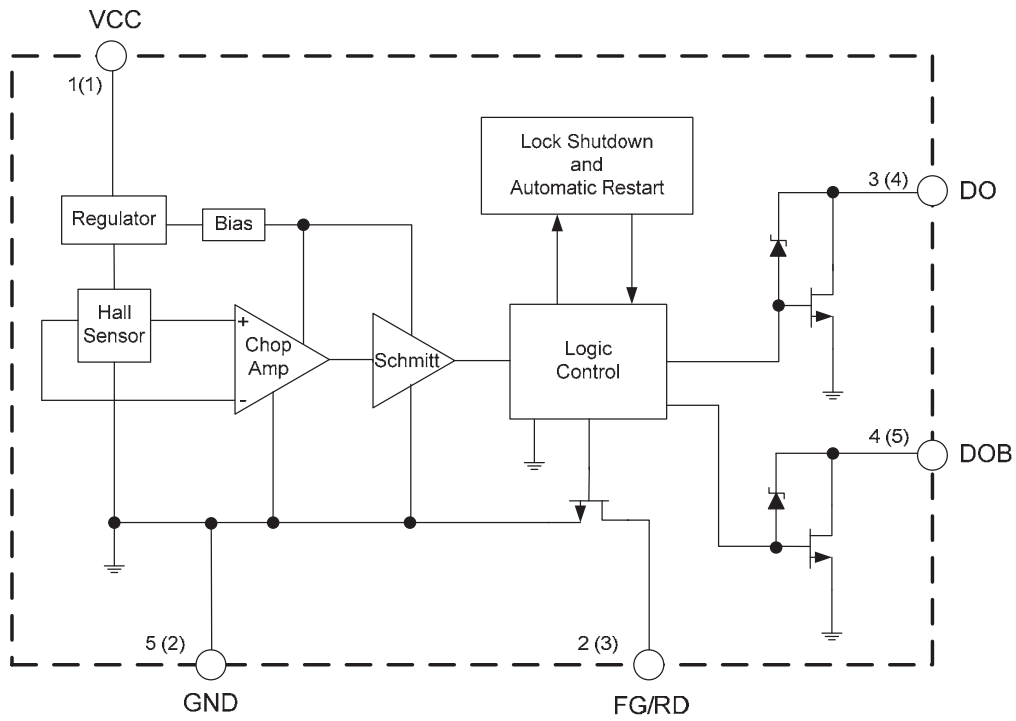

A (B)
A for TO-95
B for SOT-89-5

Figure 3. Functional Block Diagram of AH9281/82



Two Phase Dual-coil High Voltage Smart Fan Motor Driver with FG/RD AH9281/82

Ordering Information

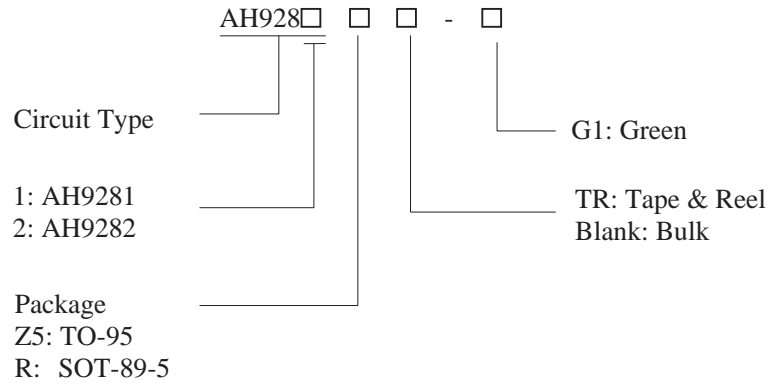

Package	Temperature Range	Output Signal	Part Number	Marking ID	Packing Type
TO-95	-40 to 125°C	FG	AH9281Z5-G1	9281Z5-G1	Bulk
		RD	AH9282Z5-G1	9282Z5-G1	Bulk
SOT-89-5		FG	AH9281RTR-G1	G41C	Tape & Reel
		RD	AH9282RTR-G1	G41D	Tape & Reel

BCD Semiconductor's Pb-free products, as designated with "G1" suffix in the part number, are RoHS compliant and green.

**Two Phase Dual-coil High Voltage Smart Fan Motor Driver with FG/RD AH9281/82****Absolute Maximum Ratings (Note 1, T_A=25°C)**

Parameter	Symbol	Value		Unit
Supply Voltage	V _{CC}	18		V
Supply Current (Fault)	I _{CC}	6		mA
Peak Output Current	I _{OUT_P}	1200		mA
Continuous Output Current	I _{OUT_C}	600		mA
FG/RD Pull-up Voltage	V _{FG} /V _{RD}	28		V
Power Dissipation	P _D	TO-95	600	mW
		SOT-89-5	800	
Thermal Resistance (Junction to Ambient)	θ _{JA}	TO-95	208	°C/W
		SOT-89-5	156	
Storage Temperature	T _{STG}	-55 to 150		°C
ESD (Human Body Model)	ESD	6000		V
ESD (Machine Model)	ESD	400		V

Note 1: Stresses greater than those listed under “Absolute Maximum Ratings” may cause permanent damage to the device. These are stress ratings only, and functional operation of the device at these or any other conditions beyond those indicated under “Recommended Operating Conditions” is not implied. Exposure to “Absolute Maximum Ratings” for extended periods may affect device reliability.

Recommended Operating Conditions

Parameter	Symbol	Min	Max	Unit
Supply Voltage	V _{CC}	2.5	16	V
Operating Ambient Temperature	T _A	-40	125	°C



Two Phase Dual-coil High Voltage Smart Fan Motor Driver with FG/RD AH9281/82

Electrical Characteristics

$V_{CC}=12V$, $T_A=25^{\circ}C$, unless otherwise specified.

Parameter	Symbol	Conditions	Min	Typ	Max	Unit
Supply Voltage	V_{CC}	Operating	2.5	12	16	V
Supply Current	I_{CC}	Average		4	6	mA
Output Current	I_{OUT}				500	mA
Output Leakage Current	$I_{LEAKAGE}$			0.1	10	μA
Saturation Voltage	V_{SAT}	$I_{OUT}=350mA$		600	1000	mV
Output ON Time	t_{ON}			0.8		S
Output OFF Time	t_{OFF}			5		S
FG/RD Output Low Voltage	V_{FGL}/V_{RDL}	$I_{FG}=5mA$		0.1	0.2	V
FG/RD Output Leakage Current	I_{FGLK}/I_{RDLEK}	$V_{FG}/V_{RD}=12V$		0.1	10	μA
FG/RD Output Current Limit	I_{FGLIM}/I_{RDLEK}	$V_{FG}/V_{RD}=12V$		30		mA
Output Zener Break-down Voltage	V_Z			35		V

Magnetic Characteristics

$V_{CC}=12V$, $T_A=25^{\circ}C$, unless otherwise specified.

Parameter	Symbol	Min	Typ	Max	Unit
Operating Point	B_{OP}	0	20	50	Gauss
Releasing Point	B_{RP}	-50	-20	0	Gauss
Hysteresis	B_{HYS}		40		Gauss

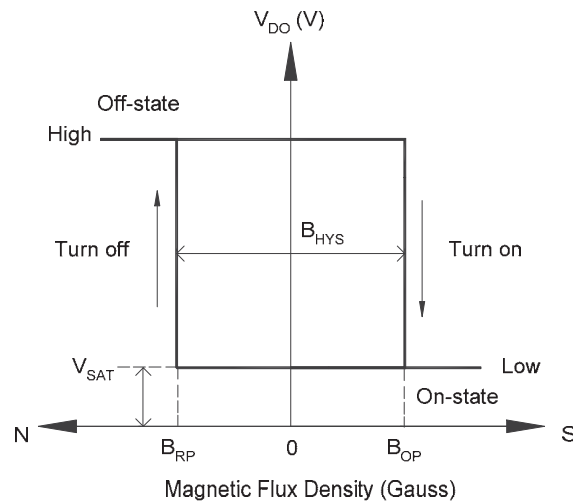

Two Phase Dual-coil High Voltage Smart Fan Motor Driver with FG/RD AH9281/82

Test Circuit

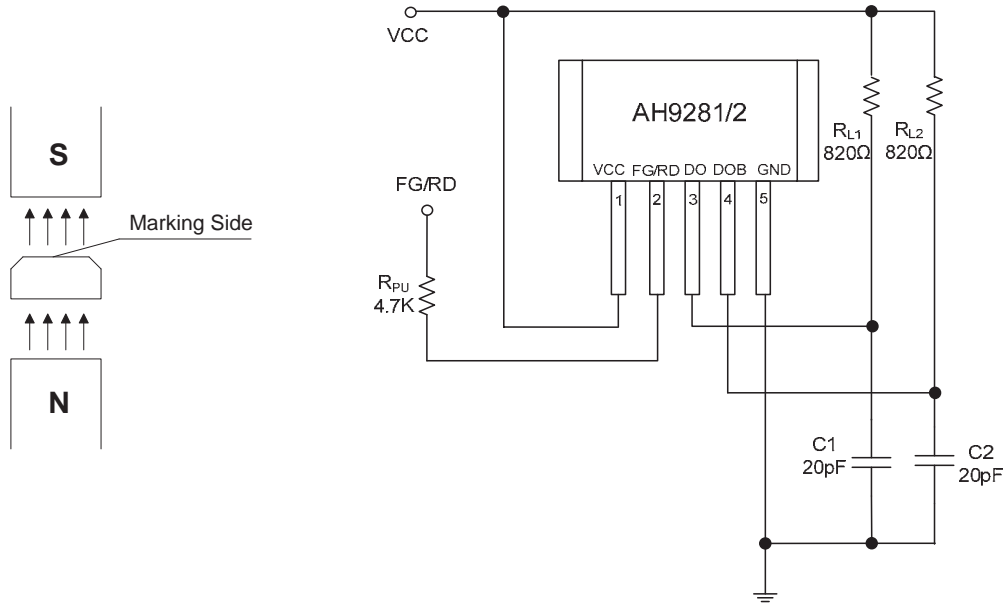

Figure 4. Basic Test Circuit of AH9281/82

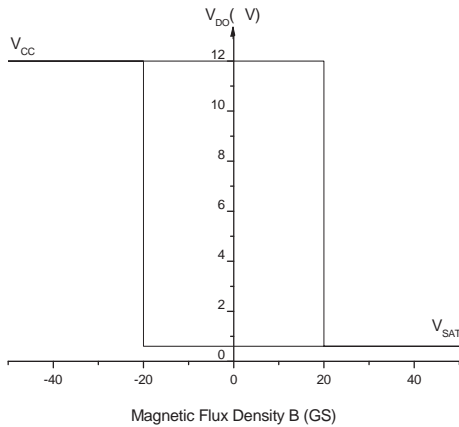

Figure 5. V_{DO} vs. Magnetic Flux Density

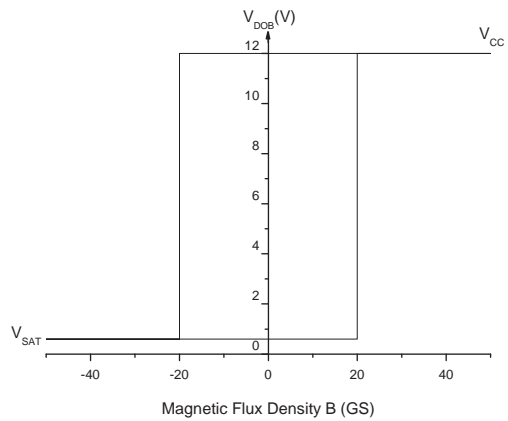

Figure 6. V_{DOB} vs. Magnetic Flux Density



Two Phase Dual-coil High Voltage Smart Fan Motor Driver with FG/RD AH9281/82

Typical Performance Characteristics

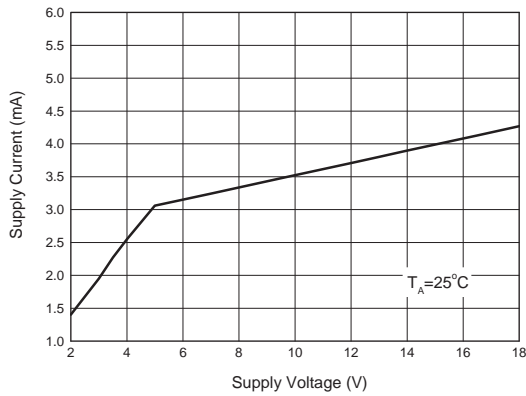

Figure 7. Supply Current vs. Supply Voltage

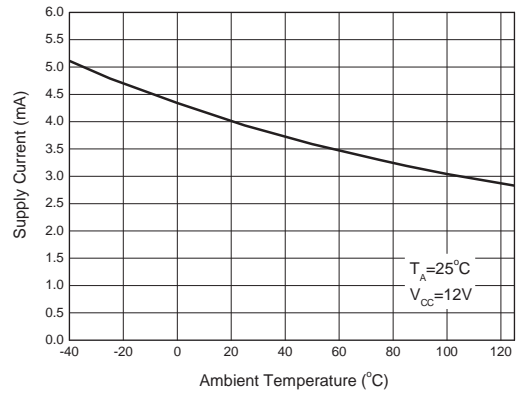

Figure 8. Supply Current vs. Ambient Temperature

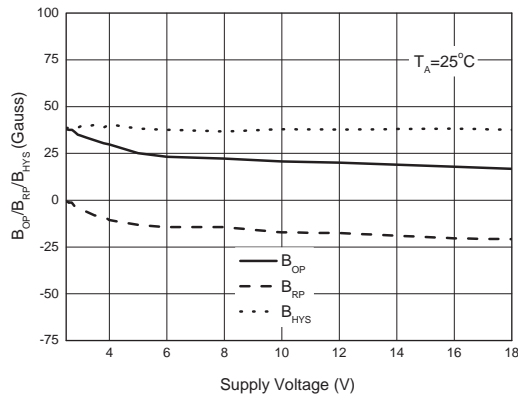

Figure 9. B_{OP}/B_{RP}/B_{HYS} vs. Supply Voltage

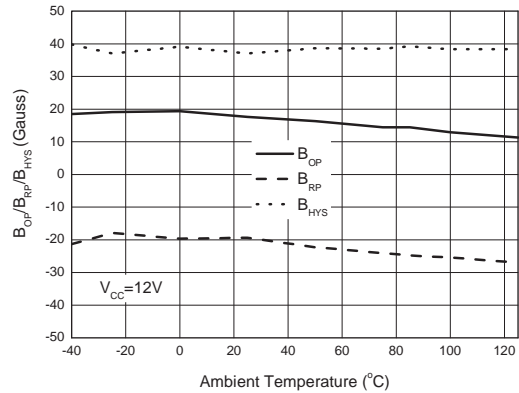

Figure 10. B_{OP}/B_{RP}/B_{HYS} vs. Ambient Temperature



Two Phase Dual-coil High Voltage Smart Fan Motor Driver with FG/RD AH9281/82

Typical Performance Characteristics (Continued)

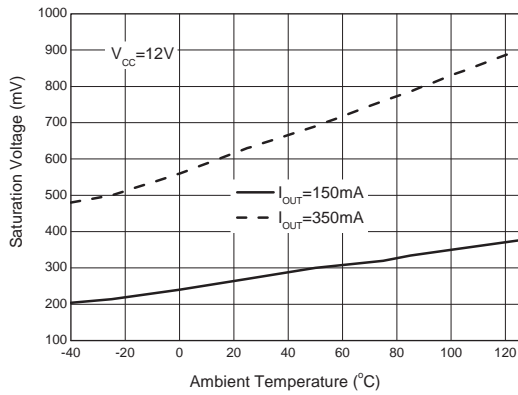

Figure 11. Saturation Voltage vs. Ambient Temperature

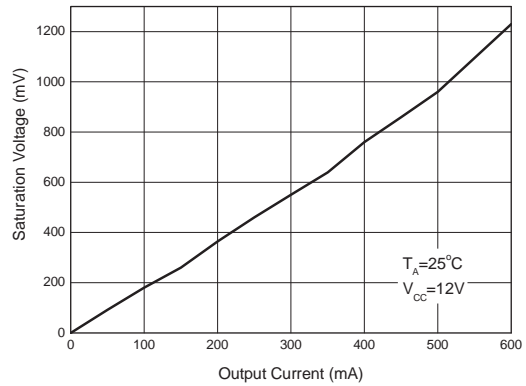

Figure 12. Saturation Voltage vs. Output Current

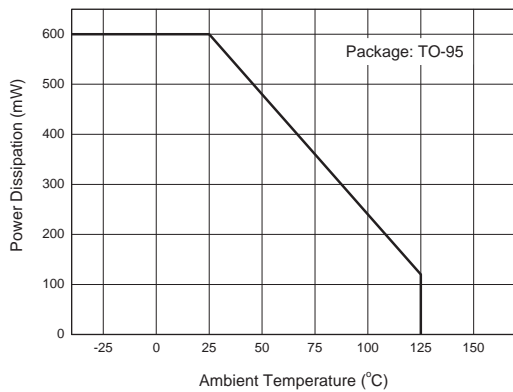

Figure 13. Power Dissipation vs. Ambient Temperature

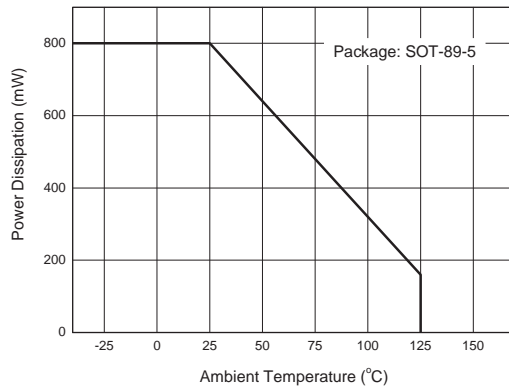

Figure 14. Power Dissipation vs. Ambient Temperature

Two Phase Dual-coil High Voltage Smart Fan Motor Driver with FG/RD AH9281/82
Typical Application

Figure 15. Typical Application 1 of AH9281/82 (TO-95, Note 2)

Note 2:

1. D1 is an ordinary diode used to filter the noise from VCC and protect IC if VCC and GND are plugged reversed.
2. R1=47Ω typical.
3. C1=C2=C3=2.2μF typical, electrolytic capacitors are better. They should be fine tuned based on system design.
4. R2=R3=4.7Ω typical. They can be cancelled according to system requirement.
5. R_{PU}=4.7kΩ typical.

Two Phase Dual-coil High Voltage Smart Fan Motor Driver with FG/RD AH9281/82
Typical Application (Continued)

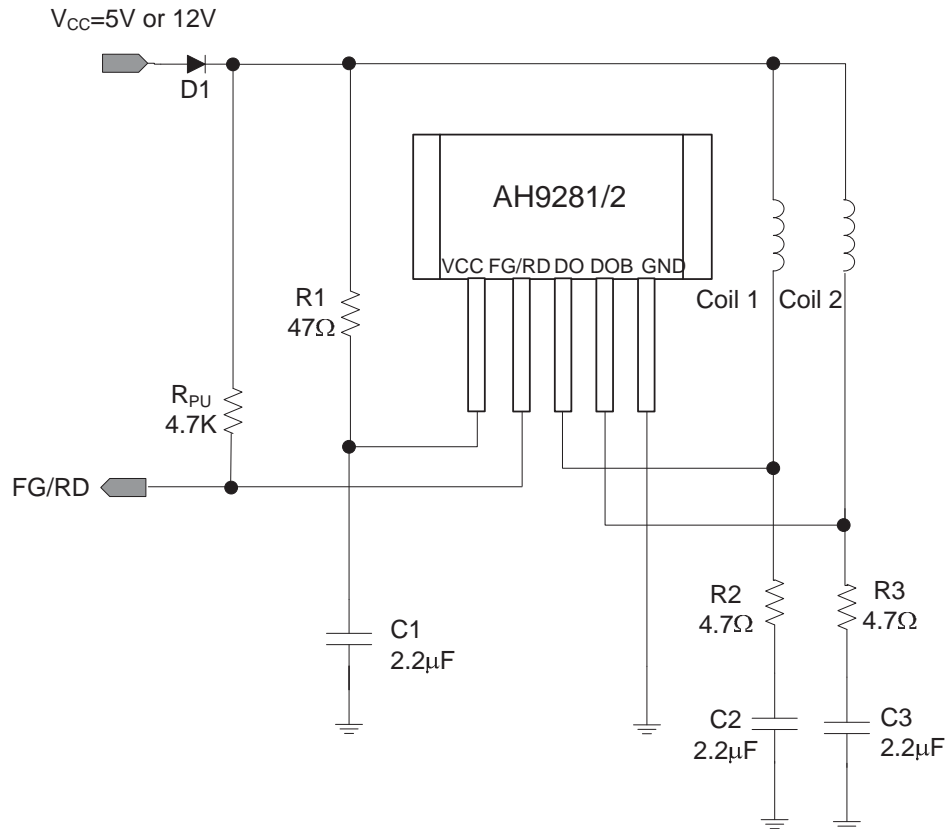
Figure 16. Typical Application 2 of AH9281/82 (TO-95, Note 3)

Note 3:

1. D1 is an ordinary diode used to filter the noise from VCC and protect IC if VCC and GND are plugged reversed.
2. R1=47Ω typical.
3. C1 =2.2μF typical, electrolytic capacitors are better. They should be fine tuned based on system design.
4. ZD1 and ZD2 breakdown voltage are 35V.
5. R_{PU}=4.7kΩ typical.

Two Phase Dual-coil High Voltage Smart Fan Motor Driver with FG/RD AH9281/82
Typical Application (Continued)

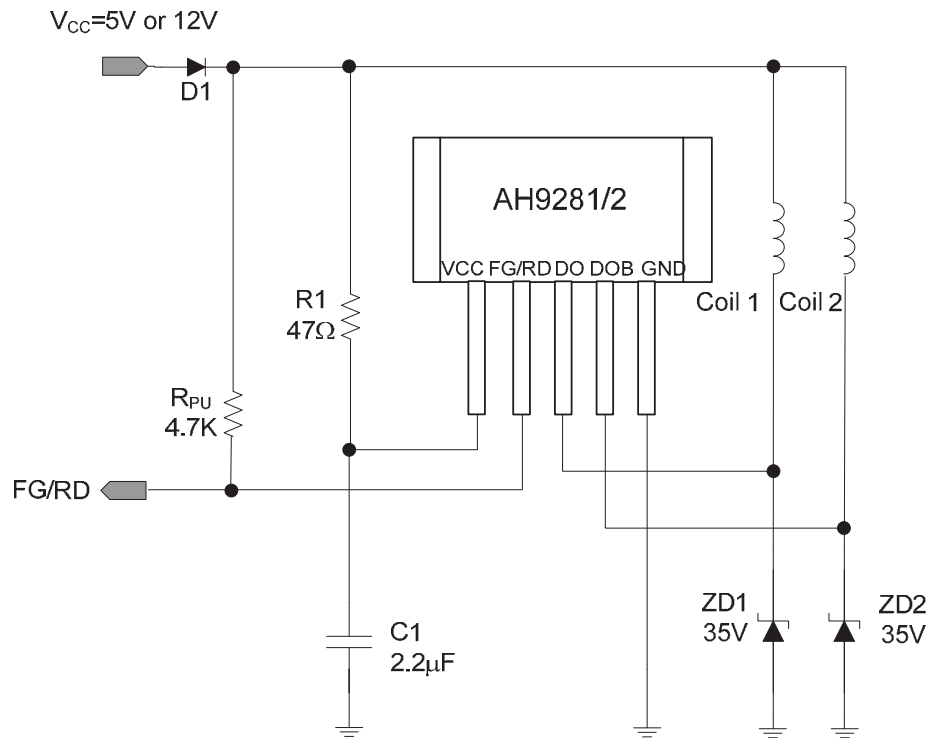
Figure 17. Typical Application 3 of AH9281/82 (SOT-89-5, Note 4)

Note 4:

1. D1 is an ordinary diode used to filter the noise from VCC and protect IC if VCC and GND are plugged reversed.
2. R1=47Ω typical.
3. C1=C2=C3=2.2μF typical, electrolytic capacitors are better. They should be fine tuned based on system design.
4. R2=R3=4.7Ω typical. They can be cancelled according to system requirement.
5. R_{PU}=4.7kΩ typical.

Two Phase Dual-coil High Voltage Smart Fan Motor Driver with FG/RD AH9281/82
Typical Application (Continued)

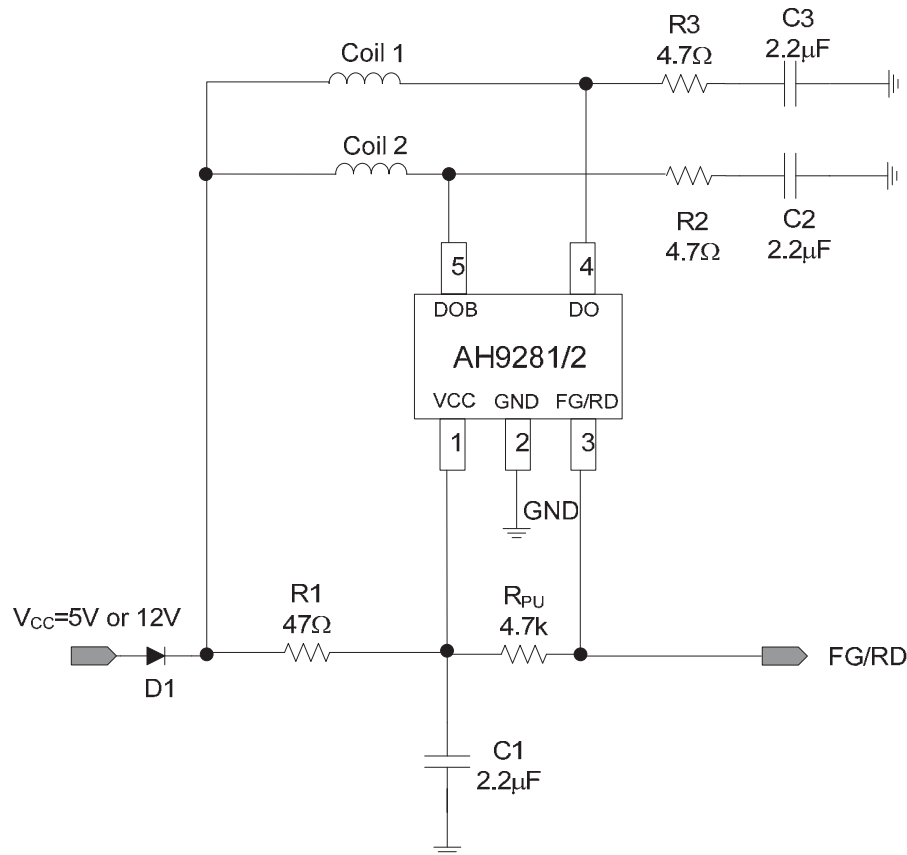
Figure 18. Typical Application 4 of AH9281/82 (SOT-89-5, Note 5)

Note 5:

1. D1 is an ordinary diode used to filter the noise from VCC and protect IC if VCC and GND are plugged reversed.
2. R1=47Ω typical.
3. C1=2.2μF typical, electrolytic capacitors are better. They should be fine tuned based on system design.
4. ZD1 and ZD2 breakdown voltage are 35V.
5. R_{PU}=4.7kΩ typical.

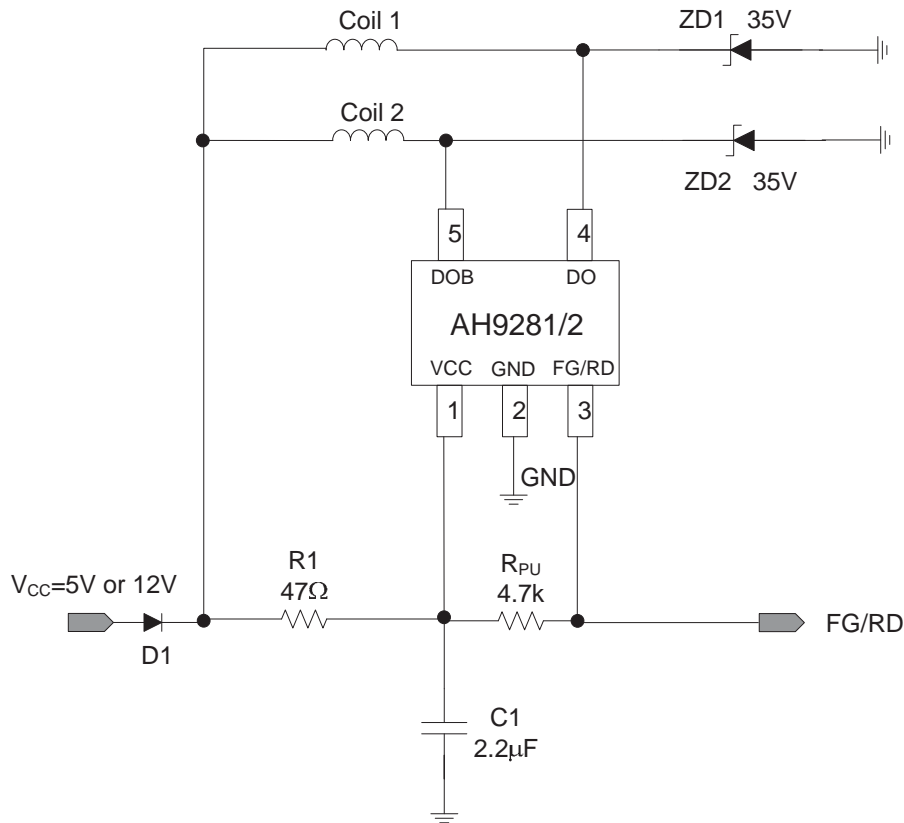

Two Phase Dual-coil High Voltage Smart Fan Motor Driver with FG/RD AH9281/82

Mechanical Dimensions

TO-95

Unit: mm(inch)

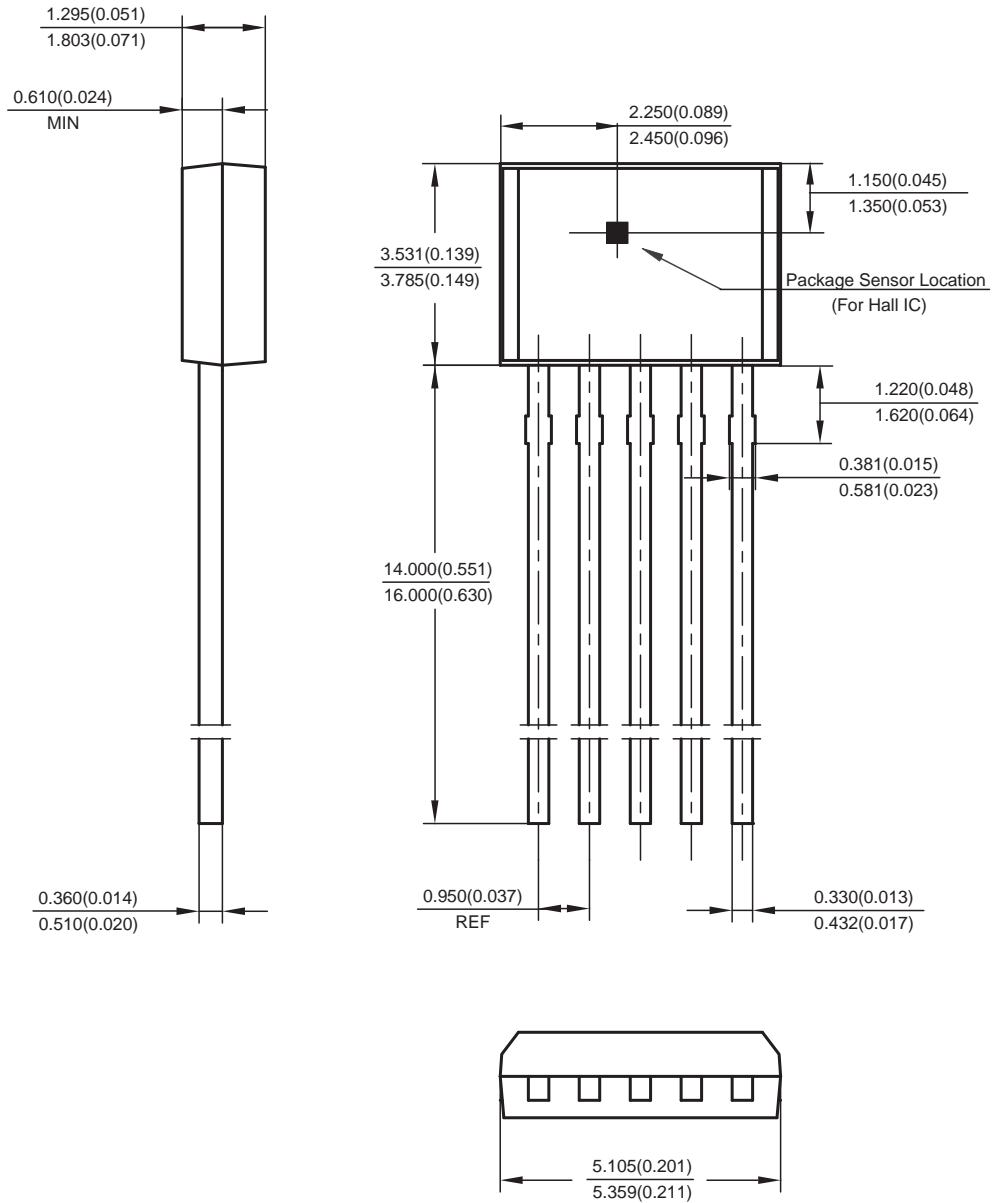



Two Phase Dual-coil High Voltage Smart Fan Motor Driver with FG/RD AH9281/82

Mechanical Dimensions (Continued)

SOT-89-5

Unit: mm(inch)

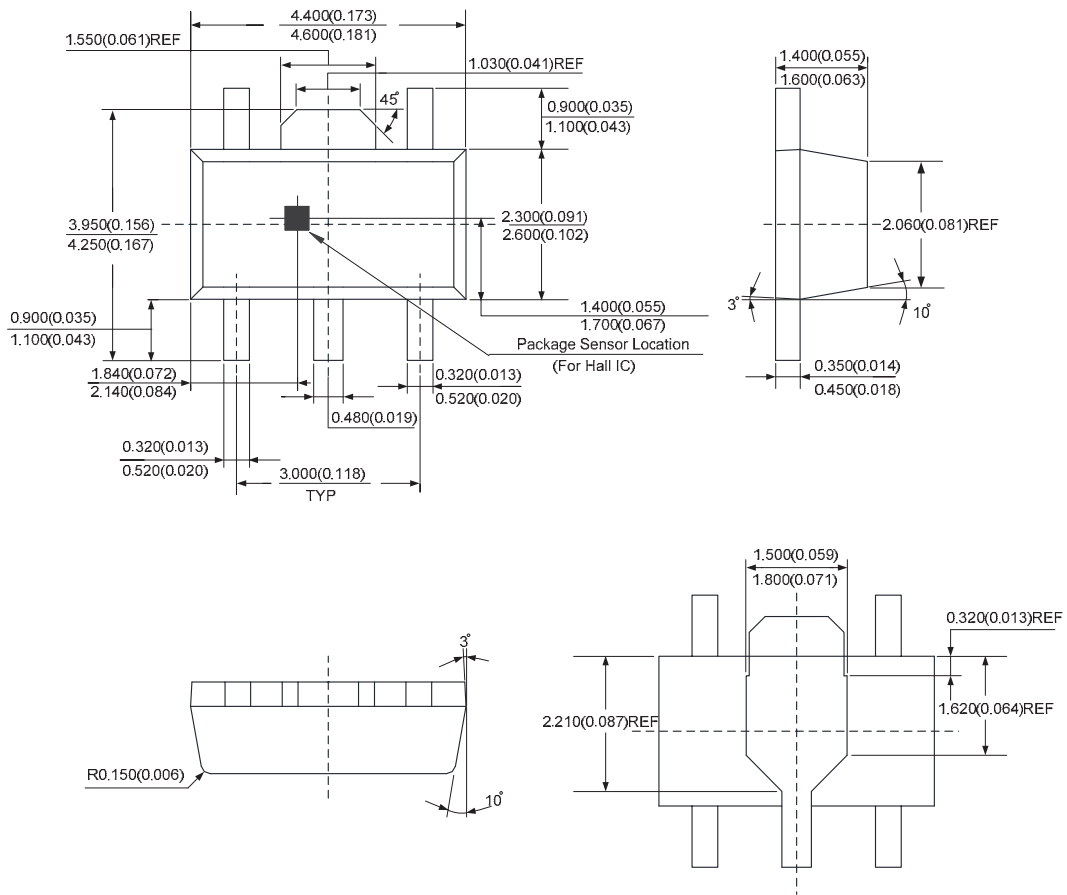

X-ON Electronics

Largest Supplier of Electrical and Electronic Components

Click to view similar products for [Board Mount Hall Effect/Magnetic Sensors](#) category:

Click to view products by [Diodes Incorporated](#) manufacturer:

Other Similar products are found below :

[ACHS-7194-500E](#) [ACHS-7193-500E](#) [ACHS-7193-000E](#) [ACHS-7194-000E](#) [G-MRCO-017](#) [A1104LUA-T](#) [A1212LUA-T](#) [HGPRDT005A](#)
[AH1808-P-A](#) [AH277AZ4-AG1](#) [AH373-WG-7](#) [AV-10379](#) [AV-10448](#) [A1211LUA-T](#) [SS41C](#) [AH1803-WG-7](#) [AH1806-P-B](#) [AH1894-Z-7](#)
[MA700GQ-P](#) [ATS601LSGTN-HT-WU4-T](#) [ATS601LSGTN-LT-WU4-T](#) [TLE4917](#) [TLE4946-1L](#) [50017859-003](#) [TY-13101](#) [TLE4976L](#)
[AH1751-WG-7-A](#) [SS85CA](#) [BU52002GUL-E2](#) [MAX13366GTE/V+](#) [A1128LUA-T](#) [AH173-WG-7-B](#) [MA702GQ-P](#) [BU52003GUL-E2](#)
[AH277AZ4-BG1](#) [TLE49614MXTSA1](#) [AH3376-P-B](#) [TLE4941](#) [AH3382-P-B](#) [AH3372-W-7](#) [AH9250-W-7](#) [AH211Z4-AG1](#) [AH9251-W-7](#)
[TLE4905L](#) [AH3373-W-7](#) [AH3377-W-7](#) [AH3360-FT4-7](#) [AH3376-W-7](#) [TLE4961-3M](#) [AS5601-ASOT](#)