

## Description

The AL1665 is a high performance single stage flyback and buck-boost controller, targeting dimmable LED lighting application. It is a Primary Side Regulation (PSR) controller which can provide accurate Constant Current (CC) regulation without opto-coupler and secondary control circuitry. It can be operated at BCM mode which results in low EMI and high efficiency, and keeps high Power Factor (PF) and low Total Harmonic Distortion (THD) under universal input voltage.

The AL1665 can support analog/PWM dimming modes. When a 50mV to 2.5V DC signal is applied on ADIM pin, the device will be operated in analog dimming mode. The analog dimming range is 5% to 100%. When a PWM signal is applied to NTC/PWM pin, the device will be operated at PWM dimming mode. The PWM dimming range is 0.5% to 100% (1k PWM dimming frequency).

The AL1665 features low operation current. It integrates multiple protections including over voltage, short circuit, over current and over temperature.

The AL1665 is available in SO-8 (Standard) package.

## Features

- Primary Side Regulation without Opto-Coupler
- Valley Switching for Low Switching Loss
- Low Start-Up Current
- Support Analog and PWM Dimming
  - Analog Dimming Range: 5% to 100%
  - PWM Dimming Range: 0.5% to 100% (1k PWM Frequency)
- Internal Protections
  - Under Voltage Lock Out (UVLO)
  - Output Over Voltage Protection (OVP)
  - Output Short Protection (OSP)
  - Over Current Protection (OCP)
  - CS Short Protection
  - Winding Short Circuit Protection
  - Secondary Diode Short Protection
  - Shorted Current Sense Protection
  - User Programmable NTC Based Thermal Foldback
  - Internal Thermal Fold-Back Protection (TFP)
  - Over Temperature Protection (OTP)
- Low System Cost
- High PF>0.9 and Low THD<20%
- High Efficiency
- Tight LED Current Variation Range
  - LED Current Line Regulation:  $\pm 2\%$
  - LED Current Load Regulation:  $\pm 2\%$  Full Load to Half Load
- Tight Output Open Voltage Variation Range
- Package: SO-8 (Standard)
- **Totally Lead-Free & Fully RoHS Compliant (Notes 1 & 2)**
- **Halogen and Antimony Free. "Green" Device (Note 3)**

Notes: 1. No purposely added lead. Fully EU Directive 2002/95/EC (RoHS), 2011/65/EU (RoHS 2) & 2015/863/EU (RoHS 3) compliant.  
 2. See <https://www.diodes.com/quality/lead-free/> for more information about Diodes Incorporated's definitions of Halogen- and Antimony-free, "Green" and Lead-free.  
 3. Halogen- and Antimony-free "Green" products are defined as those which contain <900ppm bromine, <900ppm chlorine (<1500ppm total Br + Cl) and <1000ppm antimony compounds.

## Pin Assignments

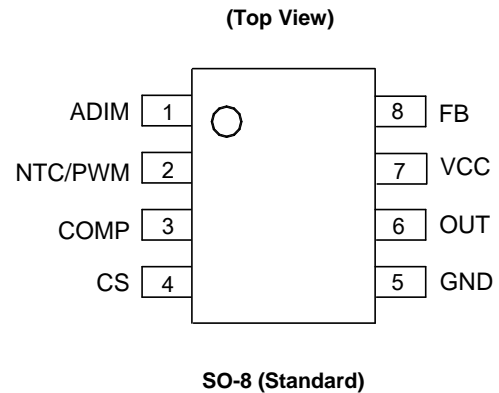

## Applications

- General LED Lighting Driver with Dimming Function
- General Purpose Constant Current Source
- LED Backlighting Driver
- Smart LED Lighting

Typical Applications Circuit

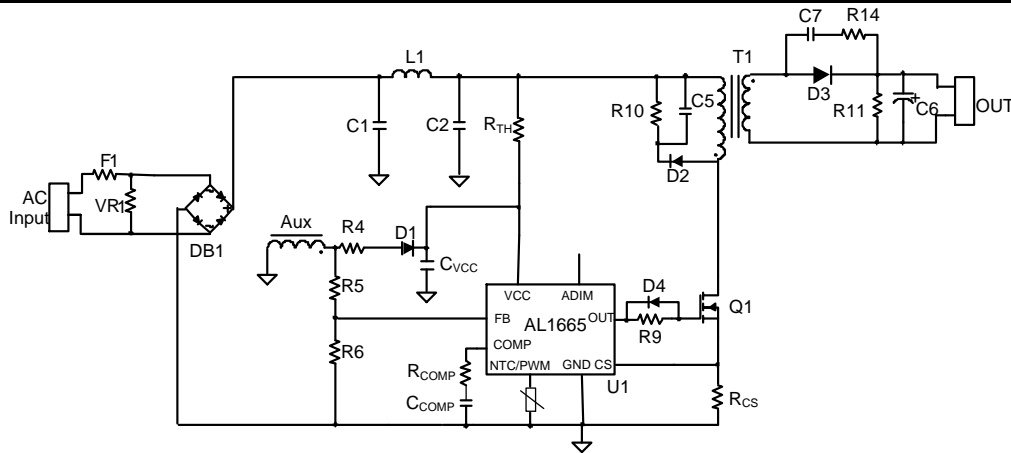

Flyback Application Circuit

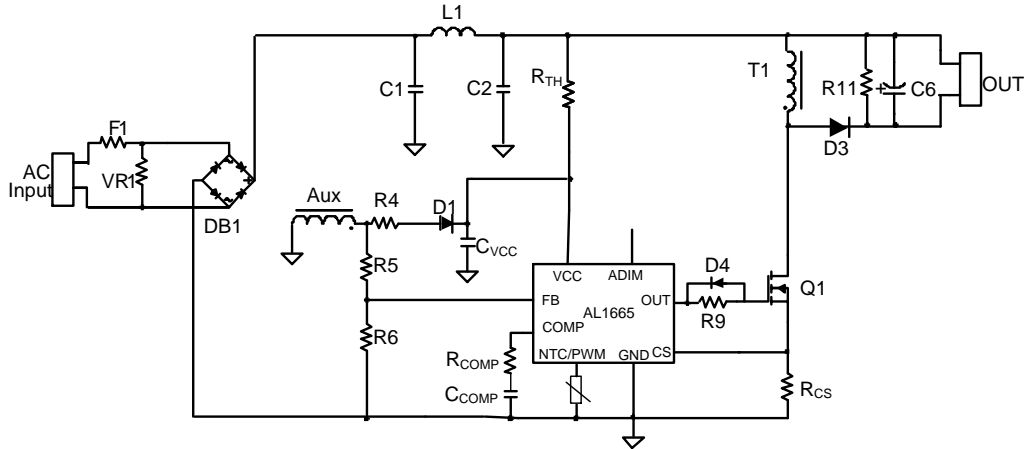

Buck-Boost Application Circuit

Pin Descriptions

Pin Number	Pin Name	Function
1	ADIM	Analog Dimming Input Pin
2	NTC/PWM	NTC Input Pin for Thermal Foldback/PWM Dimming Input Pin
3	COMP	Loop Compensation Pin
4	CS	Current Sense Pin, Connect This Pin to the Source of the Primary Switch
5	GND	Ground
6	OUT	Gate Driver Output
7	VCC	Supply Voltage of Gate Driver and Control Circuits of the IC
8	FB	The Feedback Voltage Sensing from the Auxiliary Winding

NEW PRODUCT

**Functional Block Diagram**

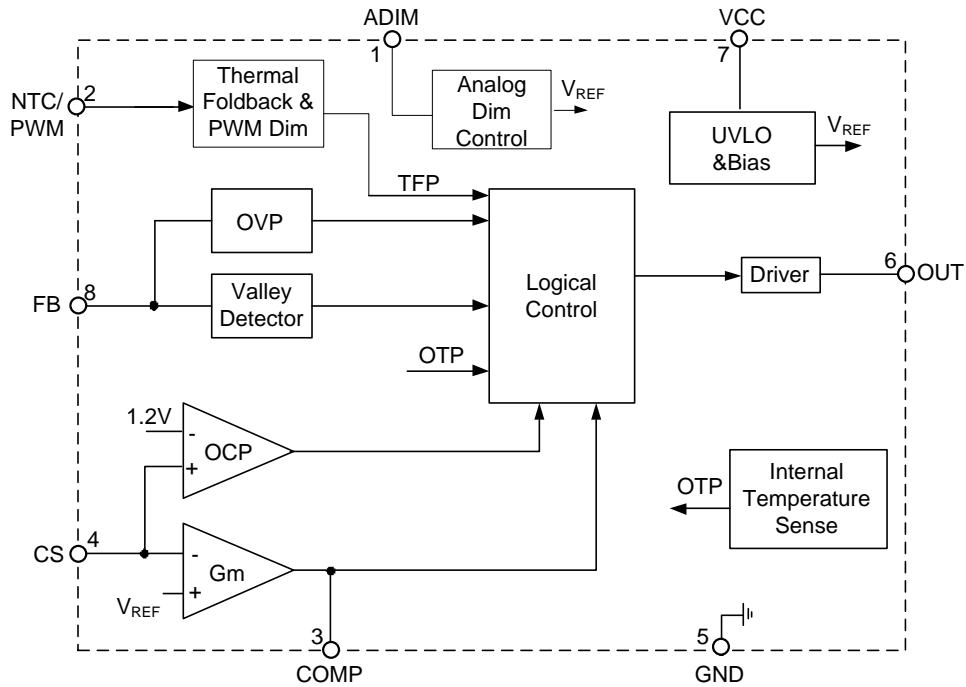

**Absolute Maximum Ratings** (@T<sub>A</sub> = +25°C, unless otherwise specified.) (Note 4)

Symbol	Parameter	Rating	Unit
V <sub>CC</sub>	Power Supply Voltage	-0.3 to 30	V
V <sub>CS</sub>	Voltage at CS to GND	-0.3 to 7	V
V <sub>FB</sub>	FB Input Voltage	-0.3 to 7	V
V <sub>COMP</sub>	Voltage at Loop Compensation Pin	-0.3 to 7	V
V <sub>OUT</sub>	Driver Output Voltage	-0.3 to 20	V
V <sub>NTC/PWM</sub>	Voltage at NTC/PWM to GND	-0.3 to 7	V
V <sub>ADIM</sub>	Voltage at ADIM to GND	-0.3 to 7	V
T <sub>J</sub>	Operating Junction Temperature	-40 to +150	°C
T <sub>STG</sub>	Storage Temperature	-65 to +150	°C
T <sub>LEAD</sub>	Lead Temperature (Soldering, 10s)	+300	°C
P <sub>D</sub>	Power Dissipation at T <sub>A</sub> = +50°C	0.65	W
θ <sub>JA</sub>	Thermal Resistance (Junction to Ambient)	136	°C/W
θ <sub>JC</sub>	Thermal Resistance (Junction to Case)	30	°C/W
-	ESD (Human Body Model)	2000	V
	ESD (Charged-Device Model)	1000	V

Note: 4. Stresses greater than those listed under *Absolute Maximum Ratings* can cause permanent damage to the device. These are stress ratings only, and functional operation of the device at these or any other conditions beyond those indicated under *Recommended Operating Conditions* is not implied. Exposure to *Absolute Maximum Ratings* for extended periods can affect device reliability. All voltages unless otherwise stated are measured with respect to GND.

**Recommended Operating Conditions** (@T<sub>A</sub> = +25°C, unless otherwise specified.)

Symbol	Parameter	Min	Max	Unit
T <sub>A</sub>	Ambient Temperature (Note 5)	-40	+105	°C
V <sub>CC</sub>	Operating VCC Voltage (Note 6)	8.5	V <sub>CC_OVP</sub> (Min)	V

- Notes:
- The device may operate normally at +125°C ambient temperature under the condition not triggers temperature protection.
  - I<sub>CC</sub> should be limited less than 5mA.

**Electrical Characteristics** (@T<sub>A</sub> = +25°C, unless otherwise specified.)

Symbol	Parameter	Conditions	Min	Typ	Max	Unit
<b>UVLO Section</b>						
V <sub>CC_TH</sub>	Startup Threshold Voltage	–	15.8	18.5	19.5	V
V <sub>OPR_MIN</sub>	Minimal Operating Voltage	After Turn On	5.8	7.8	9	V
V <sub>CC_OVP</sub>	V <sub>CC</sub> OVP Voltage	–	21.8	25	29.5	V
<b>Standby Current Section</b>						
I <sub>ST</sub>	Startup Current	V <sub>CC</sub> = V <sub>CC_TH</sub> -0.5V, Before Start Up	–	120	300	μA
I <sub>CC</sub>	Operating Current	FB, CS Connect to GND, C <sub>GATE</sub> = 100pF	–	2	4	mA
I <sub>CC_OVP</sub>	Shunt Current in OVP Mode	V <sub>CC</sub> > V <sub>CC_OVP</sub>	3.1	–	–	mA
<b>Drive Output Section</b>						
t <sub>R</sub>	Output Voltage Rise Time (Note 7)	C <sub>L</sub> = 1nF	–	100	–	ns
t <sub>F</sub>	Output Voltage Fall Time (Note 7)	C <sub>L</sub> = 1nF	–	100	–	ns
V <sub>OUT_CLAMP</sub>	Output Clamp Voltage	V <sub>CC</sub> = 20V	9.8	12	15.5	V
t <sub>ON_MIN</sub>	Minimum On Time (Note 7)	–	–	1000	2010	ns
t <sub>ON_MAX</sub>	Maximum On Time	–	–	20	31	μs
t <sub>OFF_MAX</sub>	Maximum Off Time	–	–	290	405	μs
f <sub>MAX</sub>	Maximum Frequency	–	–	150	–	kHz
<b>Internal CS Reference</b>						
V <sub>REF</sub>	Internal Reference Voltage	–	0.394	0.4	0.406	V
V <sub>CS_CLAMP</sub>	Primary Current Clamp Voltage	–	1.8	2	2.5	V
V <sub>CS_OCP</sub>	Primary Over Current Voltage	–	–	3	–	V
<b>Error Amplifier</b>						
G <sub>m</sub>	Trans-Conductance	–	–	27	–	μA/V
I <sub>SOURCE</sub>	Amplifier Source Current	–	–	7.2	–	μA
<b>Feedback Input Section</b>						
V <sub>FB_CV</sub>	FB CV Threshold	–	2.5	3.0	3.5	V
<b>ADIM Section</b>						
–	Analog Dimming Range on ADIM	–	0.05	–	2.5	V
–	Analog Dimming High Level	–	2.45	2.5	2.55	V
–	Analog Dimming Range Ratio	–	5%	–	100%	–

Note: 7. These parameters, although guaranteed by design, are not 100% tested in production.

### Electrical Characteristics (@T<sub>A</sub> = +25°C, unless otherwise specified.) (continued)

Symbol	Parameter	Conditions	Min	Typ	Max	Unit
<b>NTC/PWM Section</b>						
V <sub>NTC/PWM(PULL-UP)</sub>	Pull-Up Voltage when NTC/PWM Open	NTC/PWM Pin Open	–	2.5	–	V
I <sub>OTP(REF)</sub>	Reference Current for Direct Connection of NTC/PWM (Note 9)	–	70.5	85	91	μA
V <sub>OTP(OFF)</sub>	Fault Detection Level for OTP (Note 8)	V <sub>NTC/PWM</sub> Falling	–	0.50	–	V
V <sub>OTP(ON)</sub>	NTC/PWM Pin Level for Operation Recovery after an OTP Detection	V <sub>NTC/PWM</sub> Rising	–	0.70	–	V
t <sub>OTP(START)</sub>	OTP Blanking Time when Circuit Starts Operating (Note 9)	–	250	–	370	μs
V <sub>TF(START)</sub>	NTC/PWM Pin Voltage at which Thermal Fold-Back Starts (V <sub>REF</sub> is Decreased)	–	0.94	1.00	1.06	V
V <sub>TF(STOP)</sub>	NTC/PWM Pin Voltage at which Thermal Fold-Back Stops (V <sub>REF</sub> is Clamped to V <sub>REF50</sub> )	–	0.64	0.69	0.74	V
V <sub>REF(50)</sub>	V <sub>REF</sub> @ V <sub>NTC/PWM</sub> = 600mV (Percent of V <sub>REF</sub> )	–	40	50	60	%
<b>Thermal Fold-Back Section</b>						
T <sub>REG</sub>	Overheating Temperature Regulation (Note 7)	–	–	+150	–	°C
<b>Over Temperature Protection Section</b>						
–	Shutdown Temperature (Notes 7, 8)	–	–	+180	–	°C

- Notes:
7. These parameters, although guaranteed by design, are not 100% tested in production.
  8. The device will latch when OTP happens and won't be operated constantly at this temperature.
  9. At startup, when V<sub>CC</sub> reaches V<sub>CC(ON)</sub>, the controller blanks OTP for more than 250μs to avoid detecting an OTP fault by allowing the NTC/PWM pin voltage to reach its nominal value if a filtering capacitor is connected to the NTC/PWM pin.

NEW PRODUCT

**Performance Characteristics** (Note 10)

NEW PRODUCT

**Startup Threshold Voltage vs. Ambient Temperature**

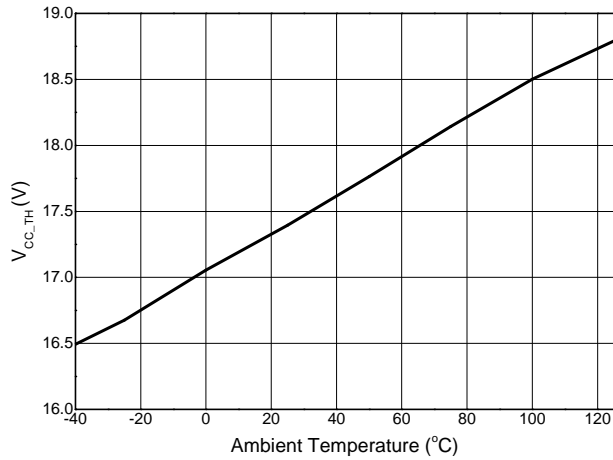

**Minimum Operating Voltage vs. Ambient Temperature**

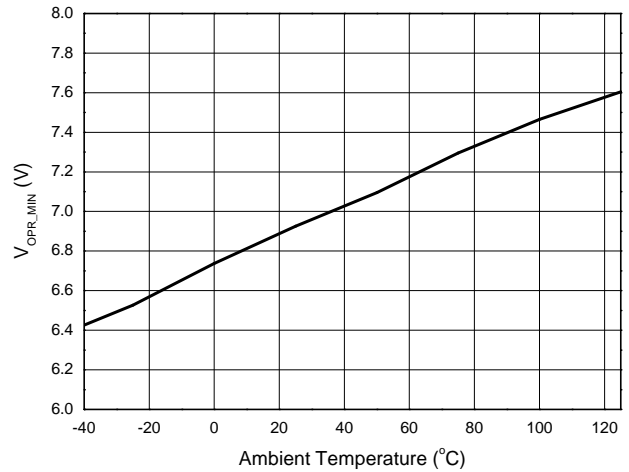

**V<sub>CC</sub> OVP Voltage vs. Ambient Temperature**

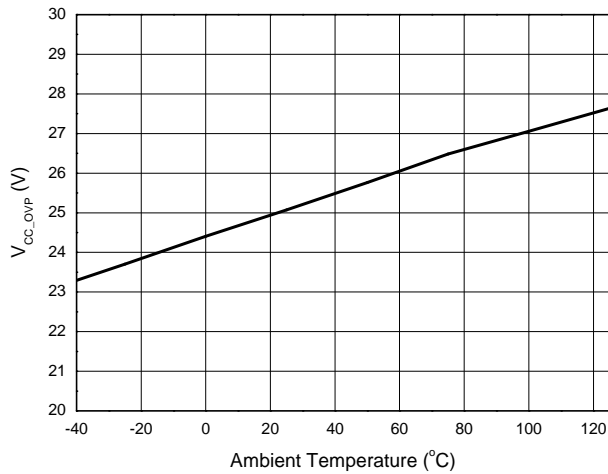

**Startup Current vs. Ambient Temperature**

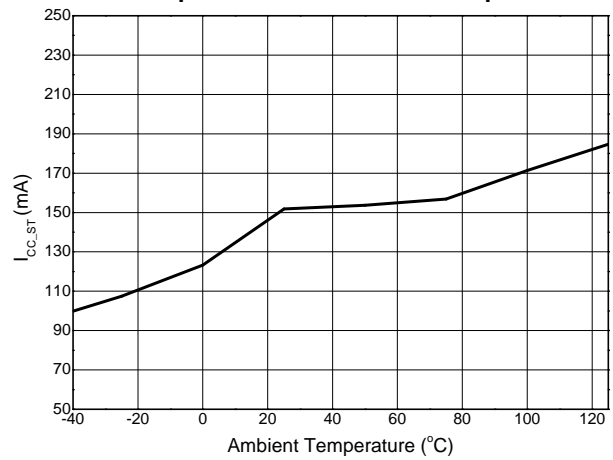

**Operating Current vs. Ambient Temperature**

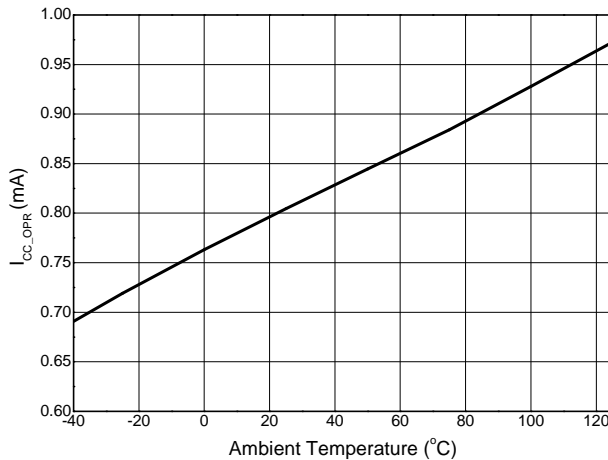

**CS Reference Voltage vs. Ambient Temperature**

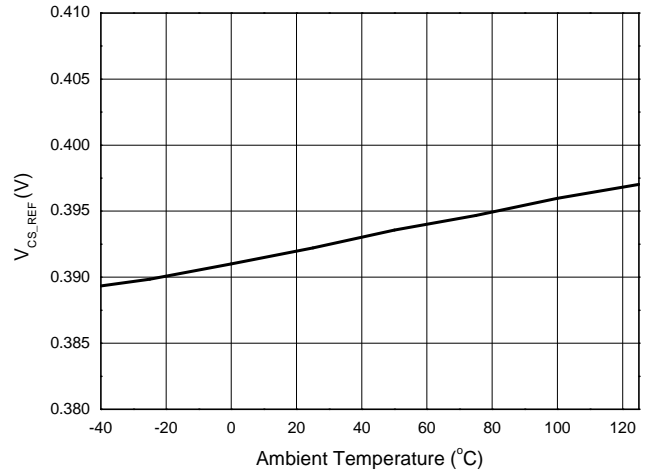

Note: 10. These electrical characteristics are tested under DC condition. The ambient temperature is equal to the junction temperature of the device.

**Performance Characteristics** (continued)

NEW PRODUCT

**CS Clamp Reference Voltage vs. Ambient Temperature**

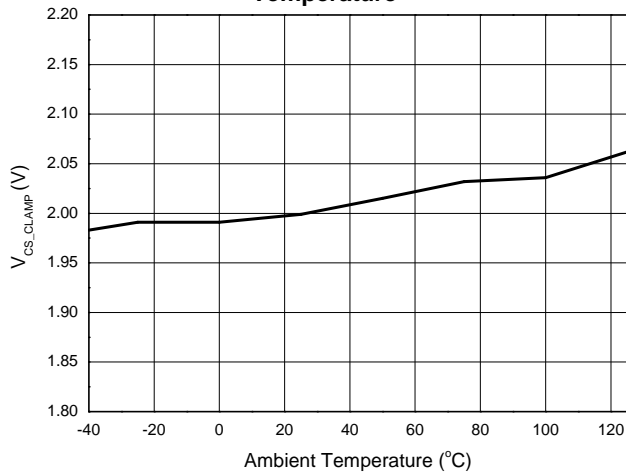

**FB CV Threshold vs. Ambient Temperature**

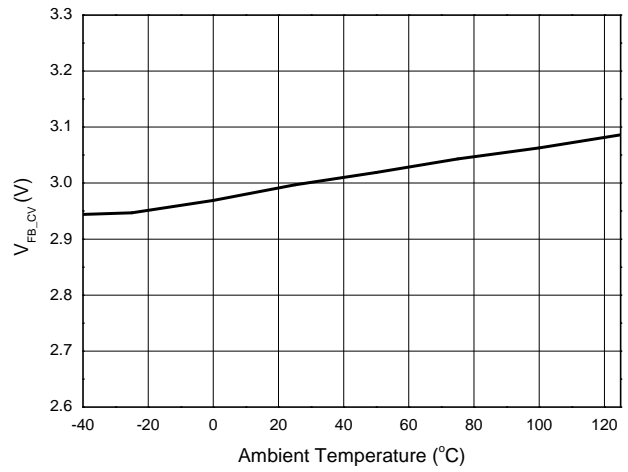

**FB CV Threshold vs.  $V_{CC}$  Voltage**

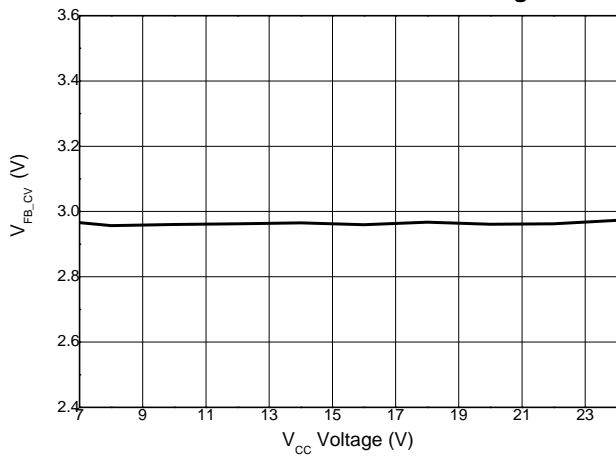

**CS Reference Voltage vs.  $V_{CC}$  Voltage**

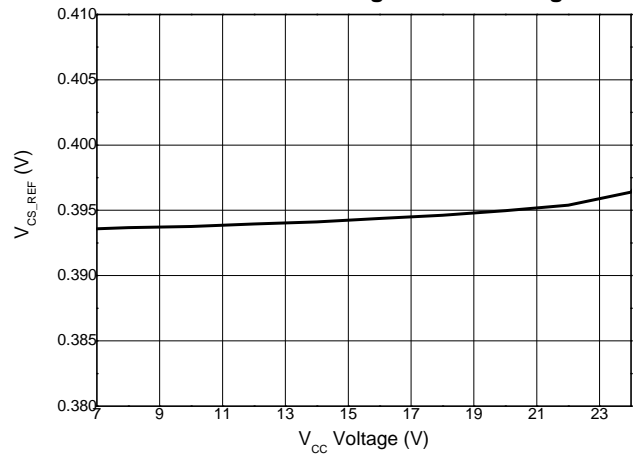

**PWM Dimming Curve**

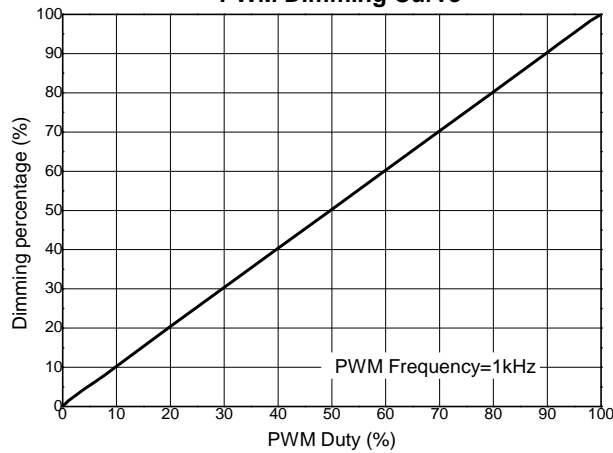

**Analog Dimming Curve**

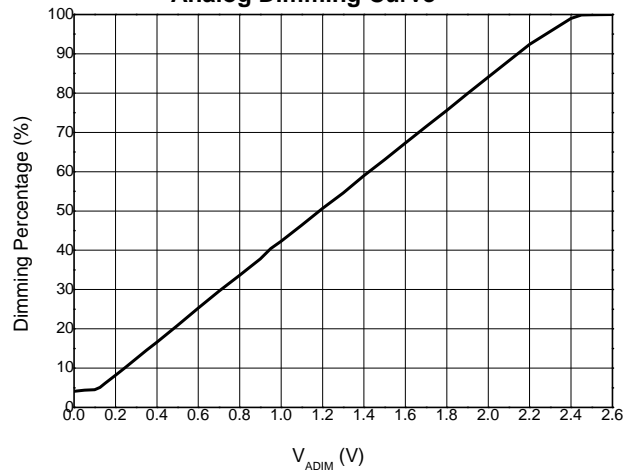

## Application Information

The AL1665 is a constant current high PF flyback and buck-boost controller with Primary Side Regulation (PSR), targeting LED lighting applications. The device eliminates the opto-couplers or the secondary feedback circuits, which is helpful to cost down the whole system. High power factor is achieved by constant on-time operation. In order to reduce the switching losses and improve EMI performance, quasi-resonant switching mode is applied. The AL1665 integrates multiple protections including UVLO protection,  $V_{CC}$  over voltage protection, output open voltage protection, over current protection, thermal fold-back protection and over temperature protection. The AL1665 can support analog and PWM dimming modes.

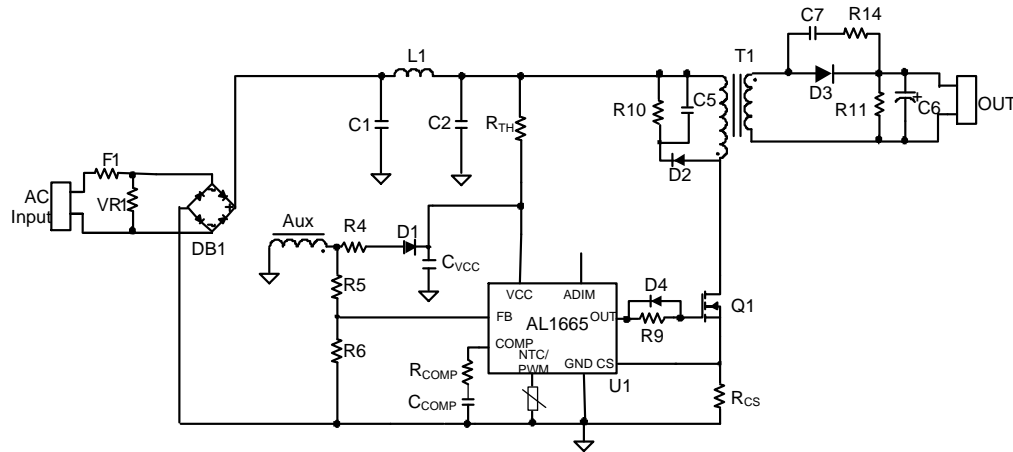

Figure 1. Flyback Application Circuit

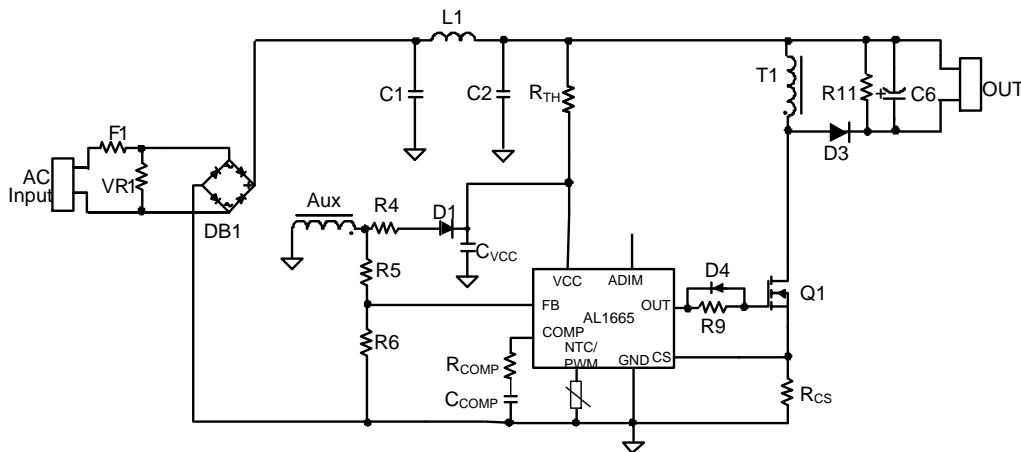

Figure 2. Buck-Boost Application Circuit

### Start-Up

After AC supply is powered on, the capacitor  $C_{VCC}$  across VCC and GND pin will be charged up by BUS voltage through a start-up resistor  $R_{TH}$ . Once  $V_{CC}$  reaches  $V_{CC\_TH}$ , the internal blocks start to work.  $V_{CC}$  will be supplied by  $V_{BUS}$  until the auxiliary winding of flyback transformer could supply enough energy to maintain  $V_{CC}$  above  $V_{OPR\_MIN}$ . If  $V_{CC}$  voltage is lower than  $V_{OPR\_MIN}$ , switch will be turned off.

After  $V_{CC}$  exceeds  $V_{CC\_TH}$ , the drive blocks won't start to switch on/off signals until  $V_{COMP}$  is higher than the initial voltage  $V_{COMP\_ST}$ , which can be programmed by  $R_{COMP}$ . The formula is shown as below. Such design can program startup on time to reduce the startup time or the output overshoot current.

$$V_{COMP\_ST} = 1.4V - 700\mu A \cdot R_{COMP}$$

Where  $V_{COMP\_ST}$  is the pre-charged voltage of COMP pin.  $R_{COMP}$  is shown as Figure 1.

Generally, a big capacitance of  $C_{COMP}$  is necessary to achieve high power factor and stabilize the system loop (1 $\mu$ F to 2 $\mu$ F is recommended). The pre-charged voltage in start-up procedure can be programmed by  $R_{COMP}$ .



## Application Information (continued)

### Protections

#### 1. Output Open Protection (OVP)

The output voltage is reflected by the voltage on transformer's auxiliary winding. Both the FB pin and the VCC pin of IC have the over voltage protection function. When there is a rapid line and load transient, the output voltage may exceed the regulated value. If  $V_{CC}$  exceeds  $V_{CC\_OVP}$ , the  $V_{CC}$  over voltage protection will be triggered, the switch will be turned off and the  $V_{CC}$  will be discharged. Once  $V_{CC}$  is lower than  $V_{OPR\_MIN}$ , the IC will shut down and be powered on again by BUS voltage through start up resistor. If  $V_{FB}$  exceeds  $V_{FB\_CV}$ , the FB over voltage protection will be triggered, switch will be turned off and  $V_{CC}$  will be latched for 16s, then  $V_{CC}$  will be discharged. Once  $V_{CC}$  is below  $V_{OPR\_MIN}$ , the IC will shut down and be powered on again by BUS voltage through start up resistor. Power dissipation is low when FB over voltage protection happens. Thus, output over voltage depends on the minimum voltage between both OVP protections' limitation. It can be gotten by below formula.

$$V_{OVP} = \text{Min} \left( \frac{N_S}{N_{AUX}} \cdot V_{CC\_OVP}, \frac{N_S}{N_{AUX}} \cdot \frac{R5 + R6}{R6} \cdot V_{FB\_CV} \right)$$

Where  $V_{OVP}$  is the output over voltage setting; R5 and R6 shown in Figure 1 are divider resistors connected from the auxiliary winding.  $N_{AUX}$  is the turns of auxiliary wind;  $N_S$  is turns of the secondary wind.  $V_{CC\_OVP}$  is the OVP Voltage of  $V_{CC}$ .

#### 2. Output Short Protection (OSP)

When the output is shorted, the output voltage would drop down to zero. The output voltage of the auxiliary winding, which is proportional to the output winding, will drop down too. If the  $V_{FB}$  drops below 0.4V, the output short protection will be triggered, switch will be turned off and  $V_{CC}$  will be latched for 16s, then  $V_{CC}$  will be discharged. Once  $V_{CC}$  is below the  $V_{OPR\_MIN}$ , the IC will be shut down and powered on again by the BUS voltage through the startup resistor. Power dissipation is low when output short protection happens.

#### 3. Over Current Protection (OCP)

The AL1665 has a built-in cycle by cycle over current protection of primary inductor current. When CS pin voltage reaches the voltage  $V_{CS\_CLAMP}$ , the switch will be turned off until next switch period. The maximum peak current ( $I_{PEAK\_MAX}$ ) of the inductor can be calculated as below:

$$I_{PEAK\_MAX} = \frac{V_{CS\_CLAMP}}{R_{CS}}$$

Where  $V_{CS\_CLAMP}$  means primary current clamp voltage that is 2V.  $R_{CS}$  is current sense resistor which is shown as Figure 1.

#### 4. CS Short Protection

When CS pin is shorted to GND, CS voltage is latched to zero. If CS is detected lower than 0.3V for 7 pulses, the CS short protection will be triggered, switch will be turned off and  $V_{CC}$  will be latched for 16s, then  $V_{CC}$  will be discharged. Once  $V_{CC}$  is below  $V_{OPR\_MIN}$ , the IC will be shut down and powered on again by the BUS voltage through the startup resistor. High rush current appears when CS is shorted to GND, and it may damage the components.

#### 5. Secondary Diodes/Primary Windings/Secondary Windings Short Protection

The CS voltage will be high when secondary diodes/primary windings/secondary windings are shorted. If the CS voltage is higher than  $V_{CS\_OCP}$ , the protection will be triggered, switch will be turned off and  $V_{CC}$  will be latched for 16s, then  $V_{CC}$  will be discharged. Once  $V_{CC}$  is below  $V_{OPR\_MIN}$ , the IC will be shut down and powered on again by the BUS voltage through the startup resistor. Power dissipation is low when output short protection happens.

#### 6. Thermal Fold-back Protection (TFP)

Connect a NTC between the NTC/PWM pin and ground to detect an over temperature condition. In response to a high temperature (detected if  $V_{NTC/PWM}$  drops below  $V_{TF(START)}$ ), the circuit gradually reduces the LED current down 50% of its nominal value when  $V_{NTC/PWM}$  reaches  $V_{TF(STOP)}$ , in accordance with the characteristic of Figure 3. If this thermal fold-back cannot prevent the temperature from rising (testified by  $V_{NTC/PWM}$  dropping below  $V_{OTP}$ ), the circuit would be latched off or enter the auto-recovery mode, and cannot be re-operated until  $V_{NTC/PWM}$  exceeds  $V_{OTP(ON)}$  to provide some temperature hysteresis (around +10°C typically). The OTP thresholds nearly correspond to the following resistances of the NTC: Thermal fold-back starts when  $R_{NTC} \leq R_{TF(START)}$  (11.7kΩ typically); Thermal fold-back stops when  $R_{NTC} \leq R_{TF(STOP)}$  (8.0kΩ typically); OTP triggers when  $R_{NTC} \leq R_{OTP(OFF)}$  (5.9kΩ typically); OTP is removed when  $R_{NTC} \geq R_{OTP(ON)}$  (8.0kΩ typically). At startup, when  $V_{CC}$  reaches  $V_{CC(ON)}$ , the OTP comparator is blanked for at least 250μs in order to allow the NTC/PWM pin voltage to reach its nominal value if a filtering capacitor is connected to the NTC/PWM pin. This would avoid flickering of the LED light during turn-on.

**Application Information** (continued)

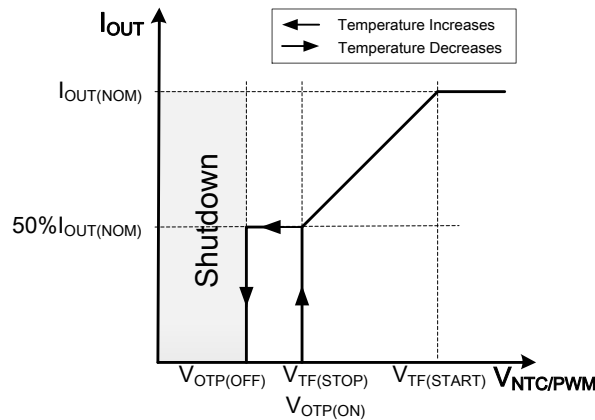

Figure 3. Output Current Reduction versus NTC/PWM Pin Voltage

**7. Over Temperature Protection (OTP)**

The AL1665 has built-in Over Temperature Protection (OTP) function. When the temperature goes up to +165°C, the over temperature protection will be triggered, which leads to a latch mode protection. When OTP happens, the system needs to be powered off and restart.

**Output Constant Current Control**

According to the definition of mean output current, the mean output current can be obtained as below:

$$I_{O\_MEAN} = \frac{1}{\pi} \cdot \int_0^{\pi} \frac{1}{2} \cdot I_{SP} \cdot \frac{t_{ONS}}{t_{SW}} dt$$

Where  $I_{O\_MEAN}$  is the mean output current;  $I_{SP}$  is the secondary peak current of transformer;  $t_{ONS}$  is the discharge time of secondary side of transformer;  $t_{SW}$  is the switch period.

According to the principle of AL1665 closed loop control, the voltage of  $R_{CS}$  will be sampled when switch is turned off and the value will be held until discharge time  $t_{ONS}$  is over. It can be described by following formula:

$$V_{REF} = \frac{I}{\pi} \int_0^{\pi} I_P \cdot R_{CS} \cdot \frac{t_{ONS}}{t_{SW}} dt$$

Where  $I_P$  is the primary peak current of transformer;  $R_{CS}$  is the current sense resistor which is shown as Figure 1.

$t_{ONS}$  is the discharge time of secondary side of transformer;  $t_{SW}$  is the switch period.  $V_{REF}$  is internal reference voltage that is equal to 0.4V.

The peak current at secondary side has the following relationship with primary side peak current, if the effect of the leakage inductor is neglected.

$$I_{SP} = N_{PS} \cdot I_P$$

Where  $N_{PS}$  is the turns' ratio of flyback transformer ( $N_{PS}=1$  for buck-boost);  $I_P$  is the primary peak current of the transformer.

According to these above formulas, the mean output current can be induced finally by the expression below:

$$I_{O\_MEAN} = \frac{N_{PS} \cdot V_{REF}}{2 \cdot R_{CS}}$$

Where  $I_{O\_MEAN}$  is the mean output current;  $R_{CS}$  is the current sense resistor which is shown as Figure 1 and Figure 2;

$V_{REF}$  is the internal reference voltage that is equal to 0.4V;  $N_{PS}$  is the turns' ratio of flyback transformer ( $N_{PS}=1$  for buck-boost); Therefore, the constant output current control can be realized with appropriate parameter design.

**Application Information** (continued)

**PF and THD Compensation Circuit**

In typical application, AL1665 can provide PF>0.9 and THD <40%. It can improve PF>0.95 and THD<20% by adding the compensation circuit as below. The V<sub>BUS</sub> is connected to bus line which is after the rectifier bridge. The COMP pin voltage will increase an offset that is almost followed with bus line voltage in the circuit. Due to the COMP voltage controls the switch-on time, the phase difference between input voltage and input current will be reduced, which can optimize the PF and THD. In the circuit, the range of resistor value R12 is from 800kΩ to 1.5MΩ, and the range of resistor value R13 is from 500Ω to 5.1kΩ. The Range of capacitance C11 is 1μF to 2μF. The PF and THD circuit can be improved by fine-tuning these components.

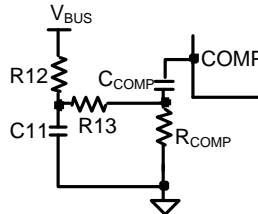

Figure 4. PF and THD Compensation Circuit

**Line Regulation Compensation Function**

The AL1665 can achieve good line regulation by adjusting FB pull-up resistor R<sub>FB1</sub> and CS external horizontal resistor R<sub>CS1</sub>. The circuit is shown as Figure 5. I<sub>FB3</sub> is the current that flows from GND to the internal FB pull-down resistor. I<sub>FB3</sub> will be detected during t<sub>ONP</sub> time, and flows into CS to compensate V<sub>REF</sub>.

$$V_{CS\_OFFSET} = \frac{K \cdot V_{IN} \cdot N_{AP} \cdot \frac{R_{FB2}}{R_{FB2} + R_{FB3}}}{R_{FB1} + \frac{R_{FB2} \cdot R_{FB3}}{R_{FB2} + R_{FB3}}} \cdot (R_{CS1} + R_{CS2})$$

V<sub>REF</sub> is the internal reference voltage that is equal to 0.4V; K is conversion coefficient of I<sub>FB3</sub> that is equal to 4; V<sub>IN</sub> is the input Voltage; N<sub>AP</sub> is the turns' ratio of auxiliary winding and primary winding; R<sub>FB2</sub> is the external FB pull-down resistor; R<sub>FB3</sub> is the internal FB pull-down resistor that is connected to the system during t<sub>ONP</sub> time, and equals to 207Ω; R<sub>CS2</sub> is the internal horizontal resistor that is 6kΩ.

As R<sub>FB1</sub> and R<sub>FB2</sub> are far larger than R<sub>FB3</sub>, the output current can be calculated approximately as following:

$$I_{O\_MEAN} = \frac{N_{PS}}{2 \cdot R_{CS}} \cdot (V_{REF} - V_{CS\_offset}) = \frac{N_{PS}}{2 \cdot R_{CS}} \cdot \left( V_{REF} - \frac{K \cdot V_{IN} \cdot N_{AP} \cdot (R_{CS1} + R_{CS2})}{R_{FB1}} \right)$$

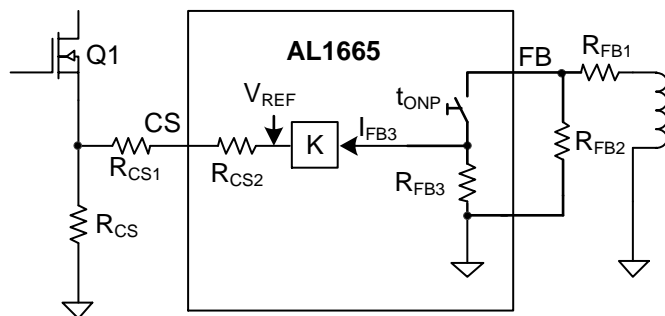

Figure 5. Line Regulation Compensation Circuit

**Application Information** (continued)

**Dimming Mode**

The AL1665 can support two dimming modes: analog dimming and PWM dimming.

**1. Analog Dimming Mode**

In analog dimming mode, the dimming signal is added to ADIM pin directly to realize dimming function. The setting circuit is shown as Figure 6. When  $V_{APWM}$  is higher than 2.5V, the driver will output 100% of rated current; when the voltage  $V_{ADIM}$  is in the range from 50mV to 2.5V, the output current will be changed linearly with the voltage  $V_{APWM}$ . The dimming curve is shown as Figure 7 and the dimming range is from 2% to 100%.

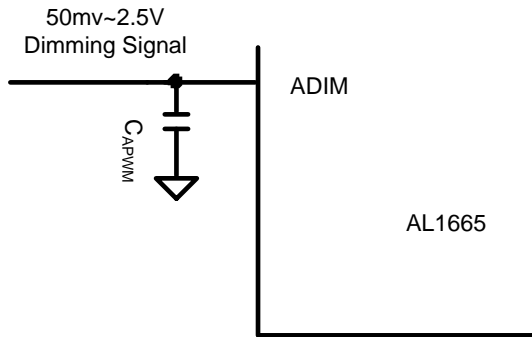

Figure 6. Analog Dimming Setting Circuit

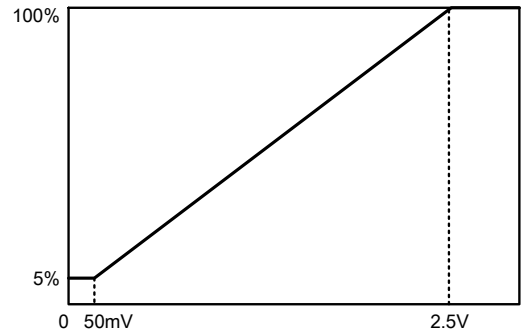

Figure 7. Analog Dimming Curve

**2. PWM Dimming Mode**

In PWM dimming mode, dimming signal will be added to NTC/PWM pin. The setting circuit is shown as Figure 8. The output current is chopped by the dimming signal directly. The logic high level of the dimming signal needs to be higher than 1V while the logic low level is lower than 0.5V. The switch is turned off at logic low level. The dimming curve is shown as Figure 9. The dimming range can be 100% to 0.5% with 1kHz frequency of PWM signal.

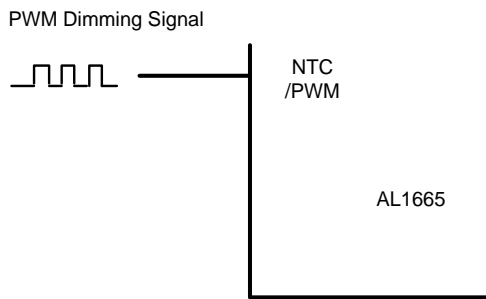

Figure 8. PWM Dimming Setting Circuit

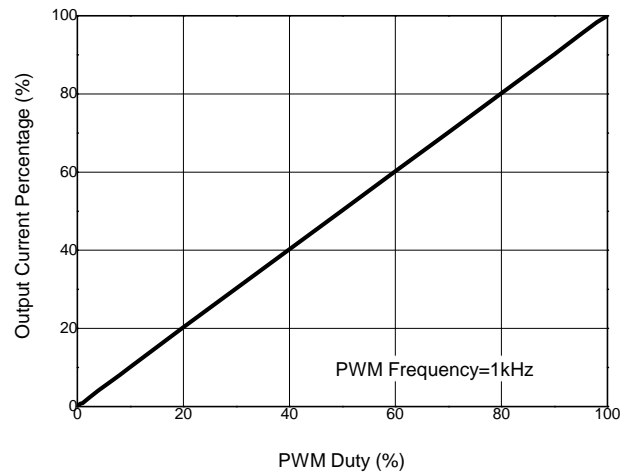

Figure 9. PWM Dimming Curve

## Application Information (continued)

### Operation Parameters Design

#### 1. Setting the Current Sense Resistor $R_{CS}$

The current sense resistance can be calculated as following:

$$R_{CS} = \frac{N_{PS} \cdot V_{REF}}{2 \cdot I_{O\_MEAN}}$$

Where  $I_{O\_MEAN}$  is the mean output current;  $R_{CS}$  is the current sense resistor which is shown as Figure 1;  $V_{REF}$  is the internal reference voltage that is equal to 0.4V;  $N_{PS}$  is the turns' ratio of flyback transformer ( $N_{PS}=1$  for buck-boost).

#### 2. Setting Transformer Selection (T1)

$N_{PS}$  is limited by the electrical stress of the switch MOSFET, can be calculated by below formula.

$$N_{PS} \leq \frac{V_{MOS\_ (BR)DS} \cdot 90\% - \sqrt{2} \cdot V_{IN\_MAX} - \Delta V_S}{V_O + V_{D\_F}}$$

Where  $V_{MOS\_ (BR)DS}$  is the breakdown voltage of the switch MOSFET.  $V_{IN\_MAX}$  is the max rated input voltage.  $\Delta V_S$  is the overshoot voltage clamped by RCD snobbier during OFF time.  $V_O$  is the output voltage.  $V_{D\_F}$  is the forward voltage of secondary diode.  $N_{PS}$  is the turns' ratio of flyback transformer ( $N_{PS}=1$  for buck-boost);

For boundary conduction mode and constant on time method, the peak current of primary inductance can be calculated as below.

$$I_P = \frac{2 \cdot \pi \cdot I_{O\_MEAN}}{N_{PS} \cdot \int_0^{\pi} \sin(\theta) \cdot \frac{\sqrt{2} \cdot V_{IN\_RMS} \cdot \sin(\theta)}{\sqrt{2} \cdot V_{IN\_RMS} \cdot \sin(\theta) + N_{PS} \cdot V_O} d\theta}$$

Where  $V_{IN\_RMS}$  is the rate input voltage;  $I_P$  is the primary inductance current.  $N_{PS}$  is the turns' ratio of flyback transformer ( $N_{PS}=1$  for buck-boost);  $I_{O\_MEAN}$  is the mean output current;  $V_O$  is the output voltage.

The switching frequency is not constant for AL1665 due to boundary conduction mode. To set the minimum switching frequency  $f_{MIN}$  at the crest of the minimum AC input, primary inductance can be obtained by below formula.

$$L_P = \frac{\sqrt{2} \cdot V_{IN\_RMS} \cdot N_{PS} \cdot V_O}{I_P \cdot (\sqrt{2} V_{IN\_RMS} + N_{PS} V_O) \cdot f_{MIN}}$$

Where  $V_{IN\_RMS}$  is the rate input voltage;  $I_P$  is the primary inductance current.  $N_{PS}$  is the turns' ratio of flyback transformer ( $N_{PS}=1$  for buck-boost);  $V_O$  is the output voltage;  $f_{MIN}$  is the minimum switching frequency at the crest of the minimum AC input.

According to the Faraday's Law, the winding number of the inductance can be calculated by:

$$N_P = \frac{L_P \cdot I_P}{A_e \cdot B_m}$$

$$N_S = \frac{N_P}{N_{PS}}$$

Where,

$A_e$  is the core effective area.

$B_m$  is the maximum magnetic flux density.

**Ordering Information**

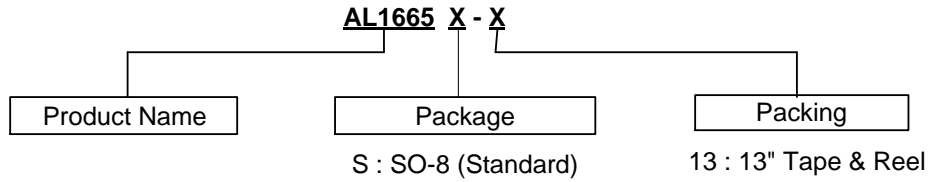

Part Number	Package Code	Package	13" Tape and Reel	
			Quantity	Part Number Suffix
AL1665S-13	S	SO-8 (Standard)	4000/Tape & Reel	-13

**Marking Information**

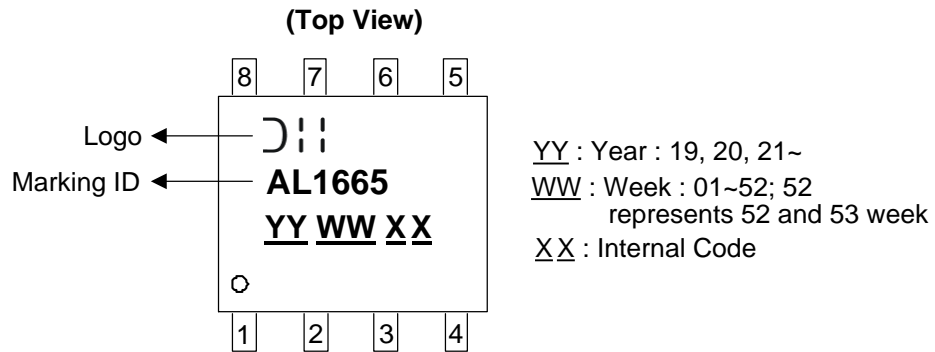

NEW PRODUCT

**Package Outline Dimensions** (All dimensions in mm.)

Please see <http://www.diodes.com/package-outlines.html> for the latest version.

(1) Package Type: SO-8 (Standard)

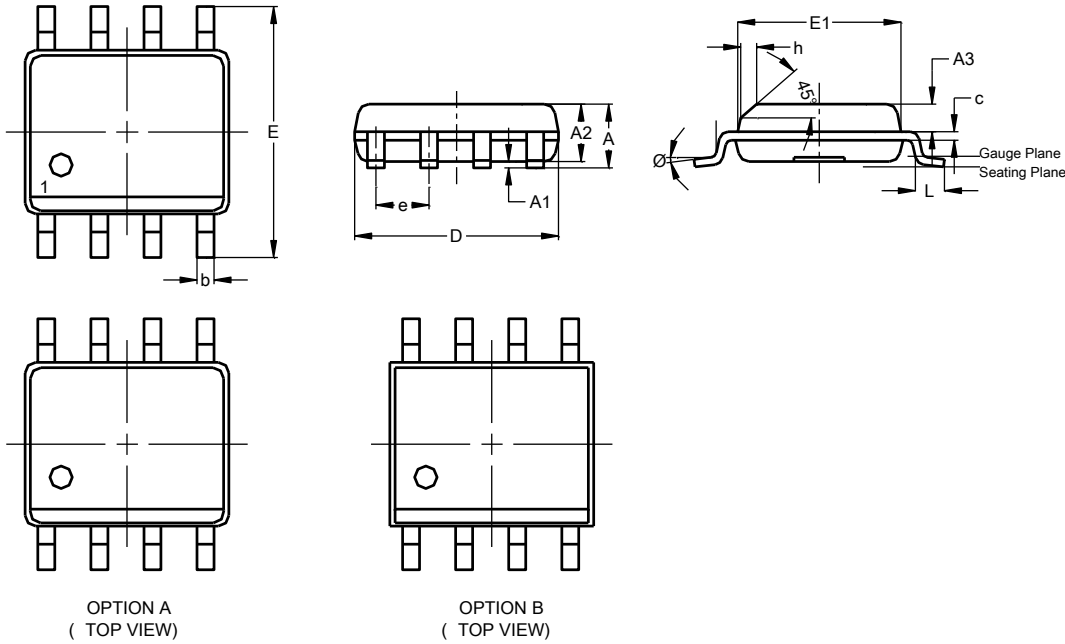

NEW PRODUCT

**Suggested Pad Layout**

Please see <http://www.diodes.com/package-outlines.html> for the latest version.

(1) Package Type: SO-8 (Standard)

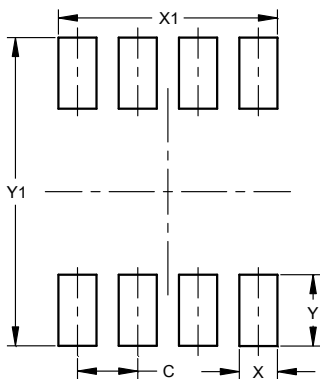

Dimensions	Value (in mm)
C	1.27
X	0.802
X1	4.612
Y	1.505
Y1	6.50

**IMPORTANT NOTICE**

DIODES INCORPORATED MAKES NO WARRANTY OF ANY KIND, EXPRESS OR IMPLIED, WITH REGARDS TO THIS DOCUMENT, INCLUDING, BUT NOT LIMITED TO, THE IMPLIED WARRANTIES OF MERCHANTABILITY AND FITNESS FOR A PARTICULAR PURPOSE (AND THEIR EQUIVALENTS UNDER THE LAWS OF ANY JURISDICTION).

Diodes Incorporated and its subsidiaries reserve the right to make modifications, enhancements, improvements, corrections or other changes without further notice to this document and any product described herein. Diodes Incorporated does not assume any liability arising out of the application or use of this document or any product described herein; neither does Diodes Incorporated convey any license under its patent or trademark rights, nor the rights of others. Any Customer or user of this document or products described herein in such applications shall assume all risks of such use and will agree to hold Diodes Incorporated and all the companies whose products are represented on Diodes Incorporated website, harmless against all damages.

Diodes Incorporated does not warrant or accept any liability whatsoever in respect of any products purchased through unauthorized sales channel. Should Customers purchase or use Diodes Incorporated products for any unintended or unauthorized application, Customers shall indemnify and hold Diodes Incorporated and its representatives harmless against all claims, damages, expenses, and attorney fees arising out of, directly or indirectly, any claim of personal injury or death associated with such unintended or unauthorized application.

Products described herein may be covered by one or more United States, international or foreign patents pending. Product names and markings noted herein may also be covered by one or more United States, international or foreign trademarks.

This document is written in English but may be translated into multiple languages for reference. Only the English version of this document is the final and determinative format released by Diodes Incorporated.

**LIFE SUPPORT**

Diodes Incorporated products are specifically not authorized for use as critical components in life support devices or systems without the express written approval of the Chief Executive Officer of Diodes Incorporated. As used herein:

A. Life support devices or systems are devices or systems which:

1. are intended to implant into the body, or
2. support or sustain life and whose failure to perform when properly used in accordance with instructions for use provided in the labeling can be reasonably expected to result in significant injury to the user.

B. A critical component is any component in a life support device or system whose failure to perform can be reasonably expected to cause the failure of the life support device or to affect its safety or effectiveness.

Customers represent that they have all necessary expertise in the safety and regulatory ramifications of their life support devices or systems, and acknowledge and agree that they are solely responsible for all legal, regulatory and safety-related requirements concerning their products and any use of Diodes Incorporated products in such safety-critical, life support devices or systems, notwithstanding any devices- or systems-related information or support that may be provided by Diodes Incorporated. Further, Customers must fully indemnify Diodes Incorporated and its representatives against any damages arising out of the use of Diodes Incorporated products in such safety-critical, life support devices or systems.

Copyright © 2019, Diodes Incorporated

[www.diodes.com](http://www.diodes.com)



## X-ON Electronics

Largest Supplier of Electrical and Electronic Components

*Click to view similar products for [LED Lighting Drivers](#) category:*

*Click to view products by [Diodes Incorporated](#) manufacturer:*

Other Similar products are found below :

[LV5235V-MPB-H](#) [MB39C602PNF-G-JNEFE1](#) [MIC2871YMK-T5](#) [AL1676-10BS7-13](#) [AL1676-20AS7-13](#) [AP5726WUG-7](#) [MX877RTR](#)  
[ICL8201](#) [IS31BL3228B-UTLS2-TR](#) [IS31BL3506B-TTLS2-TR](#) [AL3157F-7](#) [AP5725FDCG-7](#) [AP5726FDCG-7](#) [LV52204MTTBG](#)  
[SLG7NT4082VTR](#) [AP5725WUG-7](#) [STP4CMPQTR](#) [NCL30086BDR2G](#) [CAT4004BHU2-GT3](#) [LV52207AXA-VH](#) [AP1694AS-13](#)  
[TLE4242EJ](#) [AS3688](#) [IS31LT3172-GRLS4-TR](#) [TLD2311EL](#) [KTD2694EDQ-TR](#) [KTZ8864EJAA-TR](#) [IS32LT3174-GRLA3-TR](#)  
[ZXLD1374QESTTC](#) [AL1676-20BS7-13](#) [IS31FL3737B-QFLS4-TR](#) [IS31FL3239-QFLS4-TR](#) [KTD2058EUAC-TR](#) [KTD2037EWE-TR](#)  
[DIO5662ST6](#) [IS31BL3508A-TTLS2-TR](#) [MAX20052CATC/V+](#) [MAX25606AUP/V+](#) [BD6586MUV-E2](#) [BD9206EFV-E2](#) [BD9416FS-E2](#)  
[LYT4227E](#) [LYT6079C-TL](#) [MP3394SGF-P](#) [MP4689AGN-P](#) [MPQ4425AGQB-AEC1-Z](#) [TLD1311ELXUMA1](#) [TLE4309GATMA1](#)  
[MIC2873YCS-TR](#) [TPS92410DR](#)