

## Description

The AL1781/1782, a single/dual-channel dimmable Linear LED driver with PWM dimming control, is targeted for 1-Channel dimmable and 2-Channel tunable Smart Connected Lighting (SCL) applications. It serves as the LED driving element along with AC-DC Power Conversion Block and Intelligent wireless MCU as an emerging connected lighting applications.

The AL1781/1782 key merits attribute to dimming performance, low standby power, ease of system implementation and great scalability. It supports High Frequency E-flicker free PWM dimming with Deep Dimming Capability: Support 40kHz down to 4%, 10kHz down to 1.0%, 4kHz down to 0.4%, or 1kHz down to 0.1% with good dimming linearity. When no PWM signal is detected by AL1781/1782, it will automatically enter the low-power mode for power saving purpose to be in compliance with Energy Star standby power requirement for connected lighting requirements. Integrates Adaptive Thermal Management (ATM) scheme to minimize non-productive power dissipation.

The AL1781/1782 has protection features, including Under-Voltage-Lockout (UVLO), LED string Open/Short protection and Over-temperature protection (OTP).

AL1781 is a single channel and AL1782 is a dual-channel LED driver. They can support high LED current (up to total 1500mA) applications and they are available in Low thermal resistance TSSOP-16EP (Type DX) package.

## Features

- Input Voltage Range: 6.5V to 30V
- Independent PWM Dimming Control for Each Channel
- Adjustable Reference Current by External Reference Resistors
- LED Current Accuracy  $\leq \pm 4\%$
- Maximum LED Current 1500mA for AL1781 and 750mA Per Channel for AL1782
- Adaptive Thermal Management (ATM) Scheme to Minimize Power Dissipation
- Automatically Enter and Exit Low Standby Power Mode
- High Frequency E-flicker Free PWM Dimming
- Internal Protections:
  - Under Voltage Lockout (UVLO);
  - LED String Open/Short Protection;
  - Over-Temperature Protection (OTP): Thermal Shutdown and Auto Thermal Recovery
- Fault Reports: UVLO, OTP, LED Open/Short
- Ambient Temperature Range -40°C to +125°C
- TSSOP-16EP (Type DX): "Green" Molding Compound (No Br, Sb)
- **Totally Lead-Free & Fully RoHS Compliant (Notes 1 & 2)**
- **Halogen and Antimony Free. "Green" Device (Note 3)**

Notes: 1. No purposely added lead. Fully EU Directive 2002/95/EC (RoHS), 2011/65/EU (RoHS 2) & 2015/863/EU (RoHS 3) compliant.  
 2. See <https://www.diodes.com/quality/lead-free/> for more information about Diodes Incorporated's definitions of Halogen- and Antimony-free, "Green" and Lead-free.  
 3. Halogen- and Antimony-free "Green" products are defined as those which contain <900ppm bromine, <900ppm chlorine (<1500ppm total Br + Cl) and <1000ppm antimony compounds.

## Pin Assignments

(Top View)

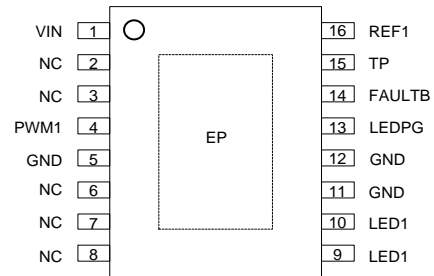

**TSSOP-16EP (Type DX) (AL1781)**

(Top View)

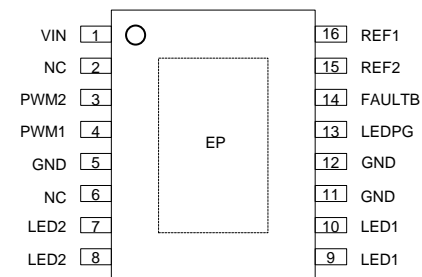

**TSSOP-16EP (Type DX) (AL1782)**

## Applications

- 1-Channel Dimmable Connected Light Bulbs
- 2-Channel Tunable White Connected Bulbs
- Multiple-Channel of Connected Lighting System
- Connected LED Tubes, Panel Lights, Troffers, and Ceiling Lights

**Typical Applications Circuit**

NEW PRODUCT

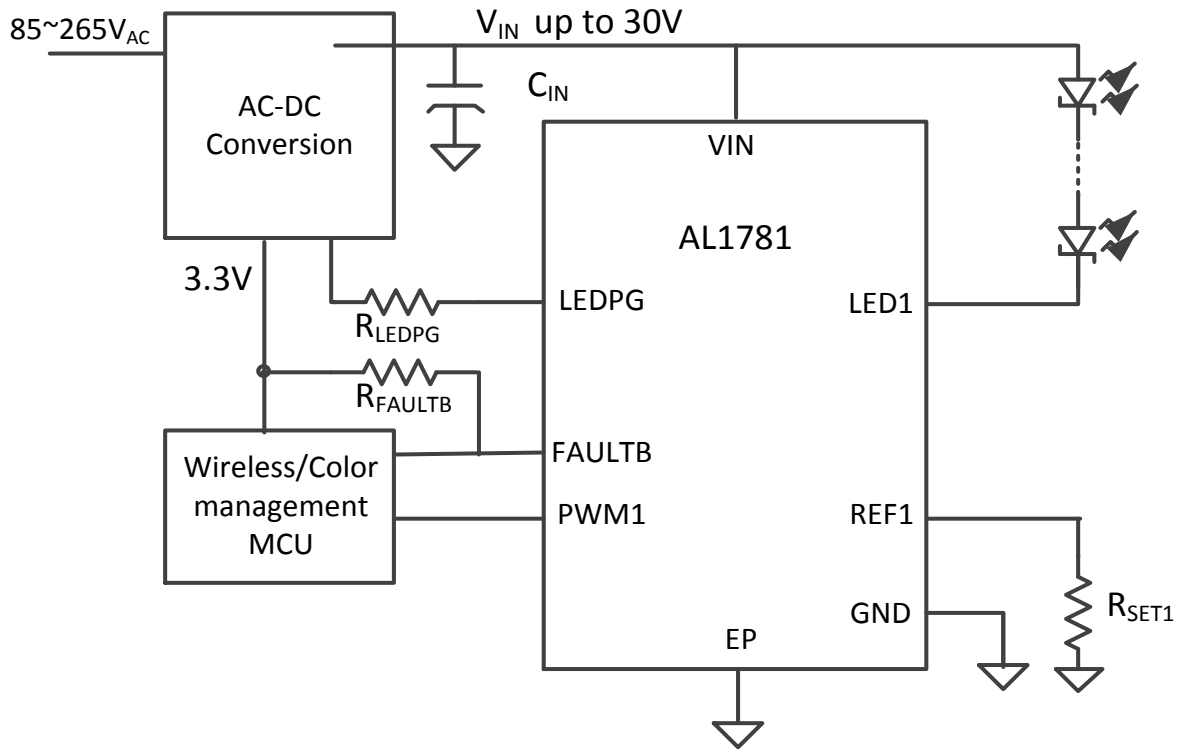

Figure 1. Channel Dimmable White

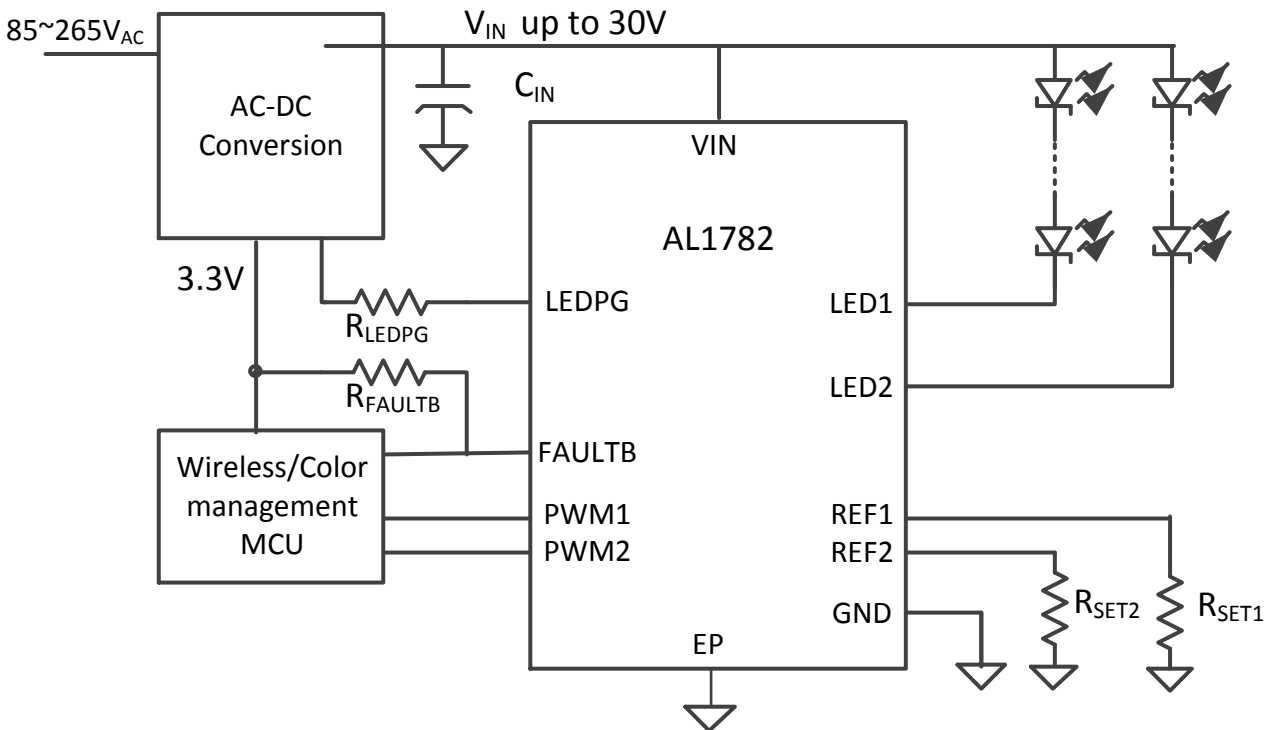
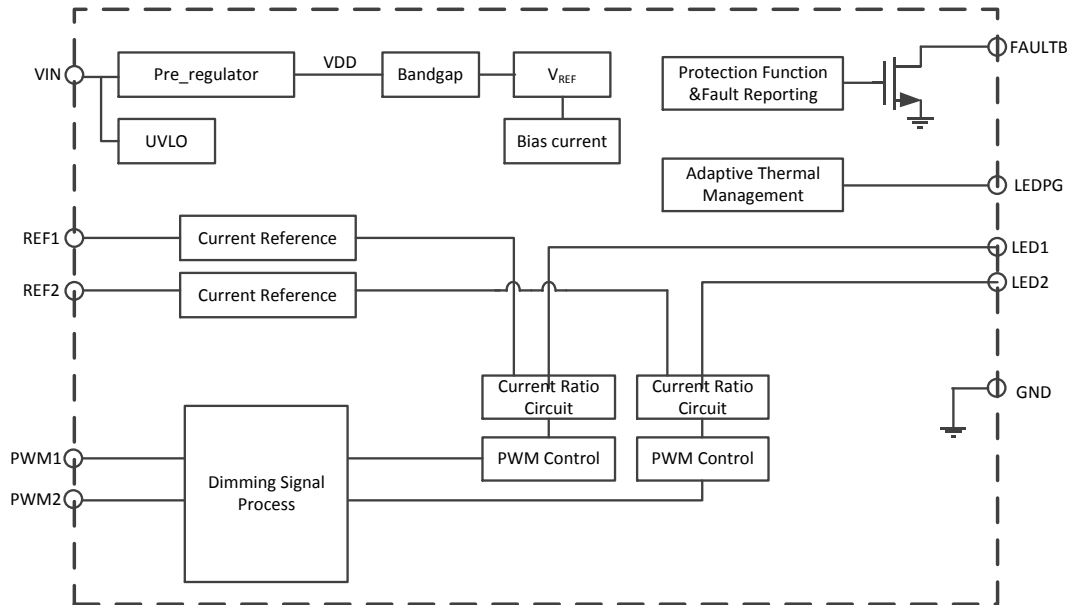

Figure 2. Channels Tunable White

## Pin Descriptions

Pin Name		Part Number	Descriptions
AL1781	AL1782	TSSOP-16EP (Type DX)	
VIN	VIN	1	Power Supply for LED Driver
NC	NC	2	Not connected
NC	PWM2	3	PWM Signal Input for Channel-2, Internally Pulled Down for AL1782; Not Connected for AL1781.
PWM1	PWM1	4	PWM Signal Input for Channel-1, Internally Pulled Down.
GND	GND	5	Ground for LED driver
NC	NC	6	Not connected
NC	LED2	7	Channel-2 LED Cathode for AL1782; Not Connected for AL1781.
NC	LED2	8	Channel-2 LED Cathode for AL1782; Not Connected for AL1781.
LED1	LED1	9	Channel-1 LED Cathode
LED1	LED1	10	Channel-1 LED Cathode
GND	GND	11	Ground for LED driver
GND	GND	12	Ground for LED driver
LEDPG	LEDPG	13	Adaptive thermal management adjusting current output.
FAULTB	FAULTB	14	Fault Report. Asserted Low to report faulty conditions. Needs an external pull-up resistor.
TP	REF2	15	Reference Current Setting through External Resistor ( $R_{SET2}$ ) for AL1782; TP pin for AL1781, it is a test pin for AL1781, not to input any voltage to TP pin.
REF1	REF1	16	Reference Current Setting through External Resistor ( $R_{SET1}$ )
EP	EP	Exposed PAD	Exposed pad.
			It should be externally connected to GND and thermal mass for enhanced thermal impedance.
			It should not be used as electrical conduction path.

**Functional Block Diagram**



Functional Block Diagram of AL1782 (Note 4)

Note: 4. REF2, PWM2 and LED2 are not applicable to AL1781.

**Absolute Maximum Ratings** (@T<sub>A</sub> = +25°C, unless otherwise specified.)

Symbol	Parameter		Rating	Unit
ESD	HBM	Human Body Model ESD Protection	4000	V
	CDM	Charged Device Model ESD Protection	1000	V
V <sub>VIN</sub>	Input Voltage for VIN		33	V
V <sub>LEDx</sub>	LEDx Voltage		33	V
V <sub>PWMx</sub> , V <sub>FAULTB</sub> , V <sub>LEDPG</sub>	PWMx, FaultB and LEDPG Voltage		7	V
V <sub>REFx</sub>	REFx Voltage		5	V
T <sub>J(MAX)</sub>	Maximum Junction Temperature		+160	°C
T <sub>ST</sub>	Storage Temperature Range		-65 to +150	°C

Caution: Stresses greater than the 'Absolute Maximum Ratings' specified above, may cause permanent damage to the device. These are stress ratings only; functional operation of the device at these or any other conditions exceeding those indicated in this specification is not implied. Device reliability may be affected by exposure to absolute maximum rating conditions for extended periods of time. Semiconductor devices are ESD sensitive and may be damaged by exposure to ESD events. Suitable ESD precautions should be taken when handling and transporting these devices.

**Recommended Operating Conditions** (@T<sub>A</sub> = +25°C, unless otherwise specified.)

Symbol	Parameter	Min	Max	Unit
V <sub>VIN</sub>	Input Voltage at VIN	6.5	30	V
T <sub>A</sub>	Operating Ambient Temperature	-40	+125	°C
V <sub>IH</sub>	High-Level Input Voltage on PWMx	1.4	5.5	V
V <sub>IL</sub>	Low-Level Input Voltage on PWMx	0	0.4	V

**Electrical Characteristics** (@ $T_A = +25^\circ\text{C}$ ,  $V_{IN} = +12\text{V}$ , unless otherwise specified.)

Symbol	Parameter	Test Conditions	Min	Typ	Max	Unit
$V_{IN\_UVLO}$	VIN UVLO Voltage	$V_{IN}$ Rising	—	6	—	V
$V_{IN\_UVHYS}$	VIN UVLO Hysteresis	$V_{IN}$ Falling	—	300	—	mV
$V_{IN\_OVP}$	VIN OVP Voltage	$V_{VIN}$ Rising when $I_{VIN} > 5\text{mA}$	—	33	—	V
$I_{MAX\_VIN\_OVP}$	Maximum VIN OVP Current	$V_{IN} > V_{VIN\_OVP}$	—	7	—	mA
$I_{VIN\_Low\_Power}$	VIN Supply Current at Low-Power Mode	Low-Power Mode, PWMx are "L",	—	300	—	$\mu\text{A}$
$I_{VIN\_Q}$	VIN Quiescent Supply Current	Enabled, LEDx Floating, PWMx are "H", $R_{SETx}$ is 12k $\Omega$	—	1.5	—	mA
$V_{IL(PWMx)}$	PWM Low Voltage	—	—	—	0.4	V
$V_{IH(PWMx)}$	PWM High Voltage	—	1.4	—	—	V
$F_{PWMx}$	PWM Frequency	—	0.5	—	40	kHz
$I_{(PWMx-PD)}$	PWM Internal Pulldown	$V_{PWMx} = 5\text{V}$	0.35	—	3.5	$\mu\text{A}$
$t_{PWMx\_MIN\_ON}$	Minimum PWMx On Time	—	—	2.5	—	$\mu\text{s}$
$t_{PWMx\_Low\_Power}$	Low-Power Time	—	—	4	—	ms
$V_{REFx}$	Reference Voltage	—	1.47	1.5	1.53	V
$I_{REFx}$	Reference Current	$R_{SETx} = 12\text{k}\Omega$	—	125	—	$\mu\text{A}$
$I_{LED1\_NOM}$	Regulation Current for Channel 1 (AL1781)	$R_{SETx} = 12\text{k}\Omega$	—	500	—	mA
	Regulation Current for Channel 1 (AL1782)	$R_{SETx} = 12\text{k}\Omega$	—	250	—	mA
$I_{LED2\_NOM}$	Regulation Current for Channel 2	$R_{SETx} = 12\text{k}\Omega$	—	250	—	mA
$V_{LEDx\_REG}$	Minimum LED Regulation Voltage	$I_{LEDx} = 250\text{mA}$	—	250	—	mV
$I_{LEDx\_LEAK}$	LEDx Leakage Current	$V_{PWMx} = 0\text{V}$ , $V_{LEDx} = +12\text{V}$	—	0.1	2	$\mu\text{A}$
$I_{LEDx\_ACCURACY}$	LEDx Current Accuracy	$R_{SETx} = 12\text{k}\Omega$	-4.0	—	4.0	%
$V_{LEDxSHP}$	LED Short Protection Threshold	—	—	9	—	V
$T_{LEDxSHDg}$	Short-detection Deglitch	100% Duty-Cycle	—	4	—	ms
$N_{LEDxSHDg}$		PWM Dimming (Count the Number of Continuous Cycles when LED Short is Detected)	—	15	—	Cycles
$t_{LEDxSH\_HICCUP}$	LED Short Protection Hiccup Time	—	—	128	—	ms
$t_{LEDxOPDg}$	Open-detection Deglitch	100% Duty-Cycle	—	6	—	ms
$N_{LEDxOPDg}$		PWM Dimming (Count the Number of Continuous Cycles when LED Open is Detected)	—	15	—	Cycles
$t_{LEDxOP\_HICCUP}$	LED Open Protection Hiccup Time	—	—	128	—	ms
$t_{SS}$	Soft-start Time	$V_{PWMx} = 5\text{V}$ , 90% of $I_{LEDx\_NOM}$	—	200	—	$\mu\text{s}$
$I_{LEDPG\_FULL}$	LEDPG Full Current	—	—	32	—	$\mu\text{A}$
$I_{LEDPG\_LSB}$	LEDPG LSB Current	—	—	0.5	—	$\mu\text{A}$
$t_{LEDPG\_ADJUST}$	LEDPG Adjust Time	—	—	512	—	ms
$T_{SHDN}$	Thermal Shutdown Threshold	—	—	+160	—	$^\circ\text{C}$
$T_{HYS}$	Temperature Hysteresis	—	—	+30	—	$^\circ\text{C}$
$V_{FOL}$	FAULTB Output Low Voltage	$I_{FAULTB} = 1\text{mA}$	—	—	180	mV
$I_{FOH}$	FAULTB Leakage Current	$V_{FAULTB} = 5\text{V}$	—	—	1	$\mu\text{A}$
$\theta_{JA}$	Thermal Resistance Junction-to-Ambient	TSSOP-16EP (Type DX) (Note 5)	—	50	—	$^\circ\text{C/W}$
$\theta_{JC}$	Thermal Resistance Junction-to-Case	TSSOP-16EP (Type DX) (Note 5)	—	15	—	$^\circ\text{C/W}$

Note 5: Device mounted on 2" x 2" FR-4 substrate PCB, 2oz copper, with minimum recommended pad on top layer and thermal vias to bottom layer ground plane.

**Typical Performance Characteristics**

NEW PRODUCT

VIN UVLO Voltage vs. Ambient Temperature

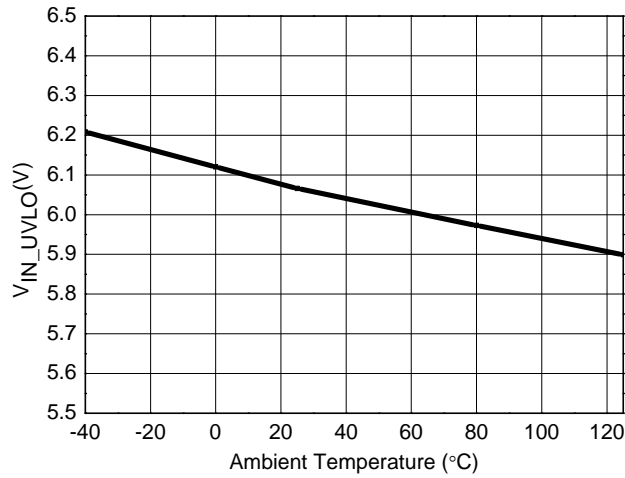

VIN OVP Voltage vs. Ambient Temperature

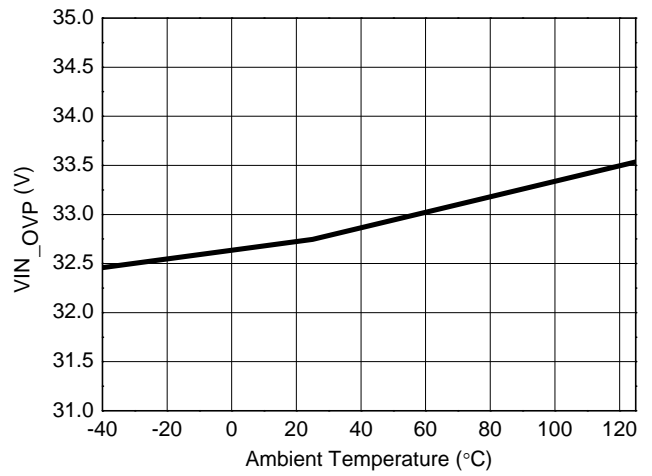

VIN Quiescent Supply Current vs. Ambient Temperature

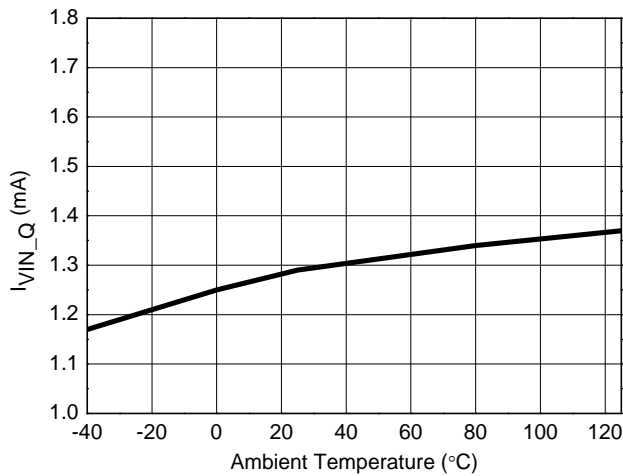

Reference Voltage for Channel 1 vs. Ambient Temperature

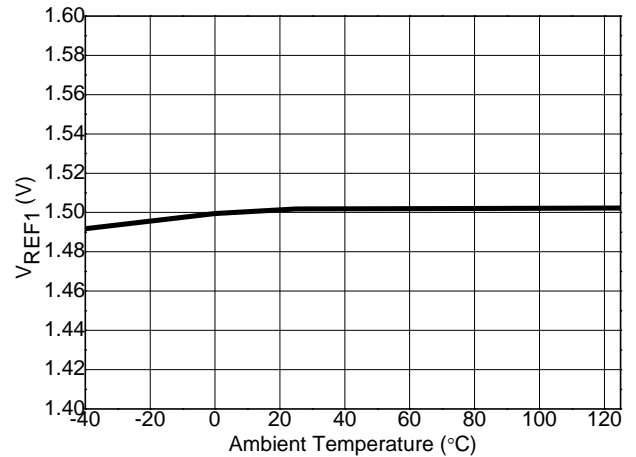

Regulation Current of Channel 1(AL1781) vs. Ambient Temperature      Regulation Current of Channel 1(AL1782) vs. Ambient Temperature

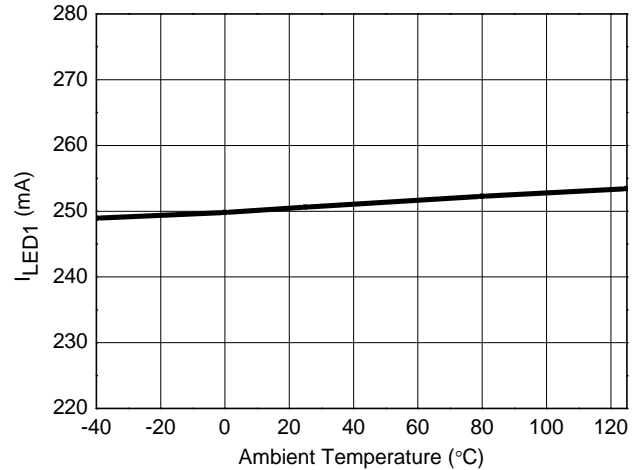
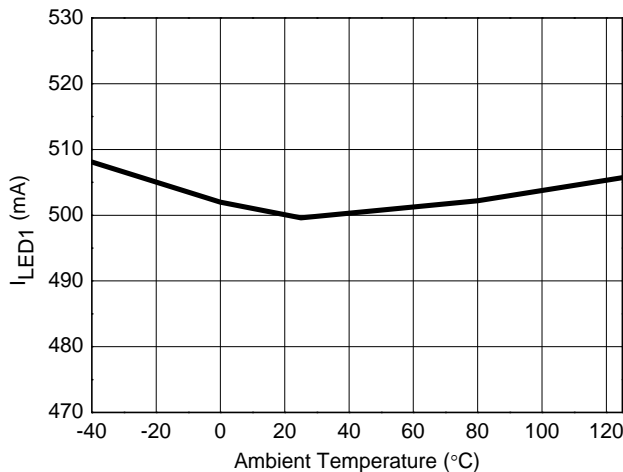

**Typical Performance Characteristics (Cont.)**

LED Current (AL1782) vs. PWM Duty (f=500Hz, 0~100%)



LED Current (AL1782) vs. PWM Duty (f=500Hz, 0~10%)

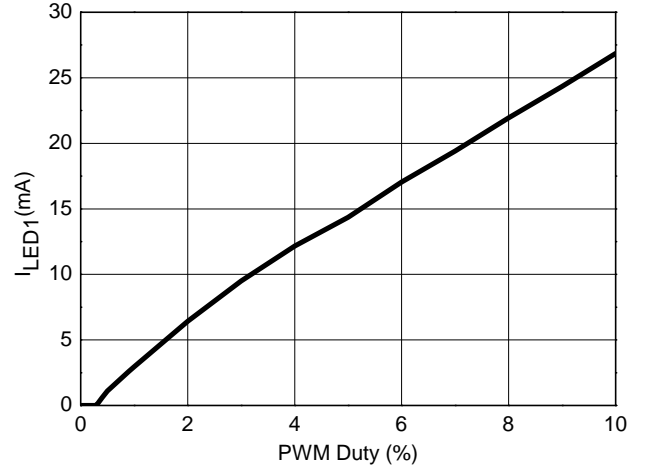

NEW PRODUCT

## Functional Description

The AL1781 and AL1782 are single-channel and dual-channel constant-current regulators optimized for 1-channel Dimmable White and 2-channel Tunable White Smart Connected Lighting (SCL) applications. It supports E-flicker free High Frequency PWM dimming with Deep Dimming Capability: Support 40kHz down to 4%, 10kHz down to 1.0%, 4kHz down to 0.4%, or 1kHz down to 0.1% with good dimming linearity. When no PWM signal is detected by AL1781/1782, it will automatically enter the low-power mode for power saving purpose to be in compliance with Energy Star standby power requirement for SCL bulbs. It also integrates Adaptive Thermal Management (ATM) scheme to minimize non-productive power dissipation. The AL1781/1782 has abundant of protection features, including Under-Voltage-Lockout (UVLO), LED string Open/Short protection and Over-temperature protection (OTP); when detecting these fault conditions, it will report the fault status on FAULTB pin.

### 1. Enable and Soft-Start LED Drivers

The AL1781/1782 is enabled when the voltage at any PWMx pin is greater than approximately 2.5V, and disabled when all PWMx are lower than 0.4V. Upon any PWMx pin is asserted and VIN pin is ramped up beyond minimum operation voltage, a soft start will be performed with a slew-rate-controlled current ramp over 200µs at LEDx output pins to minimize current overshoot through LED strings for optimal system reliability. When all PWMx are inactive for 4ms, The LED Driver will enter Low-Power mode with ultra-low standby power.

### 2. LED Current Setting and Capability

#### (1) LED Current Setting

The AL1781/1782 is designed to have individual channel current set by its corresponding current setting R<sub>SET</sub> resistor. The LED channel current level is expressed as below:

For AL1781:

$$I_{LED1} = 4000 * \frac{V_{REF}}{R_{SET1}}$$

For AL1782:

$$I_{LED1} = 2000 * \frac{V_{REF}}{R_{SET1}}$$

$$I_{LED2} = 2000 * \frac{V_{REF}}{R_{SET2}}$$

where  $V_{REF} = 1.5V$  nominally for all devices

For example, when an R<sub>SET</sub> of 6kΩ is used, Channel 1 of AL1781 provides current of 1000mA. For the same R<sub>SET</sub> setting, each channel of AL1782 provides same current amount of 500mA.

#### (2) LED Current Capability

The maximum current of each channel can drive up to 750mA with a total driving current up to 1500mA (refer to Table 1 below). The minimum channel current is recommended as in Table 2 in order to meet channel current accuracy and short protection specifications. Each channel can still be individually controlled by digital PWM dimming. The integrated low-side current sinks allow LED common-anode connections for cost effectiveness or different anode voltages for efficiency optimization.

Model Name	Channel 1	Channel 2	Total IC Current
AL1781	1500mA	Not Applicable	1500mA
AL1782	750mA	750mA	1500mA

**Table 1 Recommended Maximum Channel Current and Total IC Current for AL1781/1782**

Model Name	Channel 1	Channel 2	Total IC Current
AL1781	300mA	Not Applicable	300mA
AL1782	150mA	150mA	300mA

**Table 2 Recommended Minimum Channel Current and Total IC Current for AL1781/1782**

Along with bus-mode fault reporting, multiple devices can be employed together to increase current driving capability or channel count versatility. The maximum LED current for the channel can be adjusted up to 1500mA via R<sub>SET</sub> resistor for AL1781 and 750mA for AL1782.

Any two or more channels can be tied together to drive one LED string with aggregated current. So when current needed for any channel is greater than the maximum value the device can provide, two or more channels or devices can be paralleled together to provide the drive current needed.



## Functional Description (Cont.)

### 3. High Performance PWM Dimming

#### (1) Support High Frequency E-Flicker Free Dimming

For PWM-dimmed Light Sources, there are two important performance aspects to pay attention, namely, PWM frequency and deep dimming performance. While human eyes could not discern any flickering caused by PWM-dimming light sources over 200Hz, Electronic devices such as camera for smart phones could detect flickering (referred as e-Flicker) caused by certain much higher PWM-dimmed light sources. Generally speaking, the higher the PWM dimming signals applied to the light source, the less visible e-Flicker detected by electronic components.

AL1781/1782 provides PWM dimming control. The PWM frequency is recommended to be greater than 500Hz. For e-Flicker free operation, 4kHz or higher frequency is recommended. High level of PWM signal will turn on the current sink to flow through the LED and low level of PWM signal will turn it off. Consequently, the LED current and LED brightness of each corresponding channel can be adjusted.

#### (2) Deep Dimming Capability

Measured light is linearly proportional to the measured current and PWM duty cycle. The perceived light by human eyes has a non-linear relationship with measured light. Human eyes are also found to be more sensitive to low light situations. For example, 10% measured light is perceived to be 32% of the original full light. 5% measured light is perceived to be 22% of the original full light. 1% measured light is perceived to be 10% of the original full light. Therefore, deep dimming capability is required to save significant energy as well as to provide adequate visible light output.

The pulse width of PWM signal applied to AL1781/1782 can be as low as 1 $\mu$ s to support down to 0.1%@1kHz deep dimming capability still with good linearity. Further deeper dimming through higher frequency PWM signals is possible which maintains reasonable linearity – 0.1%@1kHz, 0.4%@4kHz, or 1.0%@10kHz. PWM signals can be driven static low or high to turn off or on the corresponding channels constantly.

### 4. Low-Power Mode and Adaptive Thermal Management (ATM)

#### (1) Automatic Entrance/Exit to/ from Low-Power Mode

For SCL applications, the brightness and CCT tuning are done through LED emitter light mixing by changing average current through associated PWM signal of each emitter channel. When no PWM signal is detected by AL1781/1782, it will automatically enter the low-power mode for power saving purpose. When in this low-power mode, the power consumption is reduced to  $I_{VIN\_Low\_Power}$  (VIN supply Current at Low-Power mode) \* VIN (VIN for LED driver circuit). In the case of  $R_{SET}$  is 6k $\Omega$  (for 500mA channel current in AL1782,  $I_{VIN\_Low\_Power}$  is 0.3mA) and VIN is 25V, or 7.5mW for the LED driver portion. To be in compliance with Energy Star standby power requirement for SCL bulbs, this power saving is very significant.

When any PWM signal driving AL1781/1782 is detected, the AL1781/1782 will automatically exit the low power mode and perform its designated functions properly.

#### (2) Adaptive Thermal Management (ATM) Scheme

The Input Voltage to drive all attached Emitter Strings needs to maintain voltage level over required total  $V_F$  of emitter string plus minimum voltage headroom (VLED\_REG). On the other hand, excessive voltage headroom provided needs to be absorbed by AL1781/1782, which increases heat dissipation to complicate thermal management. Power Good reporting serves as a mechanism to detect the LED power supply condition and adjust the supply voltage to LEDs through AC-DC voltage feedback in order to minimize unnecessary overdrive voltage to the LED Driver and optimize the efficiency.

AL1781/1782 constantly detects and reports  $V_{LEDx}$  (voltage measured at Pin LEDx) output headroom condition by ejecting a voltage-adjustment current out of LEDPG pin. If the  $V_{LEDx}$  in any channel is lower than or close to the dropout voltage required by the regulator (VLED\_REG) while the channel is enabled with PWMx, there will be no voltage-adjustment current. During PWMx low period, internal LEDPG will not report insufficient headroom for that channel. If the  $V_{LEDx}$  voltage in each channel is higher than the dropout voltage required by the regulator ( $V_{LEDx\_REG}$ ), the LEDPG will inject the adjustment current. The ATM scheme utilizes LEDPG information and provide feedback information to the power conversion circuitry to fine tune the LED power to ensure minimum voltage headroom to drive emitter strings while maintain regulation channel current.

### 5. Protection Features and Fault Reporting

#### (1) Under Voltage Lockout

Under-voltage lockout function (UVLO) guarantees that the device is initially off during start-up. AL1781/1782 is not turned ON until the power supply has reached 6V. Whenever the input voltage falls below approximately 5.7V, the device is turned off. The UVLO circuit has a hysteresis of 300mV. During UVLO, a FAULTB status will be reported.

#### (2) LED Open and Short Protection

AL1781/1782 detects the LED status by monitoring the current and voltage status of the LED strings. When an abnormal condition occurs (LED Open or LED Short), FAULTB is asserted low for 128ms and the abnormal channel will be retested afterward to check if the abnormal condition is cleared. LED driver will be re-activated if the abnormal condition is cleared. In the case of LED Open or Short, all non-affected channels remain in the normal operating condition.

## Functional Description (Cont.)

### (3) Over Temperature Protection

Thermal protection prevents the IC from damage when the die temperature exceeds safe margins. The AL1781/1782 features Over Temperature Protection (OTP). When the junction temperature reaches +160°C, the device will enter thermal shut down mode in which all current sinks are shut down and no current flows to LED strings. The normal current level can be automatically restored to its set current from OTP by triggering a Soft Start when the temperature lowers down below +130°C. LED Driver's Thermal Shutdown Mode will also be reported as a FAULTB.

### (4) Fault Reporting

Fault reporting serves as a good communication channel between LED drivers and intelligent MCU unit. AL1781/1782 detects and reports the FAULTB status upon the occurrence of Thermal Shutdown in OTP, LED Short, LED Open, and UVLO. FAULTB pin is an open-drain output design. Multiple devices can share a single FAULTB signal by connecting all FAULTB pins together with an external pull-up resistor. Any FAULTB assertion from any device pulls the signal down and informs MCU of the faulty condition.

## 6. Examples of Smart Light Bulb and LED Panel Light

### (1) System Configurations

Emerging smart LED light bulbs, including Tunable White and Tunable Color products used in either wired or wireless control applications, address human needs for energy saving, light quality scene setting and entertainment light management. Typical block diagram of a smart light bulb, consisting of four major functional blocks – AC-DC Power Conversion, Wireless/Color Management MCU, LED driver and an emitter module. AL1781/1782 family fits well with emerging Smart Connected Light bulbs illustrating as below:

1-Channel Dimmable White (Figure 1)

Brightness adjustment with Fixed Correlated Color Temperature (CCT) White

2-Channel Tunable White (Figure 2)

CCT Tuning with range from 2,700k to 6,500k

For wireless-enabled Smart Connected LED Panel Lights, Troffers and Ceiling Lights, AL1781/1782 can be used to drive emitter string(s) for either 1-channel Dimmable White or 2-channel Tunable White applications as shown in Figure 1 and Figure 2.

### (2) Interface with Emitter Strings and AL1781/1782

The AC-DC Power Conversion provides necessary output constant voltages (CVs) to power the MCU and the LED Driver blocks of the entire smart light bulbs. Typical applications for smart light bulbs might require 3.3V for MCU and 12/24V for LED emitter strings of mainstream smart light bulbs. Anodes of top LED emitter strings are connected to 12/24V power supply. And cathodes of bottom LED emitter strings are connected to LEDx pins of AL1781/1782.

### (3) Interface with Wireless/Color Management MCU and AL1781/1782

The main physical interfaces between MCU and AL1781/1782 are PWMx pins and FAULTB. MCU activates the PWMx (asserted high) to turn on AL1781/1782 in active state for normal LED lighting operation. When PWMx pins are asserted low for 4mS, the entire AL1781/1782 enters Low-Power mode with minimum power consumption. For typical light dimming or mixing operations, MCU generates proper PWM signals output through PWMx pins. In case of any general fault occurs in AL1781/1782, FAULTB pin is asserted LOW to interrupt MCU for proper actions.

### (4) LED Driver Design Topology and Implementation

For AL1781/1782-powered LED Driver/Emitter block adopts a multi-channel LED driver structure with PWM dimming control for each channel. The parallel LED driver channel structure covers mainstream applications for Smart Connected Lighting products. Given the maximum allowable input voltage of 30V, AL1781/1782 can support a LED string up to 8 emitters of W, B, G (assuming LED Emitter Forward Voltage Drop,  $V_F \sim 3.1V$ ) or 10 emitters of R (assuming  $V_F \sim 2.2V$ ) in series typically. It is still possible to driver more than 8 emitters by slitting LED Emitter string voltage and VIN as long as VIN is below 30V.

For 1-channel Dimmable White (Figure 1), the Reference Current ( $I_{REF1}$ ) of AL1781 is set by an external resistor  $R_{SET1}$ . In the case using 4kΩ as  $R_{SET1}$ , Channel 1 of AL1781 will be driving emitter string(s) with a total constant current of 1500mA.

As an example of a 2-channel Tunable White light bulb design (Figure 2), an AL1782 drives two emitter strings, namely, CCTcold (6,500k) and CCTwarm (2,700k). Using  $R_{SET1}$  and  $R_{SET2}$  at 4kΩ, the maximum current for Channel 1 and Channel 2 will be 750mA if each PWM signal is turned on. The associated MCU could generate suitable PWM patterns to meet the required CCT tuning to target light output. The associated MCU could generate suitable PWM patterns to meet the required CCT tuning to target light output.  $R_{SET1}$  and  $R_{SET2}$  can also be set at different values to obtain different channel current if desired. However, the total channel current is advised not to exceed a total of 1500mA with hard-limit to 750mA maximum for each channel.

---

## Functional Description (Cont.)

---

### (5) Support Higher Current

While the recommended maximum  $I_{LED1}$  and  $I_{LED2}$  are at 750mA for AL1782, by setting  $R_{SET1}$  and  $R_{SET2}$  at 4k $\Omega$ , the system design can drive an LED string with higher current by connecting the cathodes of the LED emitter string to two or more LED channel outputs (LEDx) and associated PWM pins (PWMx) with the same PWM signal from the MCU. The result current through the LED emitter string is the sum of each current through the individual channels.

Similarly, it is also possible to further increase the current for a specific channel by connecting two or more AL1781/1782 IC chips in parallel and drive all associated PWM pins with a common PWM signal.

### (6) Special System Design Considerations

Three key Smart Light Bulb system design issues need to be carefully planned for system efficiency consideration. Any headroom voltage (over total voltage drops for all LED emitters in a string) in each channel will result in additional power consumption for AL1781/1782, which needs to be dissipated by AL1781/1782. System designers are advised to carefully plan for well forward-voltage-matched LED strings with Constant Voltage (CV) regulators to ensure that AL1781/1782 can properly dissipate heat for normal operations.

#### **V<sub>F</sub> Matching for Emitter Strings:**

It is crucial to match the total forward voltage drop ( $V_F$ ) of each LED string attached to a CV for optimal system efficiency.

#### **Multiple CVs to Match Emitter Module Design:**

The AC-DC Power Conversion block may need to support multiple CV outputs to power all emitter strings in a Smart Light Bulb design.

#### **Overall Thermal Management:**

Though there are various protection mechanisms built-in AL1781/1782, it is good practice to check maximum dimming pattern to avoid Thermal Shutdown (when AL1781/1782 junction temperature exceeds +160°C). Thermal resistivity  $\theta_{JA}$  (Junction-to-Ambient) of AL1781/1782 is 50°C/W. AL1781/1782 has to absorb any additional voltage headroom provided by the voltage input to the emitter strings. Therefore, the thermal management of AL1781/1782 must follow the following guidelines:

$$P_{Dmax} \text{ (Maximum Power Dissipation of AL1781/1782)} = (+160^\circ\text{C Junction Shutdown Temperature} - \text{Ambient Temperature, e.g. } +85^\circ\text{C}) / 50^\circ\text{C/W} = 1.5\text{W}$$

$$P_{Amax} \text{ (Power to be Absorbed by AL1781/1782)} = \Sigma(V_{LEDx} * \text{Current through the emitter string} * \text{Associated PWM Dimming Duty Cycle}) \text{ for all channels}$$

$$\text{Thermal Management Guideline} \quad P_{AMAX} < P_{DMAX}$$

**Ordering Information**

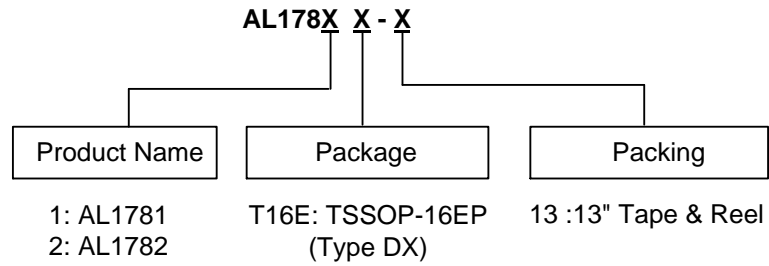

Part Number	Package Code	Packaging	13" Tape and Reel	
			Quantity	Part Number Suffix
AL1781T16E-13	T16E	TSSOP-16EP (Type DX) (Note 6)	2500/Tape & Reel	-13
AL1782T16E-13	T16E	TSSOP-16EP (Type DX) (Note 6)	2500/Tape & Reel	-13

Note: 6. For packaging details, go to our website at <https://www.diodes.com/design/support/packaging/diodes-packaging/>.

**Marking Information**

(1) TSSOP-16EP (Type DX)

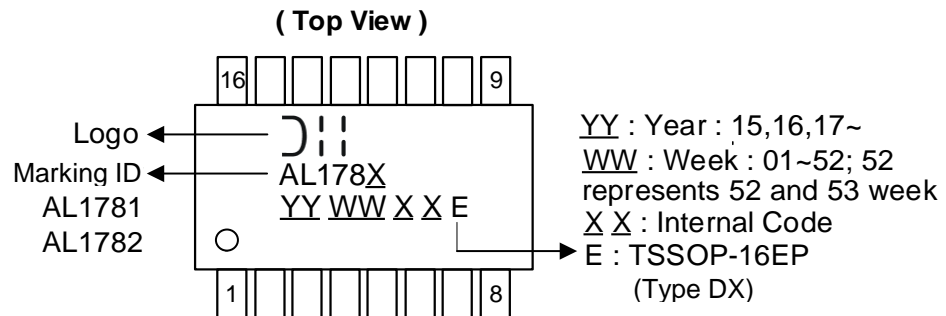

**Package Outline Dimensions**

Please see <http://www.diodes.com/package-outlines.html> for the latest version.

**TSSOP-16EP (Type DX)**

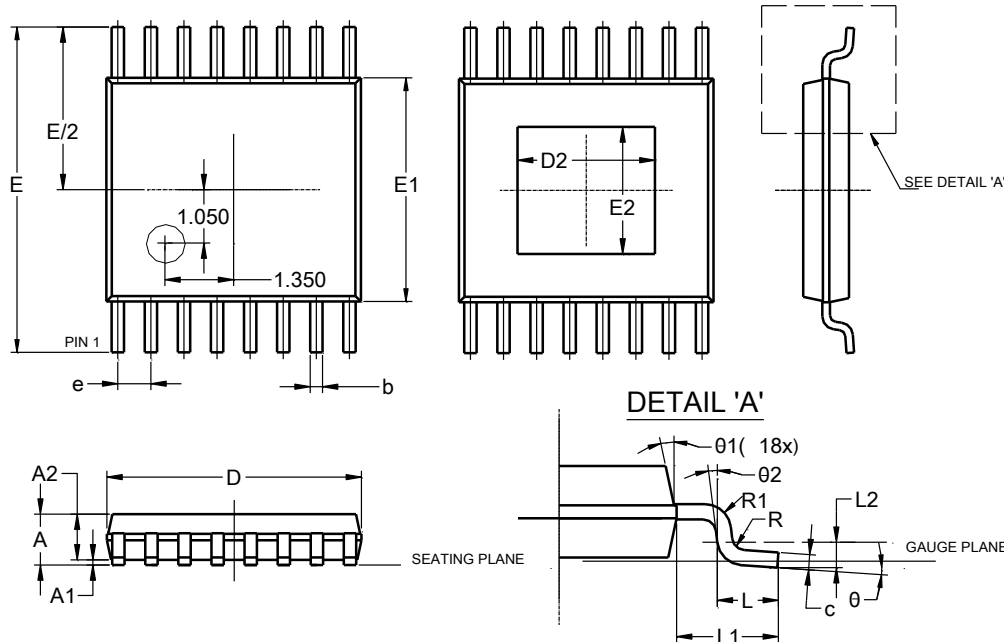

TSSOP-16EP (Type DX)			
Dim	Min	Max	Typ
A	--	1.08	--
A1	0.05	0.15	--
A2	0.80	0.93	--
b	0.19	0.30	--
c	0.09	0.20	--
D	4.90	5.10	--
D2	2.70	--	--
E	6.40 BSC		
E1	4.30	4.50	--
E2	2.50	--	--
e	0.65 BSC		
L	0.45	0.75	--
L1	1.00 REF		
L2	0.25 BSC		
R	0.09	--	--
R1	0.09	--	--
θ	0°	8°	--
θ1	5°	15°	--
θ2	0°	--	--
All Dimensions in mm			

**Suggested Pad Layout (Notes 7 and 8)**

Please see <http://www.diodes.com/package-outlines.html> for the latest version.

**TSSOP-16EP (Type DX)**

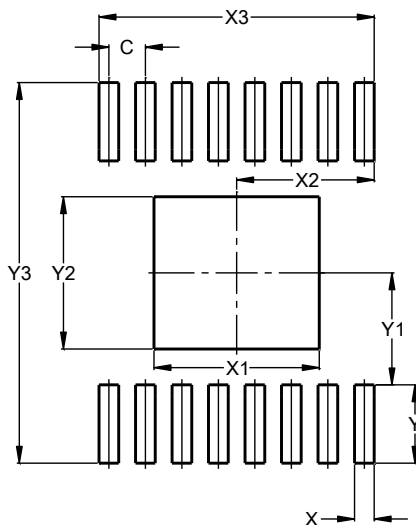

Dimensions	Value (in mm)
C	0.65
X	0.35
X1	2.94
X2	2.45
X3	4.90
Y	1.40
Y1	2.00
Y2	2.72
Y3	6.80

- Notes:
- The suggested land pattern dimensions have been provided for reference only, as actual pad layouts may vary depending on application. These dimensions may be modified based on user equipment capability or fabrication criteria. A more robust pattern may be desired for wave soldering and is calculated by adding 0.2 mm to the 'Z' dimension. For further information, please reference document IPC-7351A, Naming Convention for Standard SMT Land Patterns, and for International grid details, please see document IEC, Publication 97.
  - For high voltage applications, the appropriate industry sector guidelines should be considered with regards to creepage and clearance distances between device Terminals and PCB tracking.

**Minimum Packing Quantity** (Notes 9, 10 and 11)

—	Quantity	Tape Width	Part Number Suffix
13" Reel	2,500	12mm	-13

- Notes: 9. Package quantities given are for minimum packaging quantity only, not minimum order quantity. For minimum order quantity, please contact Sales Department.  
 10. No mixed date codes or partial quantity (less than minimum packaging quantity) per packaging is allowed.  
 11. In no case shall there be two or more consecutive components missing from any reel for any reason.

**Device Tape Orientation** (Notes 12 and 13)

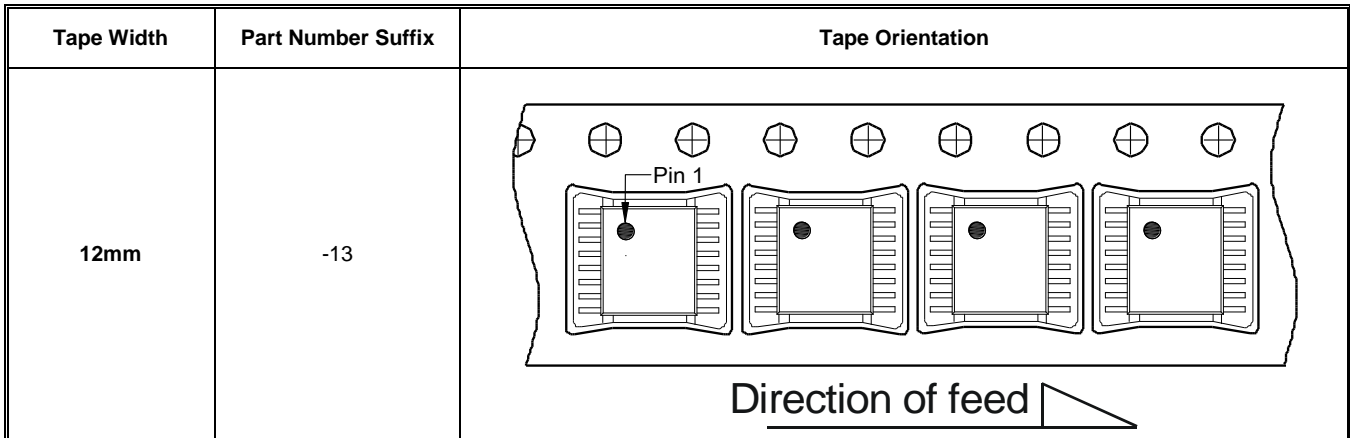

- Notes: 12. For part marking, refer to product datasheet.  
 13. Tape and package drawings are not to scale and are shown for device tape orientation only.

**Embossed Carrier Tape Specifications**

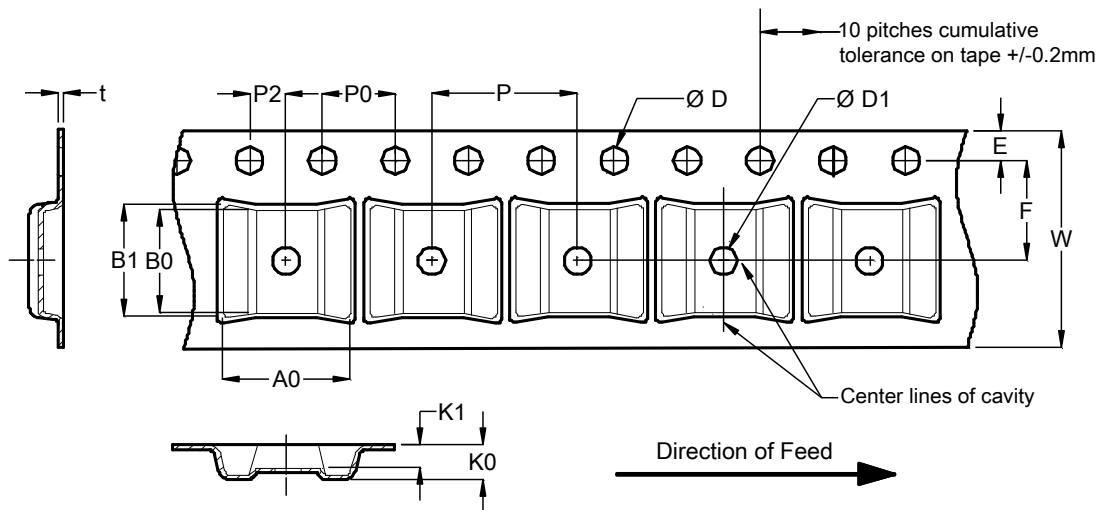

Tape Width (W)	Dimension	Value (mm)	Dimension	Value (mm)	Dimension	Value (mm)
12mm	A0	6.95	E	1.75 ±0.10	P0	4.0 ±0.10
	B0	5.60	F	5.50 ±0.05	P2	2.0 ±0.05
	B1	6.30	K0	1.60	t	0.30 ±0.05
	D	1.50 +0.1/-0.0	K1	1.20	W	12.0 ±0.30
	D1	1.50 min	P	8.0 ±0.10	—	—
	A0 B0 K0	The clearance between the component and the cavity must comply to the rotational and lateral movement requirement provided in figures in the "Maximum Component Movement in Tape Pocket" section.				

NEW PRODUCT

**Embossed Carrier Tape Specifications (Cont.)**

NEW PRODUCT

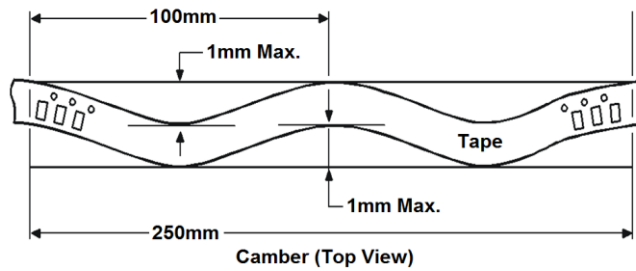
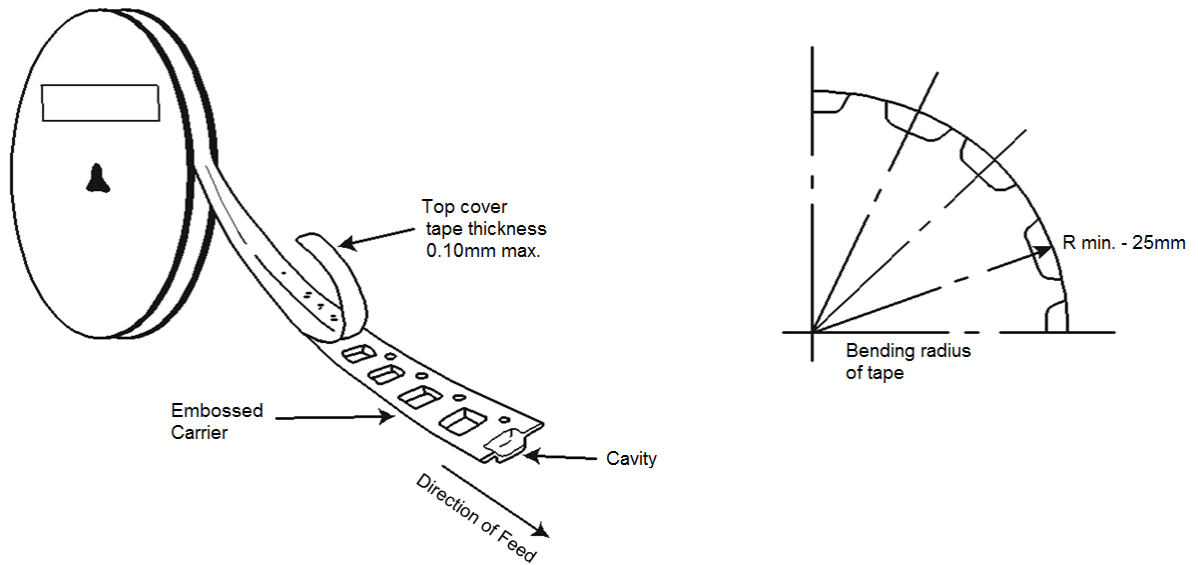

Allowable camber to be 1mm/100mm tape, non-cumulative

**Maximum Component Movement in Tape Pocket**

**Component Lateral Movement**  
8mm Tape

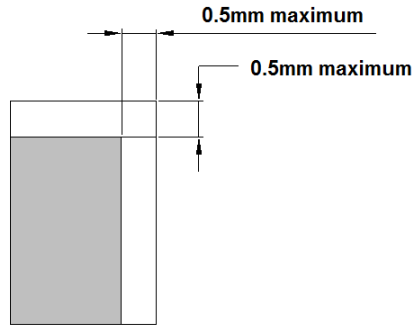

**Maximum Component Rotation**  
Top View

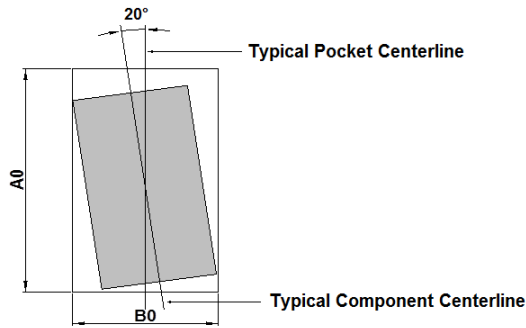

**Maximum Component Rotation**  
Side View

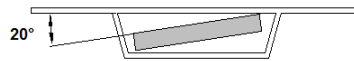

NEW PRODUCT



**Surface Mount Reel Specifications**

NEW PRODUCT

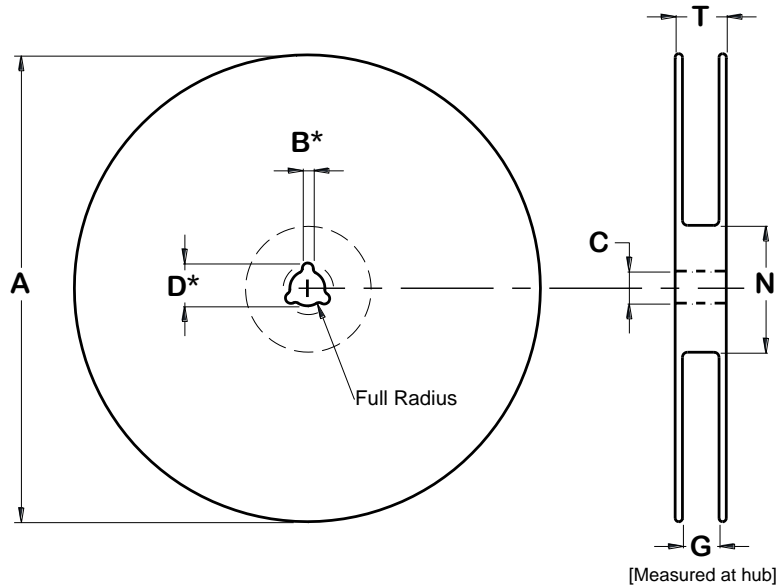

\* Drive spokes optional. If used, dimensions with asterisks apply.

Tape Width	Reel Size	A (mm)	B Max (mm)	C (mm)	D Max (mm)	N Min (mm)	G (mm)	T Max (mm)
12mm	13"	330 ±2	2.0 +0.5 -0	13 +0.5 -0.2	20.5 ±0.2	100 ±2	12.4 +2.0 -0.0	18.4

**Tape Leader and Trailer Specifications** (Notes 14 and 15)

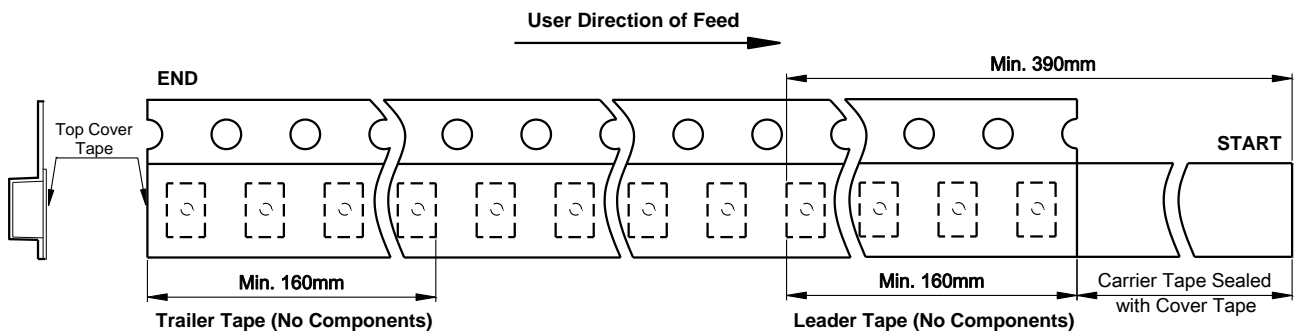

- Notes:
- 14. There shall be a leader of at least 230mm which may consist of carrier tape and/or cover tape or a start tape followed by at least 160mm of empty carrier tape sealed with cover tape.
  - 15. There shall be a trailer of at least 160mm of empty carrier tape sealed with cover tape. The entire carrier tape must release from the reel hub as the last portion of the tape unwinds from the reel without damage to the carrier tape and the remaining components in the cavities.

**IMPORTANT NOTICE**

DIODES INCORPORATED MAKES NO WARRANTY OF ANY KIND, EXPRESS OR IMPLIED, WITH REGARDS TO THIS DOCUMENT, INCLUDING, BUT NOT LIMITED TO, THE IMPLIED WARRANTIES OF MERCHANTABILITY AND FITNESS FOR A PARTICULAR PURPOSE (AND THEIR EQUIVALENTS UNDER THE LAWS OF ANY JURISDICTION).

Diodes Incorporated and its subsidiaries reserve the right to make modifications, enhancements, improvements, corrections or other changes without further notice to this document and any product described herein. Diodes Incorporated does not assume any liability arising out of the application or use of this document or any product described herein; neither does Diodes Incorporated convey any license under its patent or trademark rights, nor the rights of others. Any Customer or user of this document or products described herein in such applications shall assume all risks of such use and will agree to hold Diodes Incorporated and all the companies whose products are represented on Diodes Incorporated website, harmless against all damages.

Diodes Incorporated does not warrant or accept any liability whatsoever in respect of any products purchased through unauthorized sales channel. Should Customers purchase or use Diodes Incorporated products for any unintended or unauthorized application, Customers shall indemnify and hold Diodes Incorporated and its representatives harmless against all claims, damages, expenses, and attorney fees arising out of, directly or indirectly, any claim of personal injury or death associated with such unintended or unauthorized application.

Products described herein may be covered by one or more United States, international or foreign patents pending. Product names and markings noted herein may also be covered by one or more United States, international or foreign trademarks.

This document is written in English but may be translated into multiple languages for reference. Only the English version of this document is the final and determinative format released by Diodes Incorporated.

**LIFE SUPPORT**

Diodes Incorporated products are specifically not authorized for use as critical components in life support devices or systems without the express written approval of the Chief Executive Officer of Diodes Incorporated. As used herein:

A. Life support devices or systems are devices or systems which:

1. are intended to implant into the body, or
2. support or sustain life and whose failure to perform when properly used in accordance with instructions for use provided in the labeling can be reasonably expected to result in significant injury to the user.

B. A critical component is any component in a life support device or system whose failure to perform can be reasonably expected to cause the failure of the life support device or to affect its safety or effectiveness.

Customers represent that they have all necessary expertise in the safety and regulatory ramifications of their life support devices or systems, and acknowledge and agree that they are solely responsible for all legal, regulatory and safety-related requirements concerning their products and any use of Diodes Incorporated products in such safety-critical, life support devices or systems, notwithstanding any devices- or systems-related information or support that may be provided by Diodes Incorporated. Further, Customers must fully indemnify Diodes Incorporated and its representatives against any damages arising out of the use of Diodes Incorporated products in such safety-critical, life support devices or systems.

Copyright © 2018, Diodes Incorporated

[www.diodes.com](http://www.diodes.com)

## X-ON Electronics

Largest Supplier of Electrical and Electronic Components

*Click to view similar products for [LED Lighting Drivers](#) category:*

*Click to view products by [Diodes Incorporated](#) manufacturer:*

Other Similar products are found below :

[LV5235V-MPB-H](#) [MB39C602PNF-G-JNEFE1](#) [MIC2871YMK-T5](#) [AL1676-10BS7-13](#) [AL1676-20AS7-13](#) [AP5726WUG-7](#) [MX877RTR](#)  
[ICL8201](#) [IS31BL3228B-UTLS2-TR](#) [IS31BL3506B-TTLS2-TR](#) [AL3157F-7](#) [AP5725FDCG-7](#) [AP5726FDCG-7](#) [LV52204MTTBG](#)  
[SLG7NT4082VTR](#) [AP5725WUG-7](#) [STP4CMPQTR](#) [NCL30086BDR2G](#) [CAT4004BHU2-GT3](#) [LV52207AXA-VH](#) [AP1694AS-13](#)  
[TLE4242EJ](#) [AS3688](#) [IS31LT3172-GRLS4-TR](#) [TLD2311EL](#) [KTD2694EDQ-TR](#) [KTZ8864EJAA-TR](#) [IS32LT3174-GRLA3-TR](#)  
[ZXLD1374QESTTC](#) [AL1676-20BS7-13](#) [IS31FL3737B-QFLS4-TR](#) [IS31FL3239-QFLS4-TR](#) [KTD2058EUAC-TR](#) [KTD2037EWE-TR](#)  
[DIO5662ST6](#) [IS31BL3508A-TTLS2-TR](#) [MAX20052CATC/V+](#) [MAX25606AUP/V+](#) [BD6586MUV-E2](#) [BD9206EFV-E2](#) [BD9416FS-E2](#)  
[LYT4227E](#) [LYT6079C-TL](#) [MP3394SGF-P](#) [MP4689AGN-P](#) [MPQ4425AGQB-AEC1-Z](#) [TLD1311ELXUMA1](#) [TLE4309GATMA1](#)  
[MIC2873YCS-TR](#) [TPS92410DR](#)