

Description

The AL3565 is a Power Management Integrated Chip (PMIC) with three programmable DC-DC converters via a simple one wire digital control to power supply bias 500mA AMOLED (Active Matrix Organic Light Emitting Diode) panel requiring three supply rails, V_{POS} , V_{NEG} and AV_{DD} .

The device integrates a buck-boost converter for V_{POS} , an inverting buck-boost converter for V_{NEG} , and a boost converter for AV_{DD} , which are suitable for power management of portable products operated under lithium-ion battery power.

The PRG (Programming Digital Control) pin allows programming the V_{POS} and V_{NEG} output voltage in steps of 100mV, and AV_{DD} in steps of 300mV. The AL3565 offers an excellent line and load regulation.

The AL3565 is available in U-QFN3030-16 (Type B) (3.0mm x 3.0mm) 16-pin package with exposed pad. Please contact us for WL-CSP and other package options.

Features

- Wide Input Voltage Range: 2.9V to 4.8V
- -40°C to + 85°C Operating Ambient Temperature
- V_{POS} – Buck-Boost Converter (Default 4.6V)
 - 4.6V to 5.4V, Programmable Output Voltage
 - 100mV Step Size
 - Up to 500mA Output Current
 - 0.5% Accuracy
- AV_{DD} – Boost Converter (Default 6.1V)
 - 5.8V to 7.9V, Programmable Output Voltage
 - 300mV Step Size
 - 100mA Output Current
 - 0.5% Accuracy
- V_{NEG} – Inverting Buck-Boost Converter (Default -2.5V)
 - -1.4V to -5.4V, Programmable Negative Voltage
 - 100mV Step Size
 - Up to 500mA Output Current
 - 0.5% Accuracy
- Excellent Line and Transient Regulations
- Short-Circuit Protection (SCP)
- Thermal Shutdown Protection
- **Totally Lead-Free & Fully RoHS Compliant (Notes 1 & 2)**
- **Halogen and Antimony Free. “Green” Device (Note 3)**
- **For automotive applications requiring specific change control (i.e. parts qualified to AEC-Q100/101/104/200, PPAP capable, and manufactured in IATF 16949 certified facilities), please [contact us](mailto:contact@diodes.com) or your local Diodes representative. <https://www.diodes.com/quality/product-definitions/>**

Notes: 1. No purposely added lead. Fully EU Directive 2002/95/EC (RoHS), 2011/65/EU (RoHS 2) & 2015/863/EU (RoHS 3) compliant.
 2. See <https://www.diodes.com/quality/lead-free/> for more information about Diodes Incorporated's definitions of Halogen- and Antimony-free, "Green" and Lead-free.
 3. Halogen- and Antimony-free "Green" products are defined as those which contain <900ppm bromine, <900ppm chlorine (<1500ppm total Br + Cl) and <1000ppm antimony compounds.

Pin Assignments

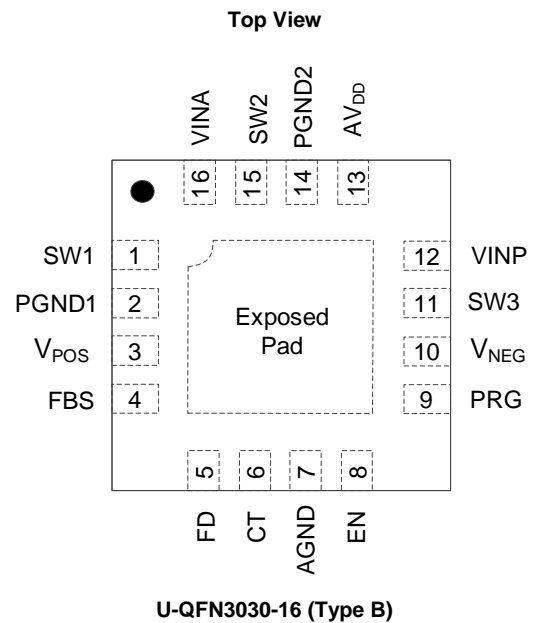

Applications

- AMOLED display panel power supply bias

Typical Applications Circuits

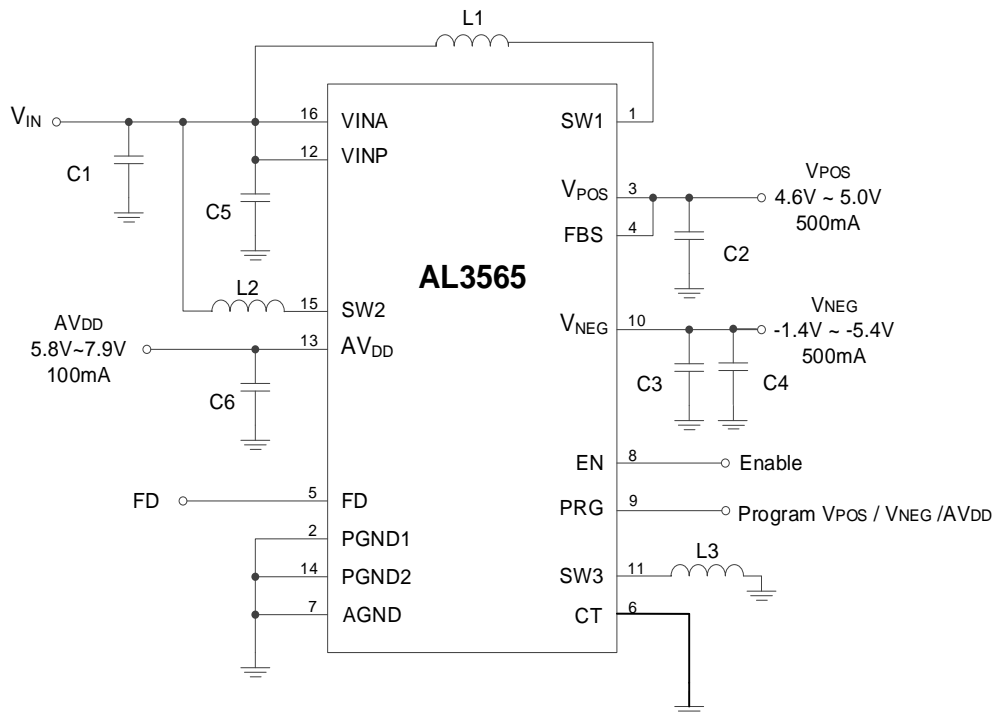

Pin Descriptions

Pin Number	Pin Name	Description
1	SW1	Boost converter switch pin
2	PGND1	Boost converter power ground
3	VPOS	Boost converter output (VPOS)
4	FBS	Boost converter sense pin
5	FD	Fast Discharge circuit function selection. High level enables the fast discharge function; low level sets VPOS, VNEG and AVDD high impedance without output.
6	CT	Must tie to ground
7	AGND	Analog ground
8	EN	Enable boost converter (AVDD)
9	PRG	Programming control pin, digital control VPOS, VNEG and AVDD output voltage
10	VNEG	Inverting buck-boost output (VNEG)
11	SW3	Inverting buck-boost switching pin
12	VINP	Inverting buck-boost converter power stage supply voltage
13	AVDD	Boost converter output voltage pin (AVDD)
14	PGND2	Boost converter power ground
15	SW2	Boost converter switching pin
16	VINA	Supply voltage for the device
—	Exposed Pad	Connect to the Ground layers on the PCB

Functional Block Diagram

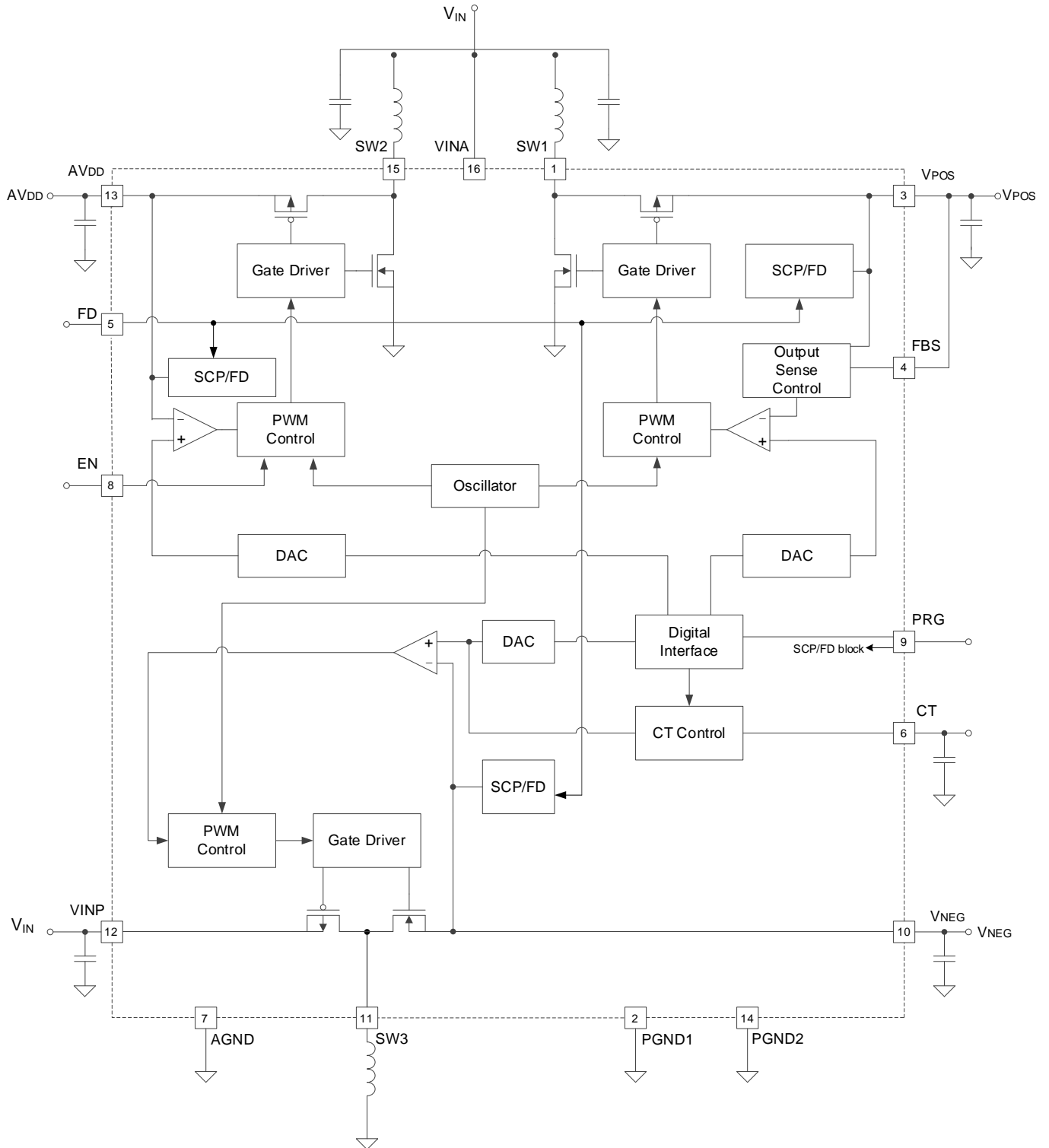

Absolute Maximum Ratings

Symbol	Parameter	Ratings	Unit
V _{INP} , V _{INA}	Supply pin voltage	-0.3 to 6.5	V
SW1	Switch pin voltage	-0.3 to 6.5	
FBS	Feedback sense pin voltage	-0.3 to 6.5	
SW2	Switch pin voltage	-0.3 to 12.0	
V _{POS}	V _{POS} pin voltage	-0.3 to 6.5	
A _{VDD}	A _{VDD} pin voltage	-0.3 to 12.0	
V _{NEG}	V _{NEG} pin voltage	-6.5 to 0.3	
SW3	Switch pin voltage	-6.5 to 6.5	
PRG, EN, FD	PRG, EN, FD pin voltage	-0.3 to 6.5	
CT	CT pin voltage	-0.3 to 6.5	
T _J	Operating junction temperature	-40 to +150	
T _{ST}	Storage temperature	-65 to +150	

Caution: Stresses greater than those listed under *Absolute Maximum Ratings* can cause permanent damage to the device. These are stress ratings only, and functional operation of the device at these or any other conditions beyond those indicated under *Recommended Operating Conditions* is not implied. Exposure to *Absolute Maximum Ratings* for extended periods can affect device reliability. Semiconductor devices are ESD sensitive and may be damaged by exposure to ESD events. Suitable ESD precautions should be taken when handling and transporting these devices.

ESD Ratings

Symbol	Parameter	Value	Unit	
V _{ESD}	Electrostatic discharge	Human body model ESD protection	±2000	V
		Charge device mode ESD protection	1000	V

Package Thermal Data

Package	θ_{JC} Thermal Resistance Junction-to-Case	θ_{JA} Thermal Resistance Junction-to-Ambient	P _{DIS} T _A = +25°C, T _J = +125°C
U-QFN3030-16 (Type B)	3.3°C/W	42.9°C/W (Note 4)	1.5W

Recommended Operating Conditions

Symbol	Parameter	Min	Max	Unit
V _{IN}	Input supply voltage range	2.9	4.8	V
T _A	Operating ambient temperature range	-40	+85	°C

Note: 4. Test condition for U-QFN3030-16 (Type B): device mounted on 25.4mm x 25.4mm FR-4 PCB (10mm x 10mm 1oz copper, minimum recommended pad layout on top layer and thermal vias to bottom layer ground plane). For better thermal performance, larger copper pad for heatsink is needed.

Electrical Characteristics ($V_{IN} = 3.7V$, $PRG = 3.7V$, $EN = 3.7V$, $V_{POS} = 4.6V$, $V_{NEG} = -2.5V$, $AV_{DD} = 6.1V$, $T_A = -40^{\circ}C$ to $+85^{\circ}C$, typical values are at $T_A = +25^{\circ}C$, unless otherwise specified.)

Symbol	Parameter	Conditions	Min	Typ	Max	Unit		
Input Supply Section								
V_{IN}	Input voltage	—	$T_A = -40^{\circ}C$ to $+85^{\circ}C$		2.9	3.7	4.8	V
V_{UVLO}	Undervoltage lockout threshold	V_{IN} falling	—	2.7	—	2.8	V	
		V_{IN} rising	—	2.75	—	2.86	V	
I_{SD}	Shutdown current	$PRG = GND$, $EN = GND$, sum of current flowing into V_{INA} and V_{INP}	—	0.3	1	μA		
V_{POS} – Boost/Buck-Boost Converter								
V_{VPOS}	V_{POS} voltage	Default voltage	—	—	4.6	—	V	
		Output accuracy	$T_A = +25^{\circ}C$, No load	-0.5	—	0.5	%	
			$T_A = -40^{\circ}C$ to $+85^{\circ}C$, No load	-0.8	—	0.8	%	
Output range (100mV/step)	—	4.6	—	5.0	V			
$R_{DS(on)1N}$	Switch on-resistance (nMOS)	$I_{(SW1)} = 200mA$	—	—	250	—	m Ω	
$R_{DS(on)1P}$	Rectifier on-resistance (pMOS)		—	—	350	—	m Ω	
f_{SW1}	Switching frequency	$I_{VPOS} = 500mA$	—	—	1.5	—	MHz	
I_{SW1}	Switch current limit	Inductor peak current	—	1.1	1.4	1.8	A	
V_{SCP_VPOS}	Short-circuit threshold in operation	Percentage of V_{POS}	—	—	90	—	%	
t_{SCP_VPOS}	Short-circuit detection time in operation	—	—	—	1	—	ms	
V_T	FBS sense threshold	FBS increasing	—	200	300	400	mV	
		FBS decreasing	—	100	200	300	mV	
R_{DCHG1}	Discharge resistance	$PRG = GND$, $FD = V_{IN}$ $I_{VPOS} = 1mA$	—	—	70	—	Ω	
V_{RIPPLE_VPOS}	V_{POS} output voltage ripple	$V_{IN} = 3.7V$, $V_{POS} = 4.6V$ $I_{POS} = 500mA$	—	—	20	—	mV	
I_{LEAK_VPOS}	V_{POS} and FBS leakage, no discharge	$FD = GND$, $PRG = GND$	$V_{POS} \leq V_{IN}$	—	0.1	—	μA	
—	Line regulation	$I_{POS} = 500mA$	—	—	0.03	—	%/V	
—	Load regulation	$V_{IN} = 3.7V$ $0mA \leq I_{POS} \leq 500mA$	$100mA \leq I_{POS} \leq 500mA$	—	0.08	—	%/A	
			$0mA \leq I_{POS} \leq 500mA$	—	0.1	—	%/A	
AV_{DD} – Boost Converter								
V_{AVDD}	V_{AVDD} voltage	Default voltage	—	—	7.6	—	V	
		Output accuracy	$T_A = +25^{\circ}C$, No load	-0.5	—	0.5	%	
			$T_A = -40^{\circ}C$ to $+85^{\circ}C$, No load	-1.0	—	1.0	%	
Output range (300mV/step)	—	5.8	—	7.9	V			
$R_{DS(on)2N}$	Switch on-resistance (nMOS)	$I_{(SW2)} = 100mA$	—	—	300	—	m Ω	
$R_{DS(on)2P}$	Rectifier on-resistance (pMOS)		—	—	450	—	m Ω	
f_{SW2}	Switching frequency	$I_{AVDD} = 100mA$	—	—	1.5	—	MHz	
V_{SCP_AVDD}	Short-circuit threshold in operation	Percentage of nominal AV_{DD}	—	—	90	—	%	
t_{SCP_AVDD}	Short-circuit detection time in operation	—	—	—	1	—	ms	
I_{SW2}	Switch current limit	Inductor peak current	—	0.45	0.65	0.85	A	
V_{RIPPLE_AVDD}	AV_{DD} output voltage ripple	$V_{IN} = 3.7V$, $AV_{DD} = 7.6V$ $I_{AVDD} = 100mA$	—	—	20	—	mV	
I_{LEAK_AVDD}	AV_{DD} leakage, no discharge	$FD = GND$, $EN = GND$	$AV_{DD} \leq V_{IN}$	—	0.3	—	μA	
R_{DCHG2}	Discharge resistance	$EN = GND$, $FD = V_{IN}$ $I_{AVDD} = 1mA$	—	—	70	—	Ω	
—	Line regulation	$I_{AVDD} = 30mA$	—	—	0.05	—	%/V	
—	Load regulation	$0mA \leq I_{AVDD} \leq 100mA$	$50mA \leq I_{AVDD} \leq 100mA$	—	0.5	—	%/A	
			$0mA \leq I_{AVDD} \leq 100mA$	—	0.5	—	%/A	

Electrical Characteristics ($V_{IN} = 3.7V$, $PRG = 3.7V$, $EN = 3.7V$, $V_{POS} = 4.6V$, $V_{NEG} = -2.5V$, $AV_{DD} = 6.1V$, $T_A = -40^{\circ}C$ to $+85^{\circ}C$, typical values are at $T_A = +25^{\circ}C$, unless otherwise specified.) (continued)

Symbol	Parameter	Conditions	Min	Typ	Max	Unit	
VNEG – Inverting Buck-Boost Converter							
V_{VNEG}	V_{VNEG} voltage	Default voltage	—	-4.0	—	V	
		Output accuracy	$T_A = +25^{\circ}C$	-0.5	—	0.5	%
			$T_A = -40^{\circ}C$ to $+85^{\circ}C$	-0.8	—	0.8	%
	Output range (100mV/step)	—	-1.4	—	-5.4	V	
$R_{DS(on)3P}$	Switch on-resistance (pMOS)	$I_{(SW3)} = 200mA$	—	200	—	m Ω	
$R_{DS(on)3N}$	Rectifier on-resistance (nMOS)		—	300	—	m Ω	
f_{SW3}	Switching frequency	$I_{NEG} = 500mA$	—	1.5	—	MHz	
I_{SW3}	Switch current limit	Inductor peak current	—	1.5	2.0	2.75	A
V_{SCP_VNEG}	Short-circuit threshold in operation	Voltage increase from nominal V_{NEG}	—	530	—	mV	
	Short-circuit threshold in startup	—	—	250	—	mV	
t_{SCP_VNEG}	Short-circuit detection time in operation	—	—	1	—	ms	
	Short-circuit detection time in startup	—	—	10	—	ms	
I_{LEAK_VNEG}	V_{NEG} leakage, no discharge	$FD = GND$, $EN = GND$	$V_{NEG} = 0V$	—	0.1	—	μA
V_{RIPPLE_VNEG}	V_{NEG} output voltage ripple	$V_{IN} = 3.7V$, $V_{NEG} = -4.0V$ $I_{AVDD} = 500mA$	—	20	—	mV	
R_{DCHG3}	Discharge resistance	$PRG = GND$, $FD = V_{IN}$ $I_{VNEG} = 1mA$	—	70	—	Ω	
—	Line regulation	$I_{NEG} = 500mA$	—	0.03	—	%/V	
—	Load regulation	$V_{NEG} = -5V$ $1mA \leq I_{NEG} \leq 500mA$	$100mA \leq I_{NEG} \leq 500mA$	—	1.6	—	%A
			$1mA \leq I_{NEG} \leq 500mA$	—	2.0	—	
Logic Interface (PRG, EN, FD)							
V_{IH}	Logic input high level voltage	—	—	1.2	—	V	
V_{IL}	Logic input low level voltage	—	—	—	0.4	V	
R	Pulldown resistance	—	—	250	500	900	k Ω
Other							
T_{SHDN}	Thermal shutdown	Junction temperature	—	+150	—	$^{\circ}C$	
T_{HYS}	Thermal shutdown hysteresis	—	—	+10	—	$^{\circ}C$	
PRG Timing Interface Section (PRG, EN, FD)							
t_{INIT}	Initialization time	—	—	300	—	μs	
t_{STORE}	Data storage time	—	30	—	80	μs	
t_{LOW}	Low-level pulse duration	—	2	10	25	μs	
t_{HIGH}	High-level pulse duration	—	2	10	25	μs	
t_{OFF}	Shutdown time	—	30	—	80	μs	

Performance Characteristics ($V_{IN} = 3.7V$, $T_A = +25^{\circ}C$ with components as Figure 20, unless otherwise specified.)

Test conditions: $AV_{DD} = 7.6V$, $EN = HIGH$, $PRG = LOW$

$V_{POS} = 4.6V$, $V_{NEG} = -4V$, $EN = LOW$, $PRG = HIGH$

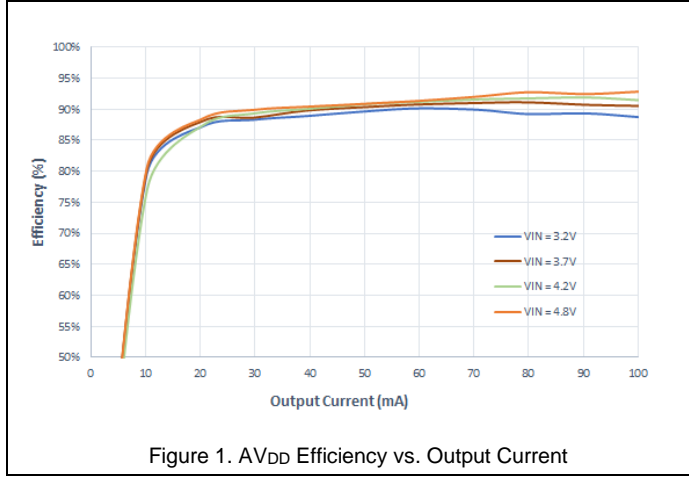

Figure 1. AV_{DD} Efficiency vs. Output Current

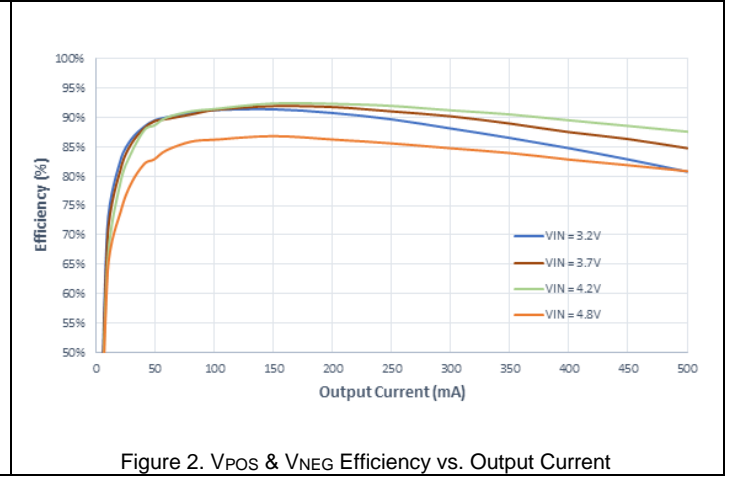

Figure 2. V_{POS} & V_{NEG} Efficiency vs. Output Current

Test conditions: $V_{IN} = 3.7V$, No Load, $PRG = HIGH$, $EN = LOW$

$V_{IN} = 3.7V$, No Load, $PRG = LOW$, $EN = HIGH$

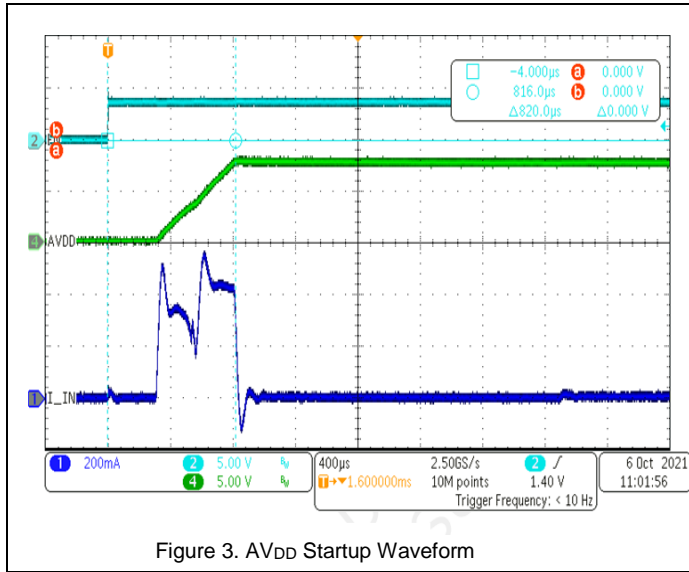

Figure 3. AV_{DD} Startup Waveform

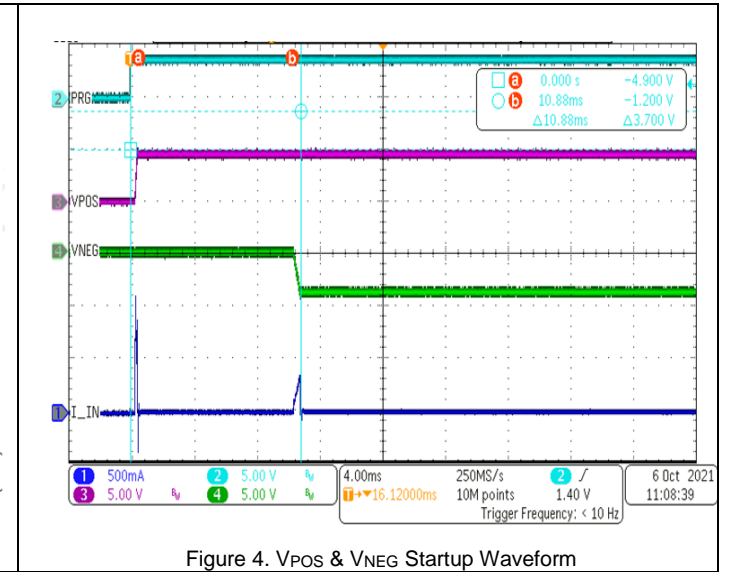

Figure 4. V_{POS} & V_{NEG} Startup Waveform

Test conditions: V_{POS} V_{NEG} with Fast Discharge (FD) = OFF

V_{POS} V_{NEG} with Fast Discharge (FD) = ON

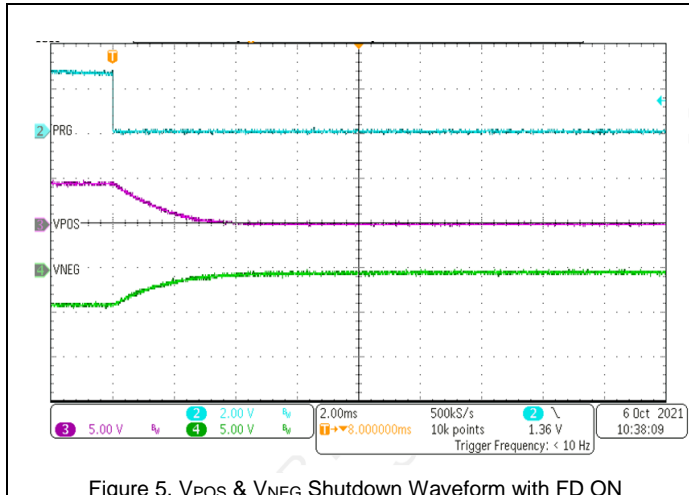

Figure 5. V_{POS} & V_{NEG} Shutdown Waveform with FD ON

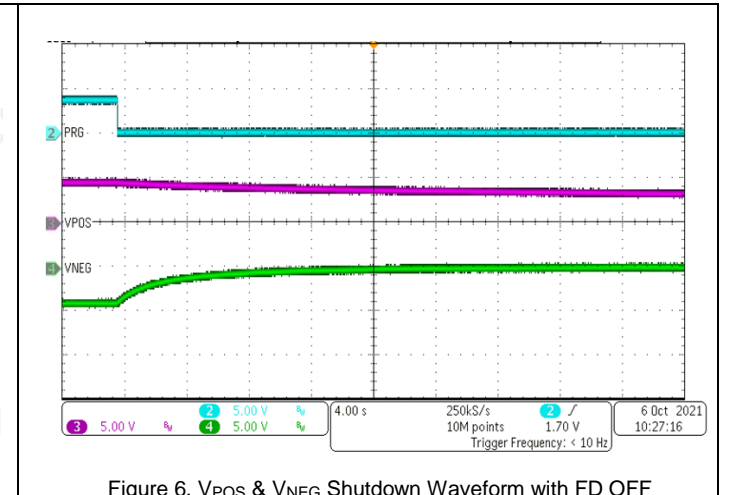

Figure 6. V_{POS} & V_{NEG} Shutdown Waveform with FD OFF

Performance Characteristics ($V_{IN} = 3.7V$, $T_A = +25^\circ C$ with components as Figure 20, unless otherwise specified.) (continued)

Test conditions: V_{POS} Boost, $V_{POS} = 4.6V / 100mA$ load

V_{POS} Boost, $V_{POS} = 4.6V / 300mA$ load

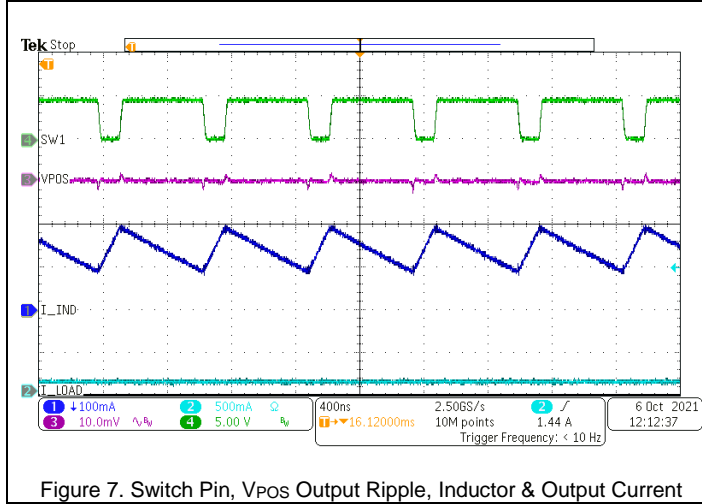

Figure 7. Switch Pin, V_{POS} Output Ripple, Inductor & Output Current

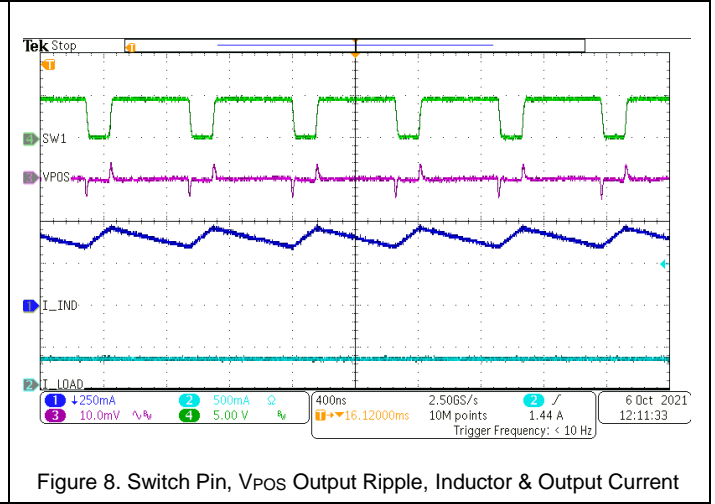

Figure 8. Switch Pin, V_{POS} Output Ripple, Inductor & Output Current

Test conditions: V_{POS} Boost, $V_{POS} = 4.6V / 500mA$ load

$V_{NEG} = -4.0V / 100mA$ load

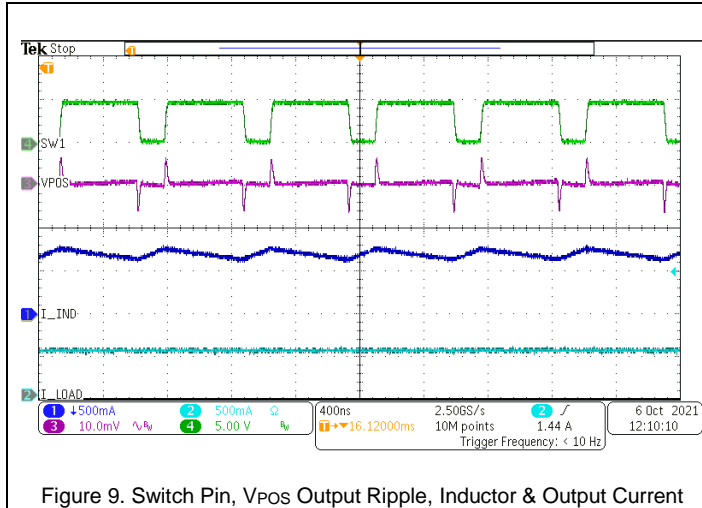

Figure 9. Switch Pin, V_{POS} Output Ripple, Inductor & Output Current

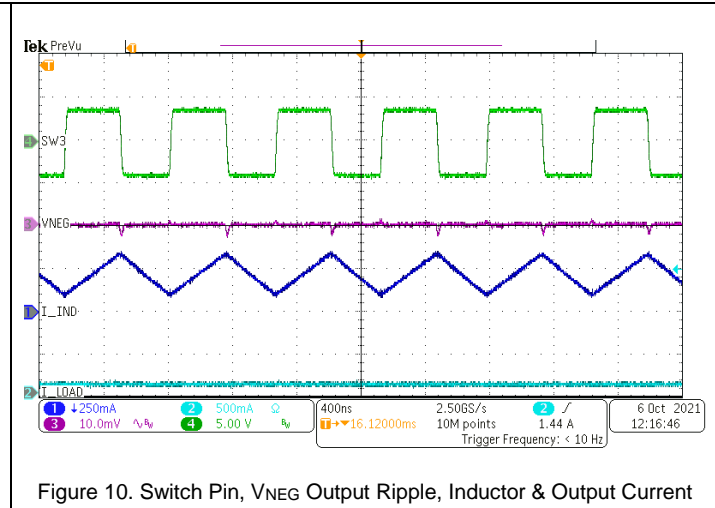

Figure 10. Switch Pin, V_{NEG} Output Ripple, Inductor & Output Current

Test conditions: $V_{NEG} = -4.0V / 300mA$ load

$V_{NEG} = -4.0V / 500mA$ load

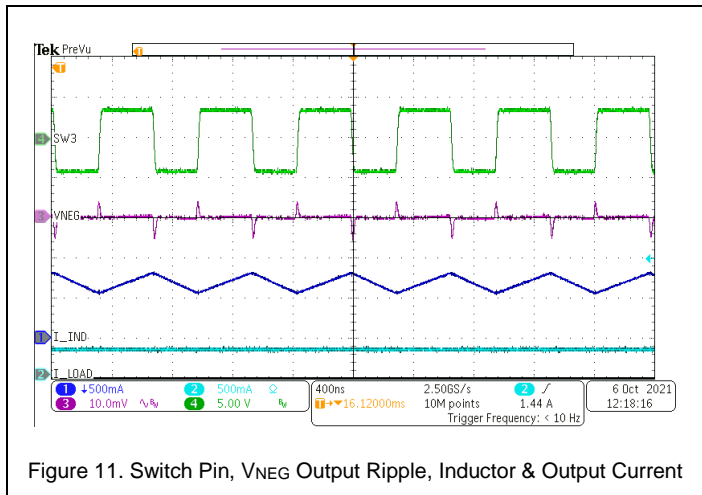

Figure 11. Switch Pin, V_{NEG} Output Ripple, Inductor & Output Current

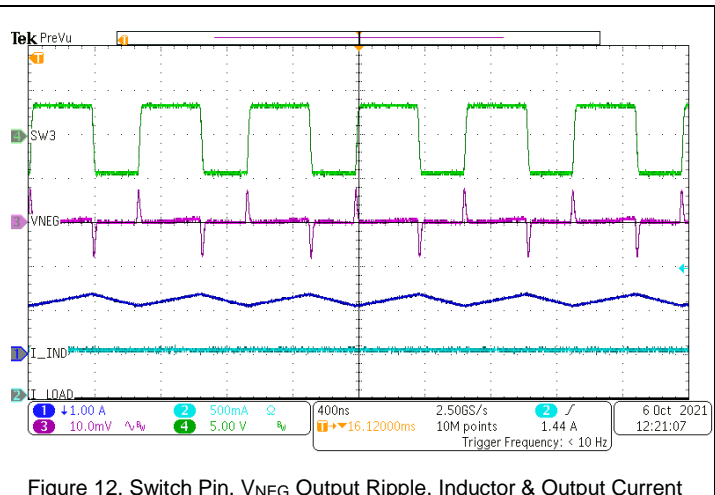

Figure 12. Switch Pin, V_{NEG} Output Ripple, Inductor & Output Current

Performance Characteristics ($V_{IN} = 3.7V$, $T_A = +25^\circ C$ with components as Figure 20, unless otherwise specified.) (continued)

Test conditions: $AV_{DD} = 7.6V / 50mA$ load

$AV_{DD} = 7.6V / 100mA$ load

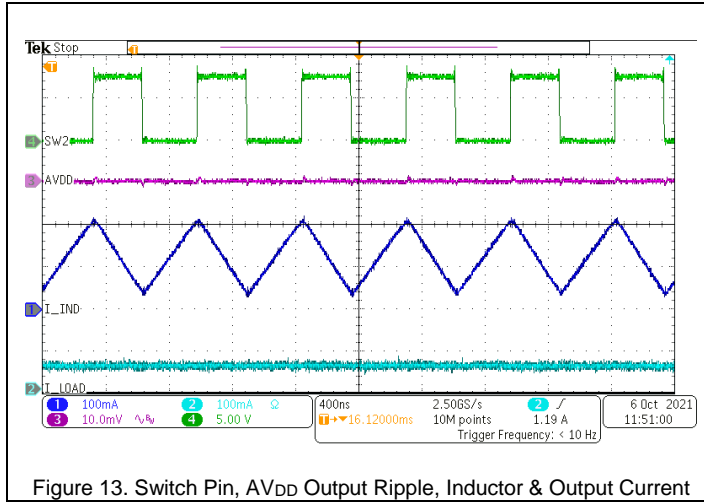

Figure 13. Switch Pin, AV_{DD} Output Ripple, Inductor & Output Current

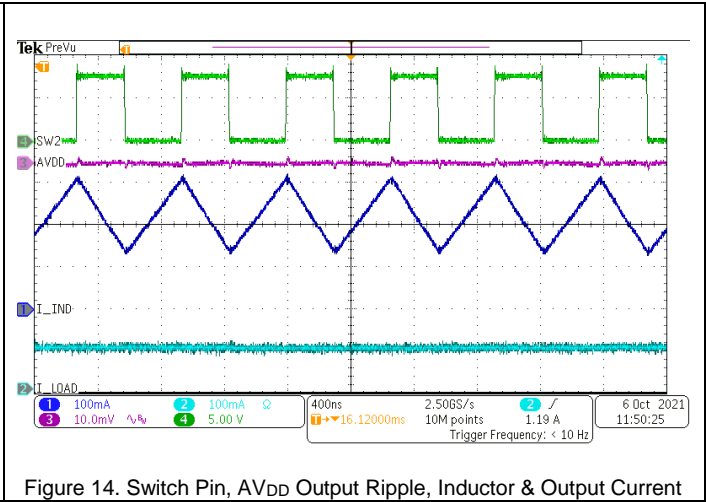

Figure 14. Switch Pin, AV_{DD} Output Ripple, Inductor & Output Current

Function Description

The AL3565 consists of two boost converters and an inverting buck-boost converter. The V_{POS} , V_{NEG} and AV_{DD} outputs are all programmable through the PRG digital pin. The V_{POS} output range is from 4.6V to 5.0V, default 4.6V. The V_{NEG} output range is from -5.4V to -1.4V, default -2.5V. The AV_{DD} output range is from 5.8V to 7.9V, default 6.1V. Fast discharge function is on/off controlled by FD pin

1.0 Startup Sequence, Soft-Start and Shutdown

The device features a soft-start function to limit the inrush current. The AV_{DD} boost converter is enabled when EN goes high. When PRG goes high, the V_{POS} boost/buck-boost converter starts and 10ms later the inverting buck-boost converter (V_{NEG}) starts with its default value. The typical startup sequence with fast discharge is shown in Figure 15. The AV_{DD} boost converter, and the V_{POS} boost converter operate independently. The AV_{DD} boost converter does not require the V_{POS} boost converter to be in regulation in order for it to start.

Before the first startup, the output discharge is undefined and the output discharge is activated by PRG rising edge, following the FD configuration. When the converters shut down, the outputs are discharged if FD function is enabled or the outputs are high impedance if FD function is disabled.

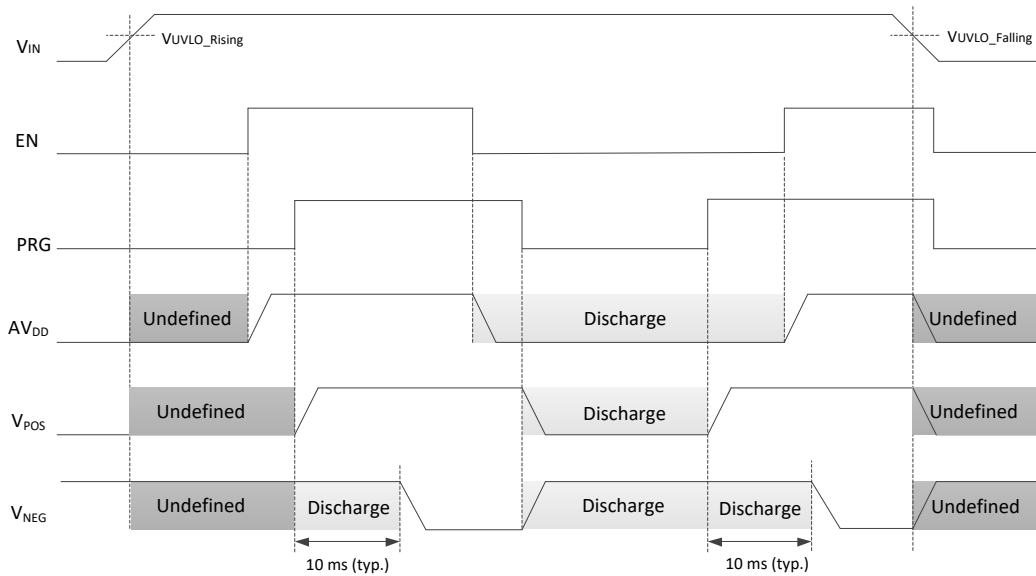

Figure 15. Startup and Shutdown Sequence with Fast Discharge

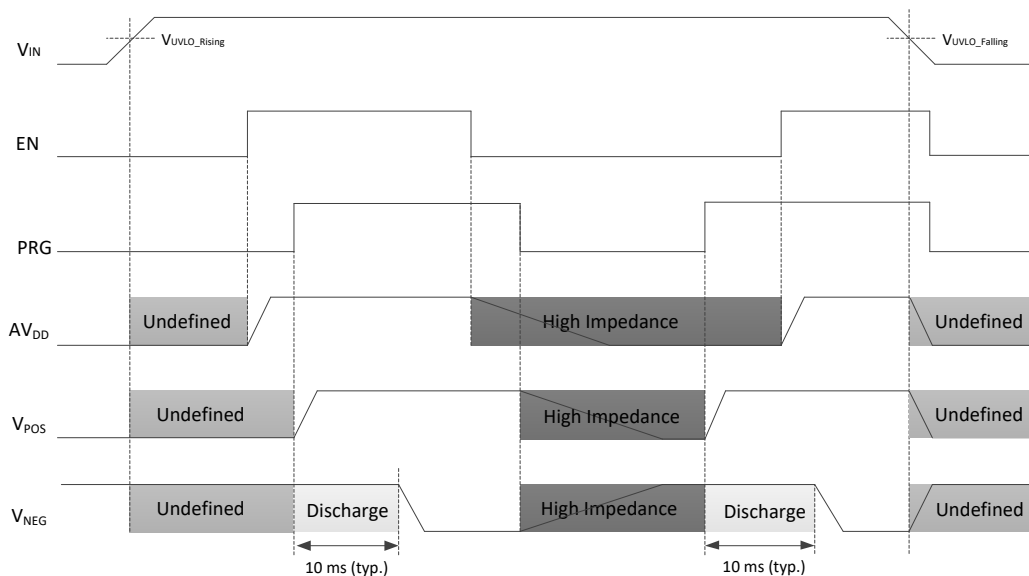

Figure 16. Startup and Shutdown Sequence Without Fast Discharge

Function Description (continued)

1.1 Programming V_{POS}, V_{NEG} and AV_{DD} Output Voltage through PRG Pin

All the output voltage of AL3565 can be programmed through PRG pin. If programming is not required the PRG pin can also be used as a standard enable pin. Once the device is enabled, AL3565 starts with its default values. The interface counts the rising edges applied to the PRG pin and sets the new values. Table 1 to 3 listed the mapping for the rising edge numbers and the corresponding the output voltage.

The settings are stored in a volatile memory, they are reset as follows:

- A power cycle resets all settings to default values.
- Enabling the V_{POS} boost/buck-boost converter sets the output discharge. (The output discharge function is controlled by FD pin.)
- If PRG is low for a min. t_{OFF}, V_{NEG} will be reset to default value and V_{POS} will be reset to default value.
- If EN and PRG are low at the same time for min. t_{OFF}, AV_{DD} will be reset to its default value. If EN is low and PRG is high, AV_{DD} retains its programmed value.

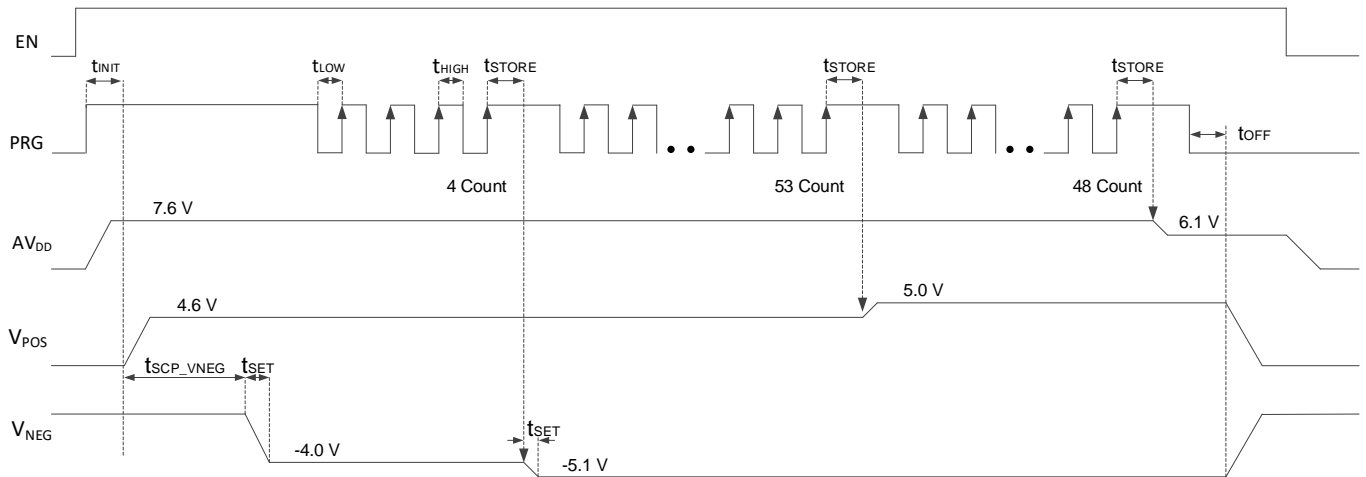

Figure 17. Digital Interface Using PRG Pin

Function Description (continued)

2.0 V_{POS} – Boost/Buck-Boost Converter

The boost/buck-boost converter V_{POS} uses a fixed-frequency current-mode topology. Its default output voltage V_{POS} is (4.6V) for AL3565. V_{POS} can be programmed through the digital PRG pin. For higher output voltage accuracy, connect the output sense pin (FBS) directly to the positive terminal of the main output capacitor. If not used, the FBS pin shall be tied to ground.

2.1 V_{POS} – Asynchronous Buck-Boost Mode

When V_{POS} is close to V_{IN}, AL3565 enters asynchronous buck-boost mode. In this mode, the high-side power pMOS channel is turned off completely and the power pMOS body diode is used for the conduction.

2.2 V_{POS} – Boost Converter, Output Sense (FBS pin)

The positive output boost circuitry has a dedicated output pin (FBS). If FBS is floating or tied to ground, the positive output boost circuitry senses the output through the V_{POS} pin.

2.3 V_{POS} Voltage Control by PRG Pin

When the PRG pin is pulled high while the device is enabled, V_{POS} will rise to its default voltage of 4.6V. While the device is enabled, the digital programming interface counts the number of rising edges applied to the PRG pin. Table 1 shows the pulse count for a corresponding programmed V_{POS} voltage. V_{POS} can be programmed in 100mV steps.

Bit / Rising Edges	V _{POS}
Default	4.6V
54	4.7V
55	4.8V
56	4.9V
57	5.0V
64	4.6V

Table 1. Programing Table for AL3565 V_{POS}

Function Description (continued)

3.0 AV_{DD} – Boost Converter

Boost converter uses a fixed-frequency current-mode topology. Its default output voltage AV_{DD} is (6.1V) for AL3565. AV_{DD} can be programmed through the digital PRG pin.

3.1 AV_{DD} Voltage Control by PRG Pin

Once the device is enabled using the EN pin, AV_{DD} will rise to its default value. While the device is enabled, the digital programming interface counts the number of rising edges applied to the PRG pin. Table 2 shows the pulse count for a corresponding programmed AV_{DD} voltage. AV_{DD} can be programmed in 300mV steps.

Bit / Rising Edges	AV _{DD}
Default	7.6V
42	7.9V
43	7.6V
44	7.3V
45	7.0V
46	6.7V
47	6.4V
48	6.1V
49	5.8V

Table 2. Programing Table for AL3565 AV_{DD}

Function Description (continued)

4.0 V_{NEG} – Inverting Buck-Boost Converter

The inverting buck-boost converter uses a peak current PWM control topology. Its default output voltage V_{NEG} is (-2.5V) for AL3565. V_{NEG} can be programmed through the digital PRG pin.

4.1 V_{NEG} Voltage Control by PRG Pin

When the PRG pin is pulled high while the device is enabled, V_{NEG} will fall to its default value. While the device is enabled, the digital programming interface counts the number of rising edges applied to the PRG pin. Table 3 shows the pulse count for a corresponding programmed V_{NEG} voltage. V_{NEG} can be programmed in 100mV steps.

Bit / Rising Edges	V _{NEG}	Bit / Rising Edges	V _{NEG}
Default	-4.0V	21	-3.4V
1	-5.4 V	22	-3.3V
2	-5.3 V	23	-3.2V
3	-5.2 V	24	-3.1V
4	-5.1V	25	-3.0V
5	-5.0V	26	-2.9V
6	-4.9V	27	-2.8V
7	-4.8V	28	-2.7V
8	-4.7V	29	-2.6V
9	-4.6V	30	-2.5V
10	-4.5V	31	-2.4V
11	-4.4V	32	-2.3V
12	-4.3V	33	-2.2V
13	-4.2V	34	-2.1V
14	-4.1V	35	-2.0V
15	-4.0V	36	-1.9V
16	-3.9V	37	-1.8V
17	-3.8V	38	-1.7V
18	-3.7V	39	-1.6V
19	-3.6V	40	-1.5V
20	-3.5V	41	-1.4V

Table 3. Programing Table for AL3565 V_{NEG}

Function Description (continued)

5.0 FD Control

When PRG is pulled high, the fast discharge (FD) function will be initialized to its default state according to the FD pin. If the FD pin is connected to GND, fast discharge is disabled and all outputs are high impedance. If the FD pin is connected to HIGH (HIGH > 1.2V), fast discharge is enabled and all outputs are discharged.

The fast discharge function can also be controlled through the PRG pin, which would override the FD pin connection setting. Table 4 shows the pulse rising edges count for a corresponding programmed FD function (ON/OFF).

Bit / Rising Edges	FD Pin	FD	Comment
Default / 0	HIGH	ON	Using FD pin
	GND	OFF	Using FD pin
50	X	ON	Using PRG pin
51	X	OFF	Using PRG pin

Table 4. Programming Table for FD Control

Only in the “Yellow Highlighted” area, we can use pulses applied to PRG pin to disable/enable fast discharge, no matter how FD pin is configured. As shown, V_{NEG} always needs Fast Discharge active at power-up.

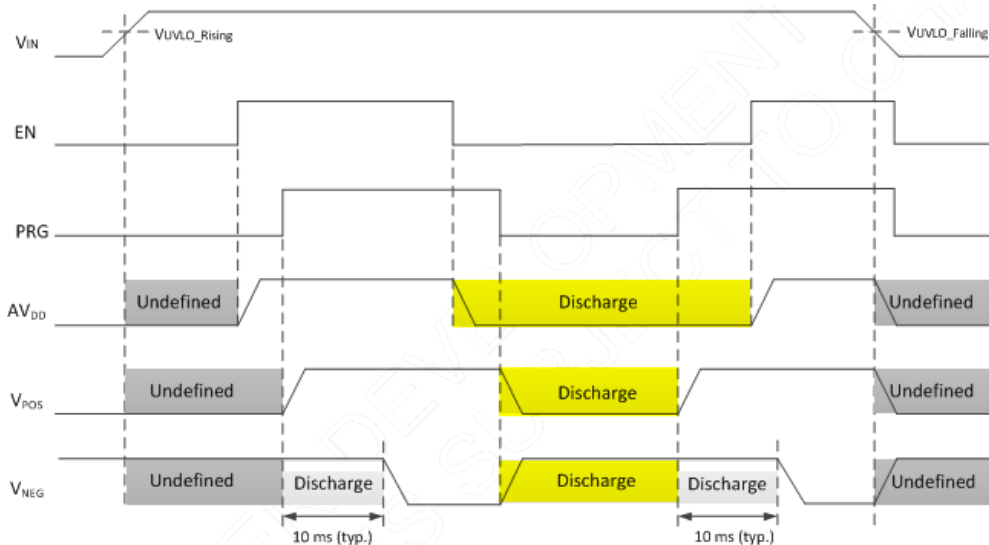

Figure 18. Fast Discharge sequence with FD = high, but discharge can be disabled by PRG (Table 4) in yellow highlighted area

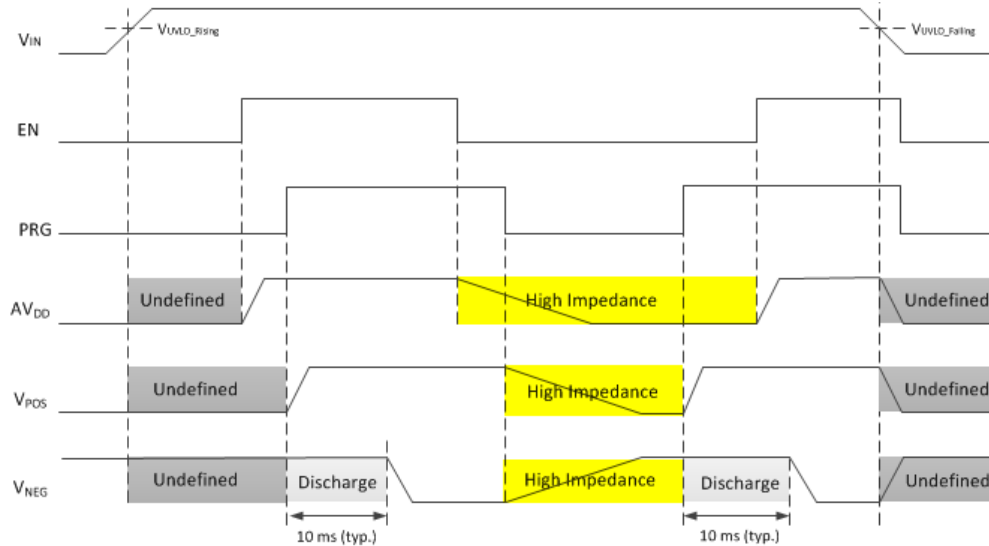

Figure 19. Without Fast Discharge sequence with FD = low, but discharge can be enabled by PRG (Table 4) in yellow highlighted area

Function Description (continued)

6.0 Short-Circuit Protection (SCP)

AL3565 detects short and shuts down in one of the below conditions:

- V_{DD} falls below 90% of its programmed voltage for more than 1ms after power-up: shutdown $V_{POS}/V_{NEG}/V_{DD}$
- V_{POS} falls below 90% of its programmed voltage for more than 1ms after power-up: shutdown $V_{POS}/V_{NEG}/V_{DD}$
- V_{NEG} rises above 500mV of its programmed voltage longer than 1ms: shutdown $V_{POS}/V_{NEG}/V_{DD}$
- $V_{NEG} > 200\text{mV}$ (during startup) when V_{NEG} is enabled (10ms after PRG = HIGH): shutdown V_{POS} and V_{NEG} only

The shutdown state is latched, and the input and outputs are disconnected. To restart the device, V_{IN} must cycle below UVLO or EN and PRG have to be low at the same time for 80 μs (t_{OFF} max spec) or longer.

See Section 7 – *Inductor/Capacitor Selection* for recommended inductor & capacitor values.

6.1 Thermal Shutdown

The AL3565 device enters thermal shutdown if its junction temperature exceeds +150°C (typical). During thermal shutdown none of the device's functions are available, but the programming data is not lost. When the temperature decreases to +140°C (typical), the device automatically restarts performing the startup sequencing with the same voltages and programming as programmed before the thermal shutdown.

Application Information

7.0 Inductor/Capacitor Selection

The AL3565 is designed for supplying power to AMOLED display in smart phone applications. The circuit inputs power from a single-cell Li-ion battery and generates an adjustable power supply AV_{DD}, an adjustable positive output voltage V_{POS} and an adjustable negative output voltage V_{NEG}.

The AV_{DD} boost converter typically requires a 10μH inductor, V_{POS} and V_{NEG} require a 4.7μH. The input and output capacitors are usually ceramic capacitors. Table 5 lists the recommended component for typical circuit configurations. Please contact us for any further components optimizations on either efficiency or sizes.

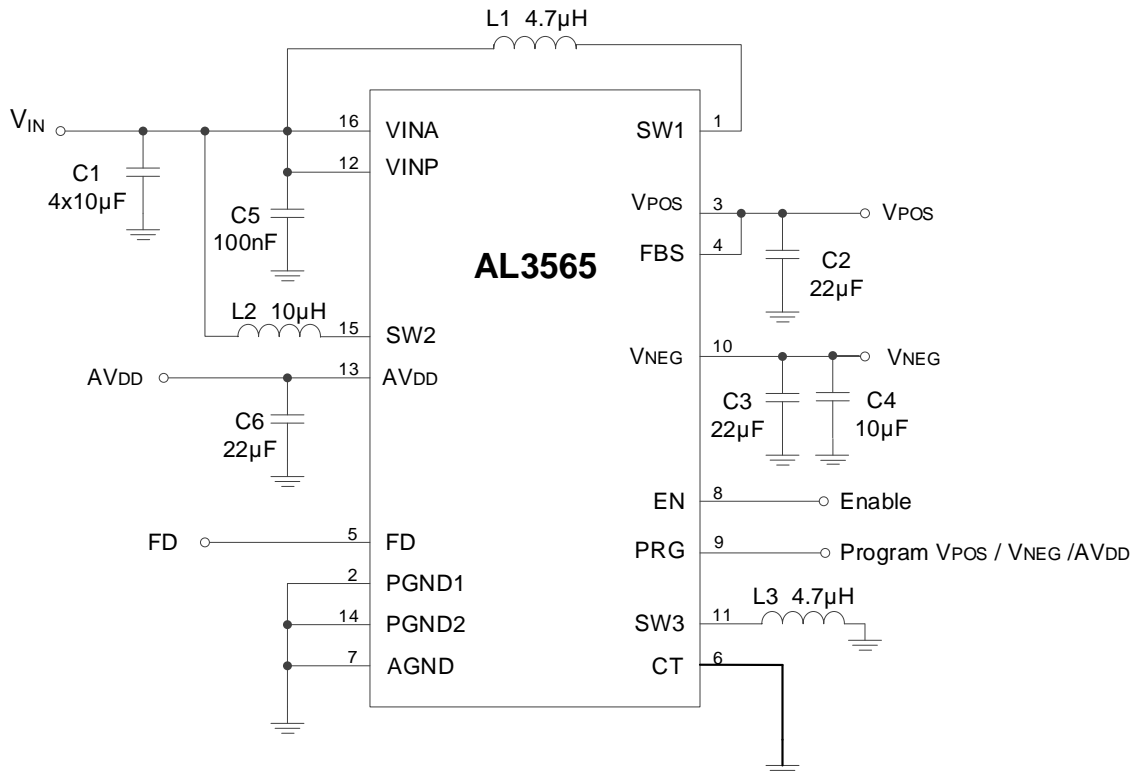

Figure 20. Typical Application Circuit

The AL3565 is designed to operate with the input voltage ranging from 2.9V to 4.8V. If the input supply is located more than a few centimeters from the AL3565, additional bulk capacitors may be needed. The (4) 10μF (C1) capacitors shown in the typical application circuit are a common choice.

Component	Designator	Value	Part Number	Manufacturer
AV _{DD} inductor	L2	10μH±20%	DFE252012C-100M	TOKO
V _{POS} and V _{NEG} inductor	L1, L3	4.7μH±20%	DFE252012F-4R7M	muRata
			DFE252012P-4R7N	TOKO
V _{IN} capacitor	C1	10μF±20% / 10V / 0805	GRM219R61A106ME47	muRata
AV _{DD} capacitor	C6	22μF±20% / 25V / 0805	CL21A226MPCLRNC	muRata
V _{POS} capacitor	C2	22μF±20% / 25V / 0805	CL21A226MPCLRNC	muRata
V _{NEG} capacitor	C3, C4	22μF±20% / 25V / 0805 10μF±20% / 25V / 0805	CL21A226MPCLRNC	muRata
			GRM219R61A106ME47	

Table 5. Component Selection Table

Application Information (continued)

8.0 Layout Guidelines

1. Place the input capacitor on V_{INP} and the output capacitor on V_{NEG} as close as possible to device. Use short and wide traces to connect the input capacitor on V_{INP} and the output capacitor on V_{NEG} .
2. Place the output capacitor on V_{POS} and AV_{DD} as close as possible to device. Use short and wide traces to connect the output capacitor on V_{POS} and AV_{DD} .
3. Connect the ground of CT capacitor with AGND (pin 7) directly.
4. Connect input ground and output ground on the same board layer, not through via hole.
5. Connect AGND, PGND1 and PGND2 with exposed thermal pad.

8.1 Layout Example

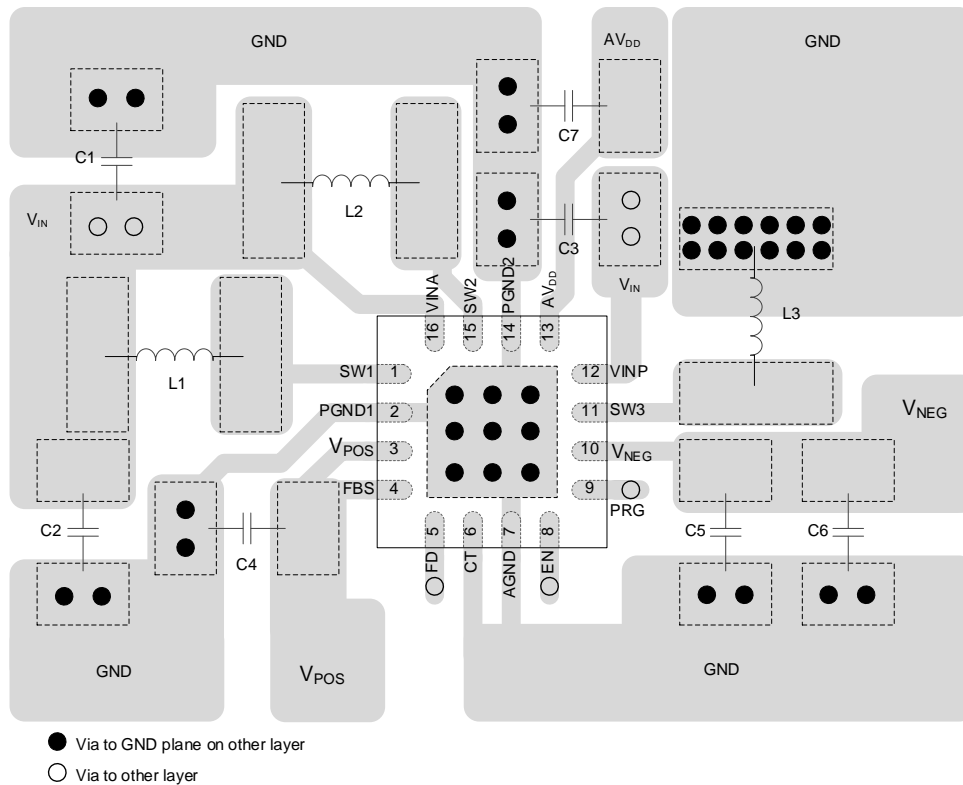

Figure 21. Recommended PCB Layout

Design Tools

- Demo Board
- Calculator
- Demo Board Gerber File of PCB Layout Reference
- PSPICE

Ordering Information

AL3565 DA-7

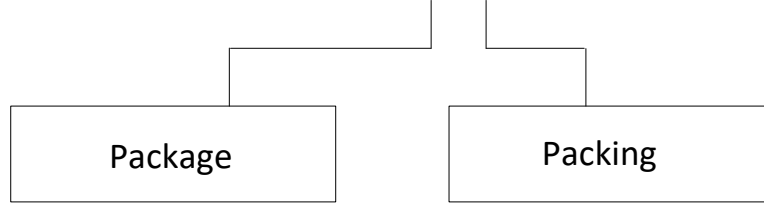

DA : U-QFN3030-16 (Type B)

7 : Tape & Reel

Part Number	Part Number Suffix	Package Code	Package (Note 5)	Packing	
				Qty.	Carrier
AL3565DA-7	-7	DA	U-QFN3030-16 (Type B)	1,500	Tape & Reel

Note: 5. For packaging details, go to our website at <https://www.diodes.com/design/support/packaging/diodes-packaging/>.

Marking Information

U-QFN3030-16 (Type B)
(Top View)

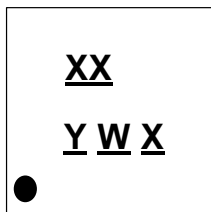

- XX : Identification Code
- Y : Year : 0 to 9 (ex: 3 = 2023)
- W : Week : A to Z : week 1 to 26;
a to z : week 27 to 52;
z represents week 52 and 53
- X : A to G : Green

Part Number	Package	Identification Code
AL3565DA-7	U-QFN3030-16 (Type B)	S9

Package Outline Dimensions

Please see <http://www.diodes.com/package-outlines.html> for the latest version.

U-QFN3030-16 (Type B)

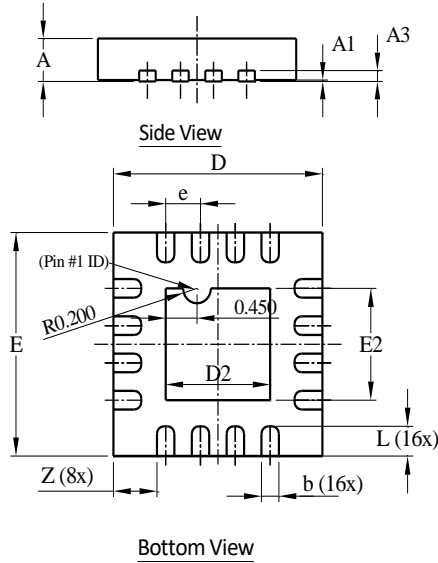

U-QFN3030-16 Type B			
Dim	Min	Max	Typ
A	0.55	0.65	0.60
A1	0	0.05	0.02
A3	-	-	0.15
b	0.18	0.28	0.23
D	2.95	3.05	3.00
D2	1.40	1.60	1.50
E	2.95	3.05	3.00
E2	1.40	1.60	1.50
e	-	-	0.50
L	0.35	0.45	0.40
Z	-	-	0.625
All Dimensions in mm			

Suggested Pad Layout

Please see <http://www.diodes.com/package-outlines.html> for the latest version.

U-QFN3030-16 (Type B)

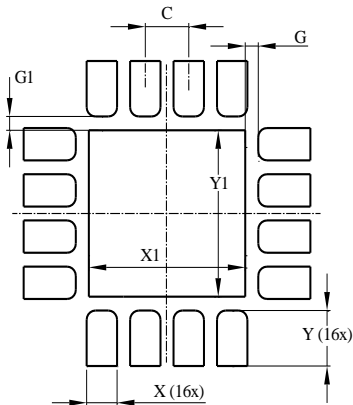

Dimensions	Value (in mm)
C	0.500
G	0.150
G1	0.150
X	0.350
X1	1.800
Y	0.600
Y1	1.800

Mechanical Data

- Moisture Sensitivity: Level 1 per JESD22-A113
- Terminals: Finish - Preplated NiPdAu, Solderable per JESD22-B102 Ⓞ4
- Weight: 0.017 grams (Approximate)

Taping Orientation

The taping orientation of other package type can be found on our website at <https://www.diodes.com/assets/Packaging-Support-Docs/ap02007.pdf>.

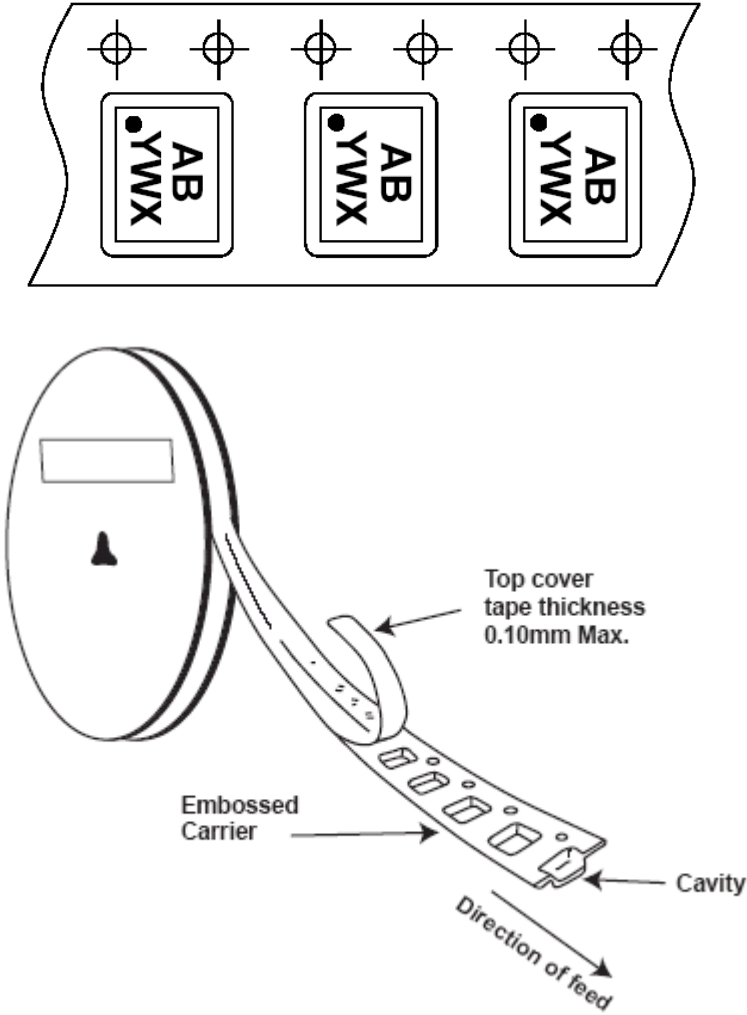

IMPORTANT NOTICE

1. DIODES INCORPORATED (Diodes) AND ITS SUBSIDIARIES MAKE NO WARRANTY OF ANY KIND, EXPRESS OR IMPLIED, WITH REGARDS TO ANY INFORMATION CONTAINED IN THIS DOCUMENT, INCLUDING, BUT NOT LIMITED TO, THE IMPLIED WARRANTIES OF MERCHANTABILITY, FITNESS FOR A PARTICULAR PURPOSE OR NON-INFRINGEMENT OF THIRD PARTY INTELLECTUAL PROPERTY RIGHTS (AND THEIR EQUIVALENTS UNDER THE LAWS OF ANY JURISDICTION).
2. The Information contained herein is for informational purpose only and is provided only to illustrate the operation of Diodes' products described herein and application examples. Diodes does not assume any liability arising out of the application or use of this document or any product described herein. This document is intended for skilled and technically trained engineering customers and users who design with Diodes' products. Diodes' products may be used to facilitate safety-related applications; however, in all instances customers and users are responsible for (a) selecting the appropriate Diodes products for their applications, (b) evaluating the suitability of Diodes' products for their intended applications, (c) ensuring their applications, which incorporate Diodes' products, comply the applicable legal and regulatory requirements as well as safety and functional-safety related standards, and (d) ensuring they design with appropriate safeguards (including testing, validation, quality control techniques, redundancy, malfunction prevention, and appropriate treatment for aging degradation) to minimize the risks associated with their applications.
3. Diodes assumes no liability for any application-related information, support, assistance or feedback that may be provided by Diodes from time to time. Any customer or user of this document or products described herein will assume all risks and liabilities associated with such use, and will hold Diodes and all companies whose products are represented herein or on Diodes' websites, harmless against all damages and liabilities.
4. Products described herein may be covered by one or more United States, international or foreign patents and pending patent applications. Product names and markings noted herein may also be covered by one or more United States, international or foreign trademarks and trademark applications. Diodes does not convey any license under any of its intellectual property rights or the rights of any third parties (including third parties whose products and services may be described in this document or on Diodes' website) under this document.
5. Diodes' products are provided subject to Diodes' Standard Terms and Conditions of Sale (<https://www.diodes.com/about/company/terms-and-conditions/terms-and-conditions-of-sales/>) or other applicable terms. This document does not alter or expand the applicable warranties provided by Diodes. Diodes does not warrant or accept any liability whatsoever in respect of any products purchased through unauthorized sales channel.
6. Diodes' products and technology may not be used for or incorporated into any products or systems whose manufacture, use or sale is prohibited under any applicable laws and regulations. Should customers or users use Diodes' products in contravention of any applicable laws or regulations, or for any unintended or unauthorized application, customers and users will (a) be solely responsible for any damages, losses or penalties arising in connection therewith or as a result thereof, and (b) indemnify and hold Diodes and its representatives and agents harmless against any and all claims, damages, expenses, and attorney fees arising out of, directly or indirectly, any claim relating to any noncompliance with the applicable laws and regulations, as well as any unintended or unauthorized application.
7. While efforts have been made to ensure the information contained in this document is accurate, complete and current, it may contain technical inaccuracies, omissions and typographical errors. Diodes does not warrant that information contained in this document is error-free and Diodes is under no obligation to update or otherwise correct this information. Notwithstanding the foregoing, Diodes reserves the right to make modifications, enhancements, improvements, corrections or other changes without further notice to this document and any product described herein. This document is written in English but may be translated into multiple languages for reference. Only the English version of this document is the final and determinative format released by Diodes.
8. Any unauthorized copying, modification, distribution, transmission, display or other use of this document (or any portion hereof) is prohibited. Diodes assumes no responsibility for any losses incurred by the customers or users or any third parties arising from any such unauthorized use.
9. This Notice may be periodically updated with the most recent version available at <https://www.diodes.com/about/company/terms-and-conditions/important-notice>

The Diodes logo is a registered trademark of Diodes Incorporated in the United States and other countries.
All other trademarks are the property of their respective owners.
© 2023 Diodes Incorporated. All Rights Reserved.

www.diodes.com

X-ON Electronics

Largest Supplier of Electrical and Electronic Components

Click to view similar products for [Power Management Specialised - PMIC category:](#)

Click to view products by [Diodes Incorporated manufacturer:](#)

Other Similar products are found below :

[FAN7710VN](#) [LA5657H-N-TLM-E](#) [LM10692RMYR](#) [SLG7NT4081VTR](#) [SLG7NT4192VTR](#) [AS3729B-BWLM](#) [MB39C831QN-G-EFE2](#)
[RT9026GQW](#) [LV56841PVD-XH](#) [L9781TR](#) [P91E0-I5NHGI](#) [S6AE102A0DGN1B200](#) [L9916](#) [AP4306BUKTR-G1](#) [SLG7NT4198V](#)
[NCP392CSFCCT1G](#) [LPTM21L-1ABG100I](#) [ISL99390FRZ-TR5935](#) [ISL69234IRAZ-T](#) [ISL69259IRAZ](#) [ISL69228IRAZ](#) [ISL69269IRAZ](#)
[AXP813](#) [FAN53870UC00X](#) [FDMF5085](#) [HPM10-W29A100G](#) [NCV97311MW50R2G](#) [WL2868C-20/TR](#) [TLE9263-3BQX](#) [TLE9263QX](#)
[TEA2095T/1J](#) [TEA2017AAT/2Y](#) [TPS650940A0RSKR](#) [TPS65177ARHAR](#) [LTC4417IUF#TRPBF](#) [AXP313A](#) [SQ24806AQSC](#) [RK805-2](#)
[RK809-2](#) [MFS2633AMBA0AD](#) [MFS2613AMDA3AD](#) [AD5522JSVUZ-RL](#) [LTC4352CMS#TRPBF](#) [LTC4359HDCB#TRPBF](#)
[LT4321IUF#TRPBF](#) [TC1017-2.5VLTTR](#) [MFS5600AMMA8ES](#) [TEA1716T/2](#) [MC33FS8510D3ESR2](#) [MMPF0100NPAZESR2](#)