

## Description

The AL5892 is an offline TRIAC dimmable linear LED driver with high integration of constant current control and smart bleeder operation. With the built-in 350V main power MOSFET and 500V bleeder MOSFET, the AL5892 offers users to design a TRIAC dimmable LED driver with extremely few external components and minimized system BOM cost. Because of the linear operation of the IC, the AL5892 LED driver is compliant with EMI standards without adding any EMI components. The AL5892 is optimized to work at 120VAC input mains voltage.

With an innovative efficiency compensation method, the AL5892 operates up to 85% efficiency with driving a single high-voltage LED chain.

The AL5892 detects TRIAC dimmer and controls the smart bleeder to turn on and off, thus it offers the LED driver good dimmer compatibility with both leading edge and trailing edge dimmers. The AL5892 also converts the dimmer signal to optimize the dimming curve to be compliant with NEMA SSL7.

The AL5892 has abundant of protection features, such as LED short protection (OSP), thermal foldback protection (TFP) and over temperature shutdown protection (OTP).

The AL5892 is available in SO-8EP (Type TH) package to enhance the thermal reliability of the LED driver.

## Features

- Integrated 350V Main MOSFET and 500V Bleeder MOSFET
- Low Operation Current: 300µA
- Tight Current Sense Tolerance: ±3%
- Output Current Programmable up to 75mA
- Wide Range of Dimmer Compatibility
- Dimming Curve Compliant to NEMA SSL7
- Internal Protections
  - LED Open/Short Protection (OSP)
  - Thermal Foldback Protection (TFP)
  - Over Temperature Shutdown Protection (OTP)
- Power Factor >0.7
- Efficiency up to 85%
- SO-8EP (Type TH) Package
- **Totally Lead-Free & Fully RoHS Compliant (Notes 1 & 2)**
- **Halogen and Antimony Free. "Green" Device (Note 3)**
- **For automotive applications requiring specific change control (i.e. parts qualified to AEC-Q100, PPAP capable, and manufactured in IATF 16949 certified facilities), please [contact us](mailto:contact@diodes.com) or your local Diodes representative. <https://www.diodes.com/quality/product-definitions/>**

- Notes:
1. No purposely added lead. Fully EU Directive 2002/95/EC (RoHS), 2011/65/EU (RoHS 2) & 2015/863/EU (RoHS 3) compliant.
  2. See <https://www.diodes.com/quality/lead-free/> for more information about Diodes Incorporated's definitions of Halogen- and Antimony-free, "Green" and Lead-free.
  3. Halogen- and Antimony-free "Green" products are defined as those which contain <900ppm bromine, <900ppm chlorine (<1500ppm total Br + Cl) and <1000ppm antimony compounds.

## Pin Assignments

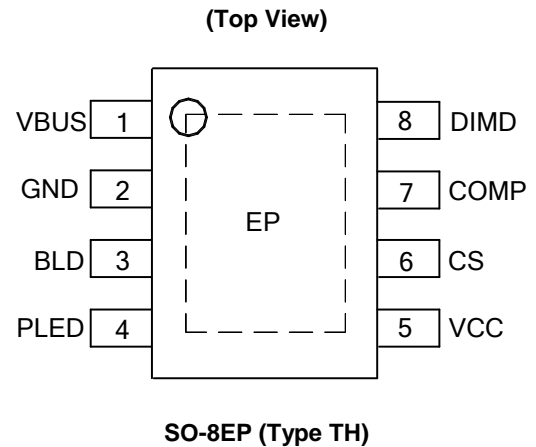

## Applications

- LED Lamps
- Retro Fit TRIAC Dimming
- LED Power Modules

**Pin Descriptions**

Pin Number	Pin Name	Function
1	VBUS	Rectified mains voltage sensing
2	GND	Ground of the IC
3	BLD	Drain of the internal Bleeder MOSFET
4	PLED	Connect with LED string negative terminal
5	VCC	Power supply for IC. Provides power for the internal control circuitry and gate driver
6	CS	Current sense pin. Connect a resistor from this pin to GND to set LED current
7	COMP	LED current Loop compensation capacitor input
8	DIMD	Dimmer detection signal Output. Connect with a capacitor to filter the output of the dimmer detection circuit
9	EP	Connect to GND

NEW PRODUCT

**Typical Applications Circuit**

Figure 1 shows the typical application of AL5892 along with basic external circuitry. Since this application example is designed to assess dimmer's relative on-time, the AL5892 can control the LED current accordingly. The AL5892 allows most phase-control dimmers, both forward and reverse phase, to be used.

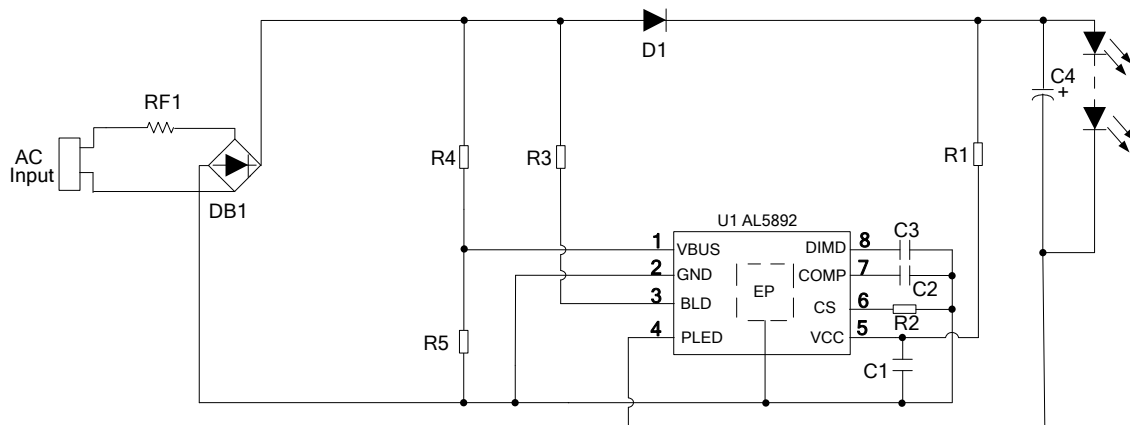

**Figure 1. AL5892 Typical Application**

**Functional Block Diagram**

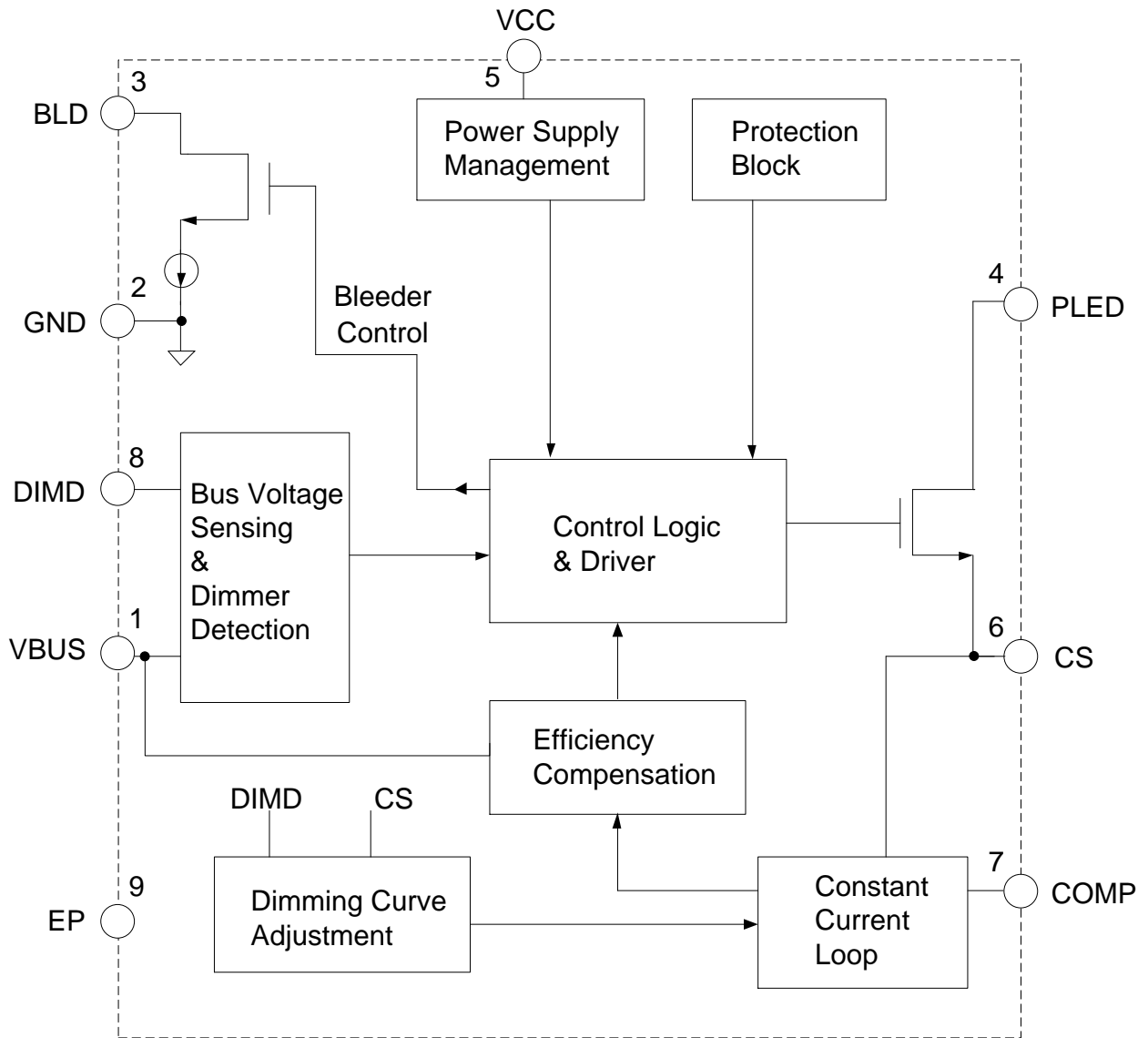

Figure 2. AL5892 Functional Block Diagram

NEW PRODUCT

### Absolute Maximum Ratings (@T<sub>A</sub> = +25°C, unless otherwise specified.)

Symbol	Parameter	Rating	Unit
V <sub>PLED</sub>	Voltage at PLED	350	V
V <sub>BLD</sub>	Voltage at BLD	500	V
I <sub>PLED</sub>	Current through PLED	400	mA
I <sub>BLD</sub>	Current through BLD	72	mA
V <sub>CS</sub> , V <sub>COMP</sub> , V <sub>DIMD</sub> , V <sub>BUS</sub>	Voltages at CS, COMP, DIMD, VBUS	-0.3 to +6	V
V <sub>CC</sub>	Input Supply Voltage	-0.3 to +24	V
T <sub>J</sub>	Operating Junction Temperature	-40 to +150	°C
T <sub>STG</sub>	Storage Temperature	-55 to +150	°C
ESD HBM	Human Body Model ESD Protection	2	kV
ESD CDM	Charge Device Model ESD Protection	1	kV

### Thermal Information

Package	Thermal Resistance Junction-to-Case θ <sub>JC</sub> (Note 4)	Thermal Resistance Junction-to-Ambient θ <sub>JA</sub> (Note 4)
SO-8EP (Type TH)	35.2°C/W (Note 6)	41.03°C/W (Note 5)
		63.78°C/W (Note 6)

Notes: 4. The test environment in θ<sub>JC</sub> and θ<sub>JA</sub> measurement following JEDEC standard.  
5. Tested when device mounted on a 2S2P PCB.  
6. Tested when device mounted on a 1S0P PCB.

### Recommended Operating Conditions (@T<sub>A</sub> = +25°C, unless otherwise specified.)

Symbol	Parameter	Min	Max	Unit
V <sub>AC</sub>	System AC Line RMS Input Voltage	108	132	VAC
V <sub>CC</sub>	V <sub>CC</sub> Operating Voltage	7.5	11	V
I <sub>PLED</sub>	LED RMS Current	—	75	mA
T <sub>A</sub>	Operating Ambient Temperature (Note 7)	-40	+105	°C

Note: 7. The device may operate normally at +125°C ambient temperature under the condition not trigger temperature protection.

**Electrical Characteristics** (Dimmer not present,  $V_{CC} = 10V$  @  $T_A = +25^\circ C$ , unless otherwise specified.)

Symbol	Parameter	Conditions	Min	Typ	Max	Unit
<b>VCC UVLO</b>						
$V_{CC\_UVLO\_R}$	VCC Startup Threshold	$V_{CC}$ Rising	—	11.6	—	V
$V_{CC\_UVLO\_F}$	VCC Minimum Operating Voltage	$V_{CC}$ Falling	—	7	—	V
$V_{CC\_CLAMP}$	VCC Clamp Voltage	—	—	12.5	—	V
<b>Current Consumption</b>						
$I_{CC}$	VCC Operation Supply Current	—	—	300	—	$\mu A$
<b>Constant Current Reference</b>						
$V_{REF}$	Internal Reference Voltage	Connect COMP and CS, measure $V_{COMP}$	0.288	0.3	0.312	V
$V_{CS\_HCLAMP}$	High Level Current Sense Clamp	$V_{COMP} = 4V$ , $V_{BUS} = 1V$	—	2	—	V
$V_{CS\_LCLAMP}$	Low Level Current Sense Clamp	$V_{COMP} = 0V$ , $V_{BUS} = 2.5V$	—	195	—	mV
<b>PLED Internal MOSFET</b>						
$I_{PLED\_OFF}$	PLED Pin OFF State Current	$V_{PLED} = 280V$	—	—	1.5	$\mu A$
$V_{BD\_PLED\_OFF}$	Breakdown Voltage on PLED (Note 8)	—	350	—	—	V
<b>Bleeder Operation</b>						
$V_{BD\_BLD}$	Breakdown Voltage on BLD (Note 8)	—	500	—	—	V
$I_{BLD\_OFF}$	BLD Pin OFF State Current	$V_{BLD} = 400V$ , $V_{CS} = 1V$ , $V_{DIMD} = 2.5V$ , bleeder OFF	—	—	75	$\mu A$
$I_{BLD\_ON}$	BLD Pin ON State Current	—	—	60	—	mA
$V_{CS\_BLD\_OFF}$	BLD Turn-Off Threshold Voltage	$V_{CS}$ voltage threshold to turn-off bleeder, $V_{DIM\_DET} = 1V$	—	165	—	mV
$V_{BUS}$	$V_{BUS}$ Voltage Range	—	0	—	2.5	V
$t_{BLD\_ON1}$	60mA Bleeding Holding Time	—	—	190	—	$\mu s$
$t_{CS\_LEB}$	CS LEB	—	—	5	—	$\mu s$
$V_{DIM\_DET}$	DIMD Voltage Threshold for Detection a Dimmer	—	—	2.4	—	V
<b>Error Amplifier</b>						
$I_{COMP\_O}$	Maximum COMP Source Current	$V_{CS} = 0V$ and $V_{COMP} = 2V$ , $V_{PLED} = OPEN$	—	4.5	—	$\mu A$
$I_{COMP\_I}$	Maximum COMP Sink Current	$V_{CS} = 2V$ and $V_{COMP} = 2V$ , $V_{PLED} = OPEN$	—	28	—	$\mu A$
$G_m$	Error Amplifier Transconductance $\Delta I_{COMP} / \Delta V_{CS}$	Sweep $V_{CS}$ from 0.2V to 0.4V and measure $I_{COMP}$ at $V_{COMP} = 0.3V$ , $V_{PLED} = 30V$ . Calculate $G_m$	—	16.5	—	$\mu A/V$
<b>Protection Threshold</b>						
TREG	Thermal Regulated Trigger Temperature	Temperature to fold back LED current by 50%	—	+150	—	$^\circ C$
SHDN	Thermal Shutdown	Temperature to shutdown LED current	—	+165	—	$^\circ C$

 Note 8: The drain-source voltage is 80% of  $V_{DS}$  in the aging condition.

Typical Performance Characteristics

NEW PRODUCT

V<sub>CC</sub> Startup Threshold vs. Temperature

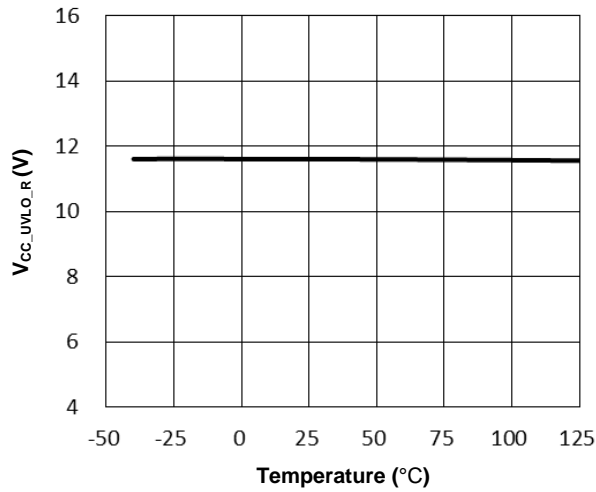

V<sub>CC</sub> Minimum Operating Voltage vs. Temperature

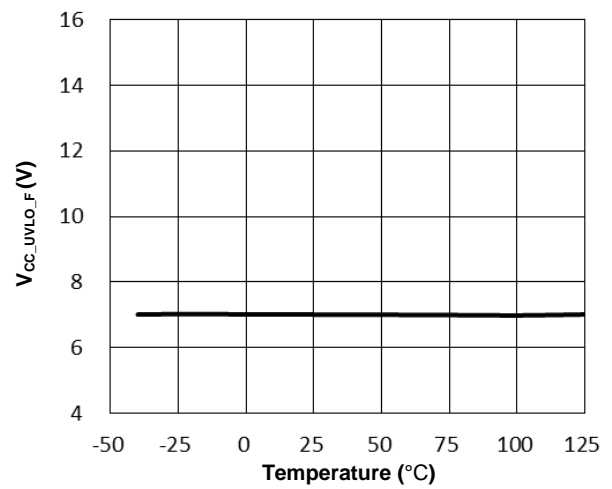

V<sub>CC</sub> Operation Supply Current vs. Temperature

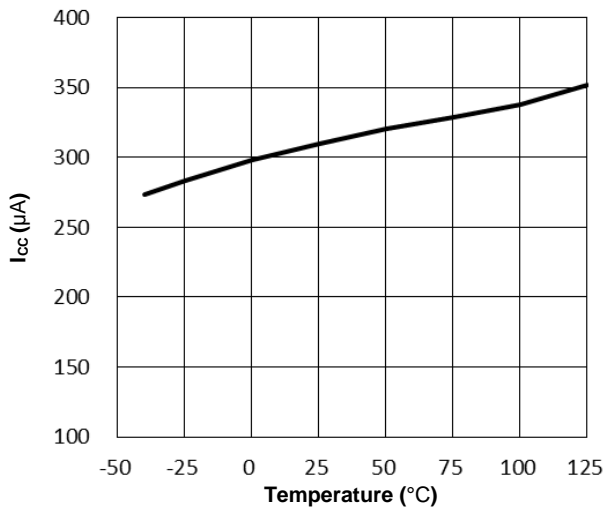

Internal Reference Voltage vs. Temperature

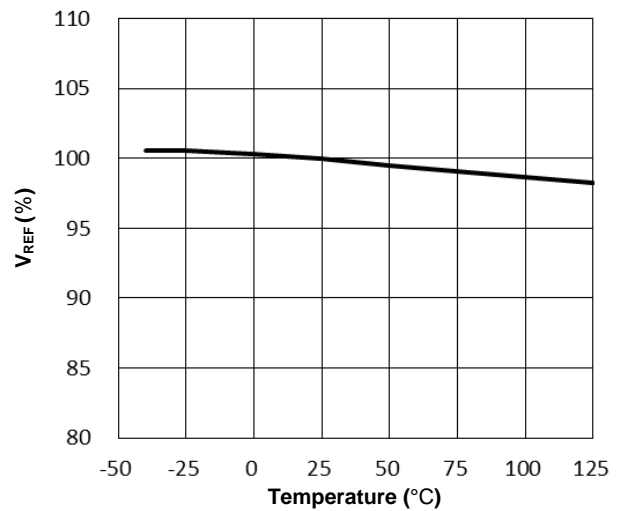

30mA Bleeding Current vs. Temperature

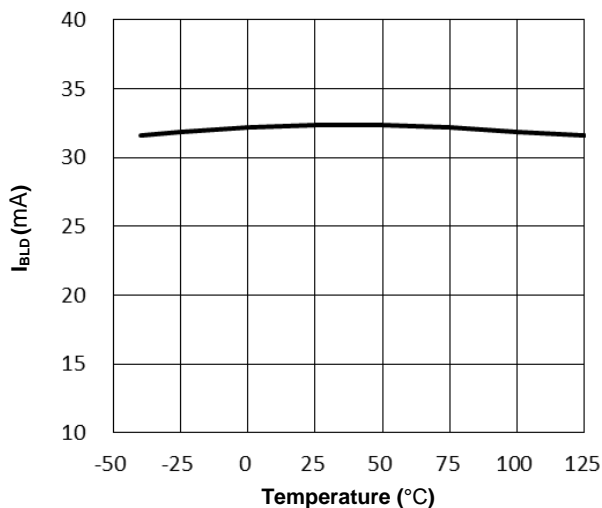

LED Current vs. Temperature

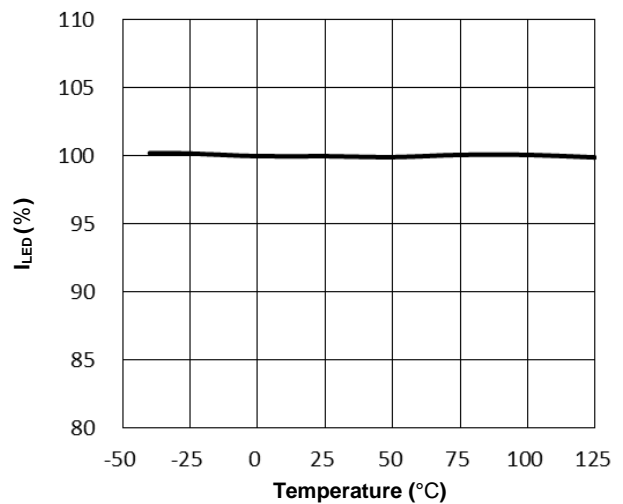

**Functional Description and Application Information**

**Power Supply**

The AL5892's internal power is derived through an external R-C network between VLED+ and the VCC pin. An internal diode-capacitor network is used to maintain the voltage on the VCC pin while the voltage on the VLED+ goes low. An internal JEFT also provides a redundant supply to operate the AL5892.

**Setting the LED Current**

Figure 1 shows the typical output drive configuration. The feedback loop regulates the current through the LEDs. The voltage across the external resistor (R2) is fed to the CS pin for sensing. The output LED current can be set as following:

$$I_{LED} = \frac{V_{CS}}{R2} \quad (1)$$

Where  $I_{LED}$  is the desired LED current,  $V_{CS}$  is determined by the internal 0.3V reference voltage  $V_{REF}$ .

**Bleeder Consideration**

To emulate an incandescent light bulb with an LED driver, the existing TRIAC dimmers on markets require a small amount of holding, or bleeding, current throughout the AC line cycle. This means an LED driver must provide an additional load so that the dimmer delay circuit can operate correctly. Most TRIACs only require a few milliamps of current to hold them on. Some low-cost TRIACs may require a little higher holding current. Generally speaking, higher holding current will make TRIACs operation more reliable. The trade-off is performance vs efficiency. Reducing the holding current will improve the overall efficiency. The AL5892 uses the BLD (bleeder) pin to perform this function.

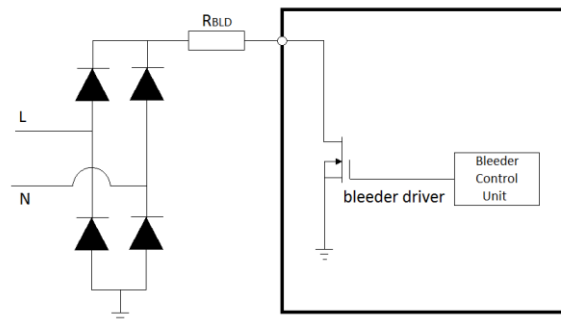
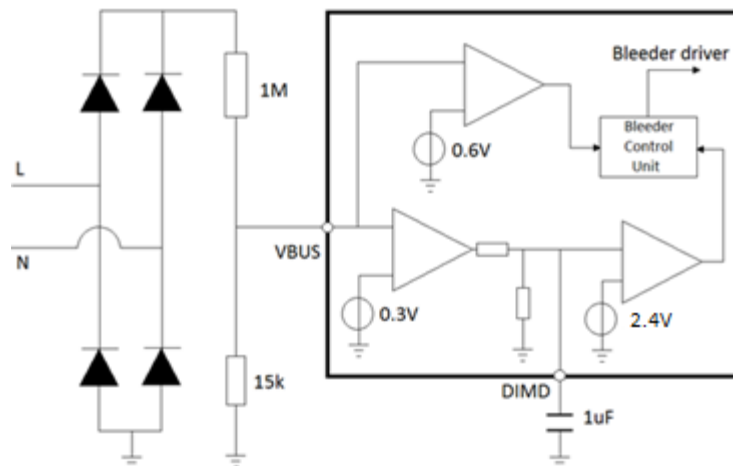

**Figure 3. Internal Bleeder Circuitry**

If a TRIAC dimmer is presented, the bleeder MOSFET is active to place a load on the AC line. When the dimmer edge comes or the line voltage is below 40V, the bleeder MOSFET will be turned on to hold the TRIAC dimmer. When the current through main MOSFET is above 28mA, the bleeder MOSFET will be turned off to save power loss.

**Phase Angle and Dimmer Detection**

The AL5892 measures the rectified AC line voltage via the pin VBUS as shown in Figure 4, that is used to derive the TRIAC angle information. According the voltage on pin DIMD, the AL5892 determines if the dimmer does exist or not.

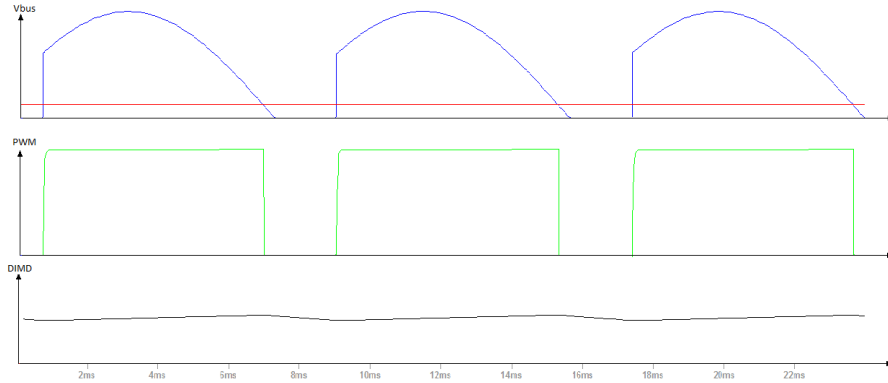

**Figure 4. Phase angle and dimmer Detection**

NEW PRODUCT

**Functional Description and Application Information** (continued)

By using resistors divider, a proportion of rectified mains voltage can be got as input to a phase-detection comparator. The comparator has a nominal threshold of 0.3V. The comparator generates a 0V to 5V PWM signal with a duty cycle proportional to TRIAC dimmer conduction angle. PWM signal is presented to a R-C low-pass filter with a bandwidth on the order of 1Hz. This RC filter finally produces a DC level signal (DIMD) which corresponds to the TRIAC's conduction angle.



**Figure 5. AL5892 Dimmer Detection PWM Waveform**

As input signal of dimmer-detection comparator, DIMD signal is compared with a threshold of 2.4V. When no dimmer is present, DIMD will be higher than 2.4V; the AL5892 makes the bleeder inactive to improve efficiency. When a dimmer exists, DIMD will be lower than 2.4V; the bleeder circuit will be active.

According to the detection method, those TRIAC dimmers with lower than 161° conduction angle can be identified by AL5892.

Based on this measured conduction angle information the dimming curve can be produced. It is clear that the RC filter will produce the maximum DC level, when no dimmer is present, and in response the AL5892 makes the bleeder inactive to improve efficiency.

**LED Open and Short Detection**

The AL5892 can survive LED open/short fault with rated line voltage range input. Within an AC cycle, in short condition, the time of current through main MOSFET will be much longer than in normal condition. The AL5892 detects the width of CS, when the CS current width is longer than a threshold, it means LED short happening.

In LED short condition, the AL5892 pulls down the COMP pin voltage to minimize the input power, and the main MOSFET will turn on one time in five half AC sine cycle to prevent IC overheat. That also makes it auto-recovery when LED short condition is removed.

When LED is open, the voltage of E-CAP between LED+ and LED- will rise up to the peak value of line voltage, the current through the main MOSFET will decrease to 0 naturally.

**Thermal Fold Back and Shutdown (OTP)**

Thermal Fold Back happens when the IC junction temperature reaches about +150°C, which limits AL5892's power dissipation by reducing more than 50% LED current.

Thermal Shutdown turns off the output MOSFET when the IC junction temperature exceeds +165°C typical.

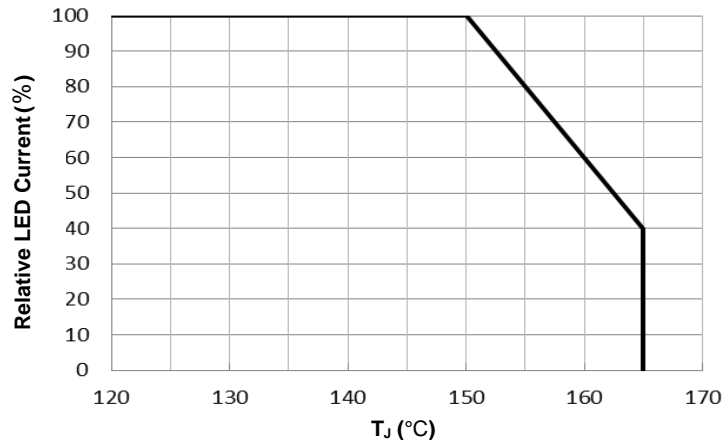

**Figure 6. Thermal Fold Back**



**Functional Description and Application Information** (continued)

**Dimming Curves**

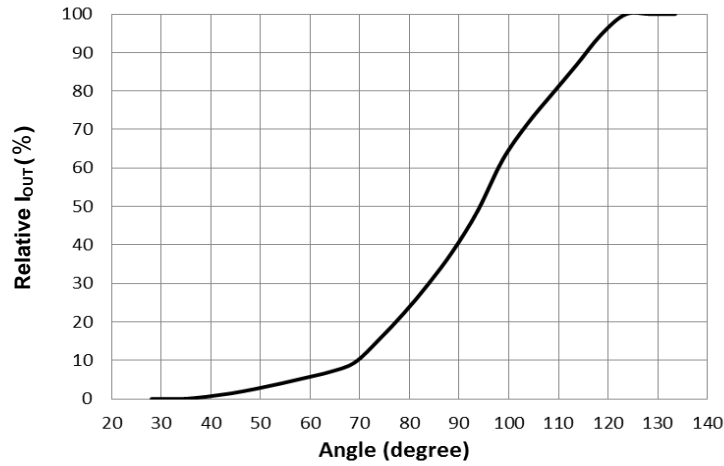
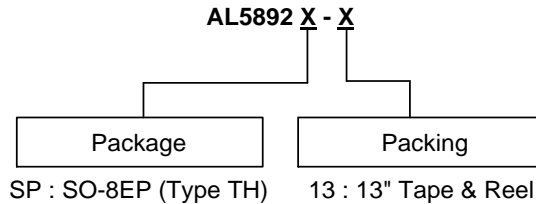

Figure 7. Relative LED Current vs. TRIAC Phase Angle

**Multiple AL5892 in Parallel**

The LED current can be increased by connecting two or more AL5892 in parallel.

**Ordering Information**



Part Number	Package Code	Package (Note 9)	13" Tape and Reel	
			Quantity	Part Number Suffix
AL5892SP-13	SP	SO-8EP (Type TH)	4000/Tape & Reel	-13

Note: 9. For packaging details, go to our website at <https://www.diodes.com/design/support/packaging/diodes-packaging/>.

**Marking Information**

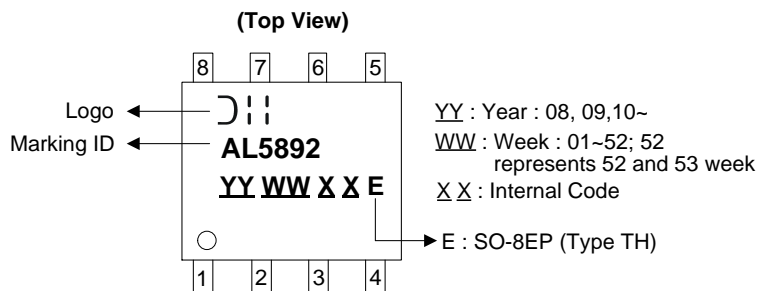

**Package Outline Dimensions**

Please see <http://www.diodes.com/package-outlines.html> for the latest version.

SO-8EP (Type TH)

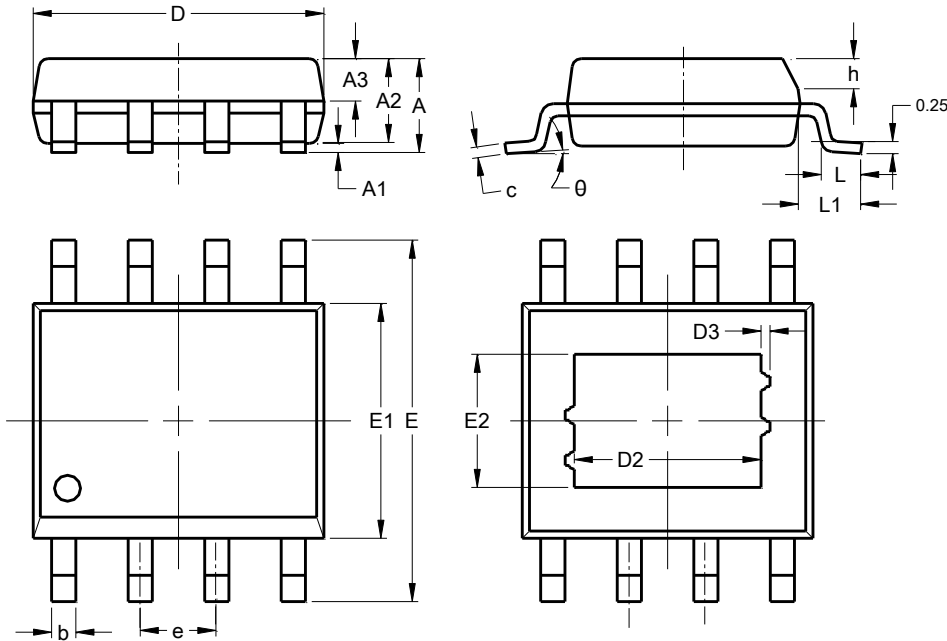

SO-8EP (Type TH)			
Dim	Min	Max	Typ
A	--	1.65	--
A1	0.05	0.15	--
A2	1.30	1.50	1.40
A3	0.60	0.70	0.65
b	0.39	0.48	--
c	0.21	0.25	--
D	4.70	5.10	4.90
D2	3.10REF		
D3	0.10REF		
E	5.80	6.20	6.00
E1	3.70	4.10	3.90
E2	2.21REF		
e	1.27BSC		
h	0.25	0.50	--
L	0.50	0.80	0.60
L1	1.05REF		
θ	0°	8°	--
All Dimensions in mm			

**Suggested Pad Layout**

Please see <http://www.diodes.com/package-outlines.html> for the latest version.

SO-8EP (Type TH)

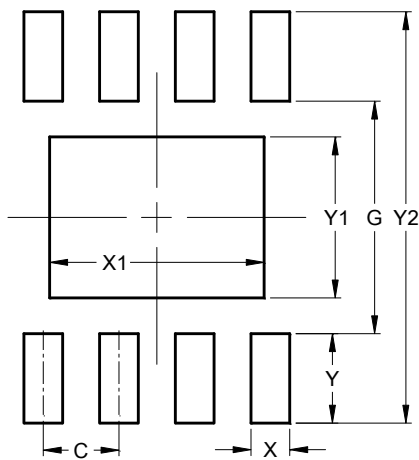

Dimensions	Value (in mm)
C	1.270
G	3.900
X	0.650
X1	3.600
Y	1.500
Y1	2.700
Y2	6.900

**IMPORTANT NOTICE**

DIODES INCORPORATED MAKES NO WARRANTY OF ANY KIND, EXPRESS OR IMPLIED, WITH REGARDS TO THIS DOCUMENT, INCLUDING, BUT NOT LIMITED TO, THE IMPLIED WARRANTIES OF MERCHANTABILITY AND FITNESS FOR A PARTICULAR PURPOSE (AND THEIR EQUIVALENTS UNDER THE LAWS OF ANY JURISDICTION).

Diodes Incorporated and its subsidiaries reserve the right to make modifications, enhancements, improvements, corrections or other changes without further notice to this document and any product described herein. Diodes Incorporated does not assume any liability arising out of the application or use of this document or any product described herein; neither does Diodes Incorporated convey any license under its patent or trademark rights, nor the rights of others. Any Customer or user of this document or products described herein in such applications shall assume all risks of such use and will agree to hold Diodes Incorporated and all the companies whose products are represented on Diodes Incorporated website, harmless against all damages.

Diodes Incorporated does not warrant or accept any liability whatsoever in respect of any products purchased through unauthorized sales channel. Should Customers purchase or use Diodes Incorporated products for any unintended or unauthorized application, Customers shall indemnify and hold Diodes Incorporated and its representatives harmless against all claims, damages, expenses, and attorney fees arising out of, directly or indirectly, any claim of personal injury or death associated with such unintended or unauthorized application.

Products described herein may be covered by one or more United States, international or foreign patents pending. Product names and markings noted herein may also be covered by one or more United States, international or foreign trademarks.

This document is written in English but may be translated into multiple languages for reference. Only the English version of this document is the final and determinative format released by Diodes Incorporated.

**LIFE SUPPORT**

Diodes Incorporated products are specifically not authorized for use as critical components in life support devices or systems without the express written approval of the Chief Executive Officer of Diodes Incorporated. As used herein:

A. Life support devices or systems are devices or systems which:

1. are intended to implant into the body, or
2. support or sustain life and whose failure to perform when properly used in accordance with instructions for use provided in the labeling can be reasonably expected to result in significant injury to the user.

B. A critical component is any component in a life support device or system whose failure to perform can be reasonably expected to cause the failure of the life support device or to affect its safety or effectiveness.

Customers represent that they have all necessary expertise in the safety and regulatory ramifications of their life support devices or systems, and acknowledge and agree that they are solely responsible for all legal, regulatory and safety-related requirements concerning their products and any use of Diodes Incorporated products in such safety-critical, life support devices or systems, notwithstanding any devices- or systems-related information or support that may be provided by Diodes Incorporated. Further, Customers must fully indemnify Diodes Incorporated and its representatives against any damages arising out of the use of Diodes Incorporated products in such safety-critical, life support devices or systems.

Copyright © 2019, Diodes Incorporated

[www.diodes.com](http://www.diodes.com)

## X-ON Electronics

Largest Supplier of Electrical and Electronic Components

*Click to view similar products for [LED Lighting Drivers](#) category:*

*Click to view products by [Diodes Incorporated](#) manufacturer:*

Other Similar products are found below :

[LV5235V-MPB-H](#) [MB39C602PNF-G-JNEFE1](#) [MIC2871YMK-T5](#) [AL1676-10BS7-13](#) [AL1676-20AS7-13](#) [AP5726WUG-7](#) [MX877RTR](#)  
[ICL8201](#) [IS31BL3228B-UTLS2-TR](#) [IS31BL3506B-TTLS2-TR](#) [AL3157F-7](#) [AP5725FDCG-7](#) [AP5726FDCG-7](#) [LV52204MTTBG](#)  
[SLG7NT4082VTR](#) [AP5725WUG-7](#) [STP4CMPQTR](#) [NCL30086BDR2G](#) [CAT4004BHU2-GT3](#) [LV52207AXA-VH](#) [AP1694AS-13](#)  
[TLE4242EJ](#) [AS3688](#) [IS31LT3172-GRLS4-TR](#) [TLD2311EL](#) [KTD2694EDQ-TR](#) [KTZ8864EJAA-TR](#) [IS32LT3174-GRLA3-TR](#)  
[ZXLD1374QESTTC](#) [AL1676-20BS7-13](#) [IS31FL3737B-QFLS4-TR](#) [IS31FL3239-QFLS4-TR](#) [KTD2058EUAC-TR](#) [KTD2037EWE-TR](#)  
[DIO5662ST6](#) [IS31BL3508A-TTLS2-TR](#) [MAX20052CATC/V+](#) [MAX25606AUP/V+](#) [BD6586MUV-E2](#) [BD9206EFV-E2](#) [BD9416FS-E2](#)  
[LYT4227E](#) [LYT6079C-TL](#) [MP3394SGF-P](#) [MP4689AGN-P](#) [MPQ4425AGQB-AEC1-Z](#) [TLD1311ELXUMA1](#) [TLE4309GATMA1](#)  
[MIC2873YCS-TR](#) [TPS92410DR](#)