

Description

The AL8871Q is an LED driver, controller IC for driving external MOSFETs to drive high-current LEDs. The buck-boost topology controller enables it to efficiently control the current through series-connected LEDs. The 60V capability enables it to be used in a wide range of applications and drive in excess of 15 LEDs in series.

The AL8871Q is a modified hysteretic controller using a patent-pending control scheme providing high-output current accuracy. High-accuracy dimming is achieved through DC control and high-frequency PWM control.

The AL8871Q uses two pins for fault diagnosis. A flag output highlights a fault, while the multi-level status pin gives further information on the exact fault.

The AL8871Q has been qualified to AEC-Q100 Grade 1 and is automotive compliant supporting PPAPs.

Pin Assignments

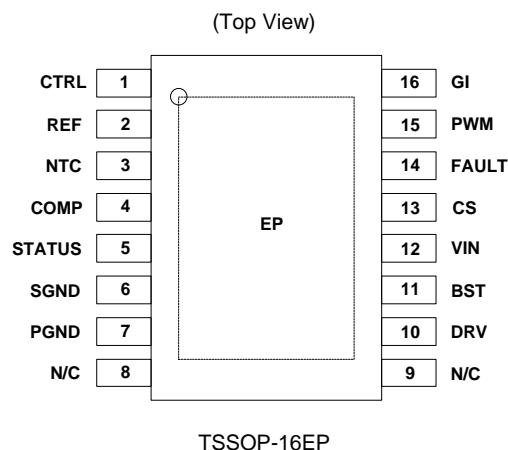

Features

- AEC-Q100 Grade 1 Qualified
- Wide Input Voltage Range: 5V to 60V
- Operating Frequency Up to 1MHz
- Analog Dimming Range: 10% to 100%
- 1000:1 PWM Dimming Resolution at 500 Hz
- High Temperature Control of LED Current Using T_{CTRL}
- Fault Reporting for Abnormal Operations
- Overtemperature Shutdown
- Available in Thermally Enhanced TSSOP-16EP Package
- **Totally Lead-Free & Fully RoHS Compliant (Notes 1 & 2)**
- **Halogen- and Antimony-Free. "Green" Device (Note 3)**
- **For automotive applications requiring specific change control (i.e. parts qualified to AEC-Q100/101/200, PPAP capable, and manufactured in IATF 16949 certified facilities), please [contact us](https://www.diodes.com/quality/product-definitions) or your local Diodes representative. <https://www.diodes.com/quality/product-definitions>**

Applications

- Automotive Daytime Running Lights
- Automotive Head Lamps
- Automotive Fog Lamps
- Automotive Interior Lamps

- Notes:
1. No purposely added lead. Fully EU Directive 2002/95/EC (RoHS), 2011/65/EU (RoHS 2) & 2015/863/EU (RoHS 3) compliant.
 2. See <https://www.diodes.com/quality/lead-free/> for more information about Diodes Incorporated's definitions of Halogen- and Antimony-free, "Green" and Lead-free.
 3. Halogen- and Antimony-free "Green" products are defined as those which contain <900ppm bromine, <900ppm chlorine (<1500ppm total Br + Cl) and <1000ppm antimony compounds.

Typical Applications Circuit

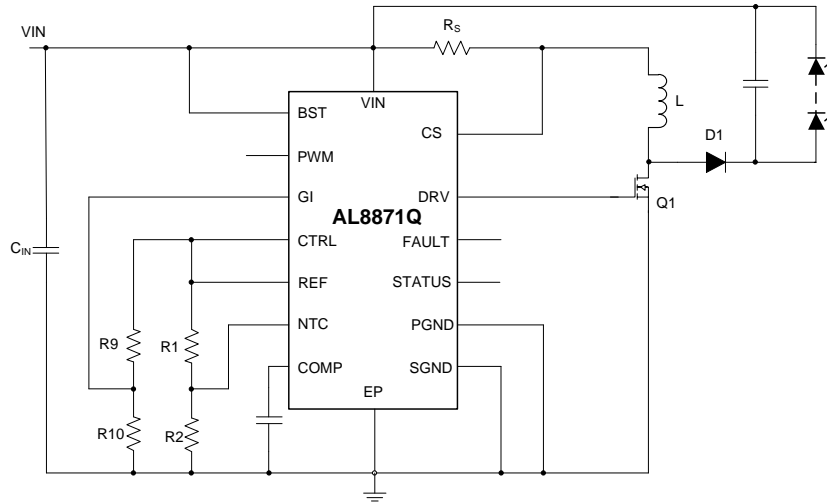

Figure 1. Typical Application Circuit

Pin Descriptions

Pin Name	Pin	Type (Note 4)	Description
CTRL	1	I	Adjust Input (for DC Output Current Control). Connect to REF to set 100% output current. Drive with DC voltage ($125\text{mV} < V_{\text{CTRL}} < 1.25\text{V}$) to adjust output current from 10% to 100% of preset value. The CTRL pin has an internal clamp that limits the internal node to less than 3V, which provides some failsafe should they get overdriven.
REF	2	O	Internal 1.25V Reference Voltage Output.
NTC	3	I	Temperature Adjust Input for LED Thermal Current Control. Connect thermistor/resistor network to this pin to reduce output current above a preset temperature threshold. Connect to REF to disable thermal compensation function.
COMP	4	I/O	Shaping Capacitor for Feedback Control Loop. Connect 330pF $\pm 20\%$ capacitor from this pin to ground to provide loop compensation.
STATUS	5	O	Operation Status Output (Analog Output). Pin is at 4.5V (nominal) during normal operation. Pin switches to a lower voltage to indicate specific operation warnings or fault conditions. Status pin voltage is low during shutdown mode.
SGND	6	P	Signal Ground (Connect to 0V).
PGND	7	P	Power Ground. Connect to 0V and pin 8 to maximize copper area.
N/C	8	—	Not Connected Internally. Recommend connection to pin 7, (PGND), to maximize PCB copper for thermal dissipation.
N/C	9	—	Not Connected Internally. Recommend connection pin 10 (DRV) to permit wide copper trace to gate of MOSFET.
DRV	10	O	Gate Drive Output to External NMOS Transistor. Connect to Pin 9.
BST	11	P	Auxiliary Positive Supply to Internal Switch Gate Driver. At $V_{\text{IN}} < 8\text{V}$; a bootstrap circuit (where applicable) is recommended to ensure adequate gate drive voltage (see <i>Applications</i> section). At $V_{\text{IN}} > 8\text{V}$; connect to V_{IN} . At $V_{\text{IN}} > 24\text{V}$; to reduce power dissipation, BST can be connected to an 8V to 15V auxiliary power supply (see <i>Applications</i> section). Decouple to ground with capacitor close to device (see <i>Applications</i> section).
VIN	12	P	Input Supply to Device 5V to 60V. Decouple to ground with capacitor close to device (refer to <i>Applications</i> section).
CS	13	I	Current Monitor Input. Connect current sense resistor between this pin and VIN. The nominal voltage, V_{SENSE} , across the resistor initially 225mV varying with duty cycle.
FAULT	14	O	Flag Open Drain Output. Pin is high impedance during normal operation. Pin switches low to indicate a fault, or warning condition.
PWM	15	I	Digital PWM Output Current Control. Pin driven either by open-drain or push-pull 3.3V or 5V logic levels. Internal pull up to 4.45V when floating Drive with frequency higher than 100Hz to gate output <i>on</i> and <i>off</i> during dimming control. The device enters standby mode when PWM pin is driven with logic-low level for more than 15ms nominal (refer to <i>Applications</i> section for more details).
GI	16	I	Gain Setting Input. Used to set the device to control the sense voltage. Connect to resistive divider from CTRL to SGND. The GI divider is required to compensate for duty cycle gating in the internal feedback loop (see <i>Applications</i> section). The GI pin has an internal clamp that limits the internal node to less than 3V. This provides some failsafe should it become overdriven.
EP	PAD	P	Exposed Paddle. Connect to GND plane for electrical and thermal management.

Note: 4. Type refers to whether or not pin is an input, output, input/output, or power supply pin.

Functional Block Diagram

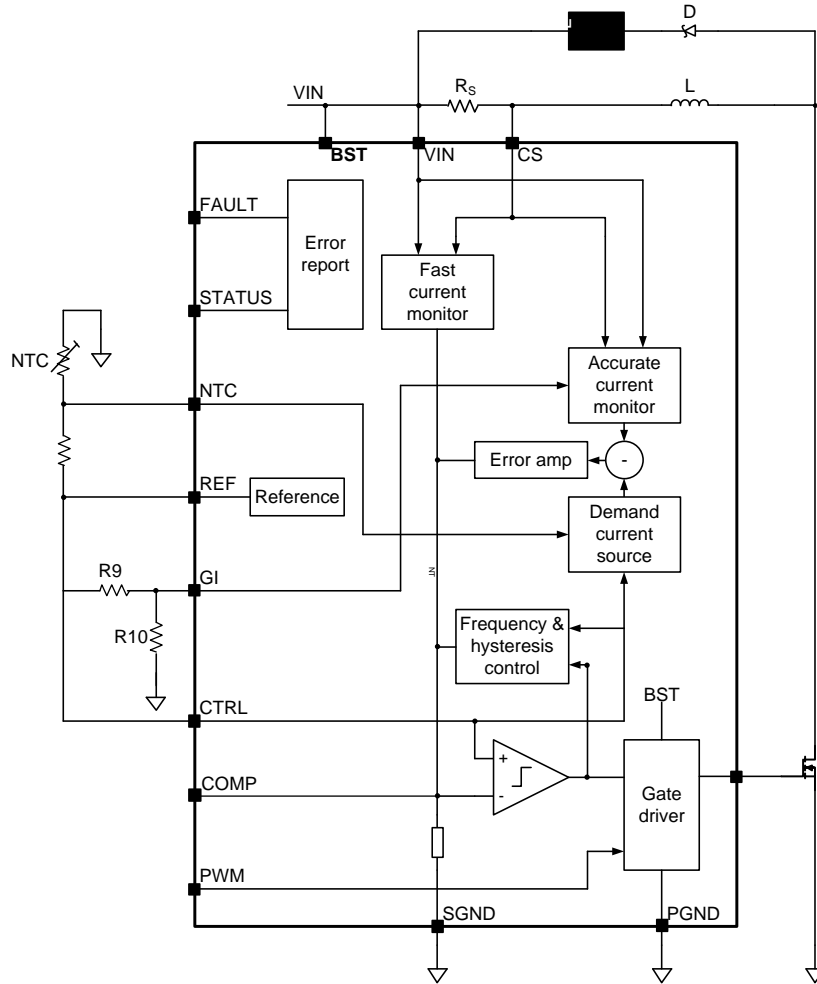

Figure 2. Functional Block Diagram

Absolute Maximum Ratings (Note 5)

Symbol	Parameter	Rating	Unit
VIN	Input Supply Voltage	-0.3 to 65	V
BST	Auxiliary Supply Voltage	-0.3 to 65	V
VCS	Current Monitor Input Relative to GND	-0.3 to 65	V
VSENSE	Current Monitor Sense Voltage (VIN-VCS)	-0.3 to 5	V
VDRV	Gate Driver Output Voltage	-0.3 to 20	V
IDRV	Gate Driver Continuous Output Current	18	mA
VFAULT	Flag Output Voltage	-0.3 to 40	V
VPWM, VCTRL, VNTC, VGI, VPWM	Other Input Pins	-0.3 to 5.5	V
T _J	Maximum Junction Temperature	+150	°C
T _{ST}	Storage Temperature	-55 to +150	°C

Note: 5. Stresses greater than those listed under *Absolute Maximum Ratings* can cause permanent damage to the device. These are stress ratings only, and functional operation of the device at these or any other conditions beyond those indicated under *Recommended Operating Conditions* is not implied. Exposure to *Absolute Maximum Ratings* for extended periods can affect device reliability.

ESD Ratings

Symbol	Parameter	Rating	Unit
V _{ESD}	Human Body Model (HBM)	±1500	V
	Charged Device Model (CDM)	±1000	

Thermal Information (Note 6)

Symbol	Parameter	Rating	Unit
θ _{JA}	Junction-to-ambient thermal resistance	50	°C/W
θ _{JC}	Junction-to-case(top) thermal resistance	23	°C/W

Notes: 6. Measured on *High Effective Thermal Conductivity Test Board* according to JESD51.

Recommended Operating Conditions

Symbol	Parameter	Performance/Comment	Min	Max	Unit
V _{IN}	Input Supply Voltage Range	Normal Operation	8.0	60	V
		Reduced Performance Operation (Note 7)	5.0	8.0	
V _{BST}	Auxiliary Supply Voltage Range (Note 8)	Normal Operation	8.0	60	V
		Reduced Performance Operation (Note 7)	5.0	8.0	
V _{SENSE}	Differential Input Voltage	V _{IN} -V _{CS} , with 0 ≤ V _{CTRL} ≤ 2.5	0	450	mV
V _{CTRL}	External DC Control Voltage Applied to CTRL pin to Adjust Output Current	DC Brightness Control Mode From 10% to 100%	0.125	1.25	V
I _{REF}	Reference External Load Current	REF Sourcing Current	—	1	mA
f _{max}	Recommended Switching Frequency Range	(Note 9)	300	1000	kHz
V _{NTC}	Temperature Adjustment (NTC) Input Voltage Range	—	0	V _{REF}	V
f _{PWM}	Recommended PWM Dimming Frequency Range	To Achieve 1000:1 Resolution	100	500	Hz
		To Achieve 500:1 Resolution	100	1000	Hz
t _{PWMH/L}	PWM Pulse Width In Dimming Mode	PWM Input High or Low	0.002	10	ms
V _{PWMH}	PWM Pin High Level Input Voltage	—	2	5.5	V
V _{PWML}	PWM Pin Low Level Input Voltage	—	0	0.4	V
T _J	Operating Junction Temperature Range	—	-40	+125	°C
GI	Gain Setting Ratio	Ratio= V _G /V _{CTRL}	0.20	0.50	—

Notes:

- Device starts up above 5.4V, and as such, the minimum applied supply voltage must be above 5.4V (plus any noise margin). However, the AL8871Q continues to function when the input voltage is reduced from ≥ 8V down to 5.0V. When operating with input voltages below 8V, the output current and device parameters may deviate from their normal values and are dependent on power MOSFET switch, load, and ambient temperature conditions. To ensure best operation with input voltages, V_{IN}, between 5V and 8V a suitable bootstrap network on BST pin is recommended.
- BST can be driven from a voltage higher than V_{IN} to provide higher efficiency at low V_{IN} voltages, but to avoid false operation; a voltage must not be applied to BST in the absence of a voltage at V_{IN}. BST can also be operated at a lower voltage than V_{IN} to increase efficiencies at high V_{IN}.
- The device contains circuitry to control the switching frequency to approximately 400kHz.

Electrical Characteristics (Test conditions: $V_{IN} = V_{BST} = 12V$, $T_A = 25^\circ C$, unless otherwise specified.)

Symbol	Parameter	Conditions	Min	Typ	Max	Units
Supply and Reference Parameters						
V_{UV-}	Undervoltage Detection Threshold Normal Operation to Switch Disabled	V_{IN} or V_{BST} Falling (Note 10)	—	4.5	—	V
V_{UV+}	Undervoltage Detection Threshold Switch Disabled to Normal Operation	V_{IN} or V_{BST} Rising (Note 10)	—	4.9	—	V
I_{Q-IN}	Quiescent Current into V_{IN}	PWM Pin Floating Output Not Switching	—	1.5	3	mA
I_{Q-AUX}	Quiescent Current into BST		—	150	300	μA
I_{SB-IN}	Standby Current into V_{IN}	PWM Pin Grounded for More Than 15ms	—	90	150	μA
I_{SB-AUX}	Standby Current into BST		—	0.7	10	μA
V_{REF}	Internal Reference Voltage	No Load	1.237	1.25	1.263	V
ΔV_{REF}	Change in Reference Voltage with Output Current	Sourcing 1mA	-5	—	—	mV
		Sinking 25 μA	—	—	5	
V_{REF_LINE}	Reference Voltage Line Regulation	$V_{IN} = V_{BST}$, $8.0V < V_{IN} = < 60V$	-60	-90	—	dB
V_{REF_TC}	Reference Temperature Coefficient	—	—	± 50	—	ppm/ $^\circ C$
DC-DC Converter Parameters						
I_{CTRL}	CTRL Input Current (Note 11)	$V_{CTRL} \leq 1.25V$	—	—	100	nA
		$V_{CTRL} = 5.0V$	—	—	5	μA
V_{GI}	GI Voltage threshold (Note 11)	$V_{CTRL} = 1.25V$	—	—	0.8	V
I_{GI}	GI Input Current (Note 11)	$V_{GI} \leq 1.25V$	—	—	100	nA
		$V_{GI} = 5.0V$	—	—	5	μA
I_{PWM}	PWM Input Current	$V_{PWM} = 5.5V$	—	36	100	μA
t_{PWMoff}	PWM Pulse Width (to Enter Shutdown State)	PWM Input Low	10	15	25	ms
T_{SDH}	Thermal Shutdown Upper Threshold (DRV Output Forced Low)	Temperature Rising	—	150	—	$^\circ C$
T_{SDL}	Thermal Shutdown Lower Threshold (DRV Output Re-Enabled)	Temperature Falling	—	125	—	$^\circ C$
High-Side Current Monitor (Pin CS)						
I_{CS}	Input Current	Measured into CS pin $V_{CS} = 12V$	—	11	20	μA
V_{SENSE_acc}	Accuracy of Nominal V_{SENSE} Threshold Voltage	$V_{CTRL} = 1.25V$	—	± 0.25	± 2	%
$V_{SENSE-OC}$	Over-Current Sense Threshold Voltage		300	350	375	mV

Notes: 10. UVLO levels are such that all AL8871Q will function above 5.4V for rising supply voltages and function down to 5V for falling supply voltages.
11. The CTRL and GI pins have an internal clamp that limits the internal node to less than 3V. This provides some failsafe should those pins get overdriven.

Electrical Characteristics (continued) (Test conditions: $V_{IN} = V_{BST} = 12V$, $T_A = +25^\circ C$, unless otherwise specified.)

Symbol	Parameter	Conditions	Min	Typ	Max	Units		
Output Parameters								
V_{FAULTL}	FAULT Pin Low Level Output Voltage	Output Sinking 1mA	—	—	0.5	V		
$I_{FAULTOFF}$	FAULT Pin Open-Drain Leakage Current	$V_{FAULT} = 40V$	—	—	1	μA		
V_{STATUS}	STATUS Flag No-Load Output Voltage (Note 12)	Normal Operation	4.2	4.5	4.8	V		
		Out of Regulation (V_{COMP} out of range) (Note 13)	3.3	3.6	3.9			
		V_{IN} Undervoltage ($V_{IN} < UVLO$)	3.3	3.6	3.9			
		Switch Stalled (t_{ON} or $t_{OFF} > 100\mu s$)	3.3	3.6	3.9			
		Overtemperature ($T_J > +125^\circ C$)	1.5	1.8	2.1			
	Excess Sense Resistor Current ($V_{SENSE} > 0.32V$)	0.6	0.9	1.2				
R_{STATUS}	Output Impedance of STATUS Output	Normal Operation	—	10	—	$k\Omega$		
Driver Output (PIN DRV)								
V_{DRVH}	High Level Output Voltage	No load Sourcing 1mA (Note 14)	$V_{IN} = V_{BST} = 12V$		10	11	12	V
V_{DRVL}	Low Level Output Voltage	Sinking 1mA, (Note 15)	—	—	0.5		V	
V_{DRVCL}	High Level DRV CLAMP Voltage	$V_{IN} = V_{AU X} = V_{CS} = 18V$ $I_{DRV} = 1mA$	—	12.8	15		V	
I_{DRV}	Dynamic Peak Current Available During Rise or Fall of Output Voltage	Charging or Discharging gate of External Switch with $Q_G = 10nC$ and 400kHz	—	± 300	—		mA	
t_{STALL}	Time to Assert STALL Flag and Warning on STATUS Output (Note 16)	DRV Low or High	—	100	170		μs	
LED Thermal Control Circuit (NTC) Parameters								
V_{NTCH}	Upper Threshold Voltage	Onset of Output Current Reduction (V_{NTC} Falling)	560	625	690		mV	
V_{NTCL}	Lower Threshold Voltage	Output Current Reduced to <10% of Set Value (V_{NTC} Falling)	380	440	500		mV	
I_{NTC}	NTC Pin Input Current	$V_{NTC} = 1.25V$	—	—	1		μA	

- Notes:
- In the event that more than one fault/warning condition occurs, the higher priority condition takes precedence. For example *Excessive coil current* and *Out of regulation* occurring together produces an output of 0.9V on the STATUS pin. These STATUS pin voltages apply for an input voltage to V_{IN} of $7.5V < V_{IN} < 60V$. Below 7.5V the STATUS pin voltage levels reduce and therefore may not report the correct status. For $5.4V < V_{IN} < 7.5V$, the FAULT pin still reports any error by going low. At low V_{IN} , an overcurrent status may be indicated when operating at high boost ratios—this is due to the feedback loop increasing the sense voltage. For more information see the *Application Information* section about FAULT/Status levels.
 - FAULT is asserted if $V_{COMP} < 1.5V$ or $V_{COMP} > 2.5V$.
 - DRV is switched to the supply voltage V_{BST} for low values of V_{BST} ($5V \leq V_{BST} \leq \sim 12V$). For $V_{BST} > 12V$, DRV is clamped internally to prevent it exceeding 15V. Below 12V, the minimum DRV pin voltage is 2.5V below V_{BST} .
 - DRV is switched to PGND by an NMOS transistor.
 - If t_{ON} exceeds t_{STALL} , the device forces DRV low to turn off the external switch and then initiate a restart cycle. During this phase, CTRL is grounded internally, and the COMP pin is switched to its nominal operating voltage before operation is allowed to resume. Restart cycles are repeated automatically until the operating conditions are such that normal operation can be sustained. If t_{OFF} exceeds t_{STALL} , the switch remains off until normal operation is possible.

Typical Characteristics

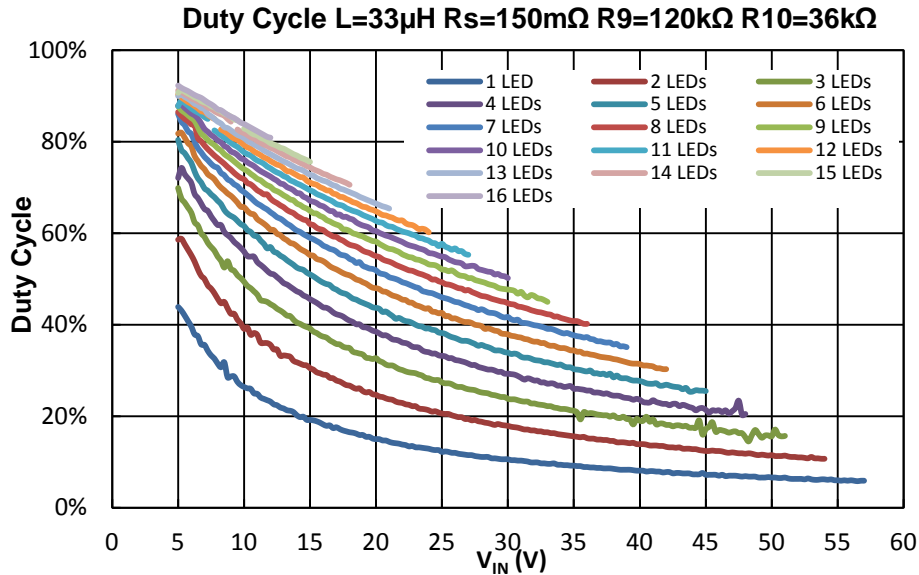
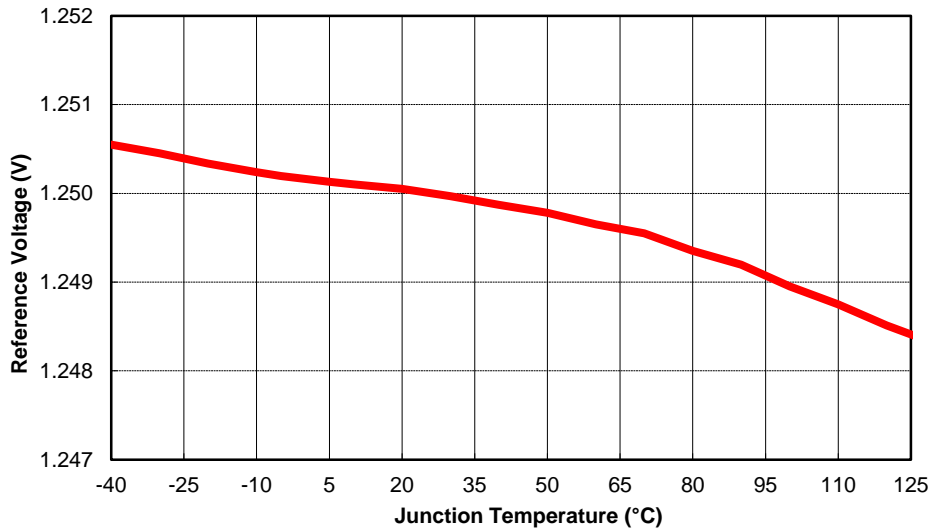
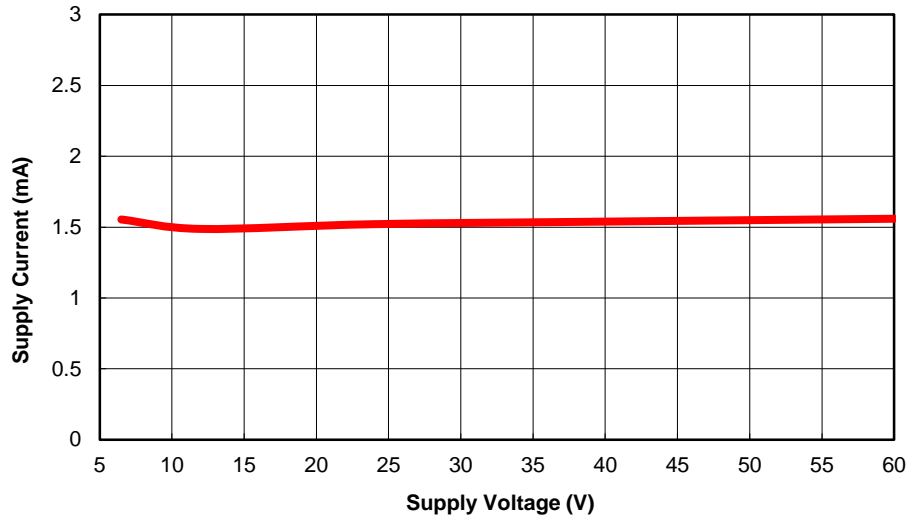

Typical Characteristics—Analog/PWM Dimming

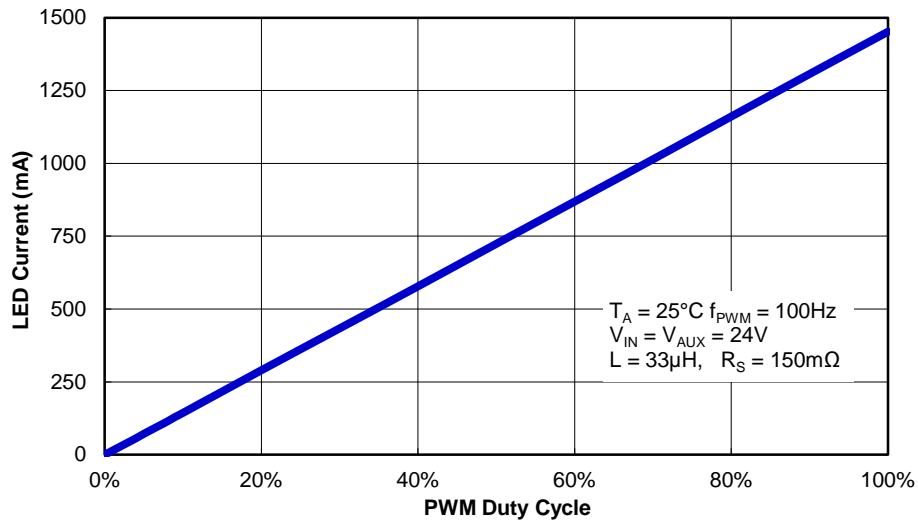
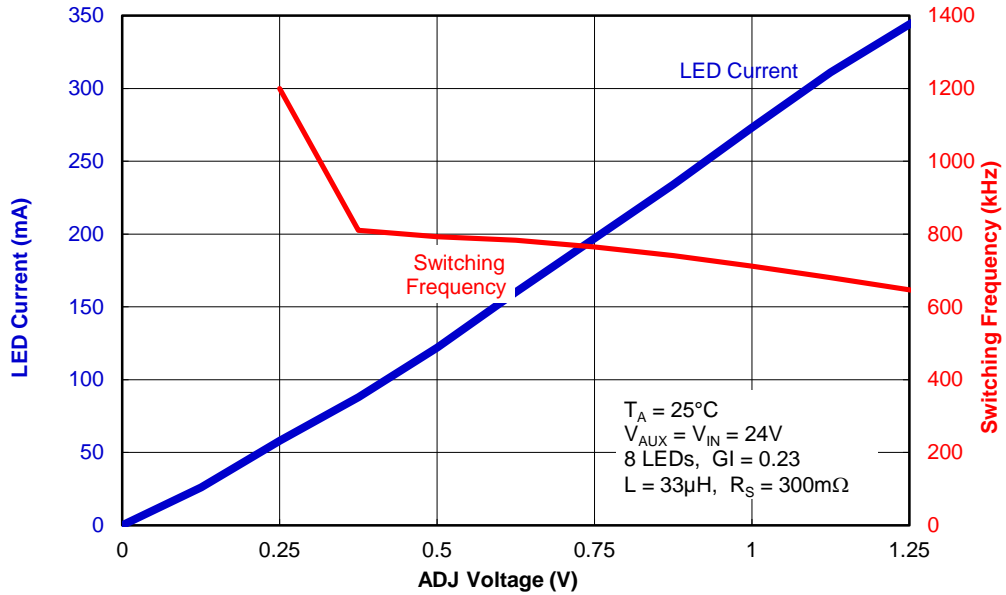

Typical Characteristics—Thermal Dimming

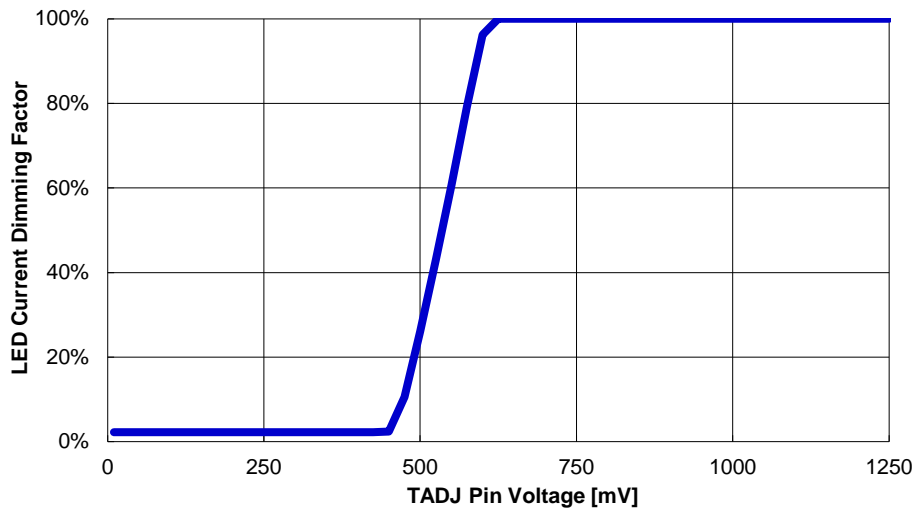

Typical Characteristics ($R_S = 150m\Omega$, $I_{LED} = 350mA$, $G_{LRATIO} = 0.23$)

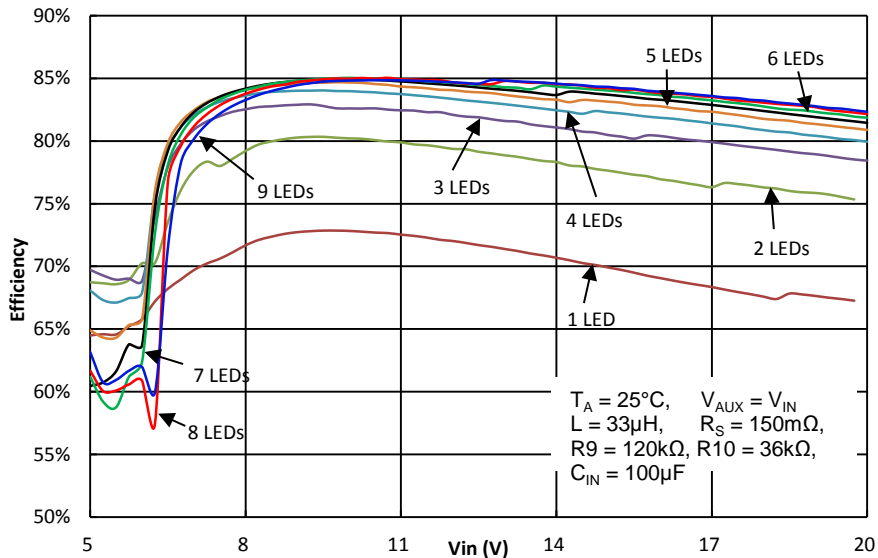
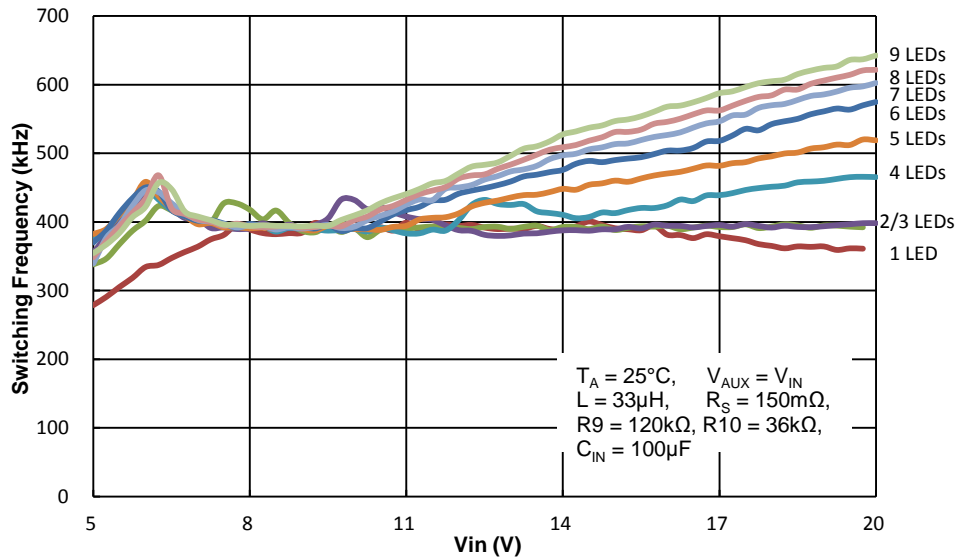
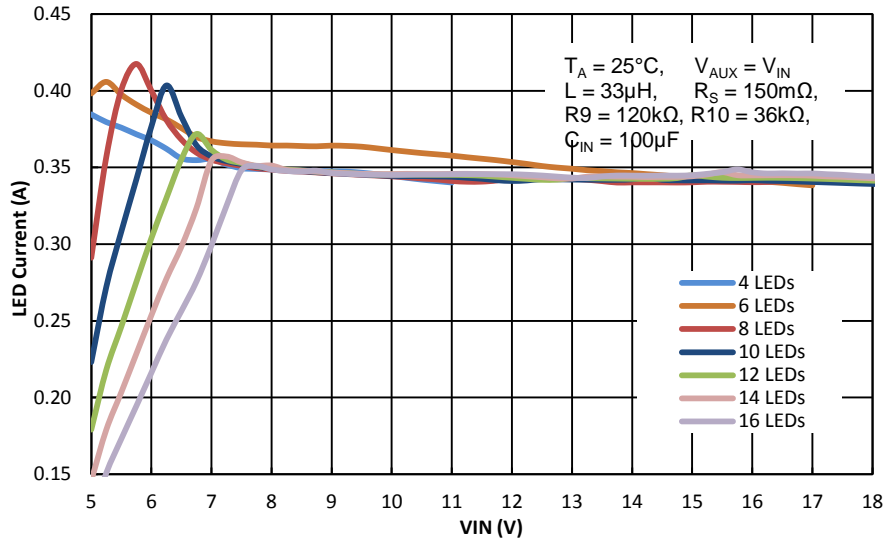

Typical Characteristics ($R_S = 150\text{m}\Omega$, $I_{LED} = 350\text{mA}$, $G_{RATIO} = 0.23$)

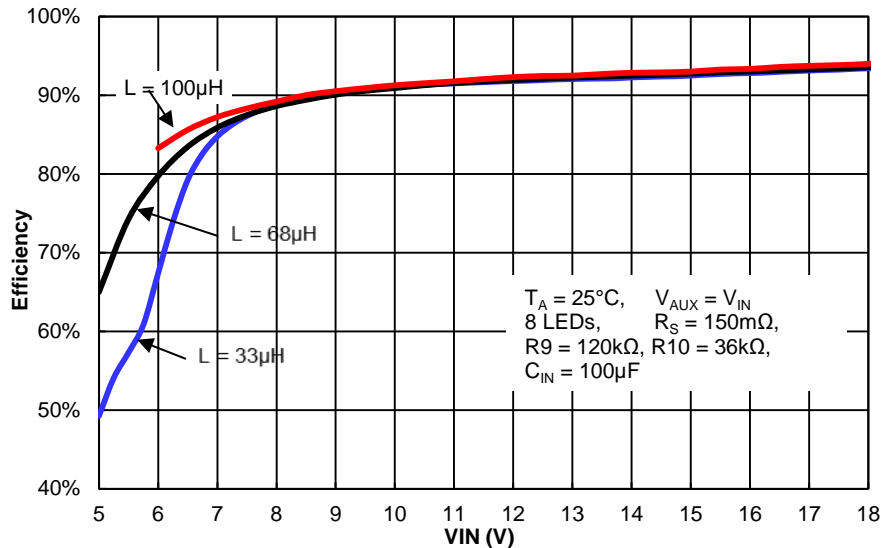
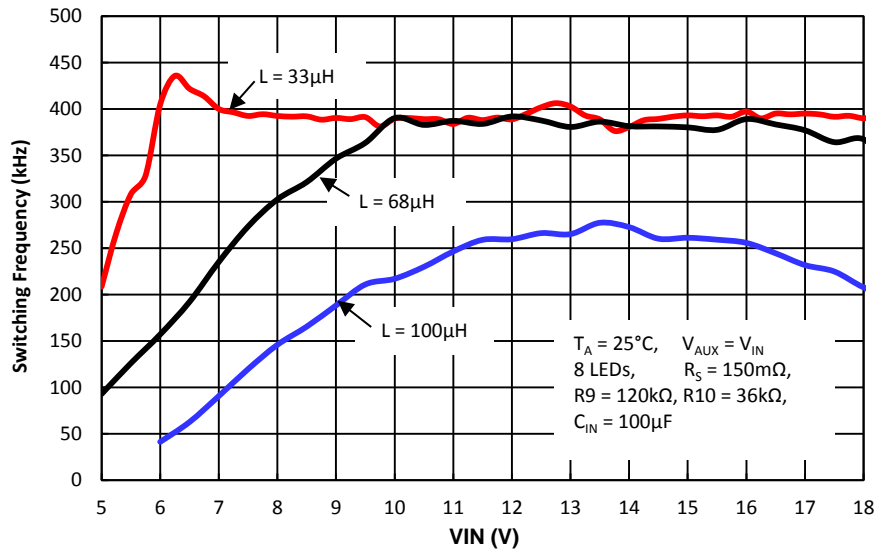
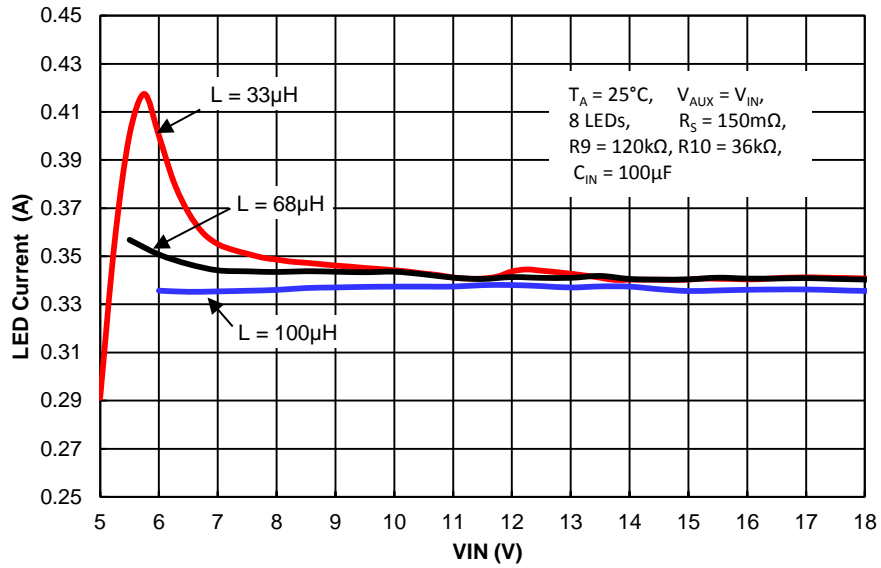

Typical Characteristics (8 LEDs, L = 33uH, GI_{RATIO} = 0.23)

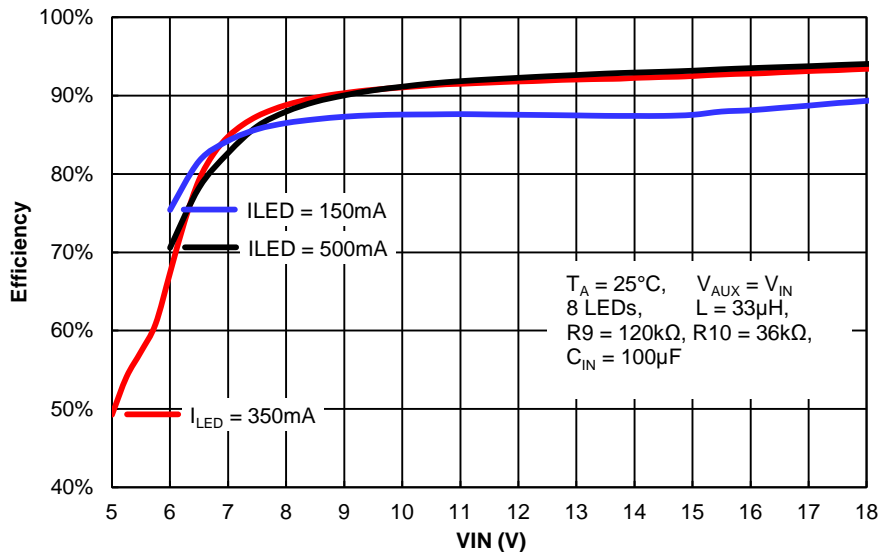
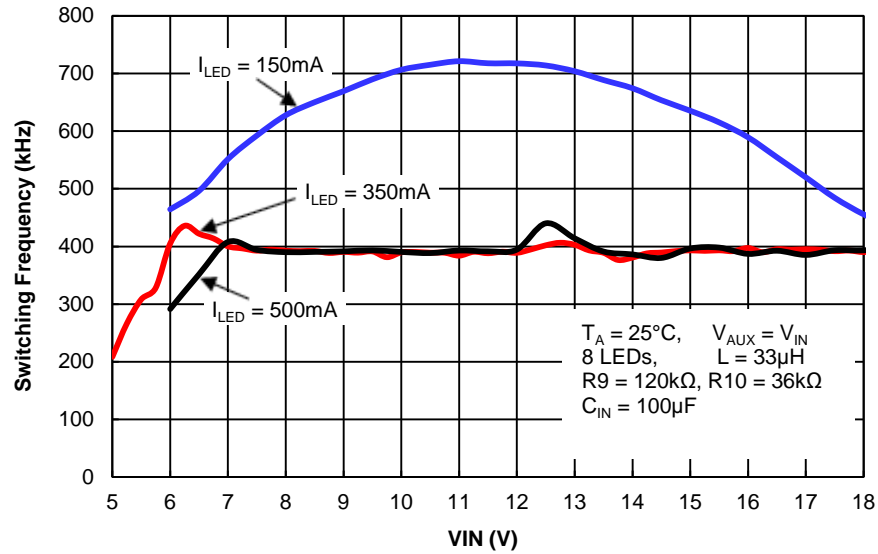
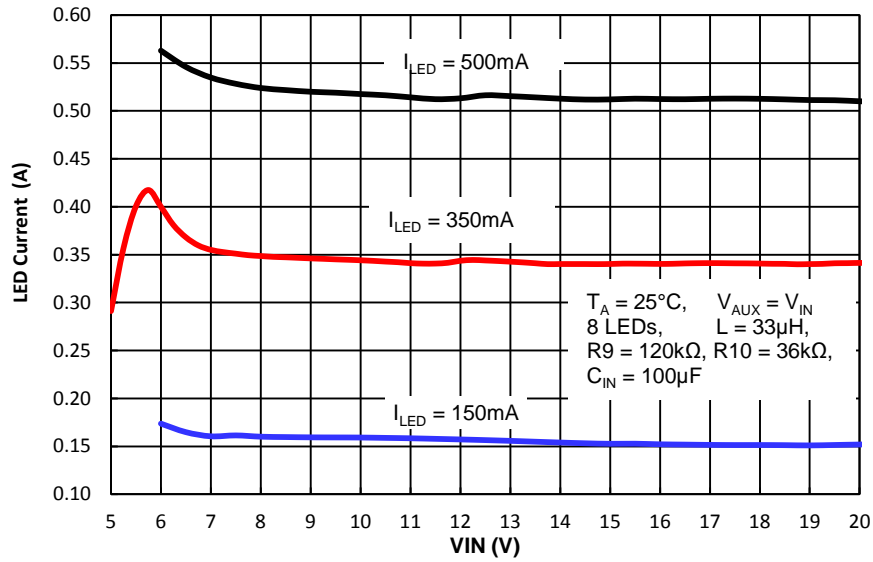

Typical Characteristics—Bootstrap Performance

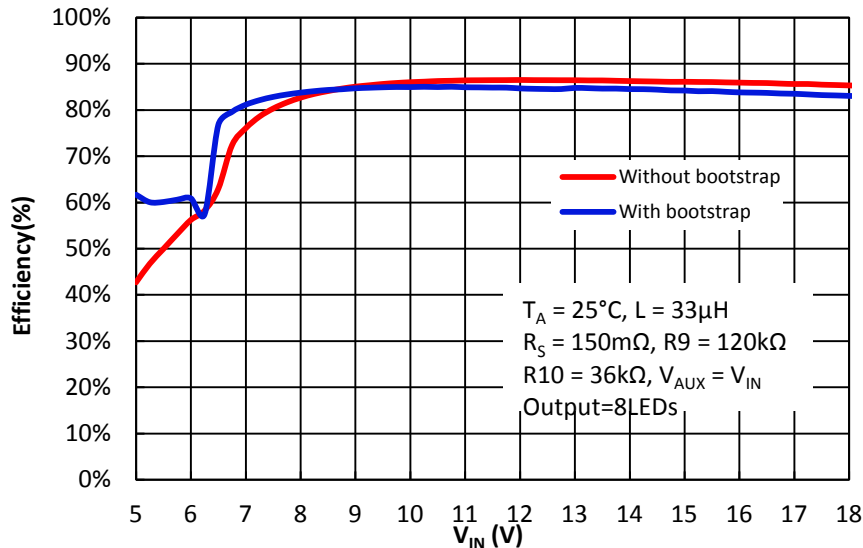
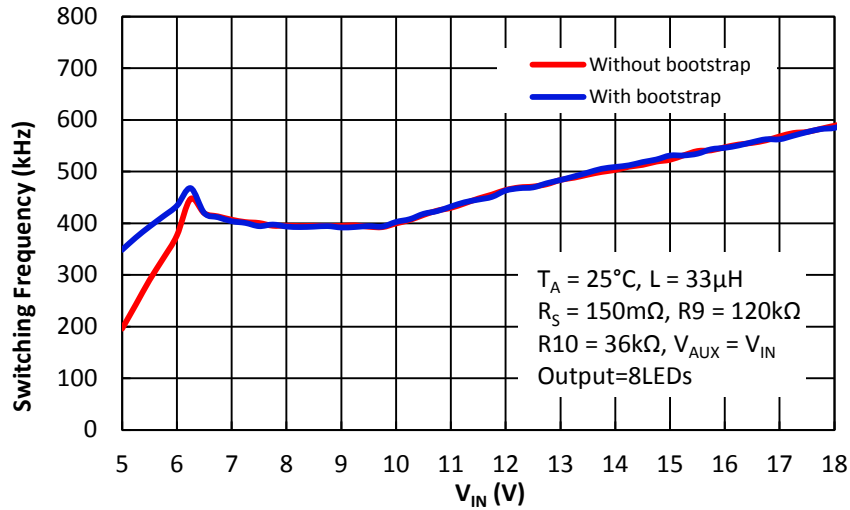
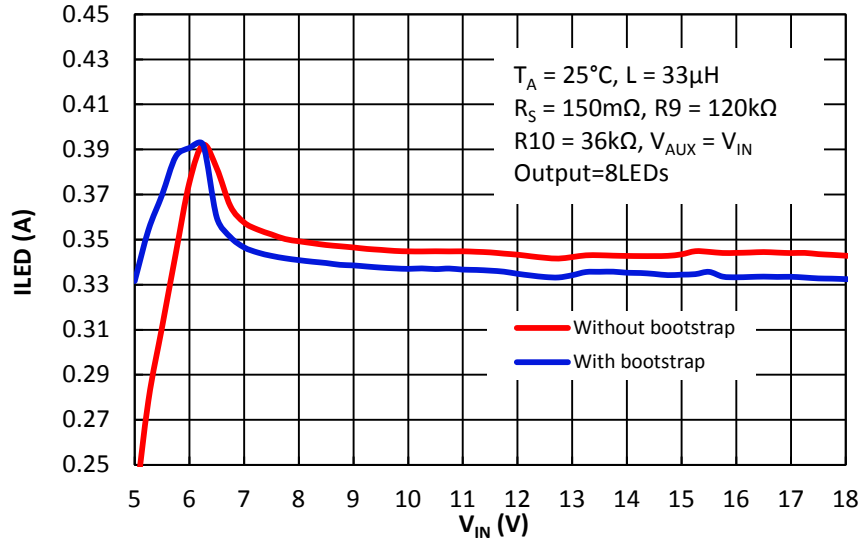

Application Information

The AL8871Q is a high-accuracy, hysteretic-inductive buck/boost/buck-boost controller designed to be used with an external NMOS switch for current-driving single or multiple series-connected LEDs. The device can be configured to operate in buck, boost, or buck-boost modes by suitable configuration of the external components as shown in the schematics.

Device Description

Resistor R_s connected between the two inputs of a current monitor within the control loop block senses the coil current. An output from the control loop drives the input of a comparator, which drives the gate of the external NMOS switch transistor Q1 via the internal gate driver. When the switch is on, the drain voltage of Q1 is near zero. Current flows from V_{IN} , via R_s , coil, and switch to ground. This current ramps up until an upper threshold value is reached (see Figure 3). At this point DRV goes low, the switch is turned off, and the drain voltage increases to the load voltage V_{LEDS} plus the forward voltage of D1 plus V_{IN} .

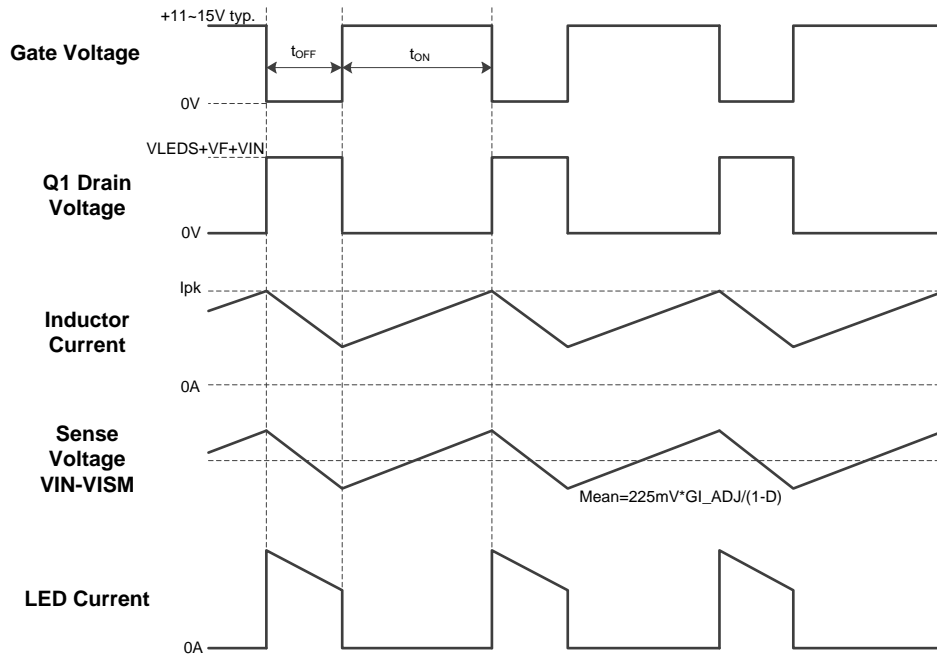

Figure 3. Operating Waveforms

Current flows via R_s , coil, D1, and LED back to V_{IN} . When the coil current ramps down to a lower threshold value, DRV goes high, the switch is turned on again, and the cycle of events repeats, which results in continuous oscillation.

The feedback loop adjusts the NMOS switch duty cycle to stabilize the LED current in response to changes in external conditions, including input voltage and load voltage. Loop compensation is achieved by a single external capacitor C2 connected between COMP and SGND. Note that in reality, a load capacitor C_{OUT} is used, so the LED current waveform shown is smoothed.

The average current in the sense resistor and coil, I_{RS} , is equal to the average of the maximum and minimum threshold currents, and the ripple current (hysteresis) is equal to the difference between the thresholds.

The average current in the LED, I_{LED} , is always less than I_{RS} . The feedback control loop adjusts the switch duty cycle, D, to achieve a set point at the sense resistor. This controls I_{RS} . During the interval t_{OFF} , the coil current flows through D1 and the LED load. During t_{ON} , the coil current flows through Q1—not the LEDs. Therefore, the set point is modified by D using a gating function to control I_{LED} indirectly. In order to compensate internally for the effect of the gating function, a control factor GI_CTRL is used. GI_CTRL is set by a pair of external resistors R_{GI1} (R10) and R_{GI2} (R9) (see Figure 4). This allows the sense voltage to be adjusted to an optimum level for power efficiency without significant error in the LED controlled current.

$$GI_CTRL = \left(\frac{R_{GI1}}{R_{GI1} + R_{GI2}} \right) \quad \text{Equation 1}$$

Application Information (continued)

The control loop sets the duty cycle, so the sense resistor current is:

$$I_{RS} = \left(\frac{0.225}{R_S} \right) \left(\frac{GI_CTRL}{1-D} \right) \left(\frac{V_{CTRL}}{V_{REF}} \right) \quad \text{Equation 2}$$

I_{RS} equals the coil current. The coil is only connected to the switch and the Schottky diode. The Schottky diode passes the LED current; therefore, the average LED current is the coil current multiplied by the Schottky diode duty cycle, 1-D.

$$I_{LED} = I_{RS} (1-D) = \left(\frac{0.225}{R_S} \right) GI_CTRL \left(\frac{V_{CTRL}}{V_{REF}} \right) \quad \text{Equation 3}$$

This shows that the LED current depends on the CTRL pin voltage, the reference voltage, and three resistor values (R_S , R_{GI1} , and R_{GI2}). It is independent of the input and output voltages.

If the CTRL pin is connected to the REF pin, it simplifies to:

$$I_{LED} = \left(\frac{0.225}{R_S} \right) GI_CTRL \quad \text{Equation 4}$$

Now I_{LED} is dependent only on the three resistor values.

Considering power dissipation and accuracy, it is useful to know how the mean sense voltage varies with input voltage and other parameters.

$$V_{RS} = I_{RS} R_S = 0.225 \left(\frac{GI_CTRL}{1-D} \right) \left(\frac{V_{CTRL}}{V_{REF}} \right) \quad \text{Equation 5}$$

This shows that the sense voltage varies with duty cycle.

Application Circuit Design

External component selection is driven by the characteristics of the load and the input supply because this will determine the kind of topology is used for the system. Component selection begins with the current setting procedure, the inductor/frequency setting, and the MOSFET selection. Finally after selecting the freewheeling diode and the output capacitor (if required), the application section covers the PWM dimming and thermal feedback. The full procedure is greatly accelerated by the web calculator spreadsheet, which includes fully automated component selection and is available on the Diodes website; however, the full calculation is also given here.

Please note the following particular feature of the web calculator. The GI ratio can be set for automatic calculation, or it can be fixed at a chosen value. When optimizing a design, it is best first to optimize for the chosen voltage range of most interest using the automatic setting. In order to subsequently evaluate performance of the circuit over a wider input voltage range, fix the GI ratio in the calculator input field, and set the desired input voltage range.

Some components depend upon the switching frequency and the duty cycle. The switching frequency is regulated by the AL8871Q to a large extent depending upon conditions. This is discussed later in this document when dealing with coil selection.

Duty Cycle Calculation

The duty cycle is a function of the input and output voltages. Approximately, the MOSFET switching duty cycle is:

$$D \approx \frac{V_{OUT}}{V_{OUT} + V_{IN}} \quad \text{Equation 6}$$

Because D must always be a positive number less than 1, these equations show that $V_{OUT} > 0$ or $V_{OUT} = 0$ or $V_{OUT} < V_{IN}$. This allows topology selection for the required voltage range. The more exact equation used in the web calculator is:

$$D \approx \frac{V_{OUT} + V_F + (I_{IN} + I_{OUT})(R_S + R_{COIL})}{V_{OUT} + V_{IN} + V_F - V_{DSON}} \quad \text{Equation 7}$$

Where:

V_F = Schottky diode forward voltage, estimated for the expected coil current, I_{COIL}

V_{DSON} = MOSFET drain source voltage in the ON condition (dependent on R_{DSON} and drain current = I_{COIL})

R_{COIL} = DC winding resistance of L1

Application Information (continued)

The additional terms are relatively small, so the exact equations only make a significant difference at lower operating voltages at the input and output, for example, low input voltage or a small number of LEDs connected in series. The estimates of V_F and $V_{DS(on)}$ depend on the coil current. The mean coil current, I_{COIL} is calculated as follows:

$$I_{COIL} = I_{IN} + I_{LED} \quad \text{Equation 8}$$

I_{LED} is the target LED current and is already known. I_{IN} is calculated with some accuracy later but can be estimated now from the electrical power efficiency. If the expected efficiency is roughly 90%, the output power P_{OUT} is 90% of the input power, P_{IN} , and the coil current is estimated as follows:

$$P_{OUT} \approx 0.9 P_{IN} \quad \text{or} \quad I_{LED} \times N \times V_{LED} \approx 0.9 I_{IN} \times V_{IN}$$

Where N is the number of LEDs connected in series, and V_{LED} is the forward voltage drop of a single LED at I_{LED} .

So,

$$I_{IN} \approx \frac{I_{LED} \times N \times V_{LED}}{0.9 V_{IN}} \quad \text{Equation 9}$$

Equation 9 can now be used to find I_{COIL} in **Equation 8**, which can then be used to estimate the small terms in **Equation 7**. This completes the calculation of duty cycle.

An initial estimate of duty cycle is required before choosing a coil. In **Equation 7**, the following approximations are recommended:

$$\begin{aligned} V_F &= 0.5V \\ I_{IN} \times (R_S + R_{COIL}) &= 0.5V \\ I_{OUT} \times (R_S + R_{COIL}) &= 0.5V \\ V_{DS(on)} &= 0.1V \\ (I_{IN} + I_{OUT})(R_S + R_{COIL}) &= 1.1V \end{aligned}$$

Then **Equation 7** becomes:

$$D \approx \frac{V_{OUT} + 1.6}{V_{OUT} + V_{IN} + 0.4} \quad \text{Equation 7a}$$

Setting the LED Current

The LED current requirement determines the choice of the sense resistor R_S . This also depends on the voltage on the CTRL pin and the voltage on the GI pin according to the topology required.

The CTRL pin can be connected directly to the internal 1.25V reference (V_{REF}) to define the nominal 100% LED current. The CTRL pin can also be driven with an external DC voltage between 125mV and 1.25V to adjust the LED current proportionally between 10% and 100% of the nominal value.

The divider ratio GI_CTRL is set less than 0.65V typically for optimized operation. This 0.65V threshold varies in proportion to V_{CTRL} .

CTRL and GI are high-impedance inputs within their normal operating voltage ranges. An internal 1.3V clamp protects the device against excessive input voltage and limits the maximum output current to approximately 4% above the maximum current set by V_{REF} if the maximum input voltage is exceeded.

Application Information (continued)

The LED current depends upon the resistors, R_S , R_{GI1} , and R_{GI2} as in **Equations 1** and **3**. There is more than one degree of freedom. That is to say, there is not a unique solution. From **Equation 3**,

$$R_S = \left(\frac{0.225}{I_{LED}} \right) G_{I_CTRL} \left(\frac{V_{CTRL}}{V_{REF}} \right) \quad \text{Equation 10}$$

If CTRL is connected to REF, this becomes:

$$R_S = \left(\frac{0.225}{I_{LED}} \right) G_{I_CTRL} \quad \text{Equation 11}$$

G_{I_CTRL} is given by **Equation 1**, repeated here for convenience:

$$G_{I_CTRL} = \left(\frac{R_{GI1}}{R_{GI1} + R_{GI2}} \right)$$

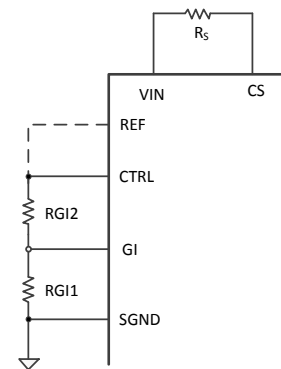

Figure 4. Setting LED Current

Note that from considerations of AL8871Q input bias current, the recommended limits for R_{GI1} are:

$$22k\Omega < R_{GI1} < 100k\Omega \quad \text{Equation 12}$$

The additional degree of freedom allows the selection of G_{I_CTRL} within limits, but this can affect overall performance a little. As mentioned above, the working voltage range at the GI pin is restricted. The permitted range of G_{I_CTRL} is

$$0.2 < G_{I_CTRL} < 0.5 \quad \text{Equation 13}$$

The mean voltage across the sense resistor is

$$V_{RS} = I_{COIL} R_S \quad \text{Equation 14}$$

Note that if G_{I_CTRL} is made larger, these equations show that R_S is increased and V_{RS} is increased. Therefore, for the same coil current, the dissipation in R_S is increased. So, in some cases, it is better to minimize G_{I_CTRL} . However, consider **Equation 5**. If CTRL is connected to REF, this becomes:

$$V_{RS} = 0.225 \left(\frac{G_{I_CTRL}}{1-D} \right)$$

This shows that V_{RS} becomes smaller than 225mV if $G_{I_CTRL} < 1 - D$. If D is also small, V_{RS} can become too small. For example if $D = 0.2$, and G_{I_CTRL} is the minimum value of 0.2, V_{RS} becomes $0.225 \times 0.2 / 0.8 = 56.25$ mV. This increases the LED current error due to small offsets in the system, such as mV drop in the copper printed wiring circuit, or offset uncertainty in the AL8871Q. Now if G_{I_CTRL} is increased to 0.4 or 0.5, V_{RS} is increased to a value greater than 100mV.

This gives small enough I_{LED} error for most practical purposes. Satisfactory operation will be obtained if V_{RS} is more than about 80mV. This means G_{I_CTRL} should be greater than $(1-D_{MIN}) \times 80/225 = (1 - D_{MIN}) \times 0.355$.

There is also a maximum limit on V_{RS} , which gives a maximum limit for G_{I_CTRL} . If V_{RS} exceeds approximately 300mV, or 133% of 225mV, the STATUS output can indicate an overcurrent condition. This will happen for larger D_{MAX} . Therefore, together with the requirement of **Equation 9**, the recommended range for G_{I_CTRL} is

$$0.355 (1-D_{MIN}) < G_{I_CTRL} < 1.33 (1-D_{MAX}) \quad \text{Equation 15}$$

An optimum compromise for G_{I_CTRL} has been suggested. For example.

$$G_{I_CTRL_AUTO} = 1 - D_{MAX} \quad \text{Equation 16}$$

This value has been used for the *Automatic* setting of the web calculator. If $1 - D_{MAX}$ is less than 0.2, G_{I_CTRL} is set to 0.2. If $1 - D_{MAX}$ is greater than 0.5 then G_{I_CTRL} is set to 0.5.

Application Information (continued)

Once GI_CTRL is selected, a value of R_{GI1} can be selected from **Equation 8**. Then R_{GI2} is calculated as follows, rearranging **Equation 1**:

$$R_{GI2} = R_{GI1} \left(\frac{1-GI_CTRL}{GI_CTRL} \right) \quad \text{Equation 17}$$

For example driving 12 LEDs at a current of 350mA from a 12V supply, each LED has a forward voltage of 3.2V at 350mA, so V_{out} = 3.2 × 12 = 38.4V. The duty cycle is approximately

$$\frac{(V_{OUT}-V_{IN})}{V_{OUT}} = \frac{(38.4-12)}{38.4} = 0.6875$$

From **Equation 12**, we set GI_CTRL to 1 – D = 0.3125.

IF R_{GI1} = 33kΩ, then from **Equation 3**, R_{GI2} = 33000 × (1 - 0.3125) / 0.3125 = 72.6kΩ. Select the preferred value R_{GI2} = 75kΩ. Now GI_CTRL is adjusted to the new value using **Equation 1**.

$$GI_CTRL = \left(\frac{R_{GI1}}{R_{GI1} + R_{GI2}} \right) = \frac{33k}{33k + 75k} = 0.305$$

Now calculate R_S from **Equation 6**. Assume CTRL is connected to REF.

$$R_S = \left(\frac{0.225}{I_{LED}} \right) GI_CTRL \left(\frac{V_{CTRL}}{V_{REF}} \right) = \frac{0.225}{0.35} * 0.305 = 0.196 \Omega$$

A preferred value of R_S = 0.2Ω gives the desired LED current with an error of 2% due to the preferred value selection.

Table 1 shows typical resistor values used to determine the GI_CTRL ratio with E24 series resistors.

Table 1

GI ratio	R _{GI1}	R _{GI2}
0.2	30kΩ	120kΩ
0.25	33kΩ	100kΩ
0.3	39kΩ	91kΩ
0.35	30kΩ	56kΩ
0.4	100kΩ	150kΩ
0.45	51kΩ	62kΩ
0.5	30kΩ	30kΩ

This completes the LED current setting.

Application Information (continued)

Inductor Selection and Frequency Control

The selection of the inductor coil, L1, requires knowledge of the switching frequency and current ripple and depends on the duty cycle to some extent. In the hysteretic converter, the frequency depends upon the input and output voltages and the switching thresholds of the current monitor. The peak-to-peak coil current is adjusted by the AL8871Q to control the frequency to a fixed value. This is done by controlling the switching thresholds within particular limits. This effectively reduces much of the overall frequency range for a given input voltage range. Where the input voltage range is not excessive, the frequency is regulated to approximately 390kHz. This is helpful in terms of EMC and other system requirements. **Figure 5** shows practical results of switching frequency driving eight LEDs at 350mA.

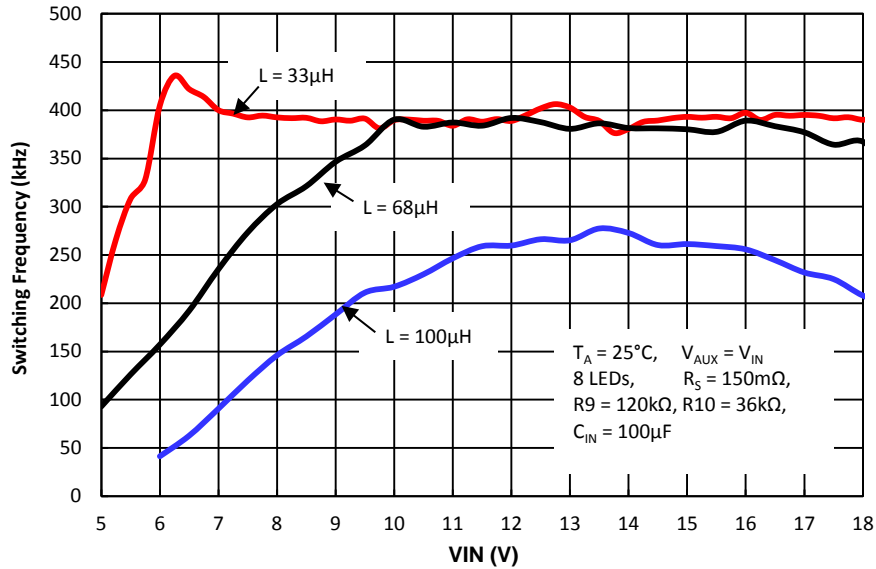

Figure 5. Frequency vs. VIN LED Driver with 350mA LED Current and Various Inductor Values

For larger input voltage variation, or when the choice of coil inductance is not optimum, the switching frequency can depart from the regulated value, but the regulation of LED current remains successful. If desired, the frequency can to some extent be increased by using a smaller inductor, or decreased using a larger inductor. The web calculator evaluates the frequency across the input voltage range and the effect of this upon power efficiency and junction temperatures.

Determination of the input voltage range for which the frequency is regulated may be required. This calculation is very involved and is not given here. However, the performance in this respect can be evaluated within the web calculator for the chosen inductance.

The inductance is given as follows in terms of peak-to-peak ripple current in the coil, ΔI_L , and the MOSFET on time, t_{ON} .

$$L1 = \{V_{IN} - (I_{IN} + I_{OUT})(R_{DS(ON)} + R_{COIL} + R_S)\} \times \frac{t_{ON}}{\Delta I_L} \quad \text{Equation 18}$$

Therefore In order to calculate L1, I_{IN} , t_{ON} , and ΔI_L must be found. The effects of the resistances are small and are estimated. I_{IN} is estimated from **Equation 9**. t_{ON} is related to switching frequency, f, and duty cycle, D, as follows:

$$t_{ON} = \frac{D}{f} \quad \text{Equation 19}$$

As the regulated frequency is known, and D from **Equation 7**, or the approximation **Equation 7a**, is found, this calculation of t_{ON} is possible.

Application Information (continued)

The AL8871Q sets the ripple current, ΔI_L , to between nominally 10% and 30% of the mean coil current, I_{COIL} , which is found from **Equation 8**. The device adjusts the ripple current within this range in order to regulate the switching frequency. A ΔI_L value of 20% of I_{COIL} must be used to find an inductance, which is optimized for the input voltage range. The range of ripple current control is also modulated by other circuit parameters as follows.

$$\begin{aligned}\Delta I_{LMAX} &= \left\{0.06 + 0.24 \left(\frac{V_{ADJ}}{V_{REF}}\right)\right\} \times \frac{1-D}{GI_{ADJ}} \times I_{COIL} \\ \Delta I_{LMIN} &= \left\{0.02 + 0.08 \left(\frac{V_{ADJ}}{V_{REF}}\right)\right\} \times \frac{1-D}{GI_{ADJ}} \times I_{COIL} \\ \Delta I_{LMID} &= \left\{0.04 + 0.16 \left(\frac{V_{ADJ}}{V_{REF}}\right)\right\} \times \frac{1-D}{GI_{ADJ}} \times I_{COIL}\end{aligned}\quad \text{Equation 20}$$

If ADJ is connected to REF, this simplifies to

$$\begin{aligned}\Delta I_{LMAX} &= 0.3 \times \frac{1-D}{GI_{ADJ}} \times I_{COIL} \\ \Delta I_{LMIN} &= 0.1 \times \frac{1-D}{GI_{ADJ}} \times I_{COIL} \\ \Delta I_{LMID} &= 0.2 \times \frac{1-D}{GI_{ADJ}} \times I_{COIL}\end{aligned}\quad \text{Equation 20a}$$

Where ΔI_{LMID} is the value of we must use in **Equation 18**. The inductance value is now established.

The chosen coil must saturate at a current greater than the peak sensed current. This saturation current is the DC current for which the inductance has decreased by 10% compared to the low current value.

Assuming $\pm 10\%$ ripple current, the peak current can be found from **Equation 8**, which is adjusted for ripple current:

$$I_{COILPEAK} = 1.1 I_{INMAX} + I_{LED} \quad \text{Equation 21}$$

Where I_{INMAX} is the value of I_{IN} at minimum V_{IN} . The mean current rating is also a factor, but normally the saturation current is the limiting factor.

LED Current Dimming

The AL8871Q has three dimming methods for reducing the average LED current:

1. DC dimming using the CTRL pin
2. PWM dimming using the PWM pin
3. DC dimming for thermal protection using the NTC pin

DC or Analog Dimming

The AL8871Q has a clamp on the CTRL pin to prevent overdriving of the LED current, which results in applying the maximum voltage to internal circuitry as the reference voltage. This provides a 10:1 dynamic range of DC LED current adjustment.

The equation for DC dimming of the LED current is approximately:

$$I_{LED_DIM} = I_{LED_NOM} \left(\frac{V_{CTRL}}{V_{REF}}\right)$$

Where:

- I_{LED_DIM} is the dimmed LED current
- I_{LED_NOM} is the LED current with $V_{CTRL} = 1.25V$

One consequence of DC dimming is as the CTRL pin voltage reduces, the sense voltage also be reduces, which has an impact on accuracy and switching frequency especially at lower CTRL pin voltages.

Application Information (continued)

PWM Output Current Control & Dimming

The AL8871Q has a dedicated PWM dimming input that allows a wide-dimming frequency range from 100Hz to 1kHz with up to 1000:1 resolution; however, higher dimming frequencies can be used at the expense of dimming dynamic range and accuracy.

Typically, for a PWM frequency of 1kHz, the error on the current linearity is lower than 5%; in particular, the accuracy is better than 1% for PWM from 5% to 100%. For a PWM frequency of 100Hz, the error on the current linearity is lower than 2.5%; it becomes negligible for PWM greater than 5%.

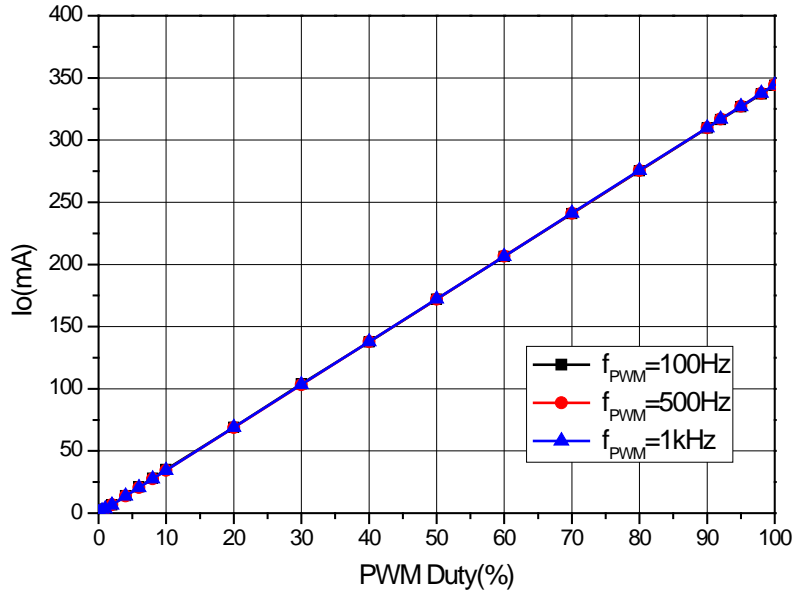

Figure 7. LED Current Linearity and Accuracy with PWM Dimming

The PWM pin is designed to be driven by both 3.3V and 5V logic levels and, as such, does not require open collector/drain drive. It can also be driven by an open drain/collector transistor. In this case the designer can either use the internal pull-up network or an external pull-up network in order to speed-up PWM transitions.

LED current can be adjusted digitally, by applying a low frequency PWM logic signal to the PWM pin to turn the controller on and off. This will produce an average output current proportional to the duty cycle of the control signal. During PWM operation, the device remains powered up and only the output switch is gated by the control signal.

The PWM signal can achieve extremely high LED current resolution. In fact, dimming down from 100% to 0, a minimum pulse width of 2µs can be achieved resulting in very high accuracy. While the maximum recommended pulse is for the PWM signal is 10ms.

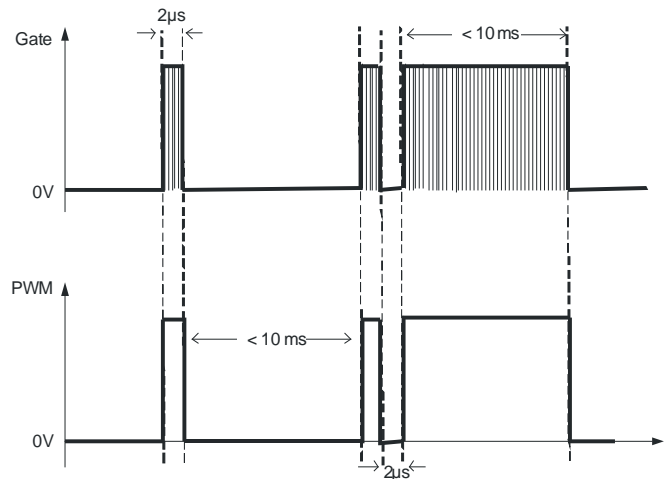

Figure 8. PWM Dimming Minimum and Maximum Pulse

The device can be put in standby by taking the PWM pin to ground, or pulling it to a voltage below 0.4V with a suitable open collector NPN or open drain NMOS transistor, for a time exceeding 15ms (nominal). In the shutdown state, most of the circuitry inside the device is switched off and residual quiescent current will be typically 90µA. In particular, the Status pin will go down to GND while the FLAG and REF pins will stay at their nominal values.

Application Information (continued)

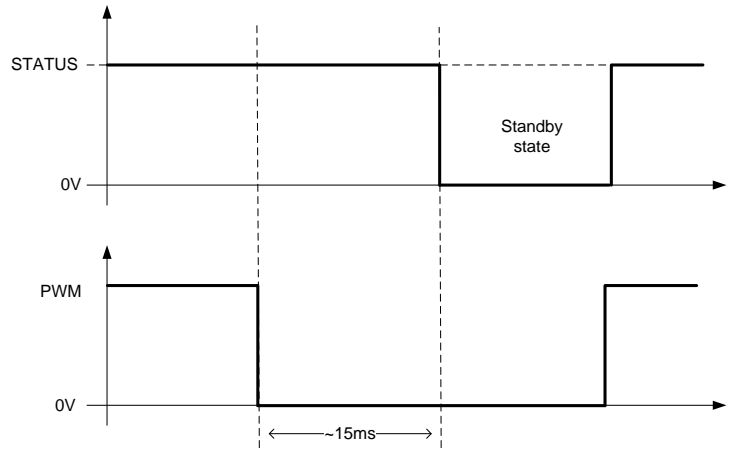

Figure 9. Stand-by State from PWM Signal

Thermal Control of LED Current

For thermal control of the LEDs, the AL8871Q monitors the voltage on the NTC pin and reduces output current if the voltage on this pin falls below 625mV. An external NTC thermistor and resistor can therefore be connected as shown below to set the voltage on the NTC pin to 625mV at the required temperature threshold. This will give 100% LED current below the threshold temperature and a falling current above it as shown in the graph. The temperature threshold can be altered by adjusting the value of R_{TH} and/or the thermistor to suit the requirements of the chosen LED.

The Thermal Control feature can be disabled by connecting NTC directly to REF.

Here is a simple procedure to design the thermal feedback circuit:

- 1) Select the temperature threshold $T_{THRESHOLD}$ at which the current must start to decrease
- 2) Select the Thermistor TH1 (both resistive value at +25°C and beta)
- 3) Select the value of the resistor R_{TH} as $R_{TH} = TH$ at $T_{THRESHOLD}$

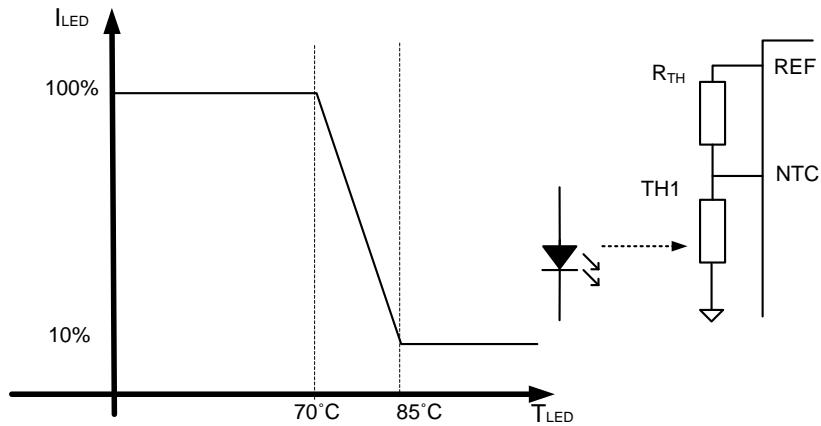

Thermal network response:
 $R_{TH} = 1.8k\Omega$ and $TH1=10k\Omega$ (beta =3900)

Figure 10. Thermal Feedback Network

Applications Information (Cont.)

The thermistor resistance, R_T , at a temperature of T degrees Kelvin is given by

$$R_T = R_R e^{B\left(\frac{1}{T} - \frac{1}{T_R}\right)}$$

Where:

R_R is the thermistor resistance at the reference temperature, T_R

T_R is the reference temperature, in Kelvin, normally $273 + 25 = 298K (+25^\circ C)$

B is the "beta" value of the thermistor.

For example:

- 1) Temperature threshold $T_{THRESHOLD} = 273 + 70 = 343K (+70^\circ C)$
- 2) $TH1 = 10k\Omega$ at $+25^\circ C$ and $B = 3900 \rightarrow R_T = 1.8k\Omega @ 70^\circ C$
- 3) $R_{TH} = R_T$ at $T_{THRESHOLD} = 1.8k\Omega$

FLAG/STATUS Outputs

The FLAG/STATUS outputs provide a warning of extreme operating or fault conditions. FLAG is an open-drain logic output, which is normally off, but switches low to indicate that a warning, or fault condition exists. STATUS is a DAC output, which is normally high (4.5V), but switches to a lower voltage to indicate the nature of the warning/fault.

Conditions monitored, the method of detection and the nominal STATUS output voltage are given in the following table (Note 17):

Table 2

Warning/Fault Condition	Severity (Note 18)	Monitored Parameters	FLAG	Nominal STATUS Voltage
Normal Operation	-	-	H	4.5V
Supply Undervoltage	1	$V_{AUX} < 5.0V$	L	4.5V
	2	$V_{IN} < 5.6V$	L	< 3.6V
Output Current out of Regulation (Note 19)	2	V_{SHP} outside normal voltage range	L	3.6V
Driver Stalled with Switch 'on', or 'off' (Note 20)	2	t_{ON} , or $t_{OFF} > 100\mu s$	L	3.6V
Device Temperature above Maximum Recommended Operating Value	3	$T_J > +125^\circ C$	L	1.8V
Sense Resistor Current I_{RS} above Specified Maximum	4	$V_{SENSE} > 0.3V$	L	0.9V

- Notes:
17. These STATUS pin voltages apply for an input voltage, V_{IN} , of $7.5V < V_{IN} < 60V$. Below 7.5V the STATUS pin voltage levels reduce and therefore may not report the correct status. For $5.4V < V_{IN} < 7.5V$ the flag pin still reports an error by going low. At low V_{IN} in Boost and Buck-boost modes an overcurrent status may be indicated when operating at high boost ratios - this due to the feedback loop increasing the sense voltage.
 18. Severity 1 denotes lowest severity.
 19. This warning will be indicated if the output power demand is higher than the available input power; the loop may not be able to maintain regulation.
 20. This warning will be indicated if the gate pin stays at the same level for greater than $100\mu s$ (e.g. the output transistor cannot pass enough current to reach the upper switching threshold).

Applications Information (Cont.)

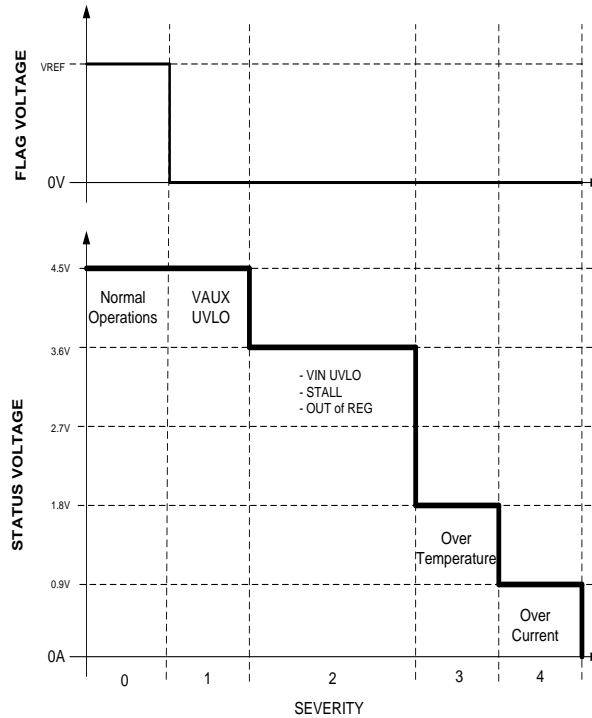

Figure 11. Status levels

In the event of more than one fault/warning condition occurring, the higher severity condition will take precedence. E.g. ‘Excessive coil current’ and ‘Out of regulation’ occurring together will produce an output of 0.9V on the STATUS pin.

If $V_{CTR} > 1.7V$, V_{SENSE} may be greater than the excess coil current threshold in normal operation and an error will be reported. Hence, STATUS and FLAG are only guaranteed for $V_{CTR} \leq V_{REF}$.

Diagnostic signals should be ignored during the device start-up for $100\mu s$. The device start up sequence will be initiated both during the first power-on of the device or after the PWM signal is kept low for more than 15ms, initiating the standby state of the device.

In particular, during the first $100\mu s$ the diagnostic is signaling an overcurrent then an out-of-regulation status. These two events are due to the charging of the inductor and are not true fault conditions.

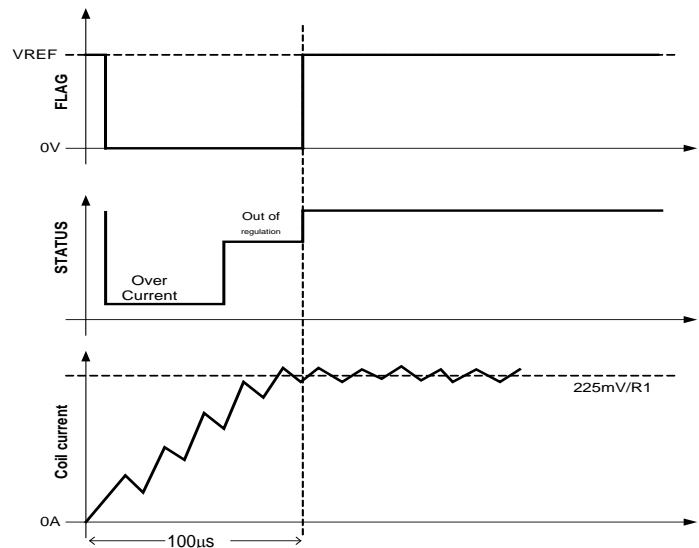

Figure 12. Diagnostic during Start-up

Applications Information (Cont.)

RC Snubber

Snubber is a form of circuit protection against voltage spikes, ringing and oscillation effects. Snubber works by either clamping voltage spikes but not altering the ringing frequency or does the same function. Snubber circuits are needed to limit the rate of change in voltage or current (di/dt or dv/dt) and over voltage during turn-on and turn-off. These are placed across the semiconductor devices for protection as well as to improve the system EMI performance.

The RC snubber across MOSFET should be adjusted according to different applications, generally the recommended value for RC snubber:

- R1: 10 ohm~ 1K ohm
- C1: 100 pF~ several nF
- Typically 100 ohm + 470pF

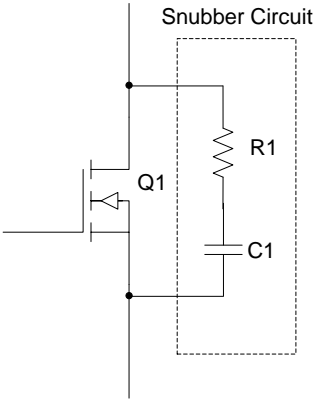

Overtemperature Shutdown

The AL8871Q incorporates an overtemperature shutdown circuit to protect against damage caused by excessive die temperature. A warning signal is generated on the STATUS output when die temperature exceeds +125°C nominal, and the output is disabled when die temperature exceeds +150°C nominal. Normal operation resumes when the device cools back down to +125°C.

Ordering Information

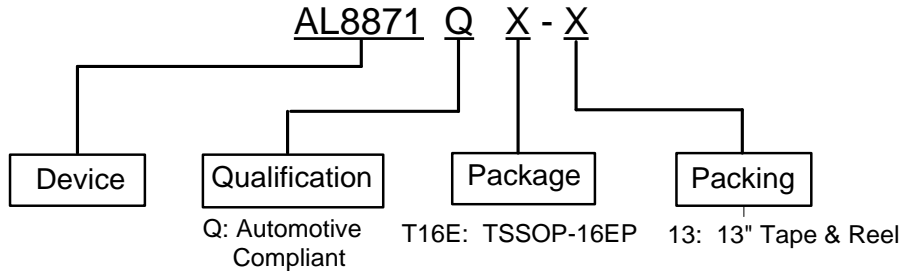

Part Number	Package Code	Package	Tape and Reel	
			Quantity	Part Number Suffix
AL8871QT16E-13	T16E	TSSOP-16EP	2500/Tape & Reel	-13

Marking Information

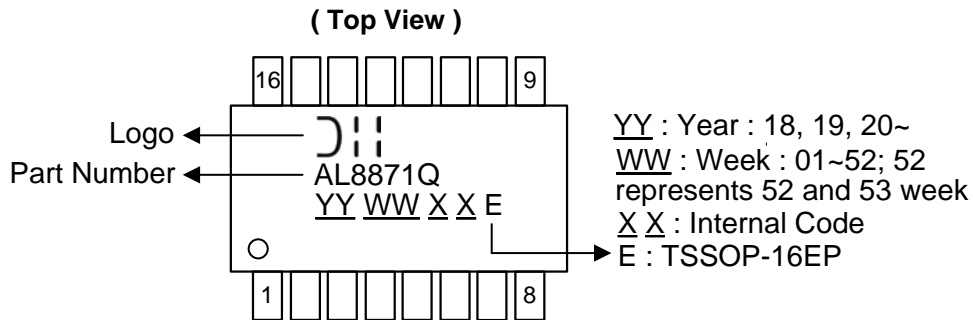

Device	Package	Identification Code
AL8871QT16E-13	TSSOP-16EP	-

Package Outline Dimensions (All dimensions in mm.)

Please see <http://www.diodes.com/package-outlines.html> for the latest version.

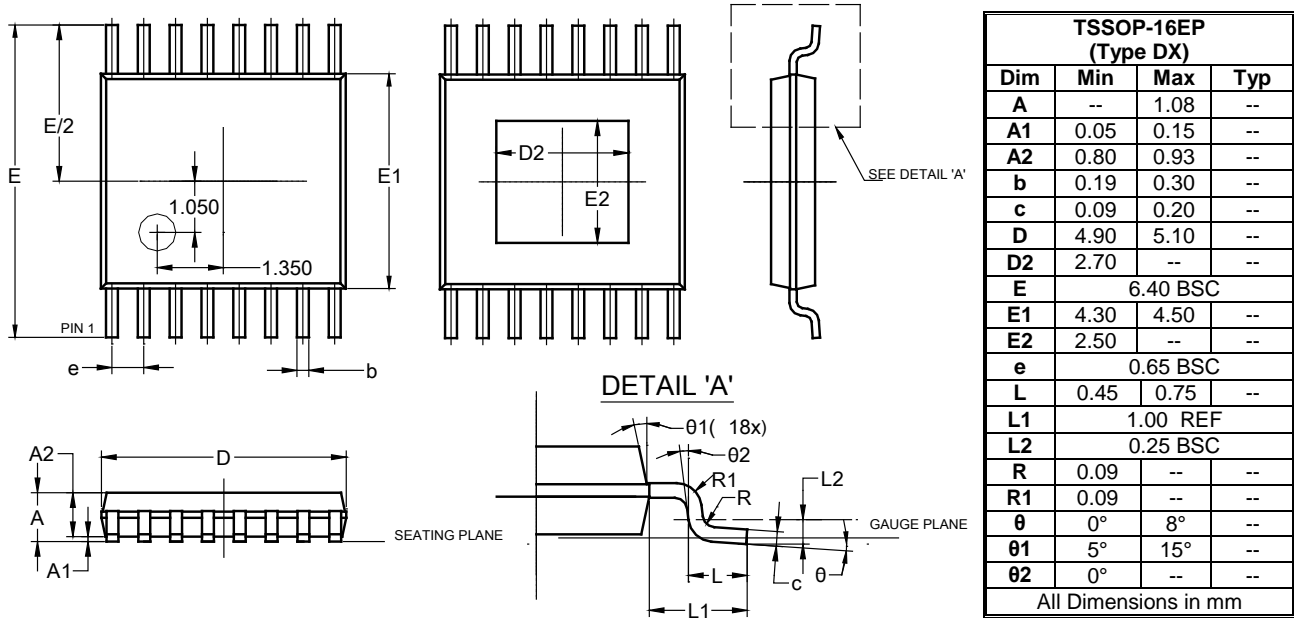

Suggested Pad Layout

Please see <http://www.diodes.com/package-outlines.html> for the latest version.

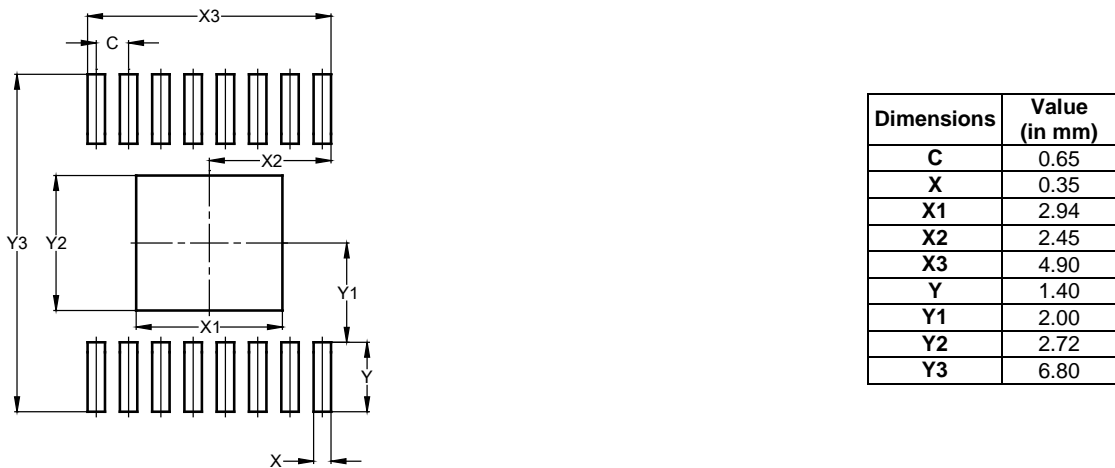

Mechanical Data

- Moisture Sensitivity: MSL Level 1 per JESD22-A113
- Terminals: Finish – Sn plated, Solderable per JESD22-B102 ③
- Weight: 0.055 grams (Approximate)

IMPORTANT NOTICE

DIODES INCORPORATED MAKES NO WARRANTY OF ANY KIND, EXPRESS OR IMPLIED, WITH REGARDS TO THIS DOCUMENT, INCLUDING, BUT NOT LIMITED TO, THE IMPLIED WARRANTIES OF MERCHANTABILITY AND FITNESS FOR A PARTICULAR PURPOSE (AND THEIR EQUIVALENTS UNDER THE LAWS OF ANY JURISDICTION).

Diodes Incorporated and its subsidiaries reserve the right to make modifications, enhancements, improvements, corrections or other changes without further notice to this document and any product described herein. Diodes Incorporated does not assume any liability arising out of the application or use of this document or any product described herein; neither does Diodes Incorporated convey any license under its patent or trademark rights, nor the rights of others. Any Customer or user of this document or products described herein in such applications shall assume all risks of such use and will agree to hold Diodes Incorporated and all the companies whose products are represented on Diodes Incorporated website, harmless against all damages.

Diodes Incorporated does not warrant or accept any liability whatsoever in respect of any products purchased through unauthorized sales channel. Should Customers purchase or use Diodes Incorporated products for any unintended or unauthorized application, Customers shall indemnify and hold Diodes Incorporated and its representatives harmless against all claims, damages, expenses, and attorney fees arising out of, directly or indirectly, any claim of personal injury or death associated with such unintended or unauthorized application.

Products described herein may be covered by one or more United States, international or foreign patents pending. Product names and markings noted herein may also be covered by one or more United States, international or foreign trademarks.

This document is written in English but may be translated into multiple languages for reference. Only the English version of this document is the final and determinative format released by Diodes Incorporated.

LIFE SUPPORT

Diodes Incorporated products are specifically not authorized for use as critical components in life support devices or systems without the express written approval of the Chief Executive Officer of Diodes Incorporated. As used herein:

A. Life support devices or systems are devices or systems which:

1. are intended to implant into the body, or
2. support or sustain life and whose failure to perform when properly used in accordance with instructions for use provided in the labeling can be reasonably expected to result in significant injury to the user.

B. A critical component is any component in a life support device or system whose failure to perform can be reasonably expected to cause the failure of the life support device or to affect its safety or effectiveness.

Customers represent that they have all necessary expertise in the safety and regulatory ramifications of their life support devices or systems, and acknowledge and agree that they are solely responsible for all legal, regulatory and safety-related requirements concerning their products and any use of Diodes Incorporated products in such safety-critical, life support devices or systems, notwithstanding any devices- or systems-related information or support that may be provided by Diodes Incorporated. Further, Customers must fully indemnify Diodes Incorporated and its representatives against any damages arising out of the use of Diodes Incorporated products in such safety-critical, life support devices or systems.

Copyright © 2020, Diodes Incorporated

www.diodes.com

X-ON Electronics

Largest Supplier of Electrical and Electronic Components

Click to view similar products for [LED Lighting Drivers](#) category:

Click to view products by [Diodes Incorporated](#) manufacturer:

Other Similar products are found below :

[LV5235V-MPB-H](#) [MB39C602PNF-G-JNEFE1](#) [MIC2871YMK-T5](#) [AL1676-10BS7-13](#) [AL1676-20AS7-13](#) [AP5726WUG-7](#) [MX877RTR](#)
[ICL8201](#) [IS31BL3228B-UTLS2-TR](#) [IS31BL3506B-TTLS2-TR](#) [AL3157F-7](#) [AP5725FDCG-7](#) [AP5726FDCG-7](#) [LV52204MTTBG](#)
[SLG7NT4082VTR](#) [AP5725WUG-7](#) [STP4CMPQTR](#) [NCL30086BDR2G](#) [CAT4004BHU2-GT3](#) [LV52207AXA-VH](#) [AP1694AS-13](#)
[TLE4242EJ](#) [AS3688](#) [IS31LT3172-GRLS4-TR](#) [TLD2311EL](#) [KTD2694EDQ-TR](#) [KTZ8864EJAA-TR](#) [IS32LT3174-GRLA3-TR](#)
[ZXLD1374QESTTC](#) [AL1676-20BS7-13](#) [IS31FL3737B-QFLS4-TR](#) [IS31FL3239-QFLS4-TR](#) [KTD2058EUAC-TR](#) [KTD2037EWE-TR](#)
[DIO5662ST6](#) [IS31BL3508A-TTLS2-TR](#) [MAX20052CATC/V+](#) [MAX25606AUP/V+](#) [BD6586MUV-E2](#) [BD9206EFV-E2](#) [BD9416FS-E2](#)
[LYT4227E](#) [LYT6079C-TL](#) [MP3394SGF-P](#) [MP4689AGN-P](#) [MPQ4425AGQB-AEC1-Z](#) [TLD1311ELXUMA1](#) [TLE4309GATMA1](#)
[MIC2873YCS-TR](#) [TPS92410DR](#)