

Features

- PWM Buck Control Circuitry
- Operating voltage can be up to 27V
- Under voltage Lockout (UVLO) Protection
- Short Circuit Protection (SCP)
- Soft-start circuit
- Variable Oscillator Frequency -- 300Khz Max
- 1.25V voltage reference Output
- 8-pin SOP package
- SOP-8L: Available in "Green" Molding Compound (No Br, Sb)
- Lead Free Finish/ RoHS Compliant (Note 1)

General Description

The AP2004 integrates Pulse-Width-Modulation (PWM) control circuit into a single chip, mainly designs for power-supply regulator. All the functions include an on-chip 1.25V reference output, an error amplifier, an adjustable oscillator, a soft-start, UVLO, SCP circuitry, and a push-pull output circuit. Switching frequency is adjustable by trimming CT. During low VCC situation, the UVLO makes sure that the outputs are off until the internal circuit operates normally.

Applications

- Backlight inverter
- LCD Monitor
- CDROM, XDSL Product
- DC/DC converters in computers, etc.

Ordering Information

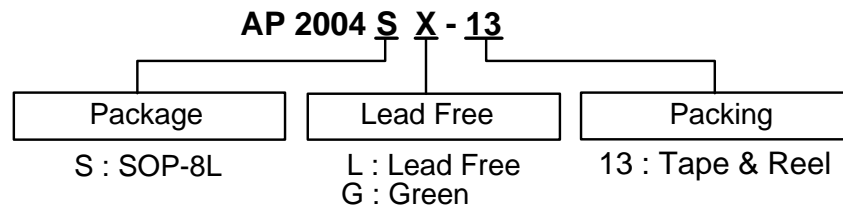

Device	Package Code	Packaging (Note 2)	13" Tape and Reel	
			Quantity	Part Number Suffix
AP2004SL-13	S	SOP-8L	2500/Tape & Reel	-13
AP2004SG-13	S	SOP-8L	2500/Tape & Reel	-13



- Notes:
1. EU Directive 2002/95/EC (RoHS). All applicable RoHS exemptions applied. Please visit our website at http://www.diodes.com/products/lead_free.html.
 2. Pad layout as shown on Diodes Inc. suggested pad layout document AP02001, which can be found on our website at <http://www.diodes.com/datasheets/ap02001.pdf>.

Pin Assignments

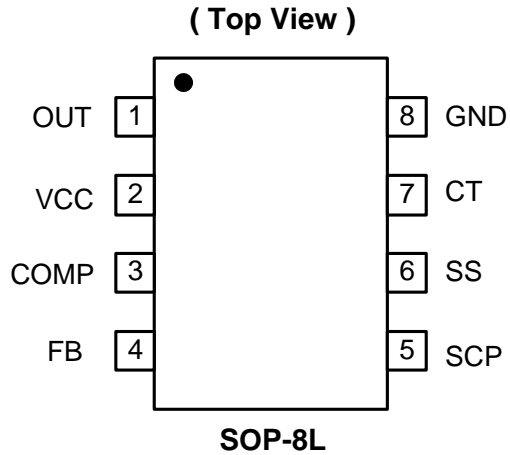

Pin Descriptions

Pin Name	Description
CT	Timing Capacitor
FB	Voltage Feedback
SS	Soft-Start.
COMP	Feedback Loop Compensation
OUT	PWM Output
GND	Ground
VCC	Supply Voltage
SCP	Short Circuit Protection

Block Diagram

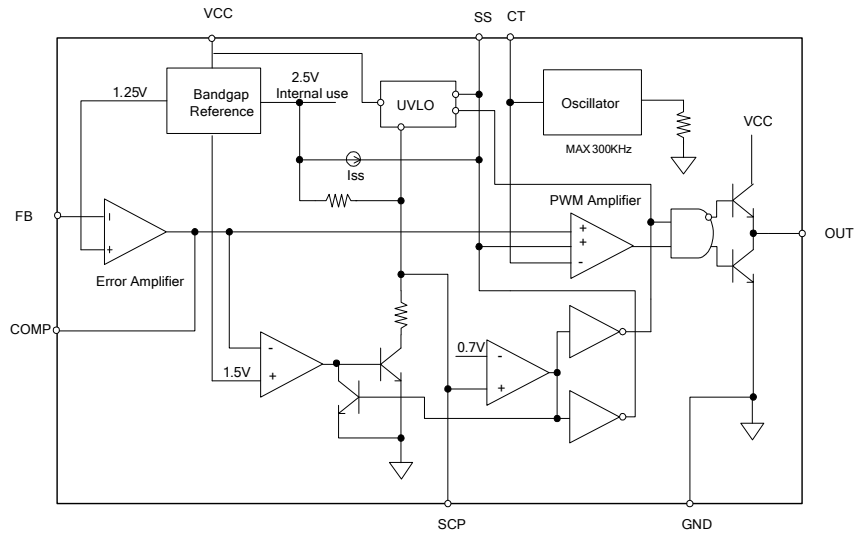

Absolute Maximum Ratings

Symbol	Parameter	Rating	Unit
P_D	Power dissipation at 25°C	600	mW
V_{CC}	Supply voltage	28	V
V_I	Amplifier input voltage	20	V
V_O	Collector output voltage	$V_{CC}-1.0V$	V
I_{SOURCE}	Source current	200	mA
I_{SINK}	Sink current	200	mA
T_{OP}	Operating junction temperature range	-20 to +125	°C
T_{ST}	Storage temperature range	-65 to +150	°C

Recommended Operating Conditions

Symbol	Parameter	Min	Max	Unit
V_{CC}	Supply voltage	3.6	27	V
V_I	Amplifier input voltage	1.05	1.45	V
V_O	Collector output voltage		$V_{CC}-1.5$	V
I_{FB}	Current into feedback terminal		45	μA
R_F	Feedback resistor	100		kΩ
C_T	Timing capacitor	100	6800	pF
F_{OSC}	Oscillator frequency	10	300	KHz

Electrical Characteristics ($T_A = 25^\circ\text{C}$, $V_{CC} = 6\text{V}$, $f = 200\text{KHz}$)

Reference (REF)

Symbol	Parameter	Conditions	Min	Typ.	Max	Unit
V_{REF}	Comp connect to FB		1.225	1.25	1.275	V
	Output voltage change with temperature	$T_A = -20^\circ\text{C} \sim 25^\circ\text{C}$		-0.1	± 1	%
		$T_A = 25^\circ\text{C} \sim 85^\circ\text{C}$			-0.2	± 1

Under voltage lockout (UVLO)

Symbol	Parameter	Conditions	Min	Typ.	Max	Unit
V_{UT}	Upper threshold voltage (V_{CC})	$I_{O(REF)} = 0.1\text{mA}$ $T_A = 25^\circ\text{C}$		2.9		V
V_{LWT}	Lower threshold voltage (V_{CC})				2.4	V
V_{HT}	Hysteresis (V_{CC})				500	mV

Short-circuit protection (SCP) control

Symbol	Parameter	Conditions	Min	Typ.	Max	Unit
V_{IT}	Input threshold voltage	$T_A = 25^\circ\text{C}$	0.60	0.67	0.75	V
V_{STB}	Standby voltage	No pull up	100	130	160	mV
V_{LT}	Latched input voltage	No pull up		50	100	mV
I_{SCP}	Input (source) current	$V_I = 0.7\text{V}$, $T_A = 25^\circ\text{C}$	-10	-15	-20	μA
V_{CT}	Comparator threshold voltage (COMP)			1.5		V

Oscillator (OSC)

Symbol	Parameter	Conditions	Min	Typ.	Max	Unit
F_{OSC}	Frequency	$C_T = 270\text{pF}$		200		KHz
ΔF_{OSC}	Standard deviation of frequency	$C_T = 270\text{pF}$		10		%
	Frequency change with voltage	$V_{CC} = 3.6\text{V} \sim 20\text{V}$		1		

Error-amplifier

Symbol	Parameter	Conditions	Min	Typ.	Max	Unit
V_{IO}	Input offset voltage	$V_O(\text{FB}) = 1.25\text{V}$			± 6	mV
I_{IO}	Input offset current	$V_O(\text{FB}) = 1.25\text{V}$			± 100	nA
I_{IB}	Input bias current	$V_O(\text{FB}) = 1.25\text{V}$		160	500	nA
V_{CM}	Common-mode input voltage range	$V_{CC} = 3.6\text{V} \sim 20\text{V}$	1.05		1.45	V
AV	Open-loop voltage amplification	$R_F = 200\text{k}\Omega$	70	80		dB
GBW	Unity-gain bandwidth			1.5		MHz
CMRR	Common-mode rejection ratio		60	80		dB
V_{OH}	Max. output voltage		$V_{ref}-0.1$			V
V_{OL}	Min. output voltage				1	V
I_{OI}	Output (sink) current (COMP)	$V_{ID} = -0.1\text{V}$, $V_O = 1.25\text{V}$	0.5	1.6		mA
I_{OO}	Output (source) current (COMP)	$V_{ID} = 0.1\text{V}$, $V_O = 1.25\text{V}$	-45	-70		μA

Electrical Characteristics (Continued) ($T_A = 25^\circ\text{C}$, $V_{CC} = 6\text{V}$, $f = 200\text{ KHz}$)

Output section

Symbol	Parameter	Conditions	Min	Typ.	Max	Unit
I_{LEAK}	Leakage current	$V_O = 25\text{V}$			10	μA
I_{DRV}	Sink current	$V_{IN} = 20\text{V}$		200		mA
	Source current	$V_{IN} = 20\text{V}$		200		mA
V_{SAT}	Output saturation voltage	$I_O = 10\text{ mA}$		1.0	1.5	V
I_{SC}	Short-circuit output current	$V_O = 6\text{V}$		120		mA

PWM comparator

Symbol	Parameter	Conditions	Min	Typ.	Max	Unit
V_{T0}	Input threshold voltage at $f = 10\text{ KHz}$ (COMP)	CT		0.6	0.7	V
V_{T100}		Maximum duty cycle	1.2	1.3		V

Total device

Symbol	Parameter	Conditions	Min	Typ.	Max	Unit
I_{CCA}	Average supply current	$C_T = 270\text{pF}$		6	10	mA

Soft Start

Symbol	Parameter	Conditions	Min	Typ.	Max	Unit
V_{SS}	Soft-start Voltage			2.3		V
I_{SS}	Constant Charge Current			20		μA

Typical Application Circuit

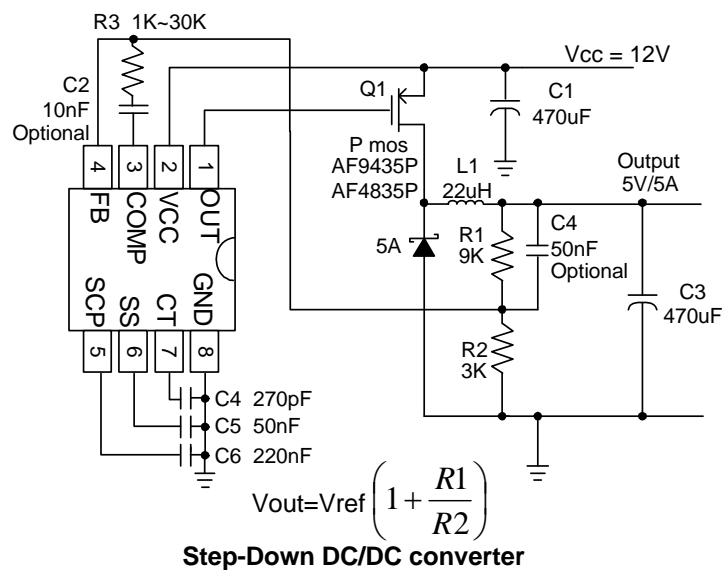

Typical Characteristics

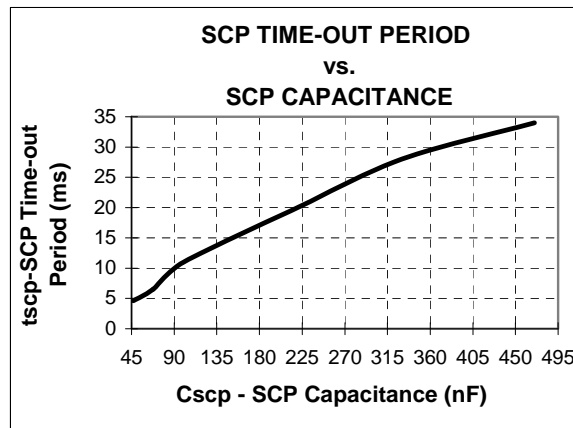
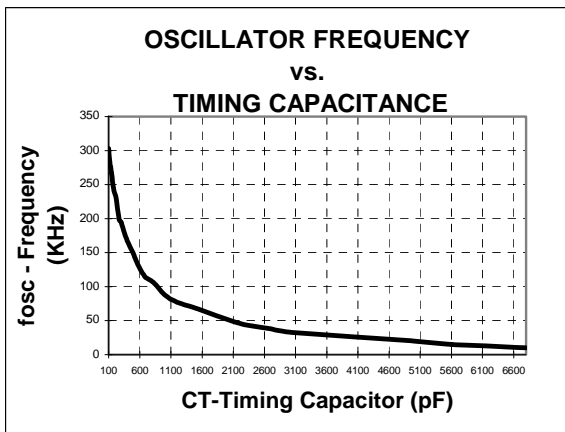
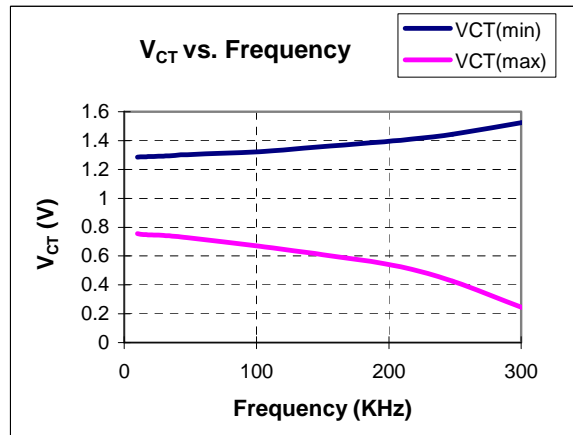
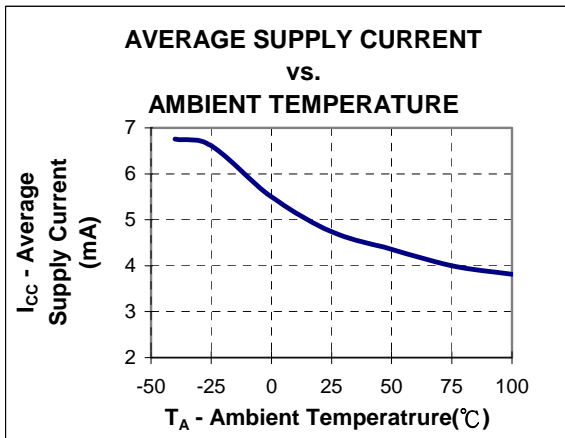
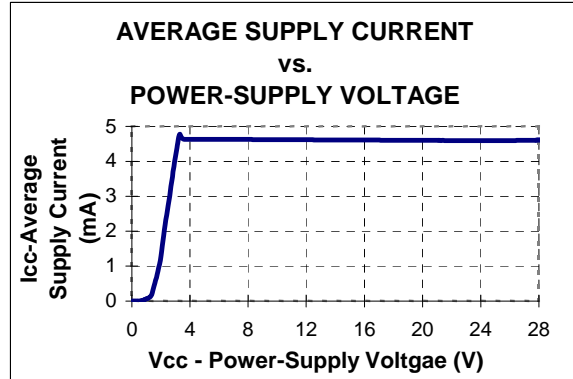
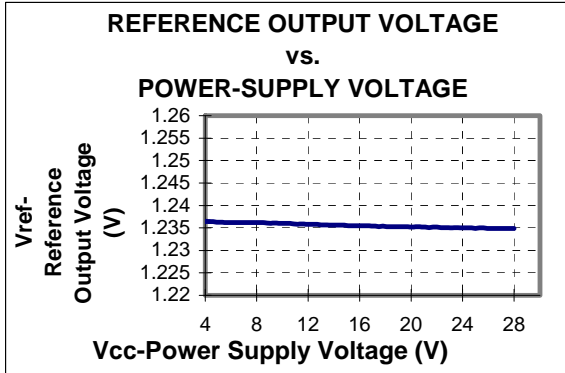

Typical Characteristics (Continued)

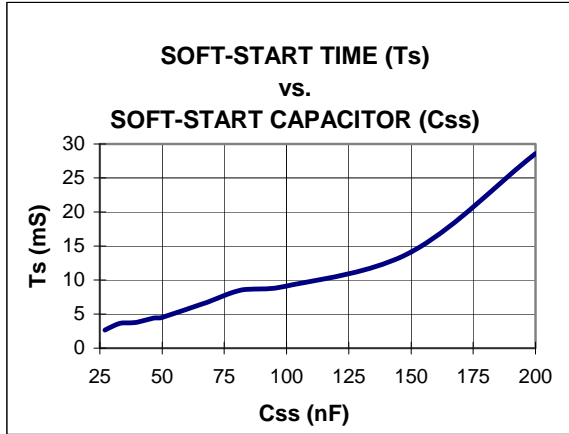

Marking Information

(1) SOP-8L

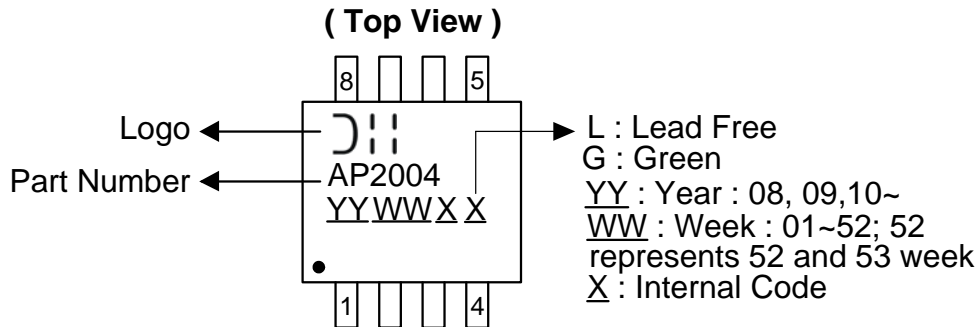

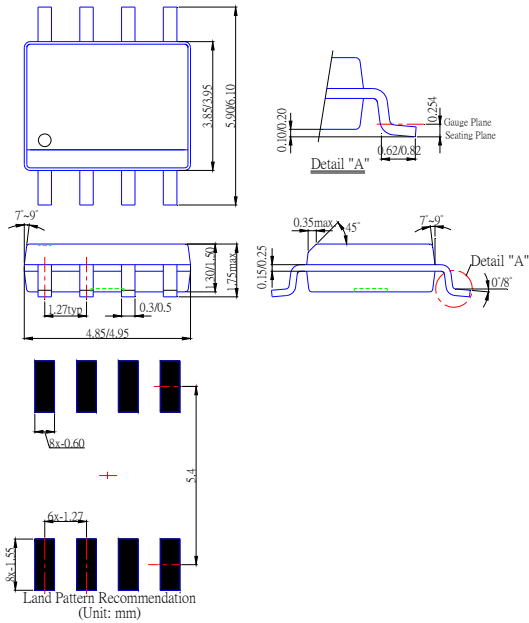
Package Information (All Dimensions in mm)**(1) Package Type: SOP- 8L****IMPORTANT NOTICE**

Diodes Incorporated and its subsidiaries reserve the right to make modifications, enhancements, improvements, corrections or other changes without further notice to any product herein. Diodes Incorporated does not assume any liability arising out of the application or use of any product described herein; neither does it convey any license under its patent rights, nor the rights of others. The user of products in such applications shall assume all risks of such use and will agree to hold Diodes Incorporated and all the companies whose products are represented on our website, harmless against all damages.

LIFE SUPPORT

Diodes Incorporated products are not authorized for use as critical components in life support devices or systems without the expressed written approval of the President of Diodes Incorporated.

X-ON Electronics

Largest Supplier of Electrical and Electronic Components

Click to view similar products for [Switching Controllers](#) category:

Click to view products by [Diodes Incorporated](#) manufacturer:

Other Similar products are found below :

[AZ7500EP-E1](#) [NCP1218AD65R2G](#) [NCP1234AD100R2G](#) [NCP1244BD065R2G](#) [NCP1336ADR2G](#) [NCP6153MNTWG](#) [NCP81205MNTXG](#)
[SJE6600](#) [SMBV1061LT1G](#) [SG3845DM](#) [NCP4204MNTXG](#) [NCP6132AMNR2G](#) [NCP81102MNTXG](#) [NCP81203MNTXG](#)
[NCP81206MNTXG](#) [NX2155HCUPTR](#) [UBA2051C](#) [MAX8778ETJ+](#) [NTBV30N20T4G](#) [NCP1240AD065R2G](#) [NCP1240FD065R2G](#)
[NCP1361BABAYSNT1G](#) [NTC6600NF](#) [TC105333ECTTR](#) [NCP1230P100G](#) [NCP1612BDR2G](#) [NX2124CSTR](#) [SG2845M](#)
[NCP81101MNTXG](#) [IFX81481ELV](#) [NCP81174NMNTXG](#) [NCP4308DMTTWG](#) [NCP4308DMNTWG](#) [NCP4308AMTTWG](#)
[NCP1251FSN65T1G](#) [NCP1246BLD065R2G](#) [LTC7852IUFD-1#PBF](#) [LTC7852EUFD-1#PBF](#) [MB39A136PFT-G-BND-ERE1](#)
[NCP1256BSN100T1G](#) [LV5768V-A-TLM-E](#) [NCP1365BABCYDR2G](#) [NCP1365AABCYDR2G](#) [MCP1633T-E/MG](#) [NCV1397ADR2G](#)
[AZ494AP-E1](#) [UTC3843D](#) [NCP4205MNTXG](#) [LM2576HVS-12](#) [RY3408](#)