

DESCRIPTION

The AP62500 is a 5A, synchronous buck converter with a wide input voltage range of 4.5V to 18V. The device fully integrates a 47mΩ high-side power MOSFET and a 18mΩ low-side power MOSFET to provide high-efficiency step-down DC-DC conversion.

The AP62500 device is easily used by minimizing the external component count due to its adoption of Constant On-Time (COT) control to achieve fast transient response, easy loop stabilization, and low output voltage ripple.

The AP62500 design is optimized for Electromagnetic Interference (EMI) reduction. The device has a proprietary gate driver scheme to resist switching node ringing without sacrificing MOSFET turn-on and turn-off times, which reduces high-frequency-radiated EMI noise caused by MOSFET switching.

The device is available in a V-QFN2030-12 (Type A) package.

FEATURES

- VIN: 4.5V to 18V
- Output Voltage (VOUT): 0.6V to 7V
- 5A Continuous Output Current
- 0.6V ± 1% Reference Voltage
- 195µA Quiescent Current
- Selectable Operation Modes
 - Pulse Frequency Modulation (PFM)
 - Ultrasonic Mode (USM)
 - Pulse Width Modulation (PWM)
- Selectable Switching Frequency
 - 400kHz
 - 800kHz
 - 1.2MHz
- Programmable Soft-Start Time
- Proprietary Gate Driver Design for Best EMI Reduction
- Power-Good Indicator
- Precision Enable Threshold to Adjust UVLO
- Protection Circuitry
 - Undervoltage Lockout (UVLO)
 - Cycle-by-Cycle Valley Current Limit
 - Thermal Shutdown

APPLICATIONS

- 5V and 12V Input Distributed Power Bus Supplies
- Television Sets and Monitors
- White Goods and Small Home Appliances
- FPGA, DSP, and ASIC Supplies
- Home Audio
- Network Systems
- Gaming Consoles
- Consumer Electronics
- General Purpose Point of Load

FUNCTIONAL BLOCK

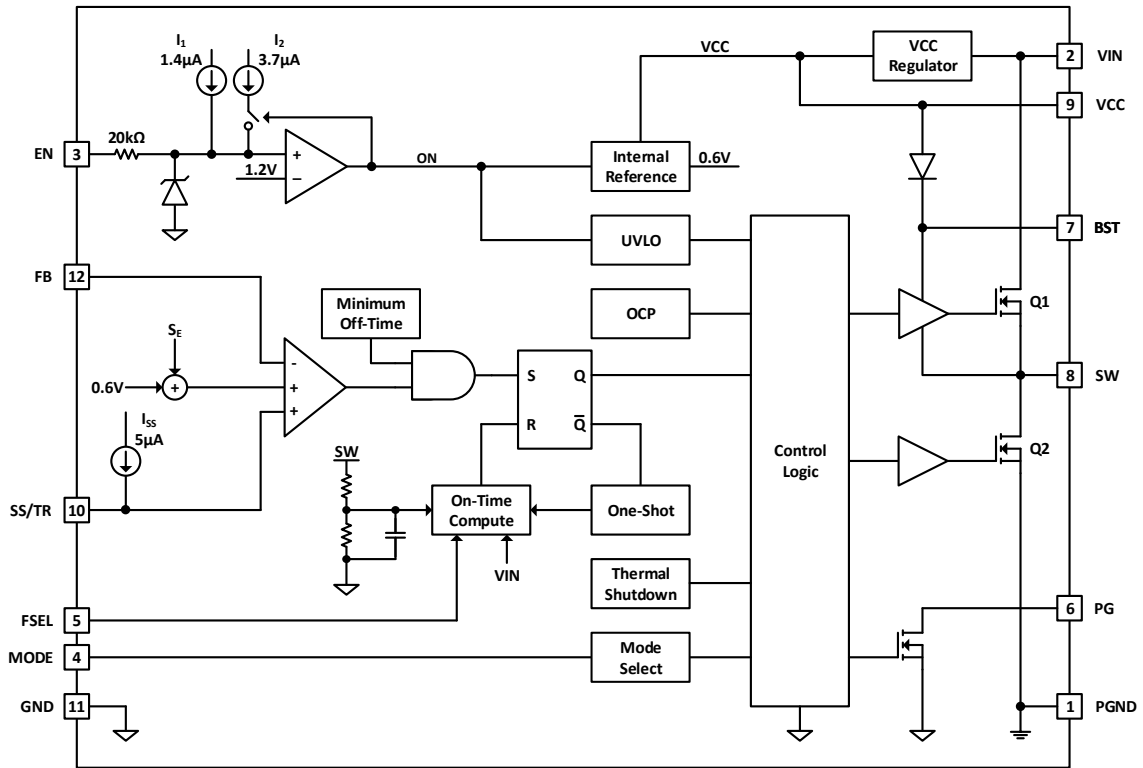

Figure 1. Functional Block Diagram

RECOMMENDED OPERATING CONDITIONS

Symbol	Parameter	Min	Max	Unit
VIN	Supply Voltage	4.5	18.0	V
VOUT	Output Voltage	0.6	7.0	V
T _A	Operating Ambient Temperature	-40	+85	°C
T _J	Operating Junction Temperature	-40	+125	°C

EVALUATION BOARD

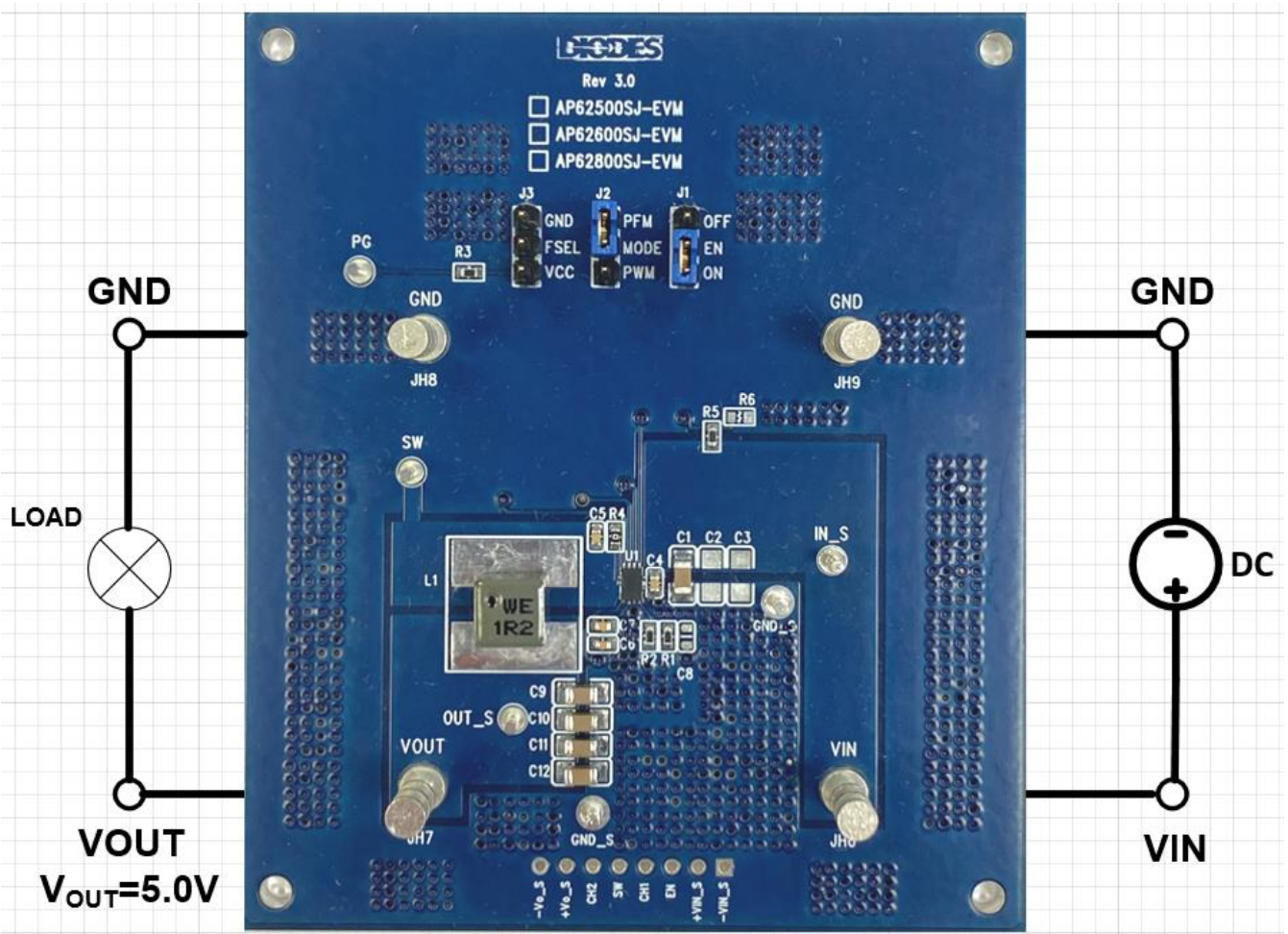

Figure 2. AP62500SJ-EVM

QUICK START GUIDE

The AP62500SJ-EVM has a simple layout and allows access to the appropriate signals through test points. The board is targeted to be used in providing a simple and convenient evaluation environment for the AP62500.

To operate the EVM, set jumpers J1, J2 and J3 to the desired positions per below shown.

- J1 = EN pin input jumper. For Enable, to enable IC, leave it OPEN or jump to “ON” to program an external resistor voltage divider at R5 and R6 to set the EN level. Jump to “OFF” position to disable IC.
- J2 = PFM, PWM or USM mode selection. At J2, connect a jumper to PWM to force the device in Pulse Width Modulation (PWM) operation mode. Connect a jumper to PFM to ground the pin to operate the device in Pulse Frequency Modulation (PFM) operation mode without Ultrasonic Mode (USM). Leave J2 OPEN to float the pin to operate the device in PFM with USM mode.
- J3 = Switching frequency selection. At J3, connect a jumper to GND to set clock frequency to 400kHz. Leave J3 OPEN to float the pin to set clock frequency to 800kHz. Connect a jumper to VCC to set clock frequency to 1.2MHz.

To evaluate the performance of the AP62500SJ-EVM, follow the procedure below:

1. Connect a power supply to the input terminals VIN and GND. Set VIN to 12V.
2. Connect the positive terminal of the electronic load to VOUT and negative terminal to GND.
3. By default, the evaluation board should now power up with a 5.0V output voltage. Frequency is 800kHz.
4. Check for the proper output voltage of 5.0V ($\pm 1\%$) at the output terminals VOUT and GND. Measurement can also be done with a multimeter with the positive and negative leads between VOUT and GND.
5. Set the load to 5A through the electronic load. Check for the stable operation of the SW signal on the oscilloscope. Measure the switching frequency.

MEASUREMENT/PERFORMANCE GUIDELINES:

- 1) When measuring the output voltage ripple, maintain the shortest possible ground lengths on the oscilloscope probe. Long ground leads can erroneously inject high frequency noise into the measured ripple.
- 2) For efficiency measurements, connect an ammeter in series with the input supply to measure the input current. Connect an electronic load to the output for output current.

APPLICATION INFORMATION

Setting the Output Voltage of AP62500

(1) Setting the output voltage:

The AP62500 features external programmable output voltage by using a resistor divider network R2 and R1 as shown in the typical application circuit. The output voltage is calculated as below;

$$R1 = R2 \cdot \left(\frac{V_{OUT}}{0.6V} - 1 \right)$$

First, select a value for R1 according to the value recommended in table 1. Then, R3 is determined. The output voltage is given by Table 1 for reference. For accurate output voltage, 1% tolerance is required.

Table 1. Resistor selection for output voltage setting

V _o	R2	R1
1.2V	10kΩ	10kΩ
1.5V	10kΩ	15kΩ
1.8V	10kΩ	20kΩ
2.5V	10kΩ	31.6kΩ
3.3V	10kΩ	45.3kΩ
5V	10kΩ	73.2kΩ

EXTERNAL COMPONENT SELECTION:

Table 2. Recommended inductors and output capacitor AP62500

Output Voltage (V)	Frequency (kHz)	R1 (kΩ)	R2 (kΩ)	L1 (μH)	C1 (μF)	C9, C10, C11 (μF)	C5 (nF)
1.2	400	10	10	1.50	22	3 x 22	100
	800			0.75			
	1200			0.51			
1.5	400	15	10	1.80	22	3 x 22	100
	800			0.87			
	1200			0.62			
1.8	400	20	10	2.00	22	3 x 22	100
	800			1.00			
	1200			0.68			
2.5	400	31.6	10	2.70	22	3 x 22	100
	800			1.30			
	1200			0.87			
3.3	400	45.3	10	3.3	22	3 x 22	100
	800			1.5			
	1200			1.00			
5.0	400	73.2	10	3.5	22	3 x 22	100
	800			2.2			
	1200			1.20			

EVALUATION BOARD SCHEMATIC

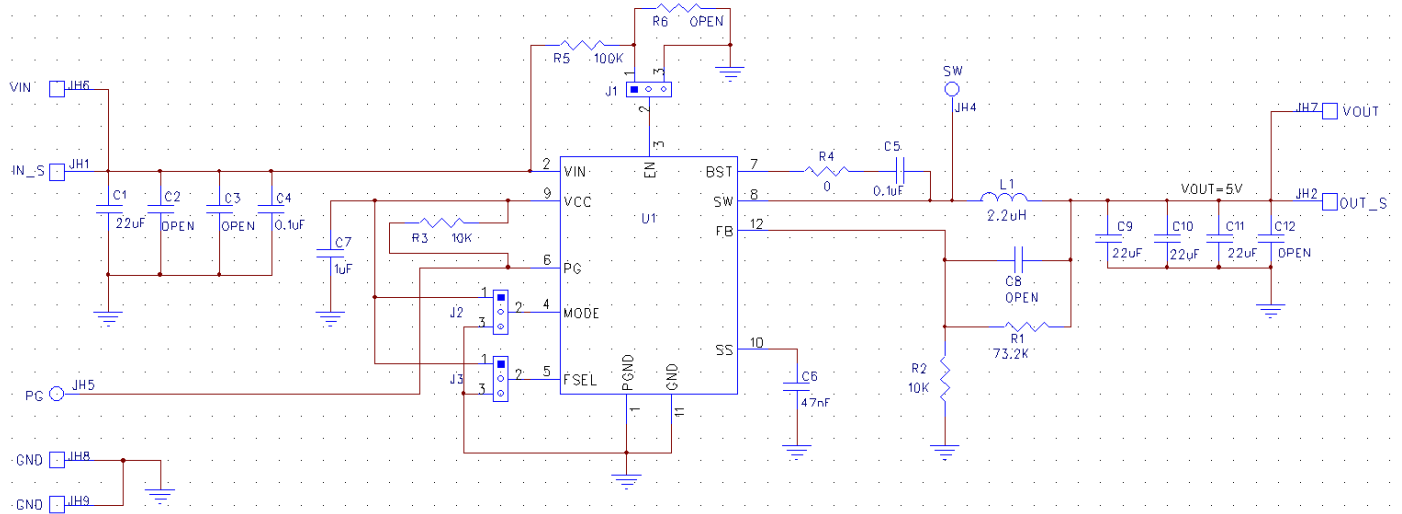

Figure 3. AP62500SJ-EVM Schematic

PCB TOP LAYOUT

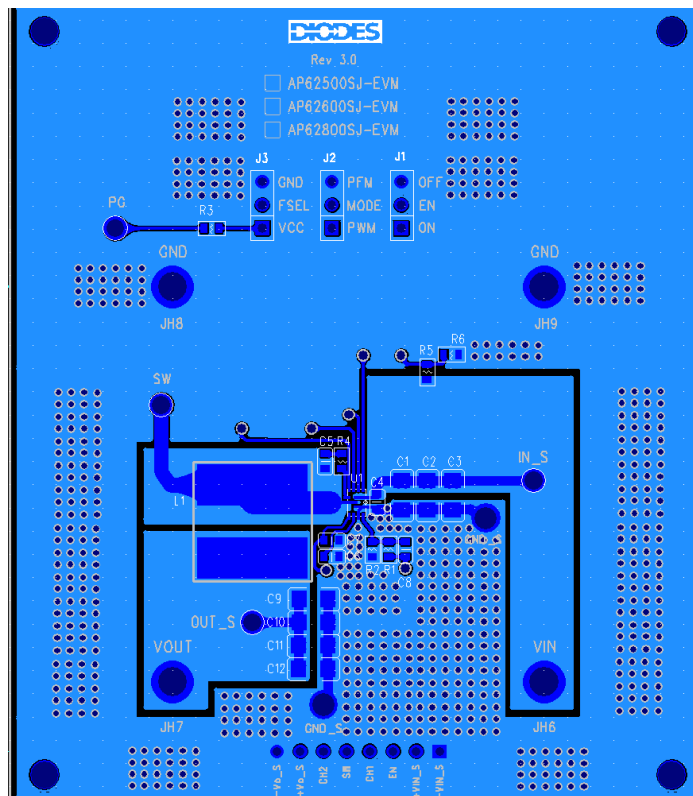

Figure 4. AP62500SJ-EVM – Top Layer

PCB INNER LAYER 2 LAYOUT

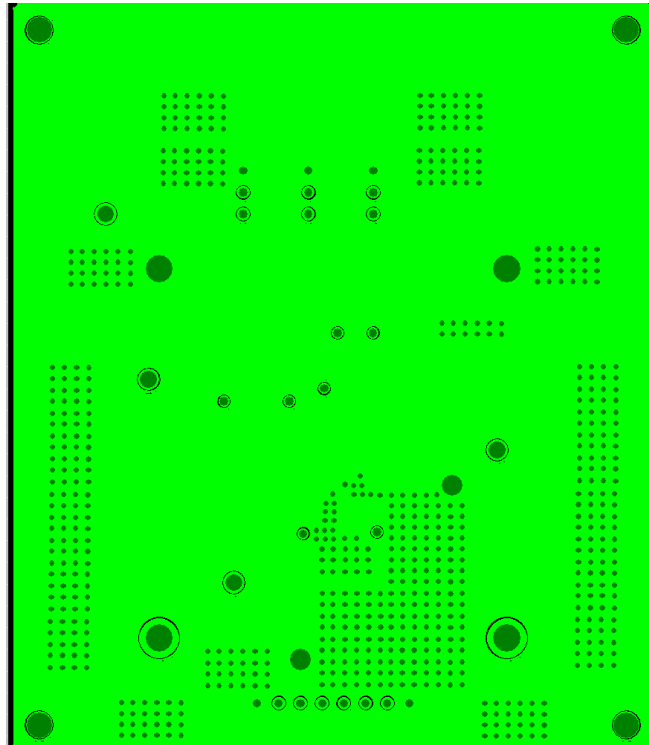

Figure 5. AP62500SJ-EVM – Inner Layer 2

PCB INNER LAYER 3 LAYOUT

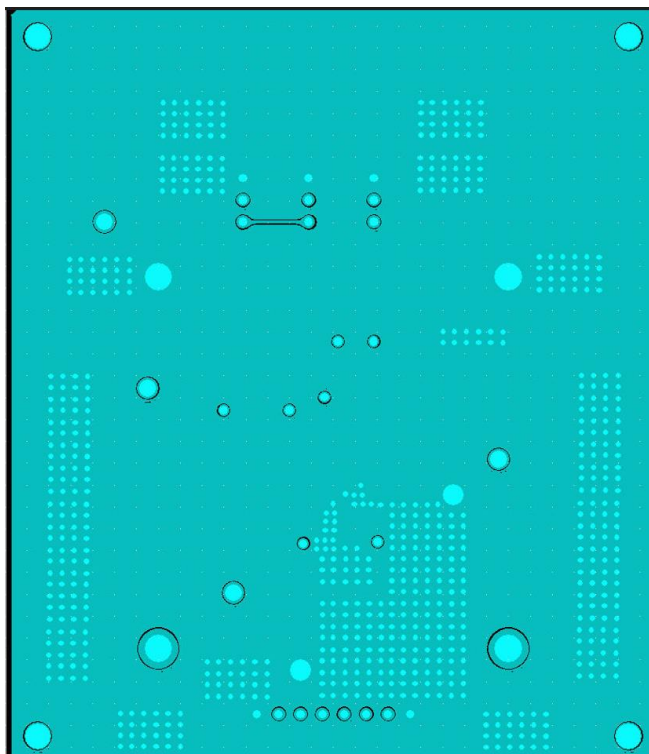

Figure 6. AP62500SJ-EVM – Inner Layer 3

PCB BOTTOM LAYOUT

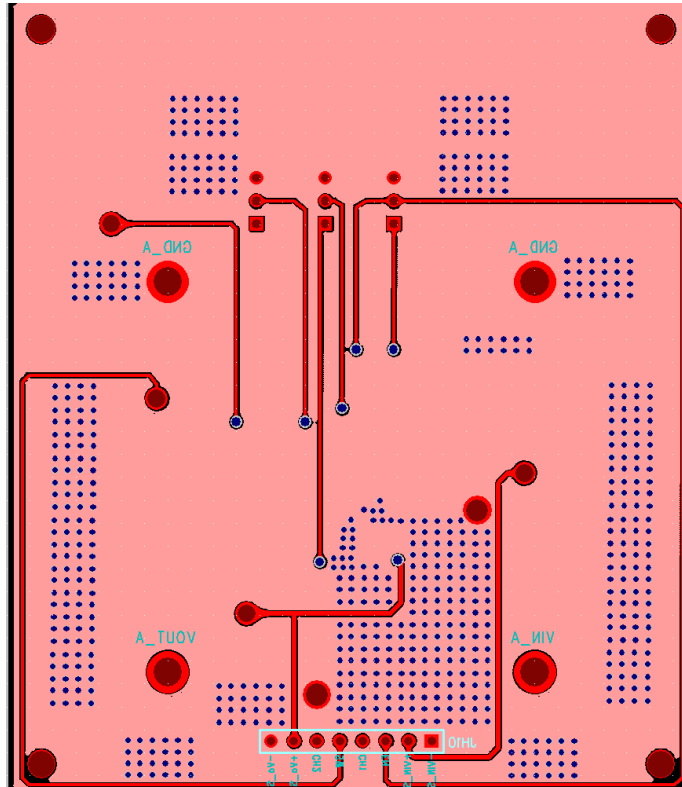

Figure 7. AP62500SJ-EVM – Bottom Layer

BILL OF MATERIALS for AP62500SJ-EVM for $V_{OUT}=5V$ @800kHz

Ref	Value	Description	Qty	Size	Vendor	Manufacturer PN	PCB Layer
C1, C9, C10, C11	22 μ F	Ceramic Capacitor, 25V, X6S	4	1206	Samsung	CL31X226KAHN3NE	Top
C4, C5	0.1 μ F	Ceramic Capacitor, 50V, X7R, 10%	2	0603	Wurth Electronics	885012206095	Top
C6	47nF	Ceramic Capacitor, 50V, X7R, 10%	1	0603	Wurth Electronics	885012206093	Top
C7	1 μ F	Ceramic Capacitor, 25V, X7R, 10%	1	0603	Wurth Electronics	885012206076	Top
L1	2.2 μ H	DCR=10.5m Ω , Ir=8A	1	6.65x6.45x3.30mm	Wurth Electronics	74439344022	Top
R1	73.2K Ω	RES SMD 1%	1	0603	Panasonic	ERJ-3EKF7322V	Top
R2, R3	10K Ω	RES SMD 1%	2	0603	Panasonic	ERJ-3EKF1002V	Top
R4	0 Ω	RES SMD 1%	1	0603	Yageo	RC0603FR-070RL	Top

R5	100KΩ	RES SMD 1%	1	0603	Yageo	AC0603FR-13100KL	Top
J1, J2, J3		PCB Header, 40 POS	3	1X3	3M	2340-6111TG	Top
JH6, JH7, JH8, JH9	1598	Terminal Turret Triple 0.094" L (Test Points)	4	Through-Hole	Keystone Electronics	1598-2	Top
U1	AP62500	5A Sync DC/DC Converter	1	QFN2030-12	Diodes Incorporated (Diodes)	AP62500SJ	Top

TYPICAL PERFORMANCE CHARACTERISTICS

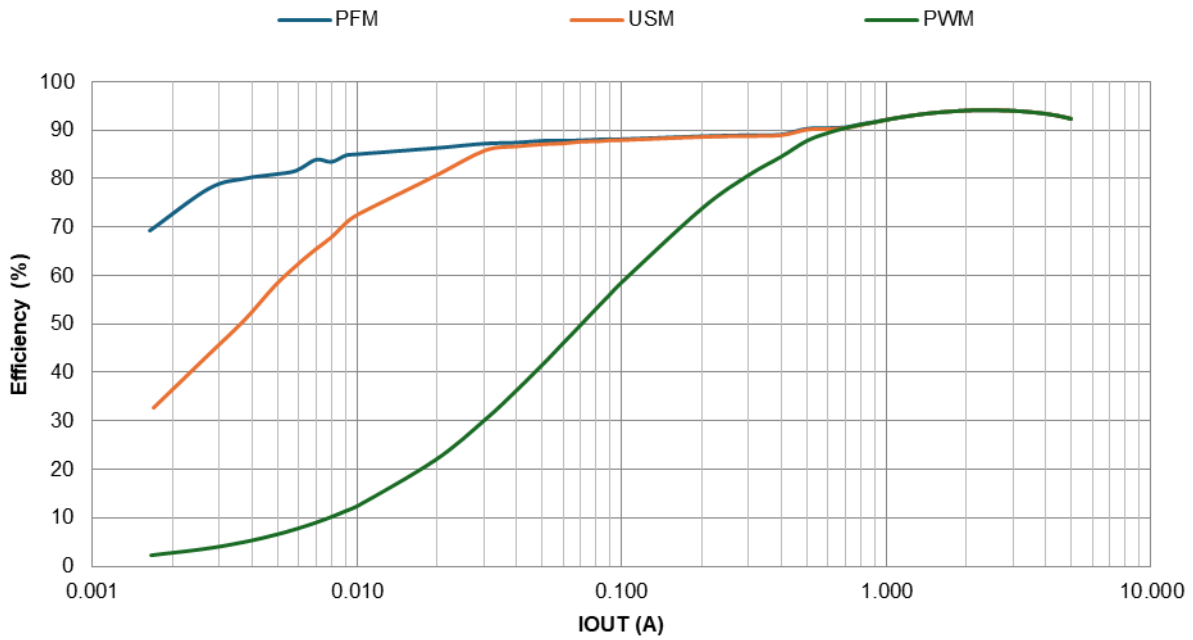

Figure 8. Efficiency vs. Output Current, VIN = 12V, VOUT = 5V, L = 2.2µH, fsw = 800kHz

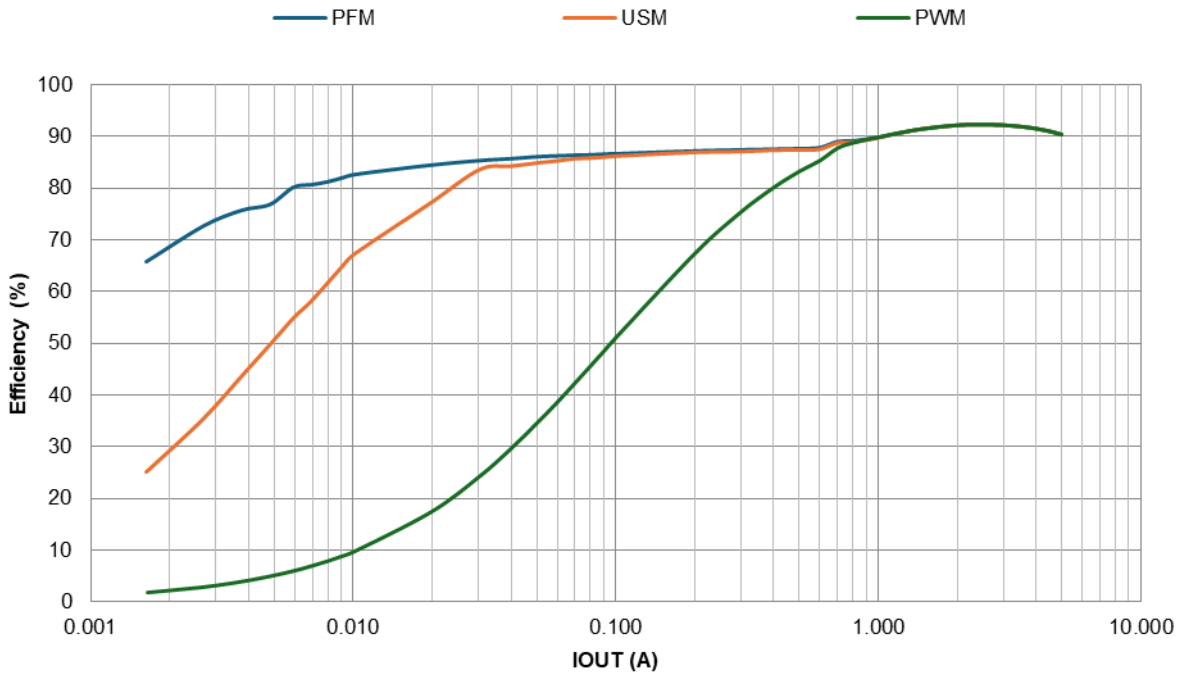
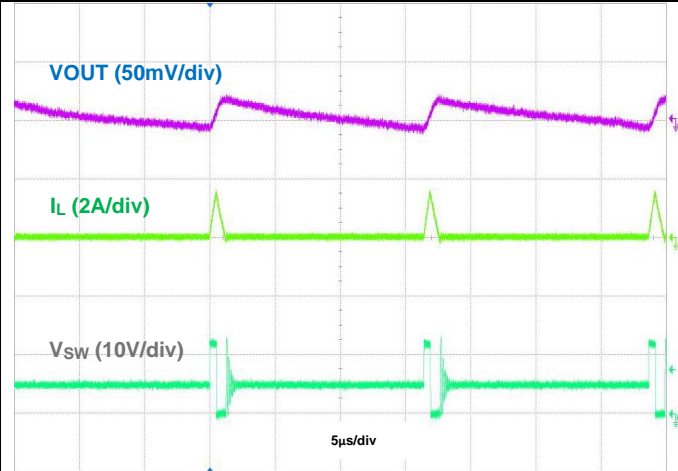
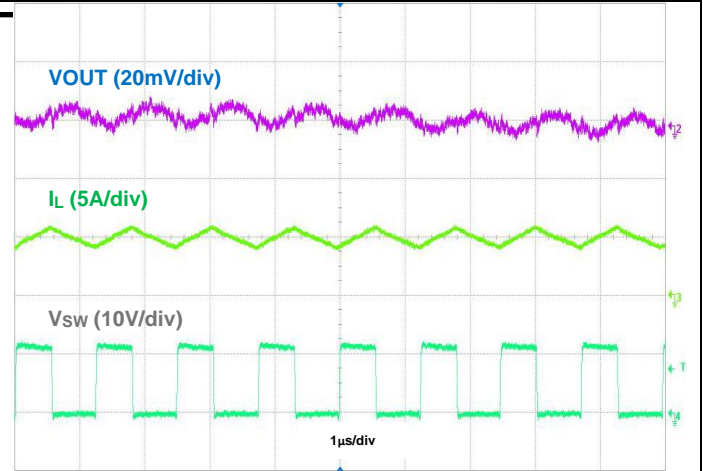

Figure 9. Efficiency vs. Output Current, VIN = 12V, VOUT = 3.3V, L = 1.5µH, fsw = 800kHz



**Figure 10. Output Voltage Ripple, IOUT = 50mA
VIN = 12V, VOUT = 5V PFM fsw = 800kHz**



**Figure 11. Output Voltage Ripple, IOUT = 5A
VIN = 12V, VOUT = 5V PFM fsw = 800kHz**

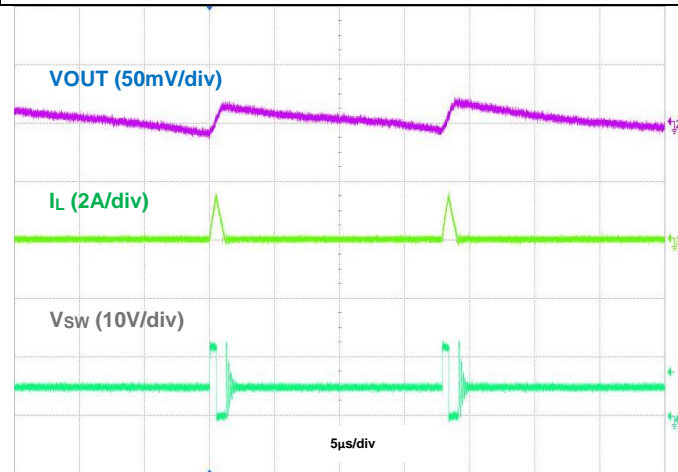

**Figure 12. Output Voltage Ripple, IOUT = 50mA
VIN = 12V, VOUT = 5V USM fsw = 800kHz**

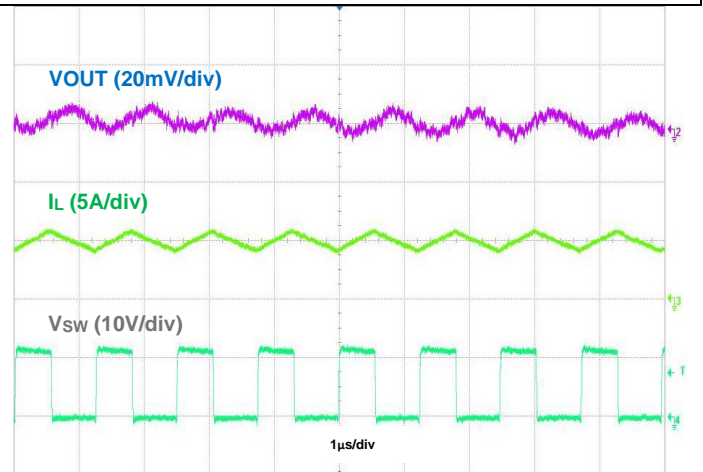

**Figure 13. Output Voltage Ripple, IOUT = 5A
VIN = 12V, VOUT = 5V USM fsw = 800kHz**

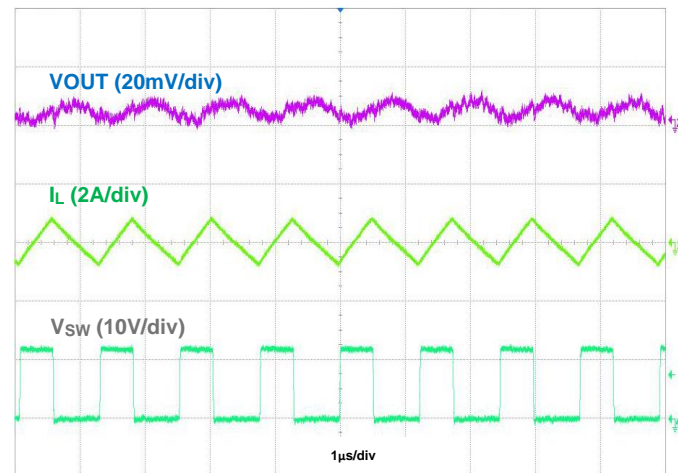

**Figure 14. Output Voltage Ripple, IOUT = 50mA
VIN = 12V, VOUT = 5V PWM fsw = 800kHz**

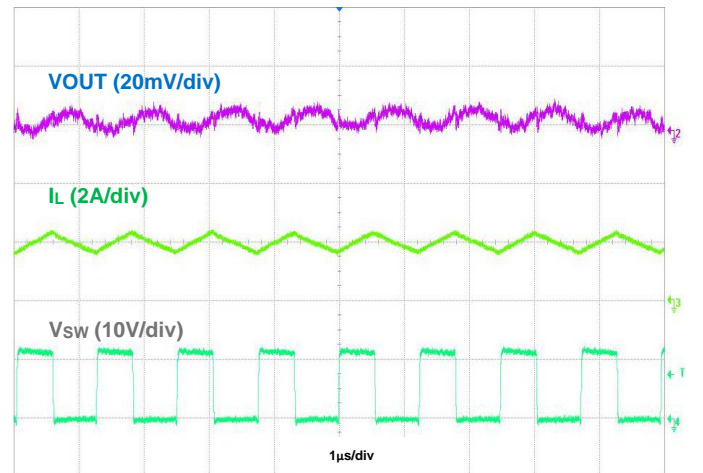

**Figure 15. Output Voltage Ripple, IOUT = 5A
VIN = 12V, VOUT = 5V PWM fsw = 800kHz**

IMPORTANT NOTICE

1. DIODES INCORPORATED (Diodes) AND ITS SUBSIDIARIES MAKE NO WARRANTY OF ANY KIND, EXPRESS OR IMPLIED, WITH REGARDS TO ANY INFORMATION CONTAINED IN THIS DOCUMENT, INCLUDING, BUT NOT LIMITED TO, THE IMPLIED WARRANTIES OF MERCHANTABILITY, FITNESS FOR A PARTICULAR PURPOSE OR NON-INFRINGEMENT OF THIRD PARTY INTELLECTUAL PROPERTY RIGHTS (AND THEIR EQUIVALENTS UNDER THE LAWS OF ANY JURISDICTION).
2. The Information contained herein is for informational purpose only and is provided only to illustrate the operation of Diodes' products described herein and application examples. Diodes does not assume any liability arising out of the application or use of this document or any product described herein. This document is intended for skilled and technically trained engineering customers and users who design with Diodes' products. Diodes' products may be used to facilitate safety-related applications; however, in all instances customers and users are responsible for (a) selecting the appropriate Diodes products for their applications, (b) evaluating the suitability of Diodes' products for their intended applications, (c) ensuring their applications, which incorporate Diodes' products, comply the applicable legal and regulatory requirements as well as safety and functional-safety related standards, and (d) ensuring they design with appropriate safeguards (including testing, validation, quality control techniques, redundancy, malfunction prevention, and appropriate treatment for aging degradation) to minimize the risks associated with their applications.
3. Diodes assumes no liability for any application-related information, support, assistance or feedback that may be provided by Diodes from time to time. Any customer or user of this document or products described herein will assume all risks and liabilities associated with such use, and will hold Diodes and all companies whose products are represented herein or on Diodes' websites, harmless against all damages and liabilities.
4. Products described herein may be covered by one or more United States, international or foreign patents and pending patent applications. Product names and markings noted herein may also be covered by one or more United States, international or foreign trademarks and trademark applications. Diodes does not convey any license under any of its intellectual property rights or the rights of any third parties (including third parties whose products and services may be described in this document or on Diodes' website) under this document.
5. Diodes' products are provided subject to Diodes' Standard Terms and Conditions of Sale (<https://www.diodes.com/about/company/terms-and-conditions/terms-and-conditions-of-sales/>) or other applicable terms. This document does not alter or expand the applicable warranties provided by Diodes. Diodes does not warrant or accept any liability whatsoever in respect of any products purchased through unauthorized sales channel.
6. Diodes' products and technology may not be used for or incorporated into any products or systems whose manufacture, use or sale is prohibited under any applicable laws and regulations. Should customers or users use Diodes' products in contravention of any applicable laws or regulations, or for any unintended or unauthorized application, customers and users will (a) be solely responsible for any damages, losses or penalties arising in connection therewith or as a result thereof, and (b) indemnify and hold Diodes and its representatives and agents harmless against any and all claims, damages, expenses, and attorney fees arising out of, directly or indirectly, any claim relating to any noncompliance with the applicable laws and regulations, as well as any unintended or unauthorized application.
7. While efforts have been made to ensure the information contained in this document is accurate, complete and current, it may contain technical inaccuracies, omissions and typographical errors. Diodes does not warrant that information contained in this document is error-free and Diodes is under no obligation to update or otherwise correct this information. Notwithstanding the foregoing, Diodes reserves the right to make modifications, enhancements, improvements, corrections or other changes without further notice to this document and any product described herein. This document is written in English but may be translated into multiple languages for reference. Only the English version of this document is the final and determinative format released by Diodes.
8. Any unauthorized copying, modification, distribution, transmission, display or other use of this document (or any portion hereof) is prohibited. Diodes assumes no responsibility for any losses incurred by the customers or users or any third parties arising from any such unauthorized use.
9. This Notice may be periodically updated with the most recent version available at <https://www.diodes.com/about/company/terms-and-conditions/important-notice>

The Diodes logo is a registered trademark of Diodes Incorporated in the United States and other countries.
All other trademarks are the property of their respective owners.
© 2024 Diodes Incorporated. All Rights Reserved.

www.diodes.com

X-ON Electronics

Largest Supplier of Electrical and Electronic Components

Click to view similar products for [Power Management IC Development Tools](#) *category:*

Click to view products by [Diodes Incorporated](#) *manufacturer:*

Other Similar products are found below :

[EVB-EP5348UI](#) [BQ25010EVM](#) [ISL80019AEVAL1Z](#) [ISLUSBI2CKIT1Z](#) [ISL8002AEVAL1Z](#) [ISL91108IIA-EVZ](#) [ISL28022EVKIT1Z](#)
[STEVAL-ISA008V1](#) [DRI0043](#) [NCP10671B05GEVB](#) [EVB-EN6337QA](#) [SAMPLEBOXILD8150TOBO1](#) [AP61100Z6-EVM](#) [AP62300WU-](#)
[EVM](#) [KITA2GTC387MOTORCTRTOBO1](#) [AEK-MOT-TK200G1](#) [EVLONE65W](#) [STEVAL-ILH006V1](#) [STEVAL-IPE008V2](#) [STEVAL-](#)
[IPP001V2](#) [STEVAL-ISA013V1](#) [STEVAL-ISA067V1](#) [STEVAL-ISQ002V1](#) [TPS2306EVM-001](#) [TPS2330EVM-185](#) [TPS40001EVM-001](#)
[SECO-HVDCDC1362-15W-GEVB](#) [BTS7030-2EPA](#) [LTC3308AIV#WTRPBF](#) [TLT807B0EPV](#) [BTS71033-6ESA](#) [EV13N91A](#) [EV55W64A](#)
[Si8285_86v2-KIT](#) [NCP-NCV51752D2PAK3LGEVB](#) [ISL81807EVAL1Z](#) [EVALM7HVIGBTPFCINV4TOBO1](#) [903-0300-000](#) [903-0301-000](#)
[ROA1286023/1](#) [REFSHA35IMD111TSYSTOBO1](#) [150037482](#) [SABMB629](#) [TDINV3000W50B-KIT](#) [NCP1681CCM1KWGEVB](#) [I7C08A-](#)
[CC3-EVK-P2](#) [I7C12A-CC3-EVK-P2](#) [i7C20A-CC3-EVK-P2](#) [RTK9754L27S01000BE](#) [APEK89303KET-01-T](#)