

DESCRIPTION

The AP63205Q is a 2A, synchronous buck converter with a wide input voltage range of 3.8V to 32V. It fully integrates a 125mΩ high-side power MOSFET and a 68mΩ low-side power MOSFET to provide high-efficiency step-down DC-DC conversion.

The AP63205Q device is easily used by minimizing the external component count due to its adoption of peak current mode control along with its integrated compensation network.

The AP63205Q is a fixed output buck converter with Electromagnetic Interference (EMI) reduction. The converter features Frequency Spread Spectrum (FSS) with a

switching frequency jitter of $\pm 6\%$, reducing EMI by not allowing emitted energy to stay in any one frequency for a significant period of time. It also has a proprietary gate driver scheme to resist switching node ringing without sacrificing MOSFET turn-on and turn-off times, which further reduces high-frequency radiated EMI noise caused by MOSFET switching.

The device is available in a low-profile, TSOT26 package.

FEATURES

- VIN 3.8V to 32V
- 2A Continuous Output Current
- 0.8V $\pm 1\%$ Reference Voltage
- 22 μ A Low Quiescent Current (Pulse Frequency Modulation)
- 1.1MHz Switching Frequency
- Supports Pulse Frequency Modulation (PFM) and Pulse Width Modulation (PWM)
- Proprietary Gate Driver Design for Efficient EMI Reduction
- Frequency Spread Spectrum (FSS) to Reduce EMI
- Low-Dropout (LDO) Mode
- Precision Enable Threshold to Adjust UVLO
- Protection Circuitry
 - Undervoltage Lockout (UVLO)
 - Cycle-by-Cycle Peak Current Limit
 - Thermal Shutdown

FUNCTIONAL BLOCK

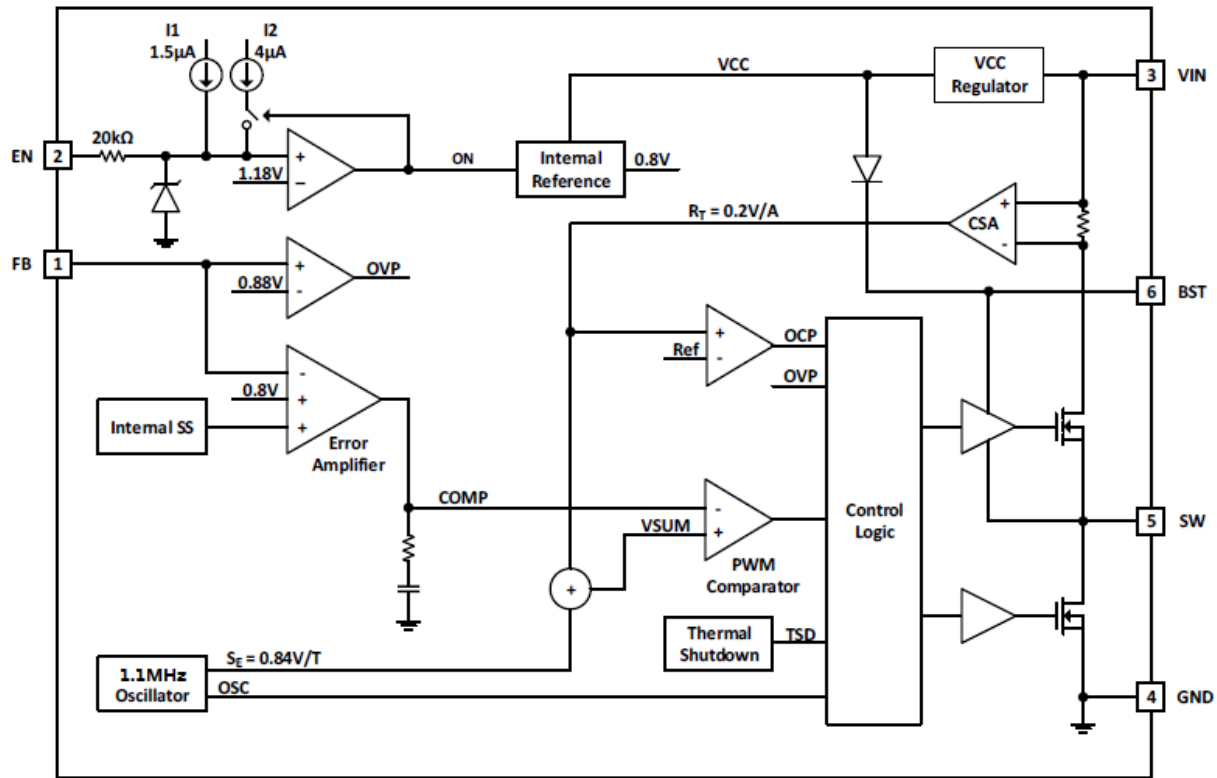

Figure 1. Functional Block Diagram

ABSOLUTE MAXIMUM RATINGS

Symbol	Parameter	Rating	Unit
VIN	Supply Voltage	-0.3 to +35.0 (DC)	V
		-0.3 to +40.0 (400ms)	
V _{SW}	Switch Node Voltage	-1.0 to VIN + 0.3 (DC)	V
		-2.5 to VIN + 2.0 (20ns)	
V _{BST}	Bootstrap Voltage	V _{SW} - 0.3 to V _{SW} + 6.0	V
V _{FB}	Feedback Voltage	-0.3 to +6.0	V
V _{EN}	Enable/UVLO Voltage	-0.3 to +35.0	V
T _{ST}	Storage Temperature	-65 to +150	°C
T _J	Junction Temperature	+150	°C
T _L	Lead Temperature	+260	°C

ESD Susceptibility			
HBM	Human Body Mode	2000	V
CDM	Charge Device Model	1000	V

RECOMMENDED OPERATING CONDITIONS

Symbol	Parameter	Min	Max	Unit
VIN	Supply Voltage	3.8	32	V
T _A	Operating Ambient Temperature Range	-40	+125	°C
T _J	Operating Junction Temperature Range	-40	+150	°C

EVALUATION BOARD

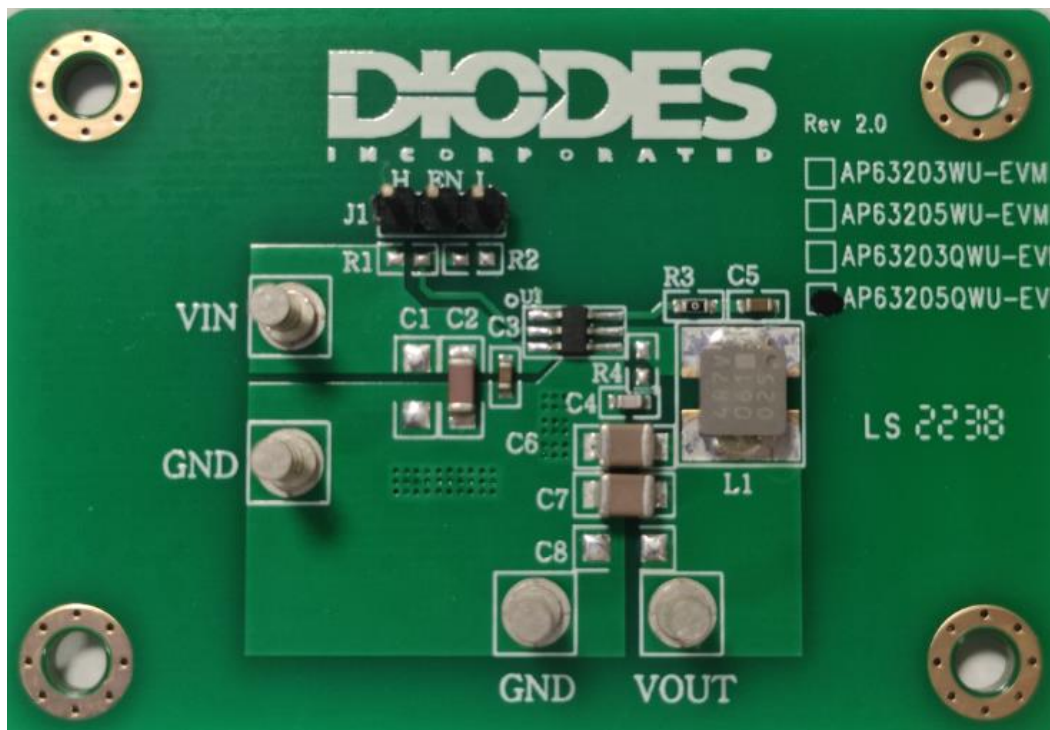

Figure 2. AP63205QWU-EVM

QUICK START GUIDE

The AP63205QWU-EVM has a simple layout and allows access to the appropriate signals through test points. To evaluate the performance of the AP63205QWU, follow the procedure below:

1. For evaluation board configured at $V_{OUT}=5V$, connect a power supply to the input terminals V_{IN} and GND. Set V_{IN} to 12V.
2. Connect the positive terminal of the electronic load to V_{OUT} and negative terminal to GND.
3. For Enable, place a jumper to “H” position to enable IC. Jump to “L” position to disable IC.
4. The evaluation board should now power up with a 5V output voltage.
5. Check for the proper output voltage of 5V ($\pm 1\%$) at the output terminals V_{OUT} and GND. Measurement can also be done with a multimeter with the positive and negative leads between V_{OUT} and GND.
6. Set the load to 2A through the electronic load. Check for the stable operation of the SW signal on the oscilloscope. Measure the switching frequency.

MEASUREMENT/PERFORMANCE GUIDELINES:

- 1) When measuring the output voltage ripple, maintain the shortest possible ground lengths on the oscilloscope probe. Long ground leads can erroneously inject high frequency noise into the measured ripple.
- 2) For efficiency measurements, connect an ammeter in series with the input supply to measure the input current. Connect an electronic load to the output for output current.

SETTING OUTPUT VOLTAGE:

Setting the output voltage:

The AP63205Q is a fixed output buck converter. The output voltage is 5V. Connect VFB pin to output directly as schematic shown.

EVALUATION BOARD SCHEMATIC

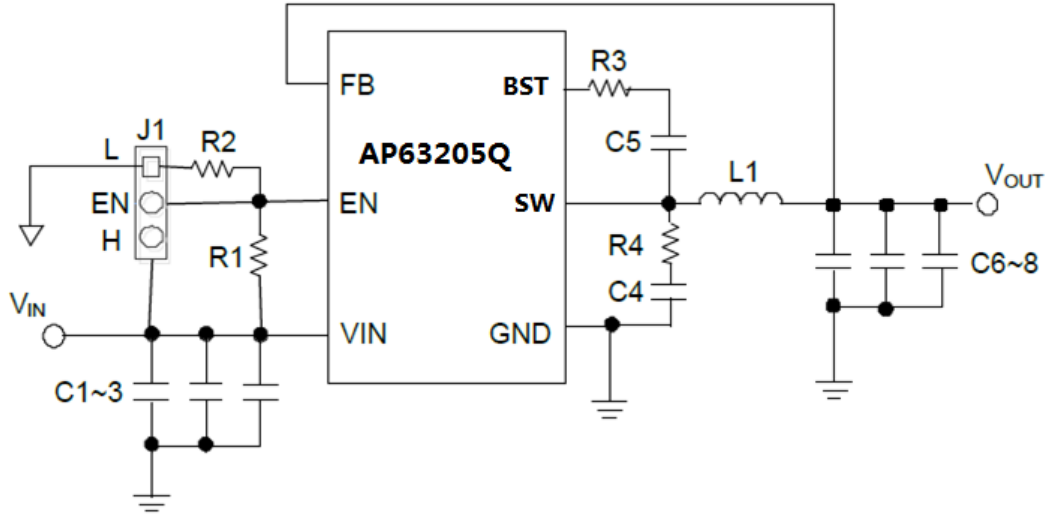

Figure 3. AP63205QWU-EVM Schematic

BILL OF MATERIALS for AP63205QWU-EVM (V_{OUT}=5V)

Item	Value	Type	Rating	Description	Description
C1				Input CAP	open
C2	10Uf	X7R, Ceramic/1206	50V	Input CAP	CGA5L1X7R1H106K160AC
C3	0.1Uf	Ceramic/0603	50V	Input CAP	GCM188L81H104KA57
C4	100pF	Ceramic/0603	100V	Feedback CAP	GCM1885G2A101JA16
C5	0.1Uf	Ceramic/0603	50V	Bootstrap CAP	GCM188L81H104KA57
C6	22Uf	X8L, Ceramic/1206	16V	Output CAP	CGA6P1X8L1C226M250AC
C7	22Uf	X8L, Ceramic/1206	16V	Output CAP	CGA6P1X8L1C226M250AC
C8				Output CAP	open
L1	4.7µH			Inductor	Panasonic ETQP3M4R7KVP
R1					open
R2					open
R3	0	0603	1%	Bootstrap RES	ERJ-3GEY0R00V
R4					open
H EN L				Würth Electronics	61304011121
U1		AP63205QWU		TSOT23-6	Diodes BCD

TYPICAL PERFORMANCE CHARACTERISTICS

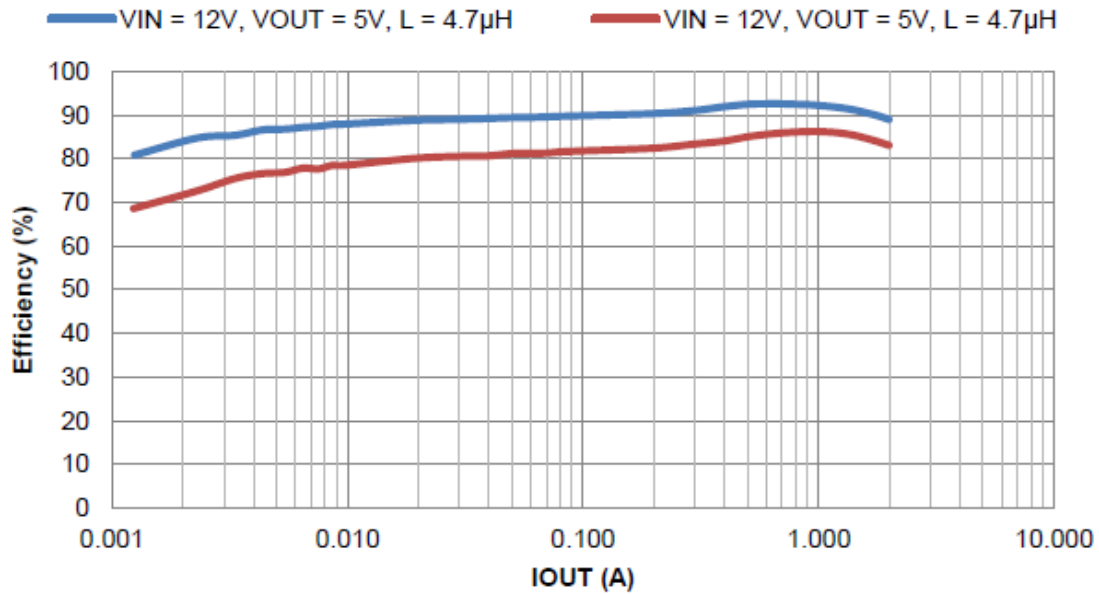

Figure 3. Efficiency vs Output Current

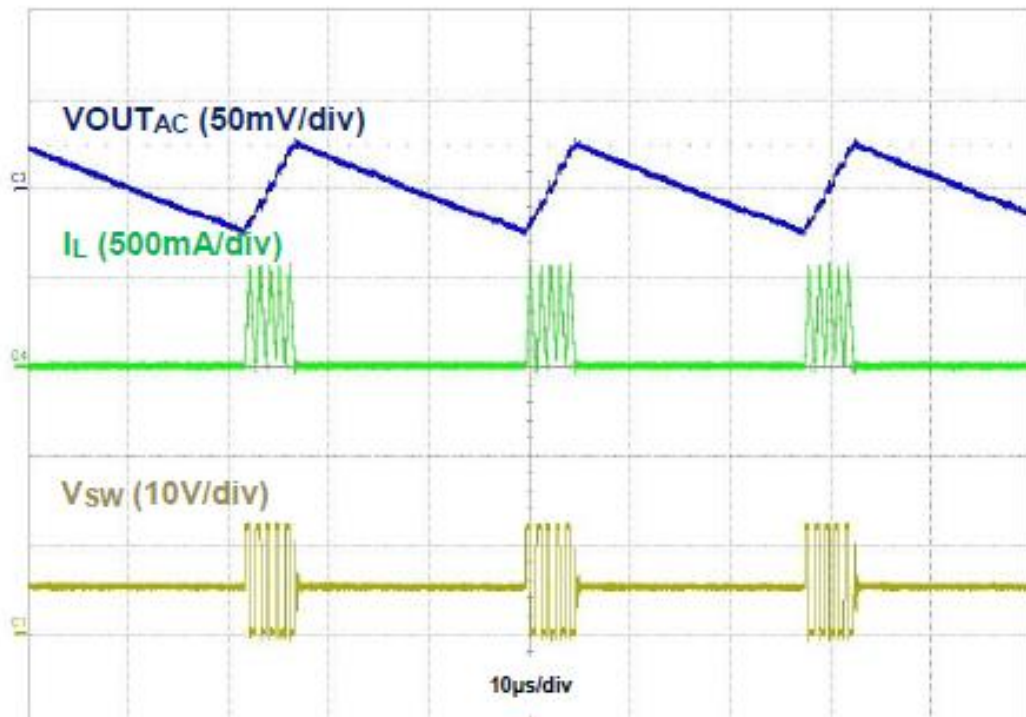

Figure 4. Output Ripple for VIN=12V, VOUT=5.0V, IOUT=50mA

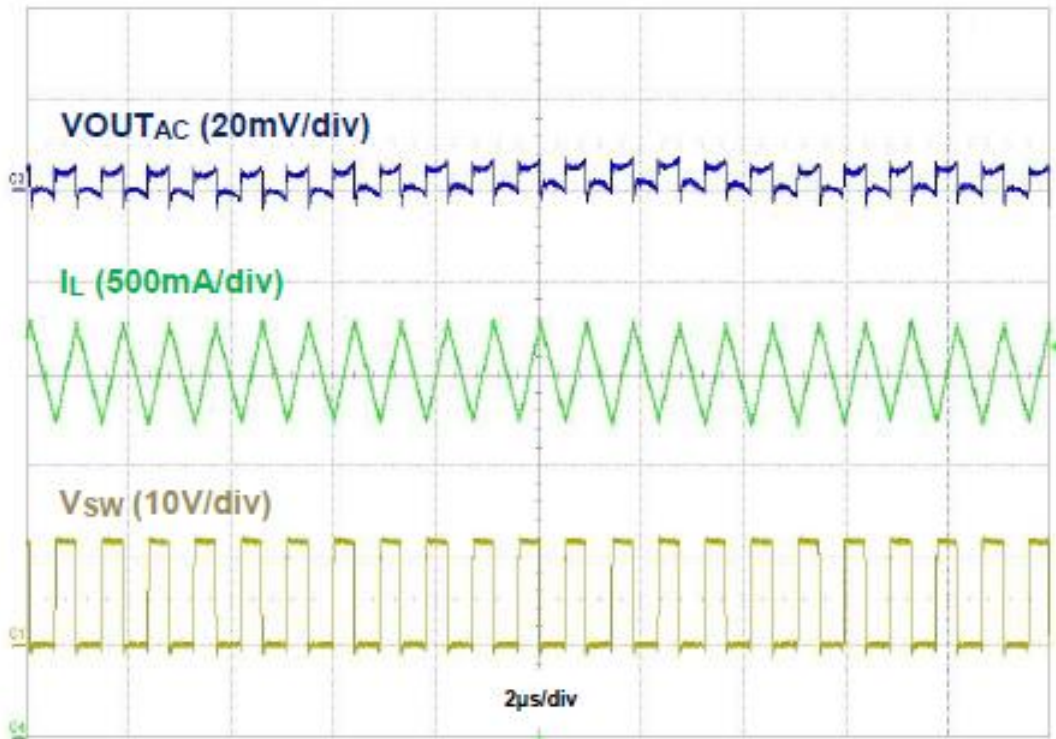

Figure 5. Output Ripple for $V_{IN}=12V$, $V_{OUT}=5.0V$, $I_{OUT}=2A$

IMPORTANT NOTICE

1. DIODES INCORPORATED (Diodes) AND ITS SUBSIDIARIES MAKE NO WARRANTY OF ANY KIND, EXPRESS OR IMPLIED, WITH REGARDS TO ANY INFORMATION CONTAINED IN THIS DOCUMENT, INCLUDING, BUT NOT LIMITED TO, THE IMPLIED WARRANTIES OF MERCHANTABILITY, FITNESS FOR A PARTICULAR PURPOSE OR NON-INFRINGEMENT OF THIRD PARTY INTELLECTUAL PROPERTY RIGHTS (AND THEIR EQUIVALENTS UNDER THE LAWS OF ANY JURISDICTION).
2. The Information contained herein is for informational purpose only and is provided only to illustrate the operation of Diodes' products described herein and application examples. Diodes does not assume any liability arising out of the application or use of this document or any product described herein. This document is intended for skilled and technically trained engineering customers and users who design with Diodes' products. Diodes' products may be used to facilitate safety-related applications; however, in all instances customers and users are responsible for (a) selecting the appropriate Diodes products for their applications, (b) evaluating the suitability of Diodes' products for their intended applications, (c) ensuring their applications, which incorporate Diodes' products, comply the applicable legal and regulatory requirements as well as safety and functional-safety related standards, and (d) ensuring they design with appropriate safeguards (including testing, validation, quality control techniques, redundancy, malfunction prevention, and appropriate treatment for aging degradation) to minimize the risks associated with their applications.
3. Diodes assumes no liability for any application-related information, support, assistance or feedback that may be provided by Diodes from time to time. Any customer or user of this document or products described herein will assume all risks and liabilities associated with such use, and will hold Diodes and all companies whose products are represented herein or on Diodes' websites, harmless against all damages and liabilities.
4. Products described herein may be covered by one or more United States, international or foreign patents and pending patent applications. Product names and markings noted herein may also be covered by one or more United States, international or foreign trademarks and trademark applications. Diodes does not convey any license under any of its intellectual property rights or the rights of any third parties (including third parties whose products and services may be described in this document or on Diodes' website) under this document.
5. Diodes' products are provided subject to Diodes' Standard Terms and Conditions of Sale (<https://www.diodes.com/about/company/terms-and-conditions/terms-and-conditions-of-sales/>) or other applicable terms. This document does not alter or expand the applicable warranties provided by Diodes. Diodes does not warrant or accept any liability whatsoever in respect of any products purchased through unauthorized sales channel.
6. Diodes' products and technology may not be used for or incorporated into any products or systems whose manufacture, use or sale is prohibited under any applicable laws and regulations. Should customers or users use Diodes' products in contravention of any applicable laws or regulations, or for any unintended or unauthorized application, customers and users will (a) be solely responsible for any damages, losses or penalties arising in connection therewith or as a result thereof, and (b) indemnify and hold Diodes and its representatives and agents harmless against any and all claims, damages, expenses, and attorney fees arising out of, directly or indirectly, any claim relating to any noncompliance with the applicable laws and regulations, as well as any unintended or unauthorized application.
7. While efforts have been made to ensure the information contained in this document is accurate, complete and current, it may contain technical inaccuracies, omissions and typographical errors. Diodes does not warrant that information contained in this document is error-free and Diodes is under no obligation to update or otherwise correct this information. Notwithstanding the foregoing, Diodes reserves the right to make modifications, enhancements, improvements, corrections or other changes without further notice to this document and any product described herein. This document is written in English but may be translated into multiple languages for reference. Only the English version of this document is the final and determinative format released by Diodes.
8. Any unauthorized copying, modification, distribution, transmission, display or other use of this document (or any portion hereof) is prohibited. Diodes assumes no responsibility for any losses incurred by the customers or users or any third parties arising from any such unauthorized use.
9. This Notice may be periodically updated with the most recent version available at <https://www.diodes.com/about/company/terms-and-conditions/important-notice>

The Diodes logo is a registered trademark of Diodes Incorporated in the United States and other countries.
All other trademarks are the property of their respective owners.
© 2023 Diodes Incorporated. All Rights Reserved.

www.diodes.com

X-ON Electronics

Largest Supplier of Electrical and Electronic Components

Click to view similar products for [Power Management IC Development Tools](#) *category:*

Click to view products by [Diodes Incorporated](#) *manufacturer:*

Other Similar products are found below :

[EVB-EP5348UI](#) [BQ25010EVM](#) [ISL80019AEVAL1Z](#) [ISLUSBI2CKIT1Z](#) [ISL8002AEVAL1Z](#) [ISL91108IIA-EVZ](#) [MAX8556EVKIT](#)
[MAX15005AEVKIT+](#) [ISL28022EVKIT1Z](#) [STEVAL-ISA008V1](#) [DRI0043](#) [KITPF8100FRDMEVM](#) [EVB-EN6337QA](#)
[SAMPLEBOXILD8150TOBO1](#) [MAX18066EVKIT#](#) [AP62300WU-EVM](#) [KITA2GTC387MOTORCTRTOBO1](#) [AEK-MOT-TK200G1](#)
[EVLONE65W](#) [STEVAL-ILH006V1](#) [STEVAL-IPE008V2](#) [STEVAL-IPP001V2](#) [STEVAL-ISA013V1](#) [STEVAL-ISA067V1](#) [STEVAL-](#)
[ISQ002V1](#) [TPS2306EVM-001](#) [TPS2330EVM-185](#) [TPS40001EVM-001](#) [SECO-HVDCDC1362-15W-GEVB](#) [BTS7030-2EPA](#)
[LT8638SJV#WPBF](#) [LTC3308AIV#WTRPBF](#) [TLT807B0EPV](#) [BTS71033-6ESA](#) [EV13N91A](#) [EASYPIC V8 OVER USB-C](#) [EV55W64A](#)
[CLICKER 4 FOR STM32F4](#) [EASYMX PRO V7A FOR STM32](#) [CLICKER 4 FOR PIC18F](#) [Si8285_86v2-KIT](#) [PAC52700EVK1](#) [NCP-](#)
[NCV51752D2PAK3LGEVB](#) [ISL81807EVAL1Z](#) [AP33772S-EVB](#) [EVALM7HVIGBTFCINV4TOBO1](#) [903-0300-000](#) [902-0173-000](#) [903-](#)
[0301-000](#) [ROA1286023/1](#)