

## Description

The AP64352 is a 3.5A, synchronous buck converter with a wide input voltage range of 3.8V to 40V. The device fully integrates a 75mΩ high-side power MOSFET and a 45mΩ low-side power MOSFET to provide high-efficiency step-down DC-DC conversion.

The AP64352 device is easily used by minimizing the external component count due to its adoption of peak current mode control along with its integrated loop compensation network.

The AP64352 design is optimized for Electromagnetic Interference (EMI) reduction. The device has a proprietary gate driver scheme to resist switching node ringing without sacrificing MOSFET turn-on and turn-off times, which reduces high-frequency radiated EMI noise caused by MOSFET switching. AP64352 also features Frequency Spread Spectrum (FSS) with a switching frequency jitter of  $\pm 6\%$ , which reduces EMI by not allowing emitted energy to stay in any one frequency for a significant period of time.

The device is available in an SO-8EP package.

## Features

- VIN 3.8V to 40V
- 3.5A Continuous Output Current
- $0.8V \pm 1\%$  Reference Voltage
- 22 $\mu$ A Low Quiescent Current (Pulse Frequency Modulation)
- Programmable Switching Frequency: 100kHz to 2.2MHz
- External Clock Synchronization: 100kHz to 2.2MHz
- Programmable Soft-Start Time
- Up to 85% Efficiency at 5mA Light Load
- Proprietary Gate Driver Design for Best EMI Reduction
- Frequency Spread Spectrum (FSS) to Reduce EMI
- Low-Dropout (LDO) Mode
- Precision Enable Threshold to Adjust UVLO
- Protection Circuitry
  - Undervoltage Lockout (UVLO)
  - Output Overvoltage Protection (OVP)
  - Cycle-by-Cycle Peak Current Limit
  - Thermal Shutdown
- **Totally Lead-Free & Fully RoHS Compliant (Notes 1 & 2)**
- **Halogen and Antimony Free. "Green" Device (Note 3)**

## Pin Assignments

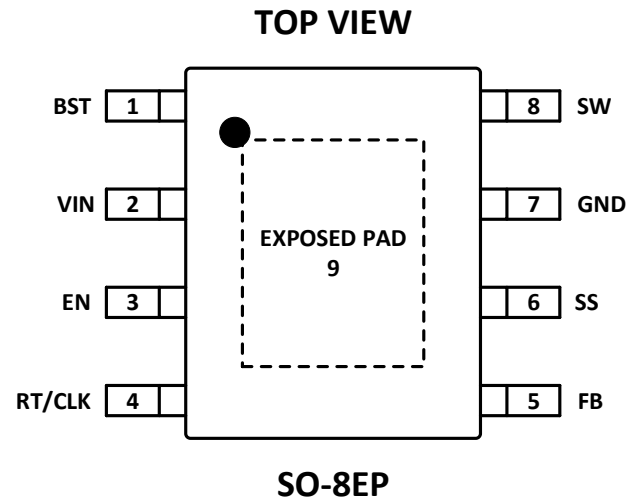

## Typical Application Circuit

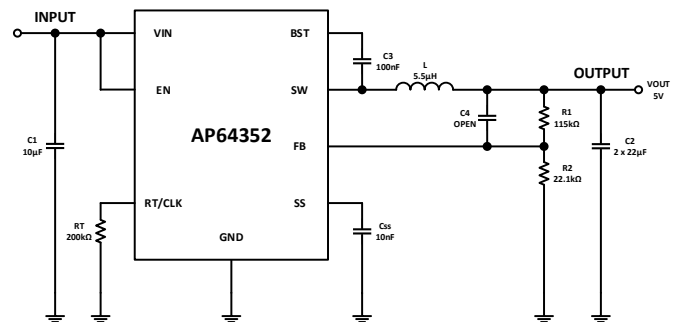

—  $V_{OUT} = 5V, L = 5.5\mu H$  —  $V_{OUT} = 3.3V, L = 4.7\mu H$

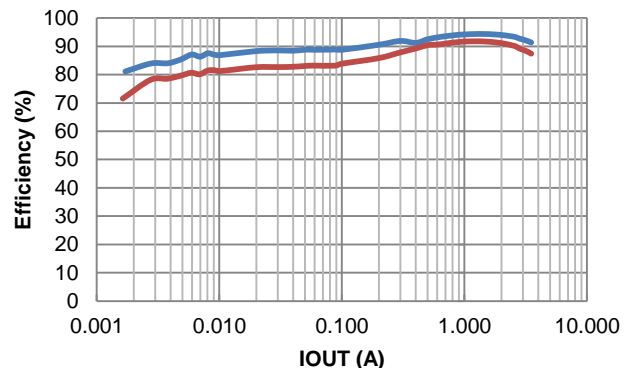

- Notes:
1. No purposely added lead. Fully EU Directive 2002/95/EC (RoHS), 2011/65/EU (RoHS 2) & 2015/863/EU (RoHS 3) compliant.
  2. See <https://www.diodes.com/quality/lead-free/> for more information about Diodes Incorporated's definitions of Halogen- and Antimony-free, "Green" and Lead-free.
  3. Halogen- and Antimony-free "Green" products are defined as those which contain <900ppm bromine, <900ppm chlorine (<1500ppm total Br + Cl) and <1000ppm antimony compounds.

## Pin Descriptions

Pin Name	Pin Number	Function
BST	1	High-Side Gate Drive Boost Input. BST supplies the drive for the high-side N-Channel power MOSFET. A 100nF capacitor is recommended from BST to SW to power the high-side driver.
VIN	2	Power Input. VIN supplies the power to the IC as well as the step-down converter power MOSFETs. Drive VIN with a 3.8V to 40V power source. Bypass VIN to GND with a suitably large capacitor to eliminate noise due to the switching of the IC. See <b>Input Capacitor</b> section for more details.
EN	3	Enable Input. EN is a digital input that turns the regulator on or off. Drive EN high to turn on the regulator and low to turn it off. Connect to VIN or leave floating for automatic startup. The EN has a precision threshold of 1.18V for programming the UVLO. See <b>Enable</b> section for more details.
RT/CLK	4	Resistor Timing and External Clock. This pin can be used to control the switching frequency by setting the internal oscillator frequency or by synchronizing to an external clock. Connect a resistor from RT/CLK to GND to set the internal oscillator frequency. An external clock can be input directly to the RT/CLK pin and the internal oscillator synchronizes to the external clock frequency using a PLL. If the external clock edges stop, the operating mode automatically returns to resistor frequency programming. See <b>Programming Switching Frequency</b> section for more details.
FB	5	Feedback sensing terminal for the output voltage. Connect this pin to the resistive divider of the output. See <b>Setting the Output Voltage</b> section for more details.
SS	6	Soft-start. Place a ceramic capacitor from this pin to ground to program soft-start time. An internal 4 $\mu$ A current source pulls the SS pin to VCC. See <b>Programming Soft-Start Time</b> section for more details.
GND	7	Power Ground.
SW	8	Power Switching Output. SW is the switching node that supplies power to the output. Connect the output LC filter from SW to the output load.
EXPOSED PAD	9	Heat dissipation path of the die. The exposed thermal pad must be electrically connected to GND and must be connected to the ground plane of the PCB for proper operation and optimized thermal performance.

## Absolute Maximum Ratings (Note 4) (At $T_A = +25^\circ\text{C}$ , unless otherwise specified.)

Symbol	Parameter	Rating	Unit
VIN	Supply Pin Voltage	-0.3 to +42.0 (DC)	V
		-0.3 to +45.0 (400ms)	
V <sub>BST</sub>	Bootstrap Pin Voltage	$V_{SW} - 0.3$ to $V_{SW} + 6.0$	V
V <sub>EN</sub>	Enable/UVLO Pin Voltage	-0.3 to +42.0	V
V <sub>RT/CLK</sub>	RT/CLK Pin Voltage	-0.3 to +6.0	V
V <sub>FB</sub>	Feedback Pin Voltage	-0.3 to +6.0	V
V <sub>SS</sub>	Soft-Start Pin Voltage	-0.3 to +6.0	V
V <sub>SW</sub>	Switch Pin Voltage	-0.3 to VIN + 0.3 (DC)	V
		-2.5 to VIN + 2.0 (20ns)	
T <sub>ST</sub>	Storage Temperature	-65 to +150	$^\circ\text{C}$
T <sub>J</sub>	Junction Temperature	+160	$^\circ\text{C}$
T <sub>L</sub>	Lead Temperature	+260	$^\circ\text{C}$
<b>ESD Susceptibility (Note 5)</b>			
HBM	Human Body Model	2000	V
CDM	Charged Device Model	500	V

- Notes:
- Stresses greater than the **Absolute Maximum Ratings** specified above may cause permanent damage to the device. These are stress ratings only; functional operation of the device at these or any other conditions exceeding those indicated in this specification is not implied. Device reliability may be affected by exposure to absolute maximum rating conditions for extended periods of time.
  - Semiconductor devices are ESD sensitive and may be damaged by exposure to ESD events. Suitable ESD precautions should be taken when handling and transporting these devices.

## Thermal Resistance (Note 6)

Symbol	Parameter	Rating		Unit
$\theta_{JA}$	Junction to Ambient	SO-8EP	45	$^{\circ}\text{C}/\text{W}$
$\theta_{JC}$	Junction to Case	SO-8EP	5	$^{\circ}\text{C}/\text{W}$

Note: 6. Test condition for SO-8EP: Device mounted on FR-4 substrate, four-layer PC board, 2oz copper, with minimum recommended pad layout.

## Recommended Operating Conditions (Note 7) (At $T_A = +25^{\circ}\text{C}$ , unless otherwise specified.)

Symbol	Parameter	Min	Max	Unit
VIN	Supply Voltage	3.8	40	V
VOUT	Output Voltage	0.8	VIN	V
$T_A$	Operating Ambient Temperature Range	-40	+85	$^{\circ}\text{C}$
$T_J$	Operating Junction Temperature Range	-40	+125	$^{\circ}\text{C}$

Note: 7. The device function is not guaranteed outside of the recommended operating conditions.

## Electrical Characteristics (At $T_A = +25^{\circ}\text{C}$ , VIN = 12V, unless otherwise specified. Min/Max limits apply across the recommended ambient temperature range, $-40^{\circ}\text{C}$ to $+85^{\circ}\text{C}$ , and input voltage range, 3.8V to 40V, unless otherwise specified.)

Symbol	Parameter	Test Conditions	Min	Typ	Max	Unit
$I_{SHDN}$	Shutdown Supply Current	$V_{EN} = 0\text{V}$	—	1	5	$\mu\text{A}$
$I_Q$	Quiescent Supply Current	$V_{EN} = \text{Floating}, V_{FB} = 1.0\text{V}$	—	22	—	$\mu\text{A}$
UVLO	VIN Undervoltage Rising Threshold	—	—	3.5	3.7	V
	VIN Undervoltage Hysteresis	—	—	400	—	mV
$R_{DS(ON)1}$	High-Side Power MOSFET On-Resistance (Note 8)	—	—	75	—	$\text{m}\Omega$
$R_{DS(ON)2}$	Low-Side Power MOSFET On-Resistance (Note 8)	—	—	45	—	$\text{m}\Omega$
$I_{PEAK\_LIMIT}$	HS Peak Current Limit (Note 8)	—	4.25	5	5.75	A
$I_{VALLEY\_LIMIT}$	LS Valley Current Limit (Note 8)	—	—	5.5	—	A
$I_{PFMPK}$	PFM Peak Current Limit	—	—	750	—	mA
$I_{ZC}$	Zero Cross Current Threshold	—	—	0	—	mA
$f_{RANGE\_RT}$	Frequency Range Using RT	—	100	—	2200	kHz
$f_{SW}$	Oscillator Frequency	RT = 200k $\Omega$ ( $\pm 1\%$ )	450	500	550	kHz
$f_{RANGE\_CLK}$	Frequency Range Using External CLK	—	100	—	2200	kHz
$t_{ON\_MIN}$	Minimum On-Time	—	—	100	—	ns
$V_{FB}$	Feedback Voltage	CCM	792	800	808	mV
$V_{EN\_H}$	EN Logic High Threshold	—	—	1.18	1.25	V
$V_{EN\_L}$	EN Logic Low Threshold	—	1.03	1.09	—	V
$I_{EN}$	EN Input Current	$V_{EN} = 1.5\text{V}$	—	5.5	—	$\mu\text{A}$
		$V_{EN} = 1\text{V}$	1	1.5	2	$\mu\text{A}$
$t_{SS}$	Soft-Start Time	$C_{SS} = 10\text{nF}$	—	2	—	ms
$T_{SD}$	Thermal Shutdown (Note 8)	—	—	160	—	$^{\circ}\text{C}$
$T_{Hys}$	Thermal Shutdown Hysteresis (Note 8)	—	—	25	—	$^{\circ}\text{C}$

Note: 8. Compliance to the datasheet limits is assured by one or more methods: production test, characterization, and/or design.

## Ordering Information

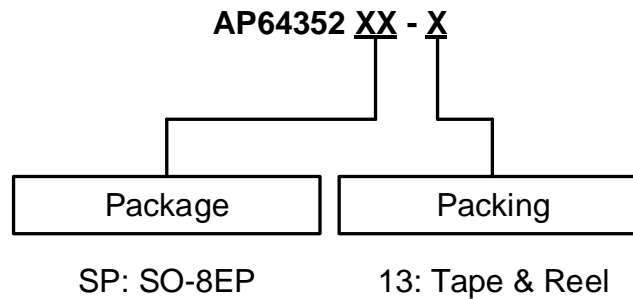

Orderable Device	Package Code	Tape and Reel	
		Quantity	Part Number Suffix
AP64352SP-13	SP	4000	-13

## Marking Information

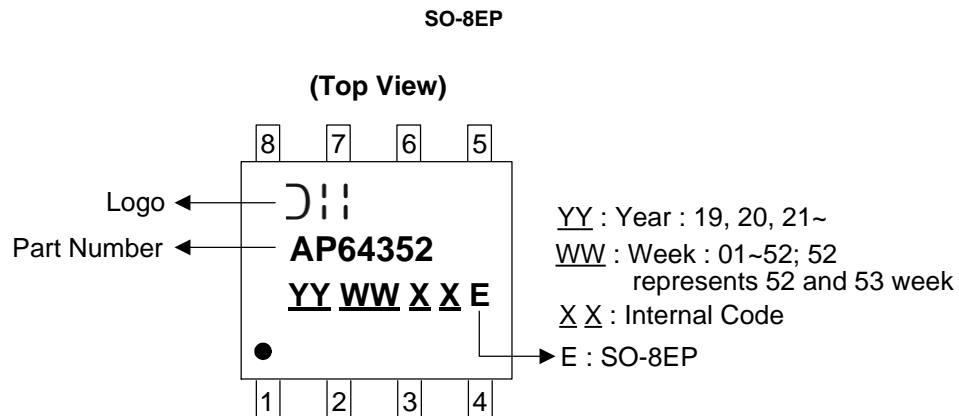

## Device Comparison Table

Part Name	V <sub>IN</sub> (V)	V <sub>OUT</sub> (V)	Output Current (A)	HS / LS R <sub>DS(ON)</sub> (mΩ)	Switching Frequency (kHz)	I <sub>q</sub> (μA)	Key Features	Ambient Temperature (°C)	Package
AP64350	3.8 to 40	0.8 to V <sub>IN</sub>	3.5	75 / 45	100 to 2200	22	Prog. Fsw, Ext. Sync, Ext. Comp	-40 to +85	SO-8EP
AP64351	3.8 to 40	0.8 to V <sub>IN</sub>	3.5	75 / 45	570	22	Prog. SS, Ext. Comp	-40 to +85	SO-8EP
AP64352	3.8 to 40	0.8 to V <sub>IN</sub>	3.5	75 / 45	100 to 2200	22	Prog. Fsw, Ext. Sync, Ext. SS	-40 to +85	SO-8EP
AP64500	3.8 to 40	0.8 to V <sub>IN</sub>	5.0	45 / 20	100 to 2200	25	Prog. Fsw, Ext. Sync, Ext. Comp	-40 to +85	SO-8EP
AP64501	3.8 to 40	0.8 to V <sub>IN</sub>	5.0	45 / 20	570	25	Prog. SS, Ext. Comp	-40 to +85	SO-8EP

**IMPORTANT NOTICE**

DIODES INCORPORATED MAKES NO WARRANTY OF ANY KIND, EXPRESS OR IMPLIED, WITH REGARDS TO THIS DOCUMENT, INCLUDING, BUT NOT LIMITED TO, THE IMPLIED WARRANTIES OF MERCHANTABILITY AND FITNESS FOR A PARTICULAR PURPOSE (AND THEIR EQUIVALENTS UNDER THE LAWS OF ANY JURISDICTION).

Diodes Incorporated and its subsidiaries reserve the right to make modifications, enhancements, improvements, corrections or other changes without further notice to this document and any product described herein. Diodes Incorporated does not assume any liability arising out of the application or use of this document or any product described herein; neither does Diodes Incorporated convey any license under its patent or trademark rights, nor the rights of others. Any Customer or user of this document or products described herein in such applications shall assume all risks of such use and will agree to hold Diodes Incorporated and all the companies whose products are represented on Diodes Incorporated website, harmless against all damages.

Diodes Incorporated does not warrant or accept any liability whatsoever in respect of any products purchased through unauthorized sales channel. Should Customers purchase or use Diodes Incorporated products for any unintended or unauthorized application, Customers shall indemnify and hold Diodes Incorporated and its representatives harmless against all claims, damages, expenses, and attorney fees arising out of, directly or indirectly, any claim of personal injury or death associated with such unintended or unauthorized application.

Products described herein may be covered by one or more United States, international or foreign patents pending. Product names and markings noted herein may also be covered by one or more United States, international or foreign trademarks.

This document is written in English but may be translated into multiple languages for reference. Only the English version of this document is the final and determinative format released by Diodes Incorporated.

**LIFE SUPPORT**

Diodes Incorporated products are specifically not authorized for use as critical components in life support devices or systems without the express written approval of the Chief Executive Officer of Diodes Incorporated. As used herein:

A. Life support devices or systems are devices or systems which:

1. are intended to implant into the body, or
2. support or sustain life and whose failure to perform when properly used in accordance with instructions for use provided in the labeling can be reasonably expected to result in significant injury to the user.

B. A critical component is any component in a life support device or system whose failure to perform can be reasonably expected to cause the failure of the life support device or to affect its safety or effectiveness.

Customers represent that they have all necessary expertise in the safety and regulatory ramifications of their life support devices or systems, and acknowledge and agree that they are solely responsible for all legal, regulatory and safety-related requirements concerning their products and any use of Diodes Incorporated products in such safety-critical, life support devices or systems, notwithstanding any devices- or systems-related information or support that may be provided by Diodes Incorporated. Further, Customers must fully indemnify Diodes Incorporated and its representatives against any damages arising out of the use of Diodes Incorporated products in such safety-critical, life support devices or systems.

Copyright © 2019, Diodes Incorporated

[www.diodes.com](http://www.diodes.com)

## X-ON Electronics

Largest Supplier of Electrical and Electronic Components

*Click to view similar products for [Switching Voltage Regulators](#) category:*

*Click to view products by [Diodes Incorporated](#) manufacturer:*

Other Similar products are found below :

[FAN53610AUC33X](#) [FAN53611AUC123X](#) [FAN48610BUC33X](#) [FAN48610BUC45X](#) [FAN48617UC50X](#) [R3](#) [430464BB](#) [MIC45116-1YMP-T1](#) [KE177614](#) [MAX809TTR](#) [NCV891234MW50R2G](#) [NCP81103MNTXG](#) [NCP81203PMNTXG](#) [NCP81208MNTXG](#) [NCP81109GMNTXG](#) [SCY1751FCCT1G](#) [NCP81109JMNTXG](#) [AP3409ADNTR-G1](#) [LTM8064IY](#) [LT8315EFE#TRPBF](#) [NCV1077CSTBT3G](#) [DA9121-B0V76](#) [LTC3644IY#PBF](#) [LD8116CGL](#) [HG2269M/TR](#) [OB2269](#) [XD3526](#) [U6215A](#) [U6215B](#) [U6620S](#) [LTC3803ES6#TR](#) [LTC3803ES6#TRM](#) [LTC3412IFE](#) [LT1425IS](#) [MAX25203BATJA/VY+](#) [MAX77874CEWM+](#) [XC9236D08CER-G](#) [ISL95338IRTZ](#) [MP3416GJ-P](#) [BD9S201NUX-CE2](#) [MP5461GC-Z](#) [MPQ4415AGQB-Z](#) [MPQ4590GS-Z](#) [LX7178-01CSP-TR](#) [MCP1642B-18IMC](#) [MCP1642D-ADJIMC](#) [MCP1642D-18IMC](#) [MCP1642D-30IMC](#) [MCP1665T-E/MRA](#) [MIC2876-4.75YMT-T5](#)