

Description

The AP7383 series is a positive voltage regulator IC.

The AP7383 features a wide-input voltage range, high-accuracy, low-dropout voltage, current limit and ultra-low quiescent current; all of which makes it ideal for use in various USB, portable devices, and instrument application.

The IC consists of a voltage reference, an error amplifier, a resistor network for setting output voltage, a current-limit circuit for current protection, and a chip enable circuit.

The AP7383 is available in 1.8V, 3.0V, 3.3V, 3.45V, 3.6V, 4.15V, 4.4V and 5.0V fixed-output voltage versions.

The AP7383 is available in space-saving SOT25, SOT89 and U-DFN2020-6 (Type C) packages.

Features

- Wide Input Voltage Range: Up to 30V
- Low Dropout Voltage: $V_{DROP} = 500mV @ I_{OUT} = 50mA$
- Low Ground Current
- High Output Voltage Accuracy
- Compatible with Low ESR Ceramic Capacitor
- Excellent Line/Load Regulation
- Thermal Shutdown Function
- Moisture Sensitivity:
 - SOT25/U-DFN2020-6 (Type C): Level 1 per J-STD-020
 - SOT89: Level 3 per J-STD-020
- Terminals:
 - SOT25/SOT89: Finish – Matte Tin Plated Leads, Solderable per MIL-STD-202, Method 208 (e3)
 - U-DFN2020-6 (Type C): Finish NiPdAu over Copper Lead-Frame. Solderable per MIL-STD-202, Method 208 (e4)
- Weight:
 - SOT25: 0.016 grams (Approximate)
 - SOT89: 0.055 grams (Approximate)
 - U-DFN2020-6 (Type C): 0.007 grams (Approximate)
- **Totally Lead-Free & Fully RoHS Compliant (Notes 1 & 2)**
- **Halogen- and Antimony-Free. “Green” Device (Note 3)**
- **For automotive applications requiring specific change control (i.e. parts qualified to AEC-Q100/101/200, PPAP capable, and manufactured in IATF 16949 certified facilities), please [contact us](mailto:contact@diodes.com) or your local Diodes representative. <https://www.diodes.com/quality/product-definitions/>**

Applications

- Battery-Powered Equipment
- Laptop, Palmtops, Notebook Computers
- Portable Information Appliances

Notes: 1. No purposely added lead. Fully EU Directive 2002/95/EC (RoHS), 2011/65/EU (RoHS 2) & 2015/863/EU (RoHS 3) compliant.
 2. See <https://www.diodes.com/quality/lead-free/> for more information about Diodes Incorporated's definitions of Halogen- and Antimony-free, "Green" and Lead-free.
 3. Halogen- and Antimony-free "Green" products are defined as those which contain <900ppm bromine, <900ppm chlorine (<1500ppm total Br + Cl) and <1000ppm antimony compounds.

Pin Assignments

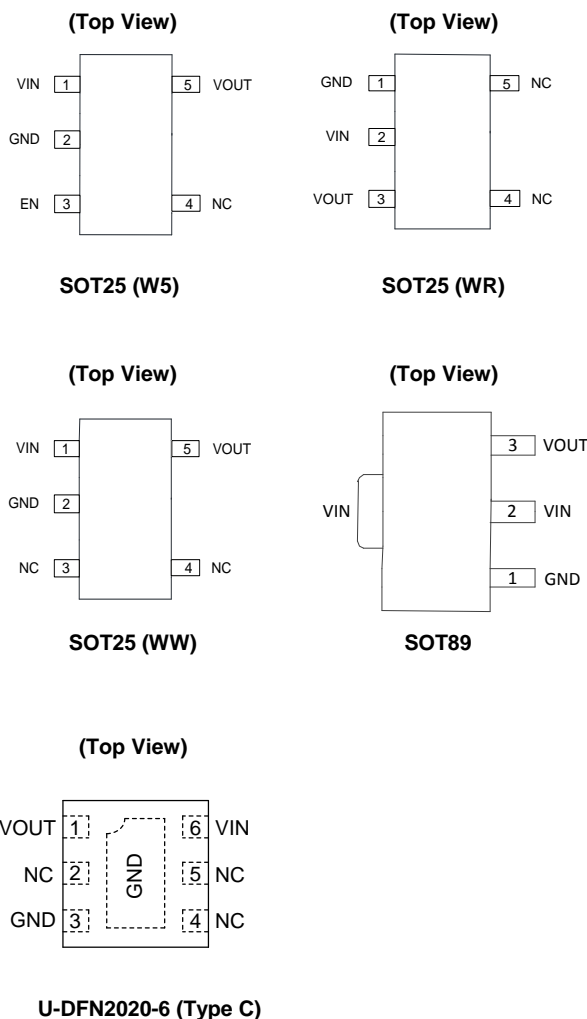

Typical Applications Circuit

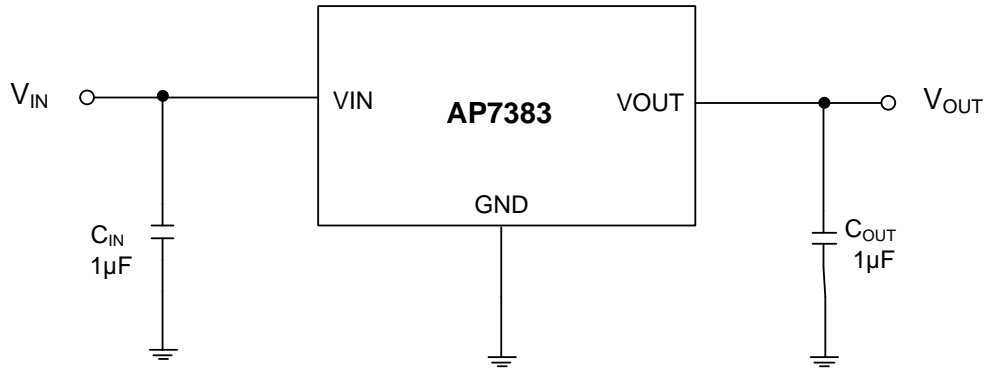

SOT89 / SOT25 (WR/WW Package) / U-DFN2020-6 (Type C)

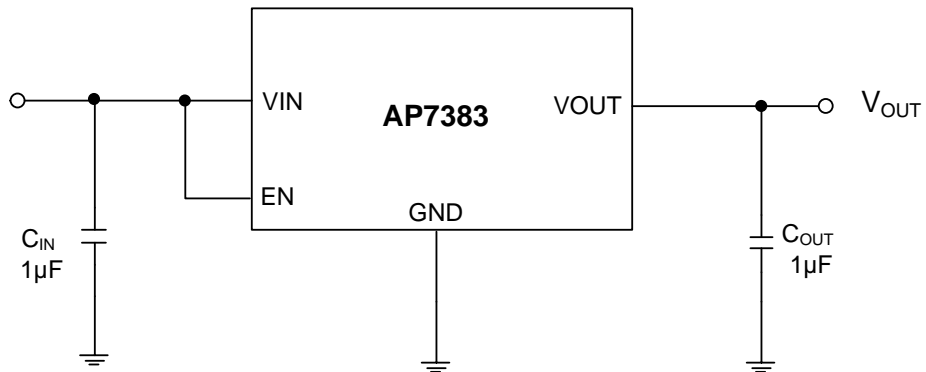

SOT25 (W5 Package)

Pin Descriptions

Pin Number					Pin Name	Function
SOT25 (W5 Package)	SOT25 (WR Package)	SOT25 (WW Package)	SOT89	U-DFN2020-6 (Type C)		
1	2	1	2	6	VIN	Input Voltage
2	1	2	1	3	GND	Ground
3	—	—	—	—	EN	Enable Input
4	4, 5	3, 4	—	2, 4, 5	NC	- Not connected for fixed version. - Not connected internally, recommend connection to GND to maximize PCB copper for thermal dissipation.
5	3	5	3	1	VOUT	Regulated Output Voltage

Absolute Maximum Ratings (Note 4) (@ $T_A = +25^\circ\text{C}$, unless otherwise specified.)

Symbol	Parameter	Rating		Unit
V_{IN}	Supply Input Voltage	33		V
V_{EN}	Enable Input Voltage	33		V
I_{OUT}	Output Current	200		mA
T_{LEAD}	Lead Temperature (Soldering, 10s)	+260		$^\circ\text{C}$
T_J	Operating Junction Temperature	+150		$^\circ\text{C}$
P_D	Power Dissipation	SOT25 (W5/WW Package)	518	mW
		SOT25 (WR Package)	602	
		SOT89	847	
		U-DFN2020-6 (Type C)	658	
Θ_{JA}	Thermal Resistance (Junction to Ambient)	SOT25 (W5/WW Package)	193	$^\circ\text{C/W}$
		SOT25 (WR Package)	166	
		SOT89	118	
		U-DFN2020-6 (Type C)	152	
Θ_{JC}	Thermal Resistance (Junction to Case)	SOT25 (W5/WW Package)	68	$^\circ\text{C/W}$
		SOT25 (WR Package)	26	
		SOT89	20	
		U-DFN2020-6 (Type C)	58	
T_{STG}	Storage Temperature Range	-65 to +150		$^\circ\text{C}$
—	ESD (Machine Model)	250		V
—	ESD (Human Body Model)	2500		V

Note: 4. a). Stresses beyond those listed under Absolute Maximum Ratings can cause permanent damage to the device. These are stress ratings only, and functional operation of the device at these conditions is not implied. Exposure to absolute-maximum-rated conditions for extended periods can affect device reliability.
 b). Ratings apply to ambient temperature at +25 $^\circ\text{C}$. The JEDEC High-K board design used to derive this data is a 2inch x 2inch multi-layer board with 1oz internal power and ground planes and 2oz copper traces on the top and bottom of the board.

Recommended Operating Conditions

Symbol	Parameter	Min	Max	Unit
V_{IN}	Supply Input Voltage	3.5	30	V
T_J	Operating Junction Temperature	-40	+125	$^\circ\text{C}$

Electrical Characteristics (@ $V_{IN} = V_{OUT} + 2V$, $C_{IN} = 1.0\mu F$, $C_{OUT} = 1.0\mu F$, Typical $T_J = +25^\circ C$, unless otherwise specified.)

Symbol	Parameter	Test Conditions	Min	Typ	Max	Unit	
V_{OUT}	Output Voltage	$V_{IN} = V_{OUT} + 2V$, $I_{OUT} = 10mA$ Variation from Specified V_{OUT}	$V_{OUT} \times 99\%$	V_{OUT}	$V_{OUT} \times 101\%$	V	
V_{IN}	Input Voltage	—	3.5	—	30	V	
I_{LIMIT}	Current Limit	$V_{IN} = V_{OUT} + 2V$, $V_{OUT1} = 98\% \times V_{OUT}$	150	—	—	mA	
$\Delta V_{OUT}/\Delta V_{IN}/V_{OUT}$	Line Regulation	$V_{OUT} + 2V \leq V_{IN} \leq 30V$, $I_{OUT} = 10mA$	—	0.05	—	%/V	
$\Delta V_{OUT}/V_{OUT}$	Load Regulation	$V_{IN} = V_{OUT} + 2V$, $1mA \leq I_{OUT} \leq 150mA$	—	0.5	—	%	
V_{DROP}	Dropout Voltage	$3.0V \leq V_{OUT} < 5.0V$	$I_{OUT} = 50mA$	—	360	580	mV
			$I_{OUT} = 100mA$	—	750	1000	mV
			$I_{OUT} = 150mA$	—	1050	1500	mV
		$V_{OUT} = 5.0V$	$I_{OUT} = 50mA$	—	250	500	mV
			$I_{OUT} = 100mA$	—	550	750	mV
			$I_{OUT} = 150mA$	—	750	1100	mV
I_{GND}	Ground Current	$I_{OUT} = 0A$	—	1.8	3.0	μA	
		$I_{OUT} = 150mA$	—	1.8	3.0		
I_{STD}	Standby Current	V_{EN} in OFF Mode	—	0.01	—	μA	
$\Delta V_{OUT}/(V_{OUT} \times \Delta T)$	Output Voltage Temperature Coefficient	$I_{OUT} = 100\mu A$, $-40^\circ C \leq T_J \leq +125^\circ C$	—	± 100	—	ppm/ $^\circ C$	
I_{EN}	EN Pin Current	—	—	1	—	μA	
—	EN "High" Voltage	EN Input Voltage "High"	2.0	—	—	V	
—	EN "Low" Voltage	EN Input Voltage "Low"	—	—	0.4	V	
T_{OTSD}	Thermal Shutdown Temperature	—	—	+160	—	$^\circ C$	
T_{HYOTSD}	Thermal Shutdown Hysteresis	—	—	+20	—	$^\circ C$	

Performance Characteristics

Output Voltage vs. Input Voltage @-40°C

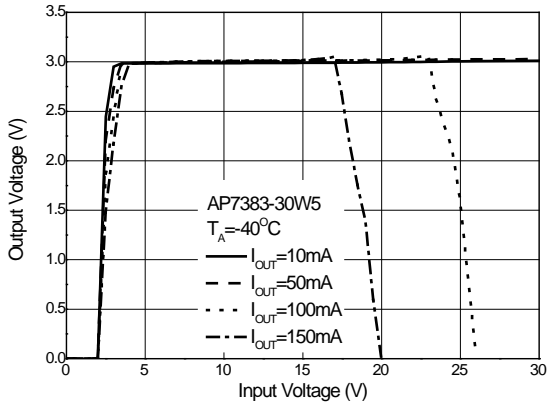

Output Voltage vs. Input Voltage @+25°C

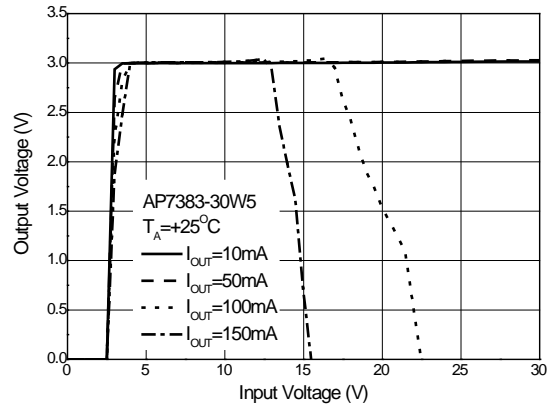

Output Voltage vs. Input Voltage @+85°C

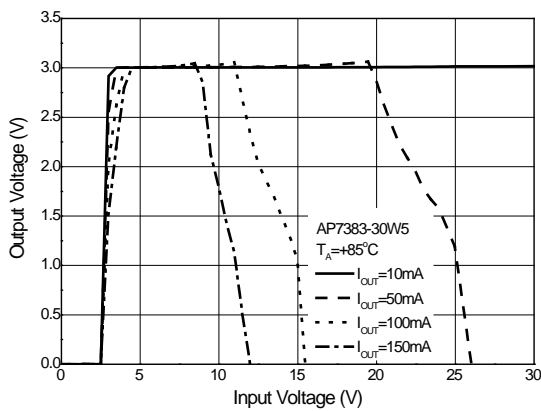

Output Voltage vs. Output Current

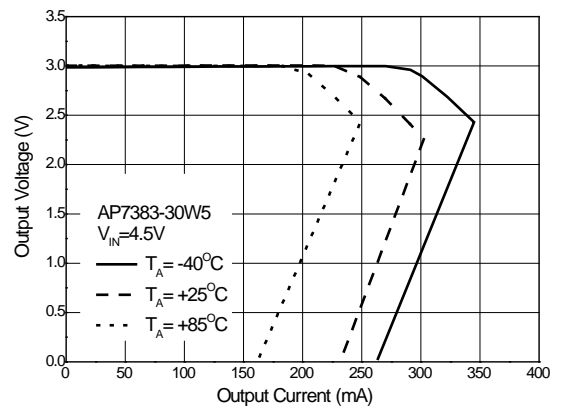

Output Voltage vs. Temperature

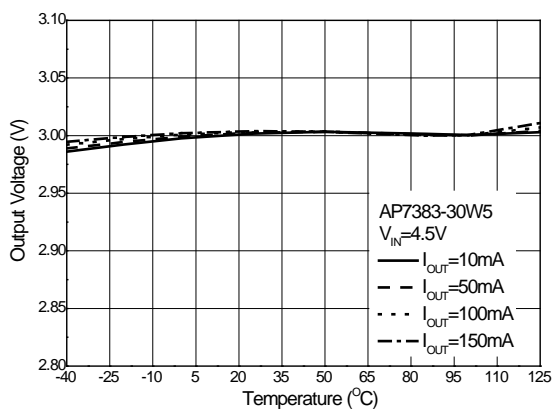

Output Voltage vs. Output Current

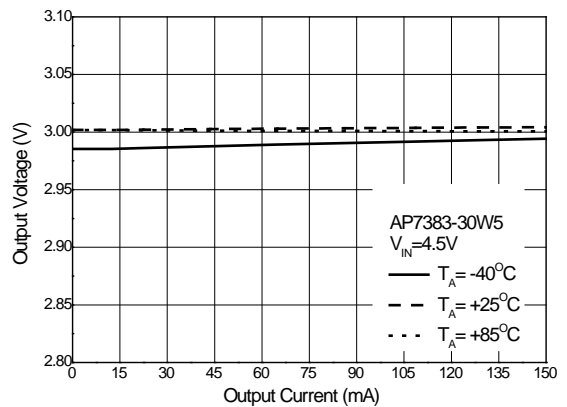

Performance Characteristics (continued)

Dropout Voltage vs. Output Current

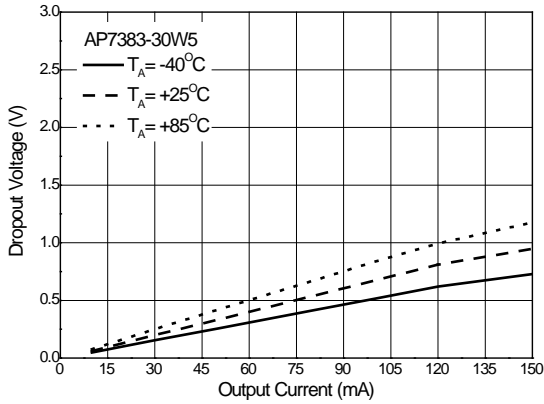

Dropout Voltage vs. Temperature

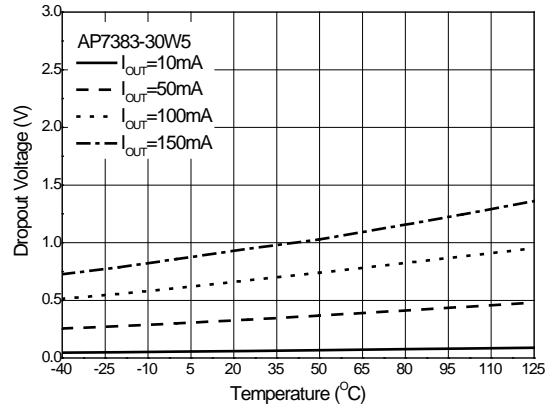

I_{GND} vs. Input Voltage

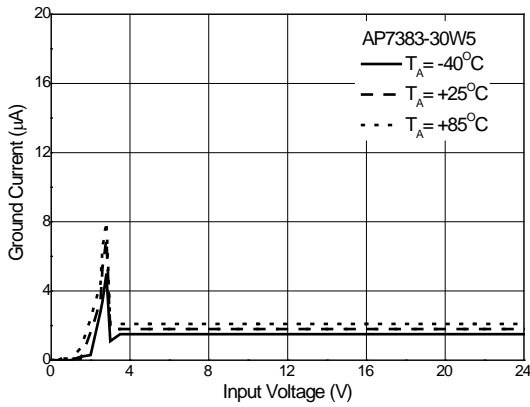

I_{GND} vs. Output Current

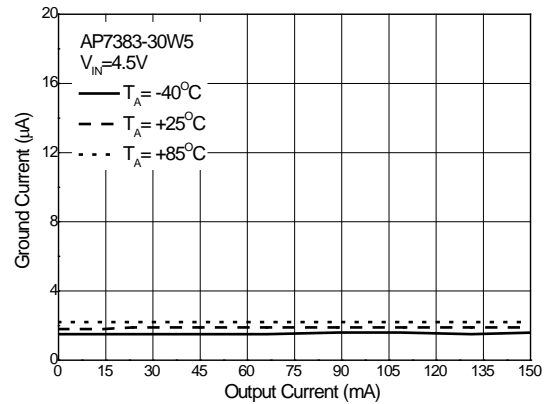

I_{GND} vs. Temperature

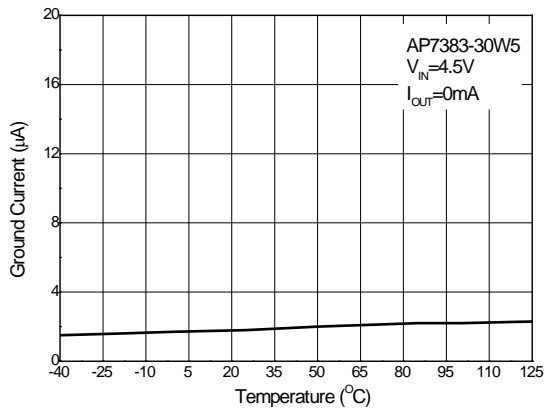

Load Transient

$C_{IN} = 1\mu\text{F}$, $C_{OUT} = 1\mu\text{F}$, $V_{IN} = V_{OUT} + 1.5\text{V}$ to 30V , $I_{OUT} = 0$ to 50mA

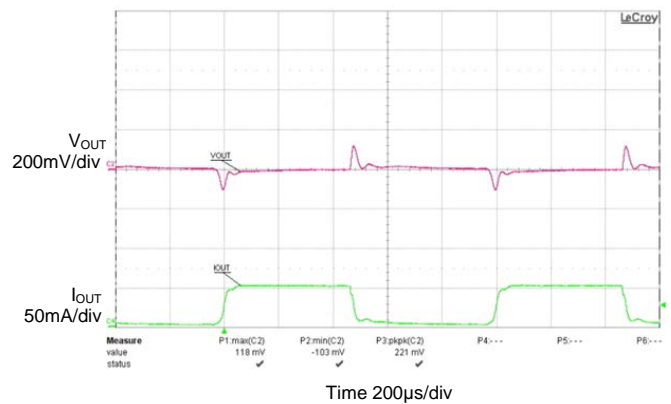

Ordering Information

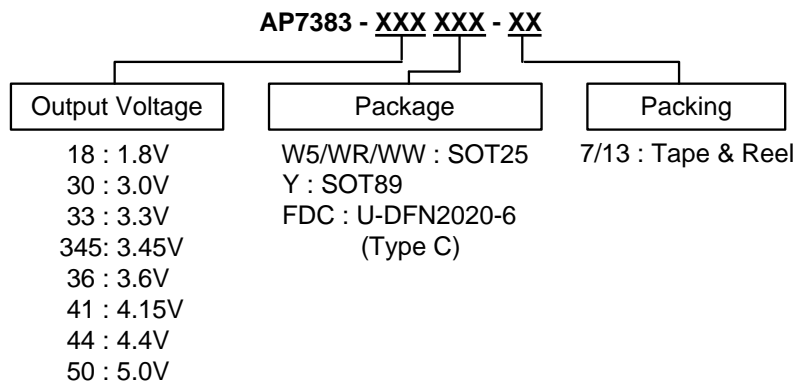

Part Number	Package Code	Package	7"/13" Tape and Reel	
			Quantity	Part Number Suffix
AP7383-XXW5-7	W5	SOT25	3000/Tape & Reel	-7
AP7383-XXWR-7	WR	SOT25	3000/Tape & Reel	-7
AP7383-XXWW-7	WW	SOT25	3000/Tape & Reel	-7
AP7383-XXY-13	Y	SOT89	2500/Tape & Reel	-13
AP7383-XXFDC-7	FDC	U-DFN2020-6 (Type C)	3000/Tape & Reel	-7

NEW PRODUCT

Marking Information

(1) SOT25

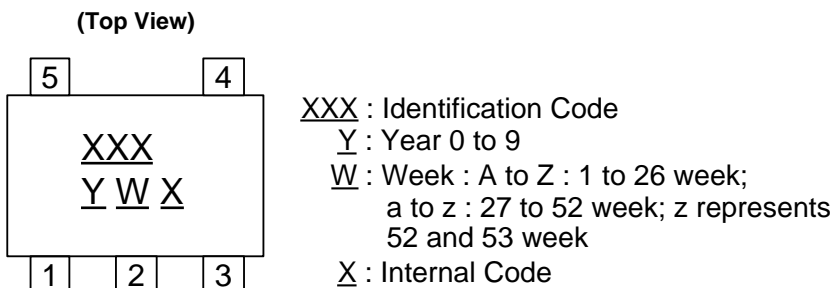

Part Number	Package	Identification Code
AP7383-18W5-7	SOT25	F3A
AP7383-30W5-7	SOT25	F3B
AP7383-33W5-7	SOT25	F3C
AP7383-36W5-7	SOT25	F3D
AP7383-41W5-7	SOT25	F3E
AP7383-44W5-7	SOT25	F3F
AP7383-50W5-7	SOT25	F3G
AP7383-18WR-7	SOT25	F3H
AP7383-30WR-7	SOT25	F3J
AP7383-33WR-7	SOT25	F3K
AP7383-345WR-7	SOT25	F3Z
AP7383-36WR-7	SOT25	F3M
AP7383-41WR-7	SOT25	F3N
AP7383-44WR-7	SOT25	F3P
AP7383-50WR-7	SOT25	F3R
AP7383-18WW-7	SOT25	F3S
AP7383-30WW-7	SOT25	F3T
AP7383-33WW-7	SOT25	F3U
AP7383-36WW-7	SOT25	F3V
AP7383-41WW-7	SOT25	F3W
AP7383-44WW-7	SOT25	F3X
AP7383-50WW-7	SOT25	F3Y

Marking Information (continued)

(2) SOT89

(Top View)

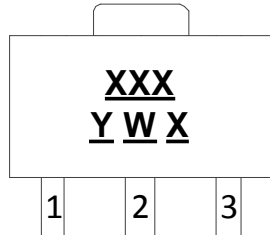

XXX : Identification code
Y : Year : 0~9
W : Week : A~Z : 1~26 week;
a~z : 27~52 week;
z represents 52 and 53 week
X : Internal code

Part Number	Package	Identification Code
AP7383-18Y-13	SOT89	F3A
AP7383-30Y-13	SOT89	F3B
AP7383-33Y-13	SOT89	F3C
AP7383-36Y-13	SOT89	F3D
AP7383-41Y-13	SOT89	F3E
AP7383-44Y-13	SOT89	F3F
AP7383-50Y-13	SOT89	F3G

(3) U-DFN2020-6 (Type C)

(Top View)

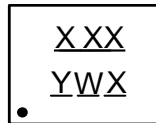

XXX : Identification Code
Y : Year : 0~9
W : Week : A~Z : 1~26 week;
a~z : 27~52 week; z represents
52 and 53 week
X : Internal Code

Part Number	Package	Identification Code
AP7383-18FDC-7	U-DFN2020-6 (Type C)	F3A
AP7383-30FDC-7	U-DFN2020-6 (Type C)	F3B
AP7383-33FDC-7	U-DFN2020-6 (Type C)	F3C
AP7383-36FDC-7	U-DFN2020-6 (Type C)	F3D
AP7383-41FDC-7	U-DFN2020-6 (Type C)	F3E
AP7383-44FDC-7	U-DFN2020-6 (Type C)	F3F
AP7383-50FDC-7	U-DFN2020-6 (Type C)	F3G

Package Outline Dimensions

Please see <http://www.diodes.com/package-outlines.html> for the latest version.

(1) Package Type: SOT89

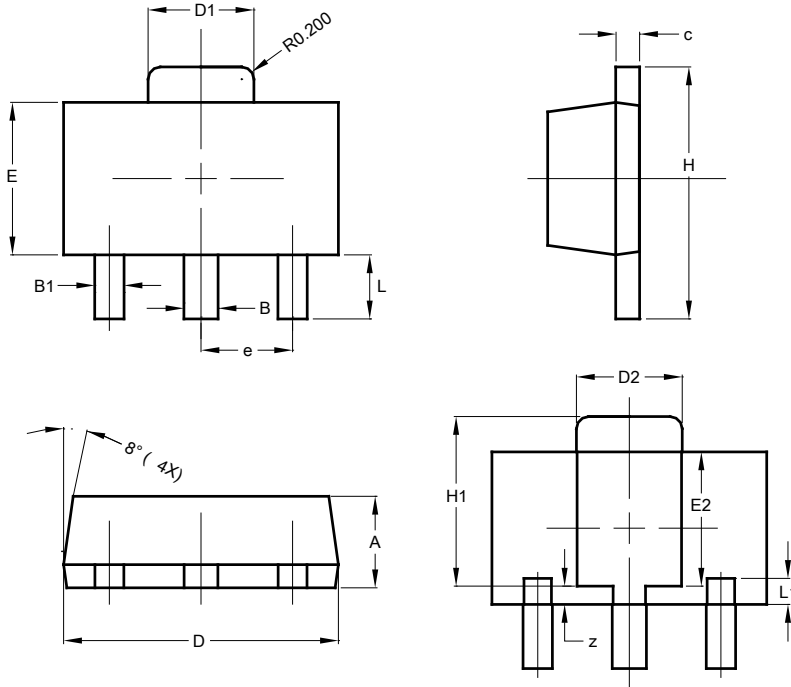

SOT89			
Dim	Min	Max	Typ
A	1.40	1.60	1.50
B	0.50	0.62	0.56
B1	0.42	0.54	0.48
c	0.35	0.43	0.38
D	4.40	4.60	4.50
D1	1.62	1.83	1.733
D2	1.61	1.81	1.71
E	2.40	2.60	2.50
E2	2.05	2.35	2.20
e	—	—	1.50
H	3.95	4.25	4.10
H1	2.63	2.93	2.78
L	0.90	1.20	1.05
L1	0.327	0.527	0.427
z	0.20	0.40	0.30
All Dimensions in mm			

(2) Package Type: SOT25

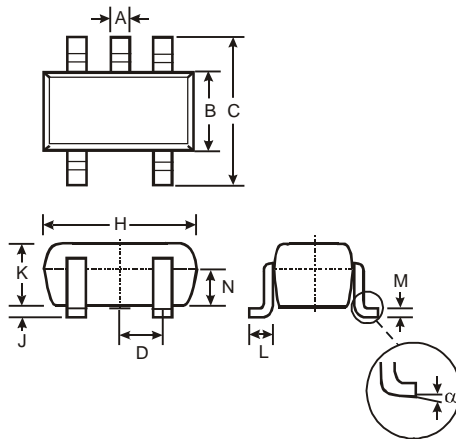

SOT25			
Dim	Min	Max	Typ
A	0.35	0.50	0.38
B	1.50	1.70	1.60
C	2.70	3.00	2.80
D	—	—	0.95
H	2.90	3.10	3.00
J	0.013	0.10	0.05
K	1.00	1.30	1.10
L	0.35	0.55	0.40
M	0.10	0.20	0.15
N	0.70	0.80	0.75
α	0°	8°	—
All Dimensions in mm			

NEW PRODUCT

Package Outline Dimensions (continued)

Please see <http://www.diodes.com/package-outlines.html> for the latest version.

(3) Package Type: U-DFN2020-6 (Type C)

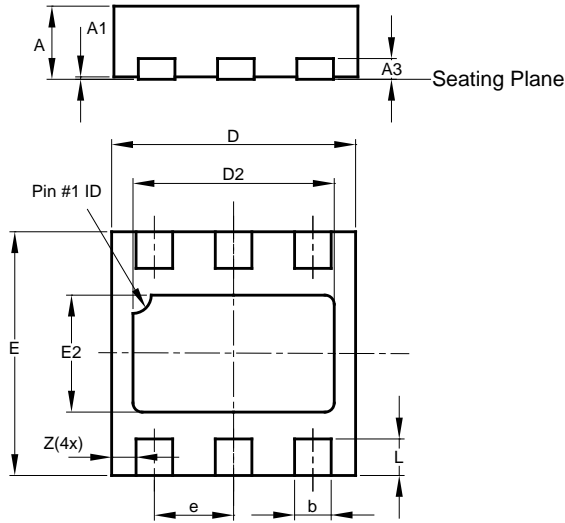

U-DFN2020-6 Type C			
Dim	Min	Max	Typ
A	0.57	0.63	0.60
A1	0.00	0.05	0.02
A3	—	—	0.15
b	0.25	0.35	0.30
D	1.95	2.075	2.00
D2	1.55	1.75	1.65
E	1.95	2.075	2.00
E2	0.86	1.06	0.96
e	—	—	0.65
L	0.25	0.35	0.30
Z	—	—	0.20
All Dimensions in mm			

Suggested Pad Layout

Please see <http://www.diodes.com/package-outlines.html> for the latest version.

(1) Package Type: SOT89

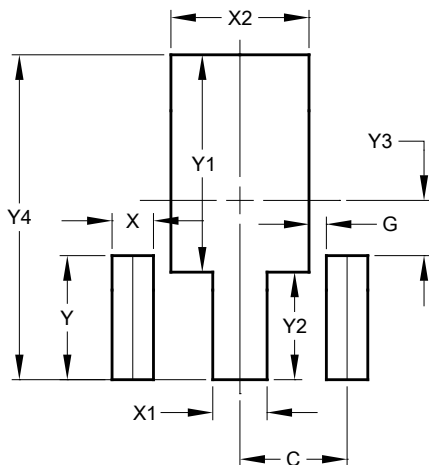

Dimensions	Value (in mm)
C	1.500
G	0.244
X	0.580
X1	0.760
X2	1.933
Y	1.730
Y1	3.030
Y2	1.500
Y3	0.770
Y4	4.530

Suggested Pad Layout (continued)

Please see <http://www.diodes.com/package-outlines.html> for the latest version.

(2) Package Type: SOT25

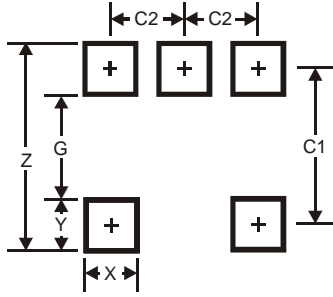

Dimensions	Value
Z	3.20
G	1.60
X	0.55
Y	0.80
C1	2.40
C2	0.95

(3) Package Type: U-DFN2020-6 (Type C)

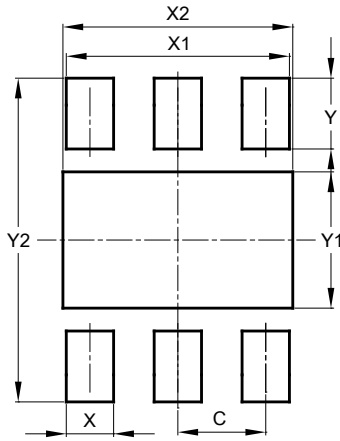

Dimensions	Value (in mm)
C	0.650
X	0.350
X1	1.650
X2	1.700
Y	0.525
Y1	1.010
Y2	2.400

IMPORTANT NOTICE

DIODES INCORPORATED MAKES NO WARRANTY OF ANY KIND, EXPRESS OR IMPLIED, WITH REGARDS TO THIS DOCUMENT, INCLUDING, BUT NOT LIMITED TO, THE IMPLIED WARRANTIES OF MERCHANTABILITY AND FITNESS FOR A PARTICULAR PURPOSE (AND THEIR EQUIVALENTS UNDER THE LAWS OF ANY JURISDICTION).

Diodes Incorporated and its subsidiaries reserve the right to make modifications, enhancements, improvements, corrections or other changes without further notice to this document and any product described herein. Diodes Incorporated does not assume any liability arising out of the application or use of this document or any product described herein; neither does Diodes Incorporated convey any license under its patent or trademark rights, nor the rights of others. Any Customer or user of this document or products described herein in such applications shall assume all risks of such use and will agree to hold Diodes Incorporated and all the companies whose products are represented on Diodes Incorporated website, harmless against all damages.

Diodes Incorporated does not warrant or accept any liability whatsoever in respect of any products purchased through unauthorized sales channel. Should Customers purchase or use Diodes Incorporated products for any unintended or unauthorized application, Customers shall indemnify and hold Diodes Incorporated and its representatives harmless against all claims, damages, expenses, and attorney fees arising out of, directly or indirectly, any claim of personal injury or death associated with such unintended or unauthorized application.

Products described herein may be covered by one or more United States, international or foreign patents pending. Product names and markings noted herein may also be covered by one or more United States, international or foreign trademarks.

This document is written in English but may be translated into multiple languages for reference. Only the English version of this document is the final and determinative format released by Diodes Incorporated.

LIFE SUPPORT

Diodes Incorporated products are specifically not authorized for use as critical components in life support devices or systems without the express written approval of the Chief Executive Officer of Diodes Incorporated. As used herein:

A. Life support devices or systems are devices or systems which:

1. are intended to implant into the body, or
2. support or sustain life and whose failure to perform when properly used in accordance with instructions for use provided in the labeling can be reasonably expected to result in significant injury to the user.

B. A critical component is any component in a life support device or system whose failure to perform can be reasonably expected to cause the failure of the life support device or to affect its safety or effectiveness.

Customers represent that they have all necessary expertise in the safety and regulatory ramifications of their life support devices or systems, and acknowledge and agree that they are solely responsible for all legal, regulatory and safety-related requirements concerning their products and any use of Diodes Incorporated products in such safety-critical, life support devices or systems, notwithstanding any devices- or systems-related information or support that may be provided by Diodes Incorporated. Further, Customers must fully indemnify Diodes Incorporated and its representatives against any damages arising out of the use of Diodes Incorporated products in such safety-critical, life support devices or systems.

Copyright © 2020, Diodes Incorporated

www.diodes.com

X-ON Electronics

Largest Supplier of Electrical and Electronic Components

Click to view similar products for [LDO Voltage Regulators](#) category:

Click to view products by [Diodes Incorporated](#) manufacturer:

Other Similar products are found below :

[AP7363-SP-13](#) [L79M05TL-E](#) [AP7362-HA-7](#) [PT7M8202B12TA5EX](#) [TCR3DF185,LM\(CT](#) [TCR3DF45,LM\(CT](#) [TLE4473G V52](#)
[NCP4687DH15T1G](#) [701326R](#) [AP7315-25W5-7](#) [AP2111H-1.2TRG1](#) [ZLDO1117QK50TC](#) [AZ1117ID-ADJTRG1](#) [TCR3DG12,LF](#) [MIC5514-](#)
[3.3YMT-T5](#) [SCD7912BTG](#) [NCP154MX180270TAG](#) [SCD33269T-5.0G](#) [NCP706ABMX300TAG](#) [NCP114BMX075TCG](#) [MC33269T-3.5G](#)
[TCR3DG33,LF](#) [TLE4471GXT](#) [TCR4DG35,LF](#) [TAR5S15U\(TE85L,F\)](#) [TCR3UG19A,LF](#) [TCR4DG105,LF](#) [MPQ2013AGG-5-P](#) [AP7315-](#)
[33SA-7](#) [TLE4268GSXUMA2](#) [NCP715SQ15T2G](#) [MIC5317-3.0YD5-T5](#) [NCV563SQ18T1G](#) [NCP715MX30TBG](#) [NCV8702MX25TCG](#)
[MIC5317-1.2YD5-T5](#) [AP2213D-3.3TRG1](#) [MIC5514-1.2YMT-T5](#) [NCV8170BMX280TCG](#) [AP2202K-2.6TRE1](#) [NCV8170AXV120T2G](#)
[NCV8170BMX300TCG](#) [NCV8152MX300180TCG](#) [NCP700CMT45TBG](#) [AP7315-33W5-7](#) [NCP154MX180300TAG](#) [TCR2DG13,LF](#)
[AP2113AMTR-G1](#) [TCR15AG12,LF](#) [TAR5S16U\(TE85L,F\)](#)