

**3A LOW DROPOUT LINEAR REGULATOR**
**AZ1085**
**General Description**

The AZ1085 is a series of low dropout positive voltage regulators with a maximum dropout of 1.5V at 3A of load current.

The series features on-chip thermal shutdown. It also includes a bandgap reference and a current limiting circuit.

The AZ1085 is available in 1.5V, 1.8V, 2.5V, 3.3V, 5.0V and adjustable versions. The fixed versions integrate the adjust resistors. The adjustable version can set the output voltage with two external resistors.

The AZ1085 series is available in standard packages of TO-263-2, TO-263-3, TO-220-3, TO-252-2 (1), TO-252-2 (2), TO-252-2 (3) and TO-252-2 (4).

**Features**

- Low Dropout Voltage: Typical 1.3V at 3A
- Current Limiting and Thermal Protection
- Output Current: 3A
- Current Limit: 4.5A
- Operating Junction Temperature: 0 to 125°C
- Line Regulation: 0.015% (Typical)
- Load Regulation: 0.1% (Typical)

**Applications**

- High Efficiency Linear Regulators
- Battery Charger
- Post Regulation for Switching Supplies
- Microprocessor Supply
- Mother Board Power Supplies
- DVD-Video Player
- Telecom Equipment
- Set Top boxes and Web Boxes Modules' Supply

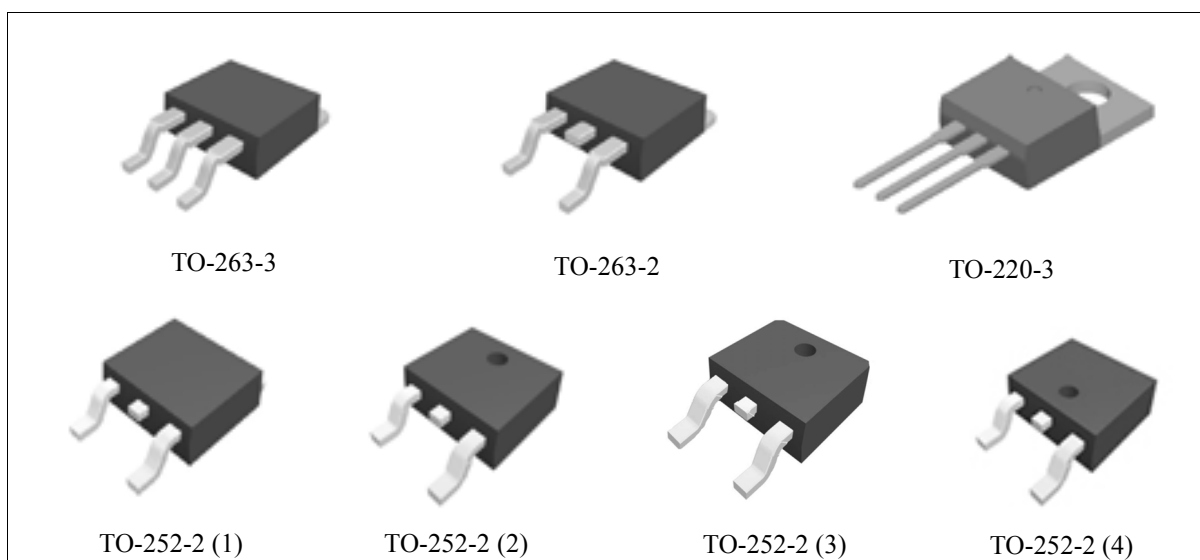

Figure 1. Package Types of AZ1085

**3A LOW DROPOUT LINEAR REGULATOR**

**AZ1085**

**Pin Configuration**

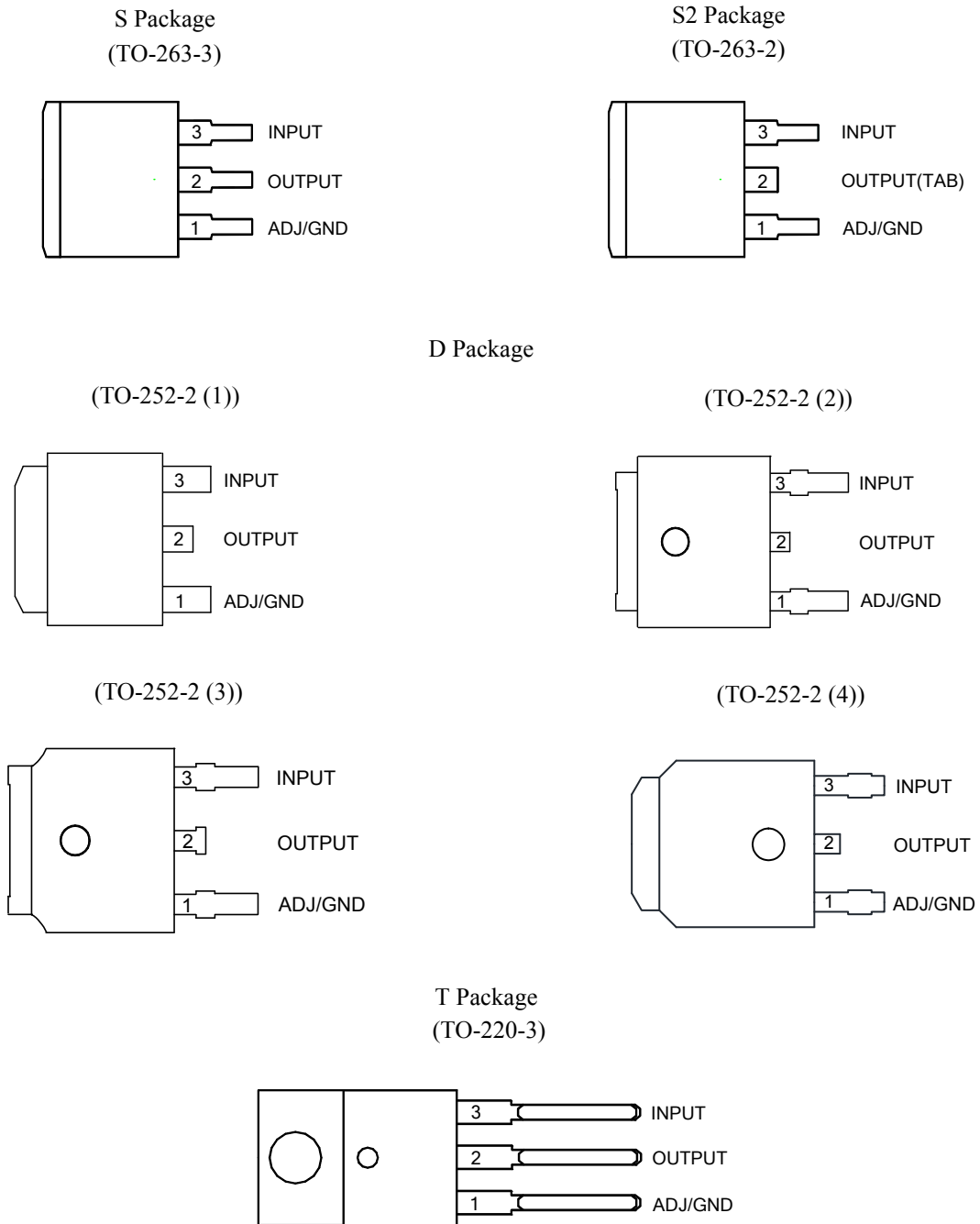

Figure 2. Pin Configuration of AZ1085 (Top View)

**3A LOW DROPOUT LINEAR REGULATOR**

**AZ1085**

**Functional Block Diagram**

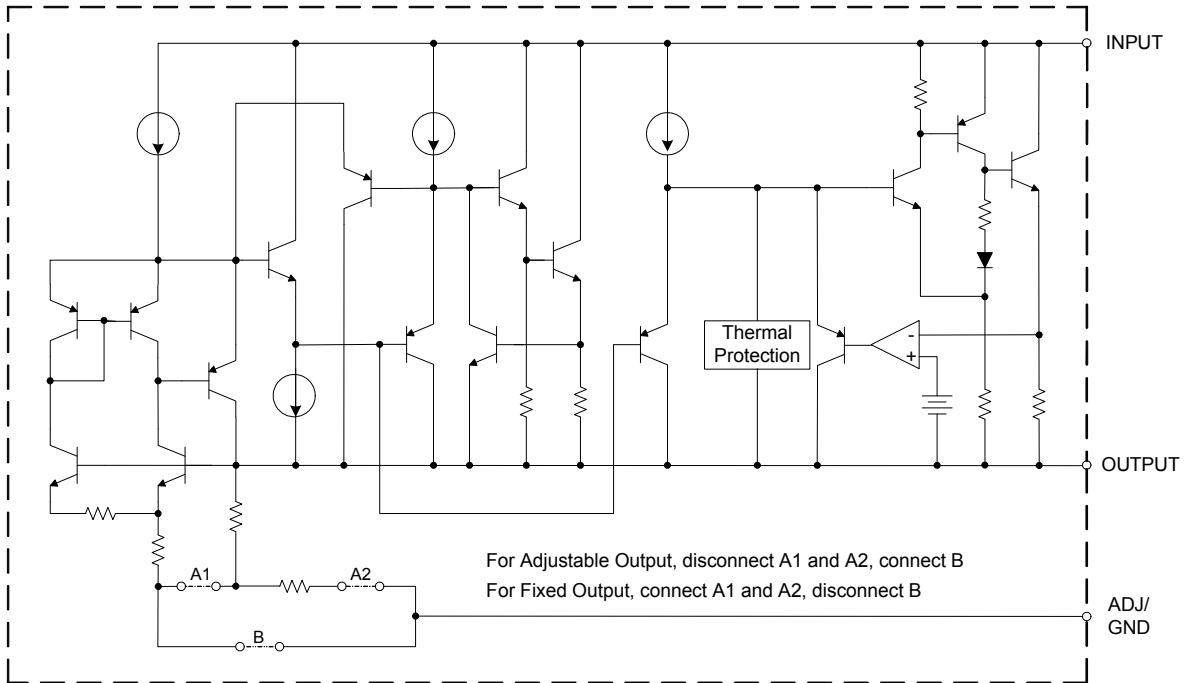

Figure 3. Functional Block Diagram of AZ1085



**3A LOW DROPOUT LINEAR REGULATOR**

**AZ1085**

**Ordering Information**

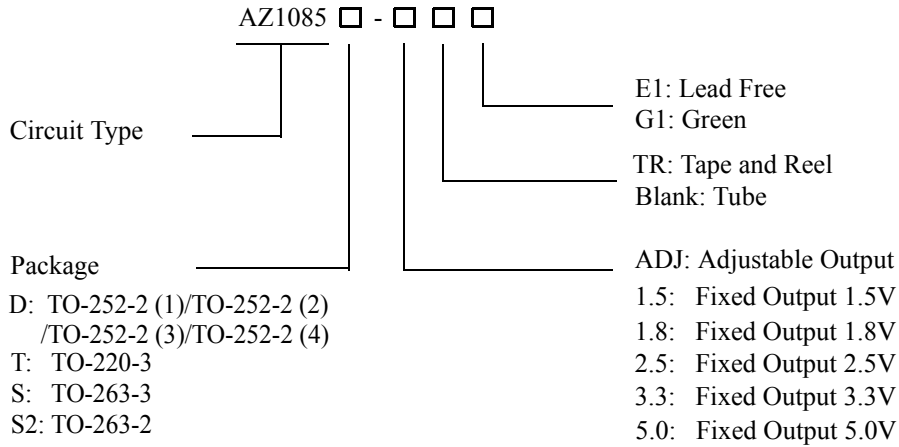

Package	Temperature Range	Part Number		Marking ID		Packing Type
		Lead Free	Green	Lead Free	Green	
TO-252-2 (1)/ TO-252-2 (2)/ TO-252-2 (3)/ TO-252-2 (4)	0 to 125°C	AZ1085D-ADJE1	AZ1085D-ADJG1	AZ1085D-ADJE1	AZ1085D-ADJG1	Tube
		AZ1085D-ADJTRE1	AZ1085D-ADJTRG1	AZ1085D-ADJE1	AZ1085D-ADJG1	Tape & Reel
		AZ1085D-1.5E1	AZ1085D-1.5G1	AZ1085D-1.5E1	AZ1085D-1.5G1	Tube
		AZ1085D-1.5TRE1	AZ1085D-1.5TRG1	AZ1085D-1.5E1	AZ1085D-1.5G1	Tape & Reel
		AZ1085D-1.8E1	AZ1085D-1.8G1	AZ1085D-1.8E1	AZ1085D-1.8G1	Tube
		AZ1085D-1.8TRE1	AZ1085D-1.8TRG1	AZ1085D-1.8E1	AZ1085D-1.8G1	Tape & Reel
		AZ1085D-2.5E1	AZ1085D-2.5G1	AZ1085D-2.5E1	AZ1085D-2.5G1	Tube
		AZ1085D-2.5TRE1	AZ1085D-2.5TRG1	AZ1085D-2.5E1	AZ1085D-2.5G1	Tape & Reel
		AZ1085D-3.3E1	AZ1085D-3.3G1	AZ1085D-3.3E1	AZ1085D-3.3G1	Tube
		AZ1085D-3.3TRE1	AZ1085D-3.3TRG1	AZ1085D-3.3E1	AZ1085D-3.3G1	Tape & Reel
		AZ1085D-5.0E1	AZ1085D-5.0G1	AZ1085D-5.0E1	AZ1085D-5.0G1	Tube
		AZ1085D-5.0TRE1	AZ1085D-5.0TRG1	AZ1085D-5.0E1	AZ1085D-5.0G1	Tape & Reel
TO-220-3	0 to 125°C	AZ1085T-ADJE1	AZ1085T-ADJG1	AZ1085T-ADJE1	AZ1085T-ADJG1	Tube
		AZ1085T-1.5E1	AZ1085T-1.5G1	AZ1085T-1.5E1	AZ1085T-1.5G1	Tube
		AZ1085T-1.8E1	AZ1085T-1.8G1	AZ1085T-1.8E1	AZ1085T-1.8G1	Tube
		AZ1085T-2.5E1	AZ1085T-2.5G1	AZ1085T-2.5E1	AZ1085T-2.5G1	Tube
		AZ1085T-3.3E1	AZ1085T-3.3G1	AZ1085T-3.3E1	AZ1085T-3.3G1	Tube
		AZ1085T-5.0E1	AZ1085T-5.0G1	AZ1085T-5.0E1	AZ1085T-5.0G1	Tube



**3A LOW DROPOUT LINEAR REGULATOR**

**AZ1085**

**Ordering Information (Continued)**

Package	Temperature Range	Part Number		Marking ID		Packing Type
		Lead Free	Green	Lead Free	Green	
TO-263-3	0 to 125°C	AZ1085S-ADJE1	AZ1085S-ADJG1	AZ1085S-ADJE1	AZ1085S-ADJG1	Tube
		AZ1085S-ADJTRE1	AZ1085S-ADJTRG1	AZ1085S-ADJE1	AZ1085S-ADJG1	Tape & Reel
		AZ1085S-1.5E1	AZ1085S-1.5G1	AZ1085S-1.5E1	AZ1085S-1.5G1	Tube
		AZ1085S-1.5TRE1	AZ1085S-1.5TRG1	AZ1085S-1.5E1	AZ1085S-1.5G1	Tape & Reel
		AZ1085S-1.8E1	AZ1085S-1.8G1	AZ1085S-1.8E1	AZ1085S-1.8G1	Tube
		AZ1085S-1.8TRE1	AZ1085S-1.8TRG1	AZ1085S-1.8E1	AZ1085S-1.8G1	Tape & Reel
		AZ1085S-2.5E1	AZ1085S-2.5G1	AZ1085S-2.5E1	AZ1085S-2.5G1	Tube
		AZ1085S-2.5TRE1	AZ1085S-2.5TRG1	AZ1085S-2.5E1	AZ1085S-2.5G1	Tape & Reel
		AZ1085S-3.3E1	AZ1085S-3.3G1	AZ1085S-3.3E1	AZ1085S-3.3G1	Tube
		AZ1085S-3.3TRE1	AZ1085S-3.3TRG1	AZ1085S-3.3E1	AZ1085S-3.3G1	Tape & Reel
		AZ1085S-5.0E1	AZ1085S-5.0G1	AZ1085S-5.0E1	AZ1085S-5.0G1	Tube
		AZ1085S-5.0TRE1	AZ1085S-5.0TRG1	AZ1085S-5.0E1	AZ1085S-5.0G1	Tape & Reel
TO-263-2	0 to 125°C	AZ1085S2-ADJE1	AZ1085S2-ADJG1	AZ1085S2-ADJE1	AZ1085S2-ADJG1	Tube
		AZ1085S2-ADJTRE1	AZ1085S2-ADJTRG1	AZ1085S2-ADJE1	AZ1085S2-ADJG1	Tape & Reel
		AZ1085S2-1.5E1	AZ1085S2-1.5G1	AZ1085S2-1.5E1	AZ1085S2-1.5G1	Tube
		AZ1085S2-1.5TRE1	AZ1085S2-1.5TRG1	AZ1085S2-1.5E1	AZ1085S2-1.5G1	Tape & Reel
		AZ1085S2-1.8E1	AZ1085S2-1.8G1	AZ1085S2-1.8E1	AZ1085S2-1.8G1	Tube
		AZ1085S2-1.8TRE1	AZ1085S2-1.8TRG1	AZ1085S2-1.8E1	AZ1085S2-1.8G1	Tape & Reel
		AZ1085S2-2.5E1	AZ1085S2-2.5G1	AZ1085S2-2.5E1	AZ1085S2-2.5G1	Tube
		AZ1085S2-2.5TRE1	AZ1085S2-2.5TRG1	AZ1085S2-2.5E1	AZ1085S2-2.5G1	Tape & Reel
		AZ1085S2-3.3E1	AZ1085S2-3.3G1	AZ1085S2-3.3E1	AZ1085S2-3.3G1	Tube
		AZ1085S2-3.3TRE1	AZ1085S2-3.3TRG1	AZ1085S2-3.3E1	AZ1085S2-3.3G1	Tape & Reel
		AZ1085S2-5.0E1	AZ1085S2-5.0G1	AZ1085S2-5.0E1	AZ1085S2-5.0G1	Tube
		AZ1085S2-5.0TRE1	AZ1085S2-5.0TRG1	AZ1085S2-5.0E1	AZ1085S2-5.0G1	Tape & Reel

BCD Semiconductor's Pb-free products, as designated with "E1" suffix in the part number, are RoHS compliant. Products with "G1" suffix are available in green packages.

**3A LOW DROPOUT LINEAR REGULATOR****AZ1085****Absolute Maximum Ratings (Note 1)**

Parameter	Symbol	Value		Unit
Operating Junction Temperature	$T_J$	150		°C
Storage Temperature Range	$T_{STG}$	-65 to 150		°C
Lead Temperature (Soldering, 10sec)	$T_{LEAD}$	260		°C
Thermal Resistance(Note 2)	$\theta_{JA}$	TO-220-3	60	°C/W
		TO-263-2	60	
		TO-263-3	60	
		TO-252-2 (1)/TO-252-2 (2)/ TO-252-2 (3)/TO-252-2 (4)	100	
ESD (Human Body Model)	ESD	2000		V

Note 1: Stresses greater than those listed under "Absolute Maximum Ratings" may cause permanent damage to the device. These are stress ratings only, and functional operation of the device at these or any other conditions beyond those indicated under "Recommended Operating Conditions" is not implied. Exposure to "Absolute Maximum Ratings" for extended periods may affect device reliability.

Note 2: Absolute maximum ratings indicate limits beyond which damage to the component may occur. Electrical specifications do not apply when operating the device outside of its operating ratings. The maximum allowable power dissipation is a function of the maximum junction temperature,  $T_{J(max)}$ , the junction-to-ambient thermal resistance,  $\theta_{JA}$ , and the ambient temperature,  $T_A$ . The maximum allowable power dissipation at any ambient temperature is calculated using:  $P_{D(max)} = (T_{J(max)} - T_A) / \theta_{JA}$ . Exceeding the maximum allowable power dissipation will result in excessive die temperature, and the regulator will go into thermal shutdown.

**Recommended Operating Conditions**

Parameter	Symbol	Min	Max	Unit
Input Voltage	$V_{IN}$		12	V
Operating Junction Temperature Range	$T_J$	0	125	°C



**3A LOW DROPOUT LINEAR REGULATOR**

**AZ1085**

**Electrical Characteristics**

Typicals and limits appearing in normal type apply for  $T_J=25^{\circ}\text{C}$ . Limits appearing in **Boldface** type apply over the entire operating junction temperature range 0 to  $125^{\circ}\text{C}$ .

Parameter	Symbol	Conditions	Min	Typ	Max	Unit
Reference Voltage	$V_{REF}$	AZ1085-ADJ, $I_{OUT}=10\text{mA}$ , $V_{IN}-V_{OUT}=3\text{V}$ , $T_J=25^{\circ}\text{C}$ , $10\text{mA} \leq I_{OUT} \leq 3\text{A}$ , $1.5\text{V} \leq V_{IN}-V_{OUT} \leq 5\text{V}$	1.238 <b>1.225</b>	1.250 <b>1.250</b>	1.262 <b>1.275</b>	V
Output Voltage	$V_{OUT}$	AZ1085-1.5, $I_{OUT}=0\text{mA}$ , $V_{IN}=4.5\text{V}$ , $T_J=25^{\circ}\text{C}$ , $10\text{mA} \leq I_{OUT} \leq 3\text{A}$ , $3.0\text{V} \leq V_{IN} \leq 6\text{V}$	1.485 <b>1.47</b>	1.5 <b>1.5</b>	1.515 <b>1.53</b>	V
		AZ1085-1.8, $I_{OUT}=0\text{mA}$ , $V_{IN}=4.8\text{V}$ , $T_J=25^{\circ}\text{C}$ , $10\text{mA} \leq I_{OUT} \leq 3\text{A}$ , $3.3\text{V} \leq V_{IN} \leq 7\text{V}$	1.782 <b>1.764</b>	1.8 <b>1.8</b>	1.818 <b>1.836</b>	V
		AZ1085-2.5, $I_{OUT}=0\text{mA}$ , $V_{IN}=5.5\text{V}$ , $T_J=25^{\circ}\text{C}$ , $10\text{mA} \leq I_{OUT} \leq 3\text{A}$ , $4.0\text{V} \leq V_{IN} \leq 7\text{V}$	2.475 <b>2.45</b>	2.5 <b>2.5</b>	2.525 <b>2.55</b>	V
		AZ1085-3.3, $I_{OUT}=0\text{mA}$ , $V_{IN}=6.3\text{V}$ , $T_J=25^{\circ}\text{C}$ , $10\text{mA} \leq I_{OUT} \leq 3\text{A}$ , $4.8\text{V} \leq V_{IN} \leq 8\text{V}$	3.267 <b>3.234</b>	3.3 <b>3.3</b>	3.333 <b>3.366</b>	V
		AZ1085-5.0, $I_{OUT}=0\text{mA}$ , $V_{IN}=8\text{V}$ , $T_J=25^{\circ}\text{C}$ , $10\text{mA} \leq I_{OUT} \leq 3\text{A}$ , $6.5\text{V} \leq V_{IN} \leq 10\text{V}$	4.95 <b>4.9</b>	5 <b>5</b>	5.05 <b>5.1</b>	V
Line Regulation	$\Delta V_{OUT}$	AZ1085-ADJ, $I_{OUT}=10\text{mA}$ , $2.85\text{V} \leq V_{IN} \leq 10\text{V}$		0.015 <b>0.035</b>	0.2 <b>0.2</b>	%
		AZ1085-1.5, $I_{OUT}=10\text{mA}$ , $3.0\text{V} \leq V_{IN} \leq 10\text{V}$		0.5 <b>1</b>	6 <b>6</b>	mV
		AZ1085-1.8, $I_{OUT}=10\text{mA}$ , $3.3\text{V} \leq V_{IN} \leq 10\text{V}$		0.5 <b>1</b>	6 <b>6</b>	mV
		AZ1085-2.5, $I_{OUT}=10\text{mA}$ , $4.0\text{V} \leq V_{IN} \leq 10\text{V}$		0.5 <b>1</b>	6 <b>6</b>	mV
		AZ1085-3.3, $I_{OUT}=10\text{mA}$ , $4.8\text{V} \leq V_{IN} \leq 10\text{V}$		0.5 <b>1</b>	6 <b>6</b>	mV
		AZ1085-5.0, $I_{OUT}=10\text{mA}$ , $6.5\text{V} \leq V_{IN} \leq 10\text{V}$		0.5 <b>1</b>	10 <b>10</b>	mV



**3A LOW DROPOUT LINEAR REGULATOR**

**AZ1085**

**Electrical Characteristics (Continued)**

Typicals and limits appearing in normal type apply for  $T_J=25^{\circ}\text{C}$ . Limits appearing in **Boldface** type apply over the entire operating junction temperature range 0 to  $125^{\circ}\text{C}$ .

Parameter	Symbol	Conditions	Min	Typ	Max	Unit
Load Regulation	$\Delta V_{OUT}$	AZ1085-ADJ, $0\text{mA} \leq I_{OUT} \leq 3\text{A}$ , $V_{IN} - V_{OUT} = 3\text{V}$		0.1 <b>0.2</b>	0.3 <b>0.4</b>	%
		AZ1085-1.5, $0\text{mA} \leq I_{OUT} \leq 3\text{A}$ , $V_{IN} - V_{OUT} = 3\text{V}$		3 7	15 <b>20</b>	mV
		AZ1085-1.8, $0\text{mA} \leq I_{OUT} \leq 3\text{A}$ , $V_{IN} - V_{OUT} = 3\text{V}$		3 7	15 <b>20</b>	mV
		AZ1085-2.5, $0\text{mA} \leq I_{OUT} \leq 3\text{A}$ , $V_{IN} - V_{OUT} = 3\text{V}$		3 7	15 <b>20</b>	mV
		AZ1085-3.3, $0\text{mA} \leq I_{OUT} \leq 3\text{A}$ , $V_{IN} - V_{OUT} = 3\text{V}$		3 7	15 <b>20</b>	mV
		AZ1085-5.0, $0\text{mA} \leq I_{OUT} \leq 3\text{A}$ , $V_{IN} - V_{OUT} = 3\text{V}$			5 <b>10</b>	20 <b>35</b>
Dropout Voltage	$V_{DROP}$	$I_{OUT} = 3\text{A}$ , $\Delta V_{REF}$ , $\Delta V_{OUT} = 1\%$		<b>1.3</b>	<b>1.5</b>	V
Thermal Resistance	$\theta_{JC}$	TO-220-3		4.15		$^{\circ}\text{C}/\text{W}$
		TO-252-2 (1)/TO-252-2 (2)/TO-252-2 (3)/ TO-252-2 (4)		7.36		
		TO-263-3		4.15		
		TO-263-2		4.15		
Current Limit	$I_{LIMIT}$	$V_{IN} - V_{OUT} = 3\text{V}$	3.2	4.5		A
Minimum Load Current	$I_{LOAD}$ (MIN)	$V_{IN} = 10\text{V}$ (AZ1085-ADJ)		<b>3</b>	<b>10</b>	mA
Quiescent Current	$I_Q$	$V_{IN} = 10\text{V}$ (AZ1085)		<b>5</b>	<b>10</b>	mA
Ripple Rejection	PSRR	$f_{RIPPLE} = 120\text{Hz}$ , $C_{OUT} = 25\mu\text{F}$ , $I_{OUT} = 3\text{A}$ , $V_{IN} - V_{OUT} = 3\text{V}$	<b>60</b>	<b>72</b>		dB
Adjust Pin Current	$I_{ADJ}$	$V_{IN} = 4.25\text{V}$ , $I_{OUT} = 10\text{mA}$		55	<b>120</b>	$\mu\text{A}$
Adjust Pin Current Change	$\Delta I_{ADJ}$	$10\text{mA} \leq I_{OUT} \leq 3\text{A}$ , $1.5\text{V} \leq V_{IN} - V_{OUT} \leq 6\text{V}$		<b>0.2</b>	<b>5</b>	$\mu\text{A}$
Long Term Stability		$T_A = 125^{\circ}\text{C}$ , 1000Hrs		0.5		%
Temperature Stability		$I_{OUT} = 10\text{mA}$ , $V_{IN} - V_{OUT} = 1.5\text{V}$		<b>0.5</b>		%
RMS Noise (% of $V_{OUT}$ )		$T_A = 25^{\circ}\text{C}$ , $10\text{Hz} \leq f \leq 10\text{kHz}$		0.003		%





**3A LOW DROPOUT LINEAR REGULATOR**

**AZ1085**

**Typical Performance Characteristics**

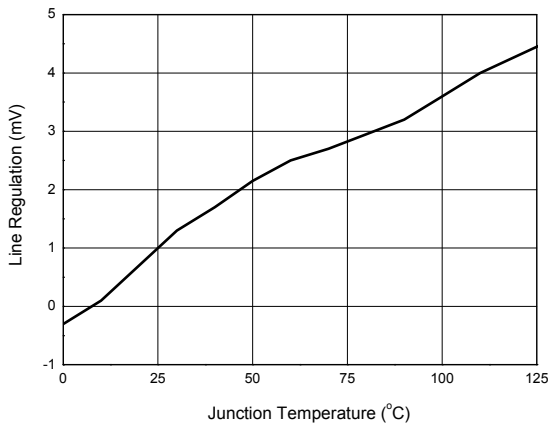

Figure 4. Line Regulation vs. Junction Temperature

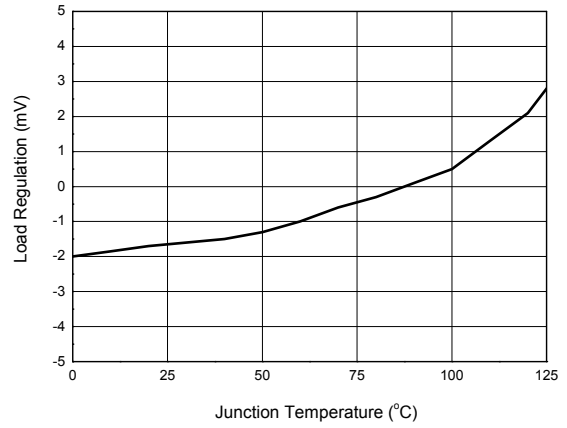

Figure 5. Load Regulation vs. Junction Temperature

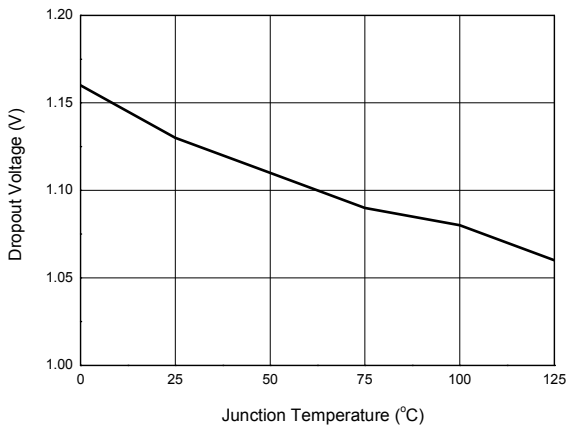

Figure 6. Dropout Voltage vs. Junction Temperature

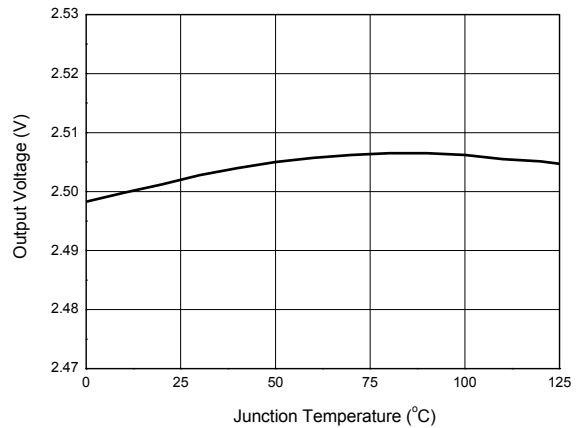

Figure 7. Output Voltage vs. Junction Temperature



**3A LOW DROPOUT LINEAR REGULATOR**

**AZ1085**

**Typical Performance Characteristics (Continued)**

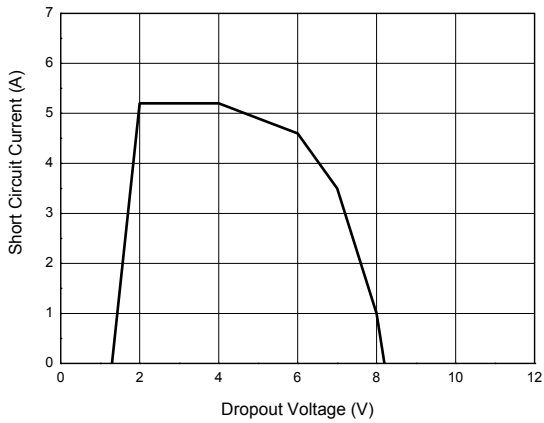

Figure 8. Short Circuit Current vs. Dropout Voltage

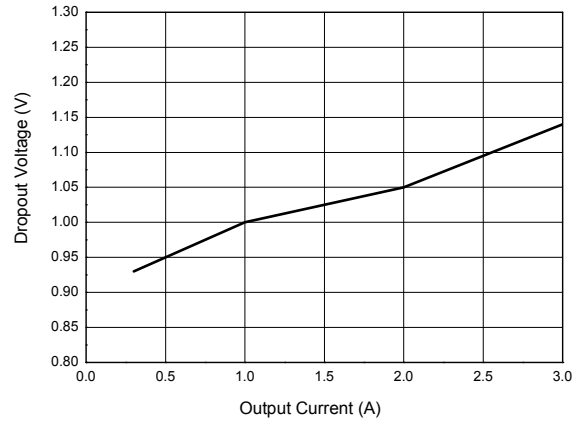

Figure 9. Dropout Voltage vs. Output Current

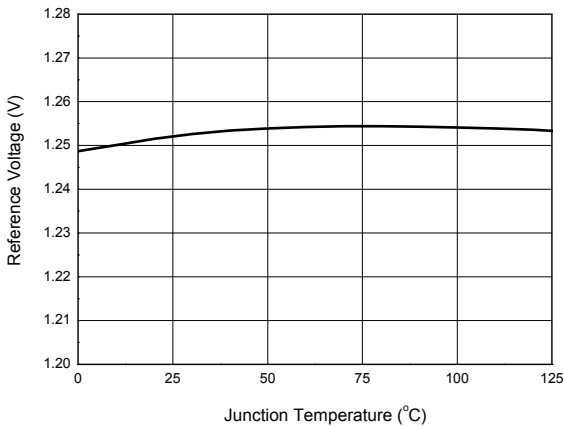

Figure 10. Reference Voltage vs. Junction Temperature

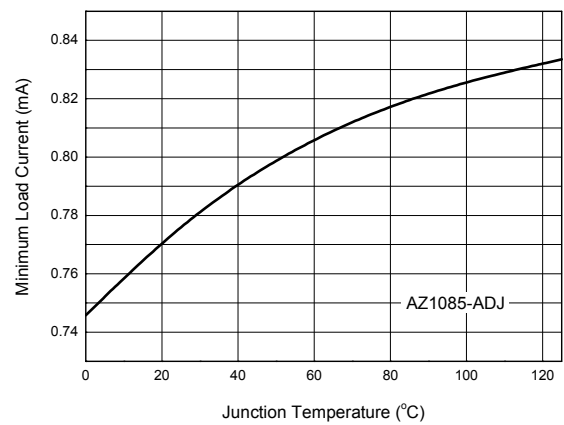

Figure 11. Minimum Load Current vs. Junction Temperature



**3A LOW DROPOUT LINEAR REGULATOR**

**AZ1085**

**Typical Performance Characteristics (Continued)**

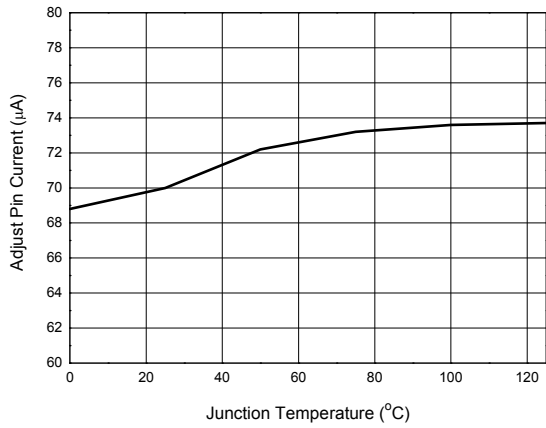

Figure12. Adjust Pin Current vs. Junction Temperature

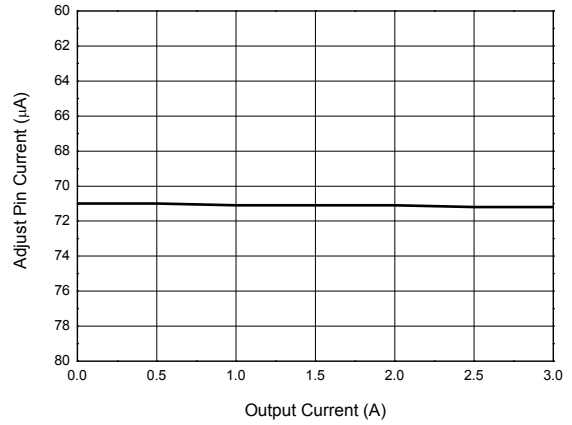

Figure13. Adjust Pin Current vs. Output Current

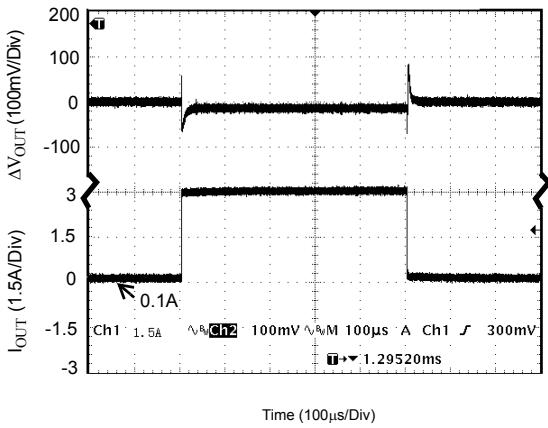

Figure 14. Load Transient Response  
(Conditions:  $V_{IN}=5.5V$ ,  $V_{OUT}=2.5V$ ,  $I_{OUT}=100mA$  to  $3A$ ,  
 $C_{IN}=C_{OUT}=10\mu F$ )

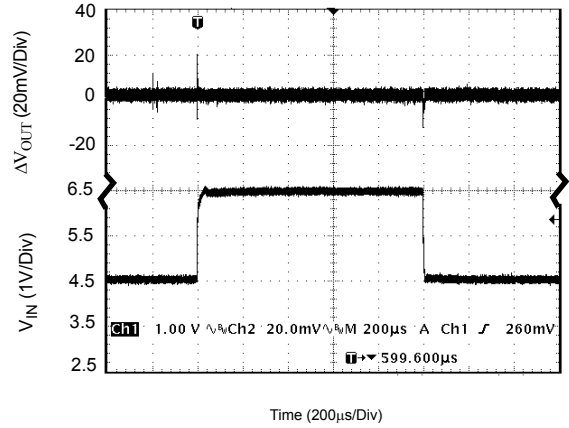

Figure 15. Line Transient Response  
(Conditions:  $V_{IN}=4.5V$  to  $6.5V$ ,  $V_{OUT}=2.5V$ ,  
 $I_{OUT}=200mA$ ,  $C_{IN}=1\mu F$ ,  $C_{OUT}=10\mu F$ )



**3A LOW DROPOUT LINEAR REGULATOR**

**AZ1085**

**Typical Performance Characteristics (Continued)**

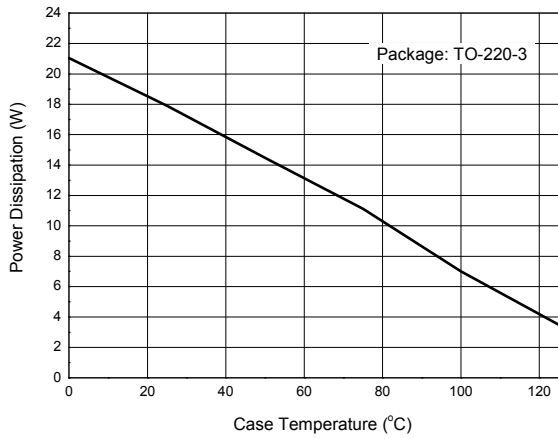

Figure16. Power Dissipation vs. Case Temperature

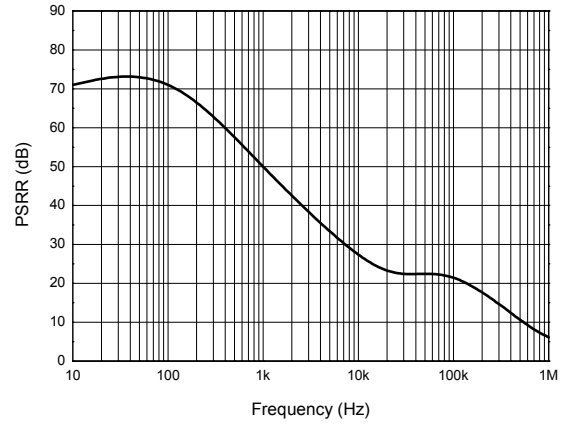

Figure17. PSRR vs. Frequency

**Typical Application**

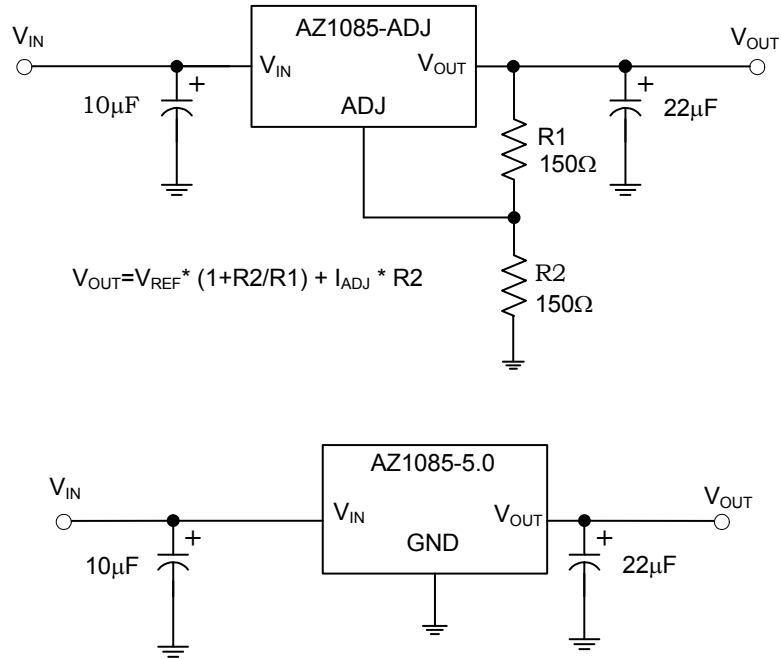

Figure 18. Typical Applications of AZ1085



**3A LOW DROPOUT LINEAR REGULATOR**

**AZ1085**

**Mechanical Dimensions**

**TO-220-3**

**Unit: mm(inch)**

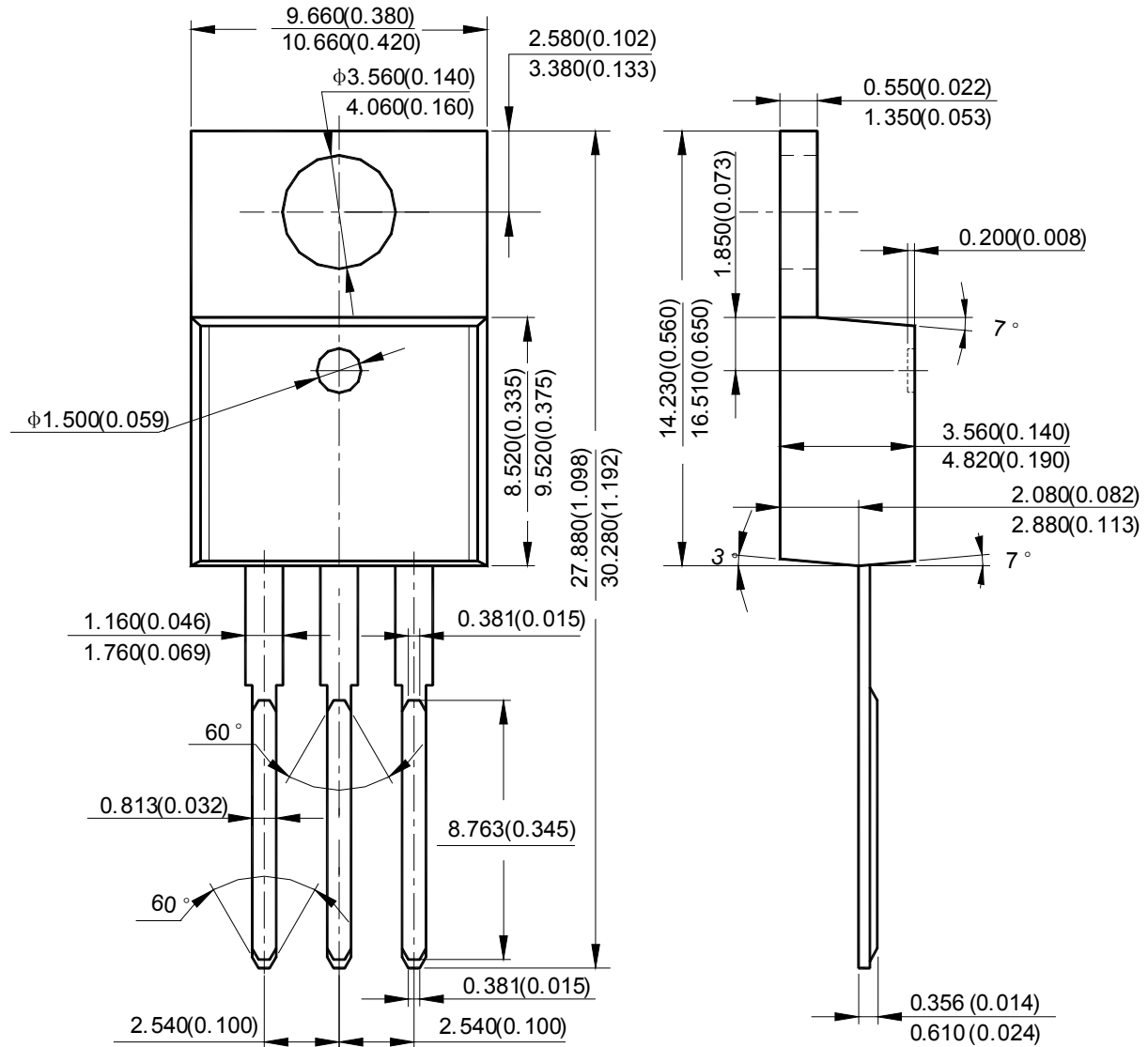

**3A LOW DROPOUT LINEAR REGULATOR**

**AZ1085**

**Mechanical Dimensions (Continued)**

**TO-263-3**

**Unit: mm(inch)**

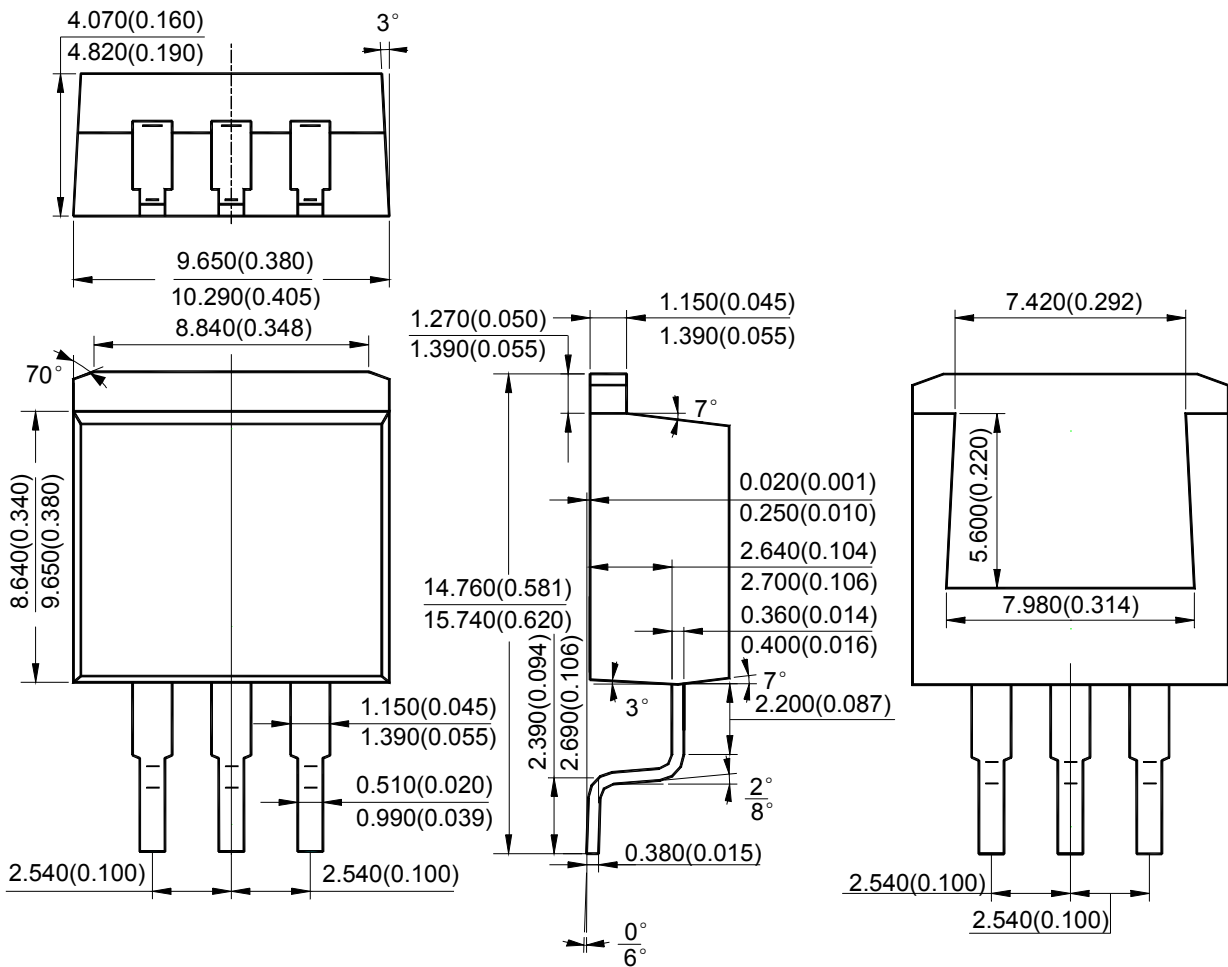



**3A LOW DROPOUT LINEAR REGULATOR**

**AZ1085**

**Mechanical Dimensions (Continued)**

**TO-263-2**

**Unit: mm(inch)**

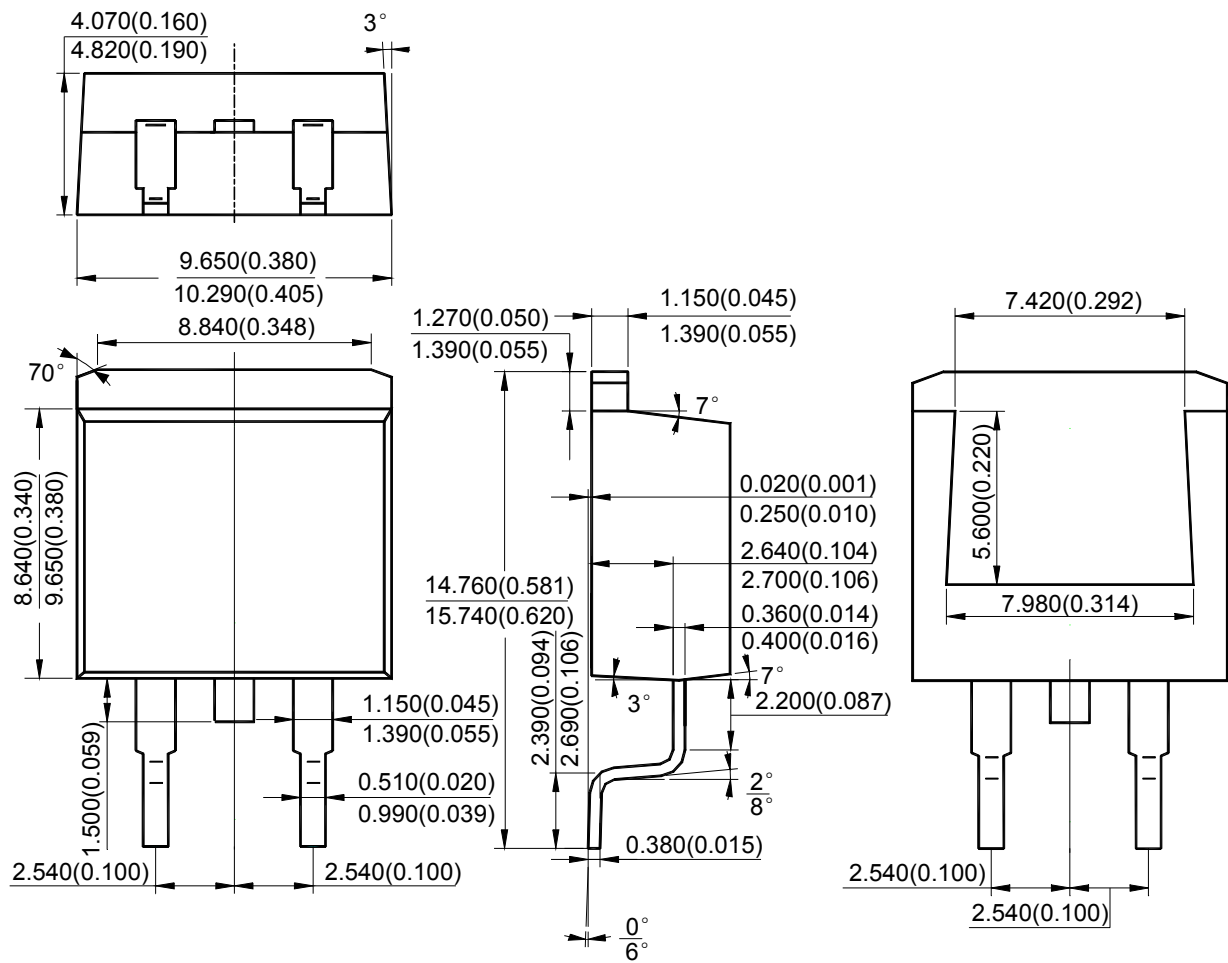





**3A LOW DROPOUT LINEAR REGULATOR**

**AZ1085**

**Mechanical Dimensions (Continued)**

**TO-252-2 (1)**

**Unit: mm(inch)**

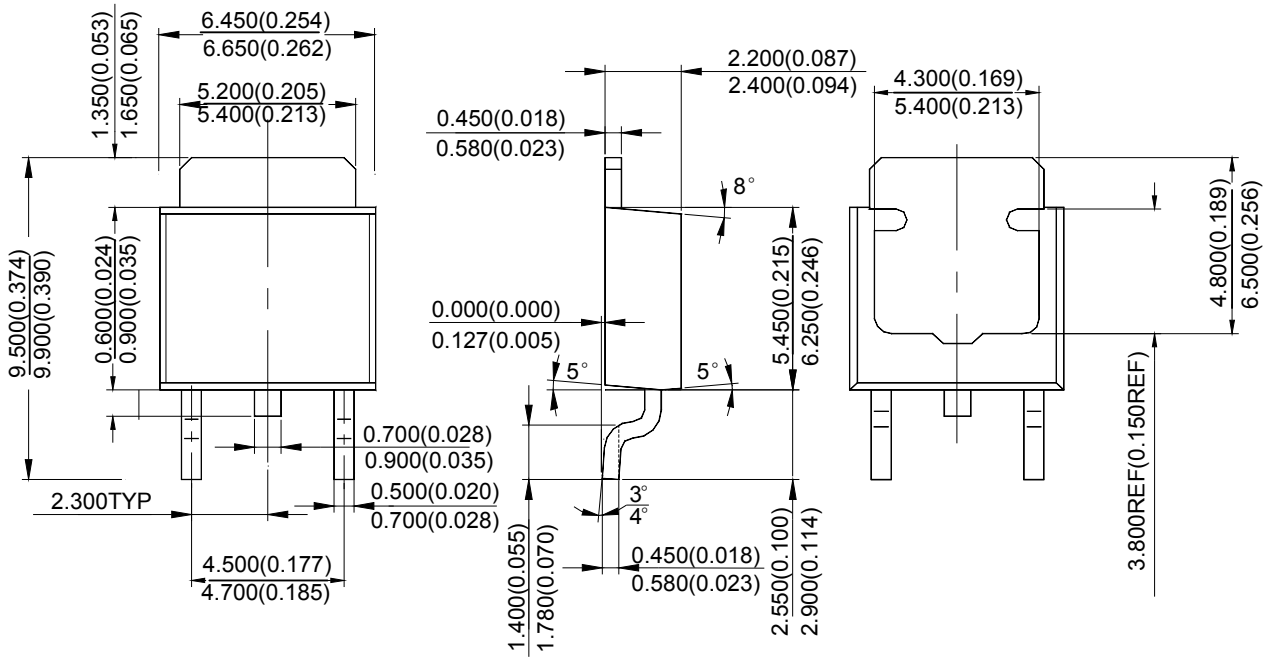



**3A LOW DROPOUT LINEAR REGULATOR**

**AZ1085**

**Mechanical Dimensions (Continued)**

**TO-252-2 (2)**

**Unit: mm(inch)**

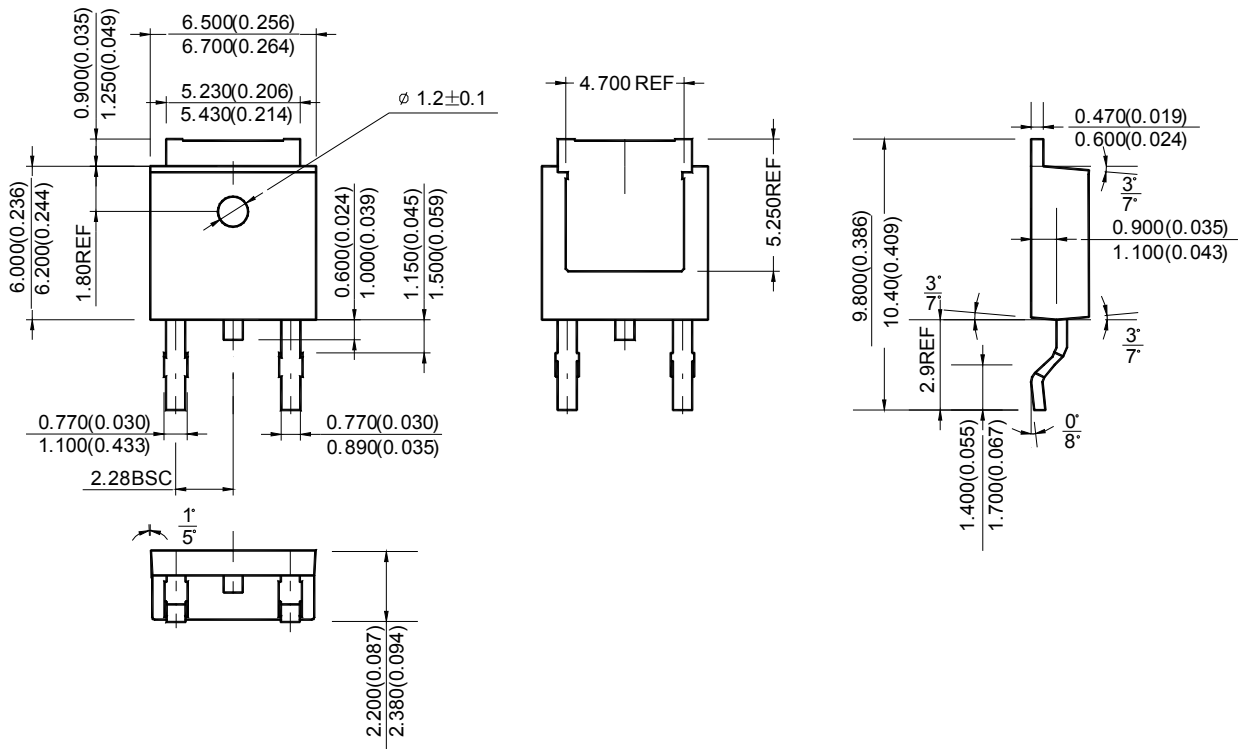



**3A LOW DROPOUT LINEAR REGULATOR**

**AZ1085**

**Mechanical Dimensions (Continued)**

**TO-252-2 (3)**

**Unit: mm(inch)**

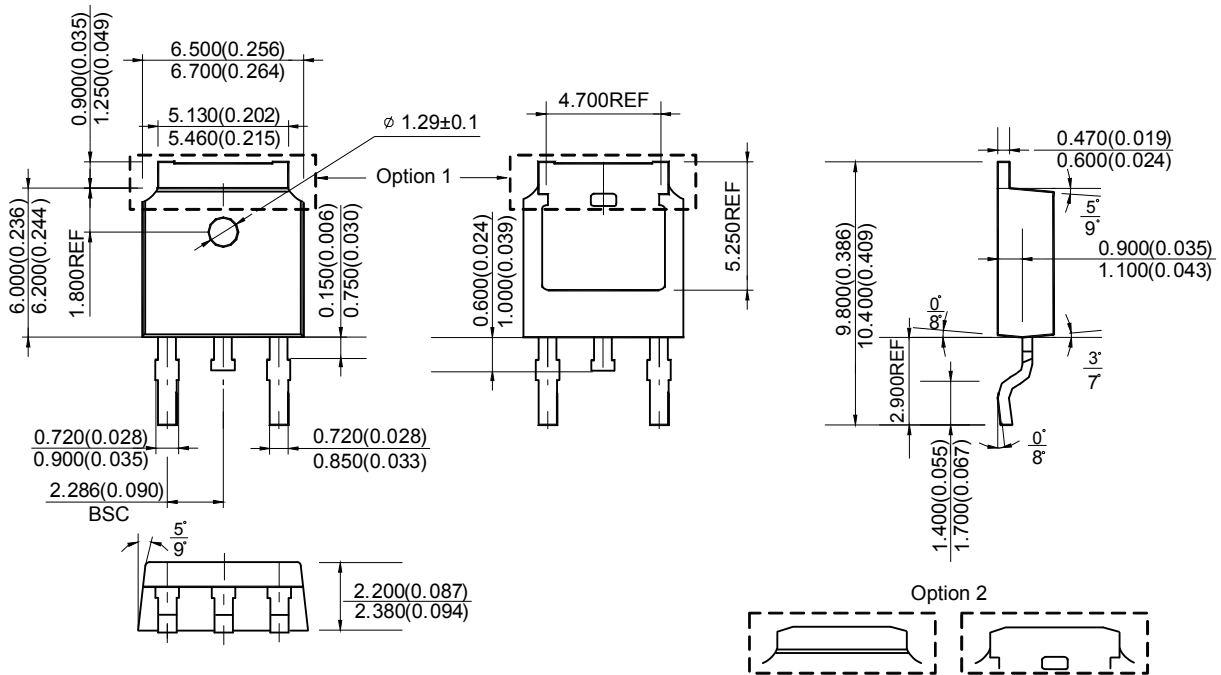



**3A LOW DROPOUT LINEAR REGULATOR**

**AZ1085**

**Mechanical Dimensions (Continued)**

**TO-252-2 (4)**

**Unit: mm(inch)**

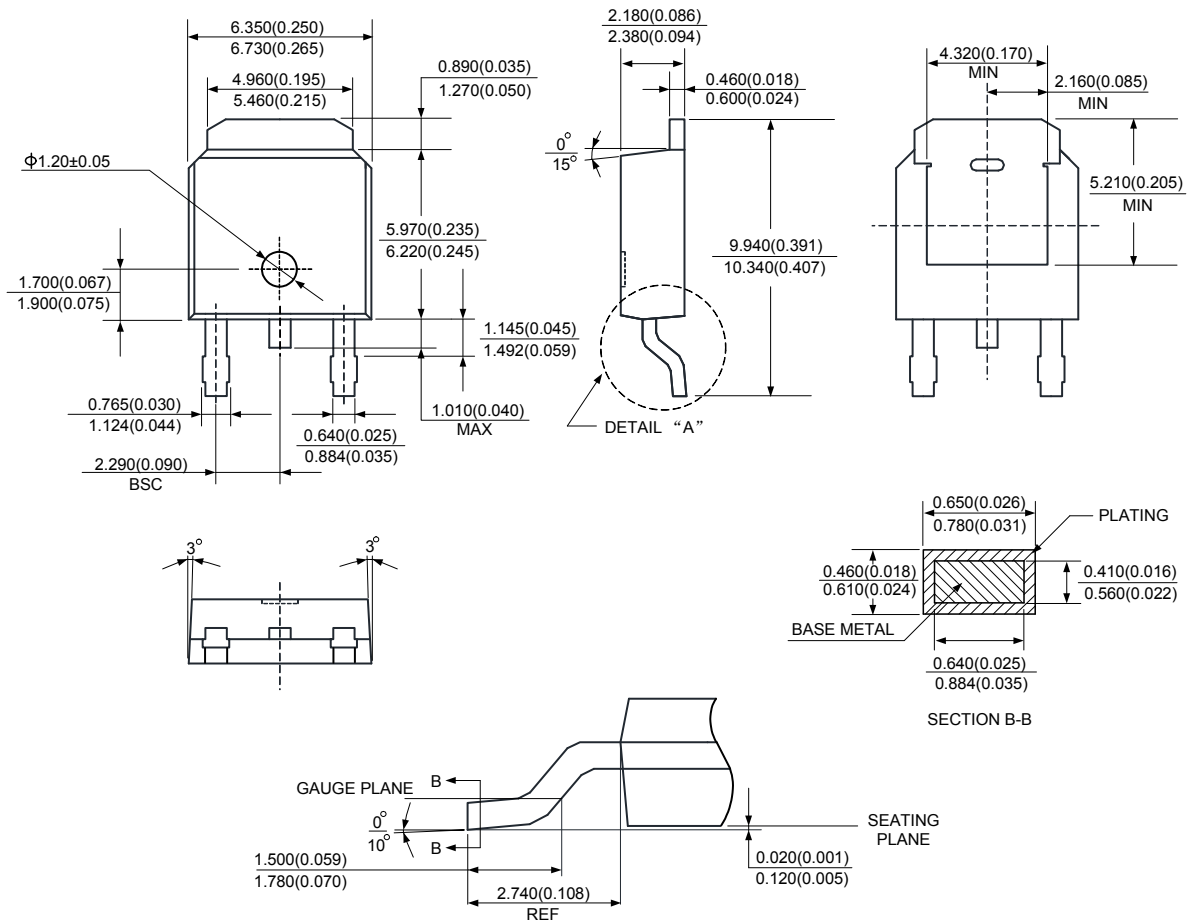



## **BCD Semiconductor Manufacturing Limited**

<http://www.bcdsemi.com>

### **IMPORTANT NOTICE**

BCD Semiconductor Manufacturing Limited reserves the right to make changes without further notice to any products or specifications herein. BCD Semiconductor Manufacturing Limited does not assume any responsibility for use of any its products for any particular purpose, nor does BCD Semiconductor Manufacturing Limited assume any liability arising out of the application or use of any its products or circuits. BCD Semiconductor Manufacturing Limited does not convey any license under its patent rights or other rights nor the rights of others.

---

#### **MAIN SITE**

##### **- Headquarters**

##### **BCD Semiconductor Manufacturing Limited**

No. 1600, Zi Xing Road, Shanghai Zizhu Science-based Industrial Park, 200241, China  
Tel: +86-21-24162266, Fax: +86-21-24162277

##### **- Wafer Fab**

##### **Shanghai SIM-BCD Semiconductor Manufacturing Co., Ltd.**

800 Yi Shan Road, Shanghai 200233, China  
Tel: +86-21-6485 1491, Fax: +86-21-5450 0008

#### **REGIONAL SALES OFFICE**

##### **Shenzhen Office**

##### **Shanghai SIM-BCD Semiconductor Manufacturing Co., Ltd., Shenzhen Office**

Unit A Room 1203, Skyworth Bldg., Gaoxin Ave. 1.S., Nanshan District, Shenzhen, China  
Tel: +86-755-8826 7951  
Fax: +86-755-8826 7865

##### **Taiwan Office**

##### **BCD Semiconductor (Taiwan) Company Limited**

4F, 298-1, Rui Guang Road, Nei-Hu District, Taipei, Taiwan  
Tel: +886-2-2656 2808  
Fax: +886-2-2656 2806

##### **USA Office**

##### **BCD Semiconductor Corp.**

30920 Huntwood Ave. Hayward, CA 94544, USA  
Tel : +1-510-324-2988  
Fax: +1-510-324-2788

## X-ON Electronics

Largest Supplier of Electrical and Electronic Components

*Click to view similar products for [LDO Voltage Regulators](#) category:*

*Click to view products by [Diodes Incorporated](#) manufacturer:*

Other Similar products are found below :

[M38D29FFHP#U1](#) [702103A](#) [717726C](#) [742457H](#) [MP20051DN-LF-Z](#) [R5F111PGGFB#30](#) [AP7363-SP-13](#) [NCP103AMX285TCG](#)  
[NCV8664CST33T3G](#) [NCV8752AMX28TCG](#) [L9454](#) [AP7362-HA-7](#) [LX13043CLD](#) [TCR3DF185,LM\(CT](#) [TCR3DF24,LM\(CT](#)  
[TCR3DF285,LM\(CT](#) [TCR3DF31,LM\(CT](#) [TCR3DF45,LM\(CT](#) [TLF4949EJ](#) [L9708](#) [L970813TR](#) [030014BB](#) [059985X](#) [EAN61387601](#)  
[EAN61573601](#) [NCP121AMX173TCG](#) [NCP4687DH15T1G](#) [NCV8703MX30TCG](#) [701326R](#) [702087BB](#) [755078E](#) [TCR2EN28,LF\(S](#)  
[LM1117DT-1.8/NO](#) [LT1086CM#TRPBF](#) [AZ1085S2-1.5TRE1](#) [MAX15101EWL+T](#) [NCV8170AXV250T2G](#) [SCD337BTG](#)  
[TCR3DF27,LM\(CT](#) [TCR3DF19,LM\(CT](#) [TCR3DF125,LM\(CT](#) [TCR2EN18,LF\(S](#) [MAX15103EWL+T](#) [TS2937CZ-5.0 C0](#) [MAX8878EUK30-](#)  
[T](#) [MAX663CPA](#) [NCV4269CPD50R2G](#) [NCV8716MT30TBG](#) [AZ1117IH-1.2TRG1](#) [MP2013GQ-P](#)