

DUAL BIPOLAR OPERATIONAL AMPLIFIERS**AZ4558C****General Description**

The AZ4558C consists of two high performance operational amplifiers. The IC features high gain, low equivalent input noise voltage, high input resistance, excellent channel separation, wide range of operating voltage and internal frequency compensation.

It can work with $\pm 18V$ maximum power supply voltage or single power supply up to 36V.

The AZ4558C is available in DIP-8 and SOIC-8 packages.

Features

- Internally Frequency Compensated
- Large Signal Voltage Gain: 100dB Typical
- Gain and Phase Match between Amplifiers
- Gain Bandwidth Product (at 10kHz): 5.5MHz
- Pin to Pin Compatible with MC1458

Applications

- Audio AC-3 Decoder System
- Audio Amplifier

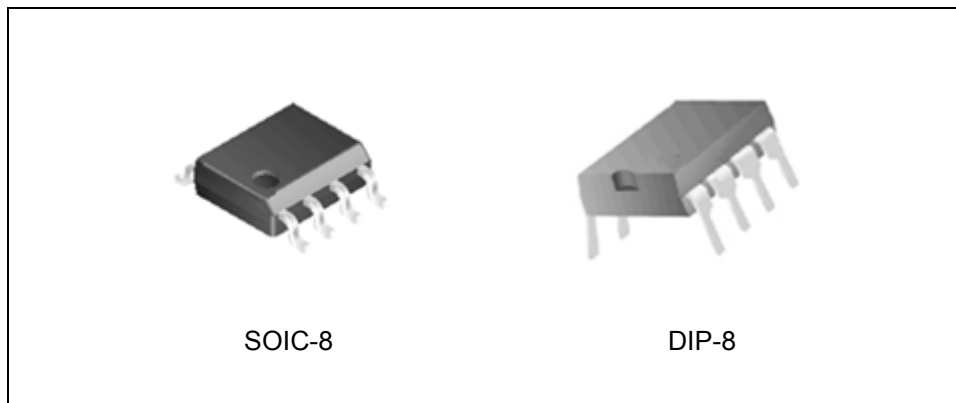

Figure 1. Package Types of AZ4558C

DUAL BIPOLAR OPERATIONAL AMPLIFIERS

AZ4558C

Pin Configuration

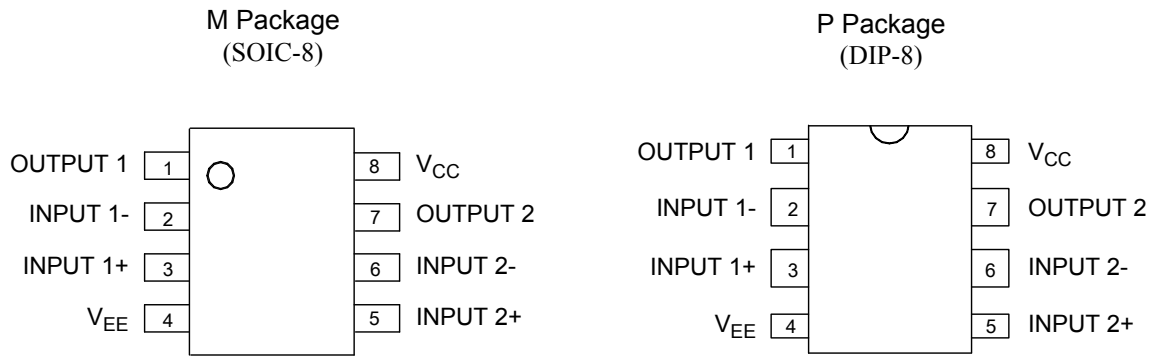

Figure 2. Pin Configuration of AZ4558C (Top View)

Functional Block Diagram

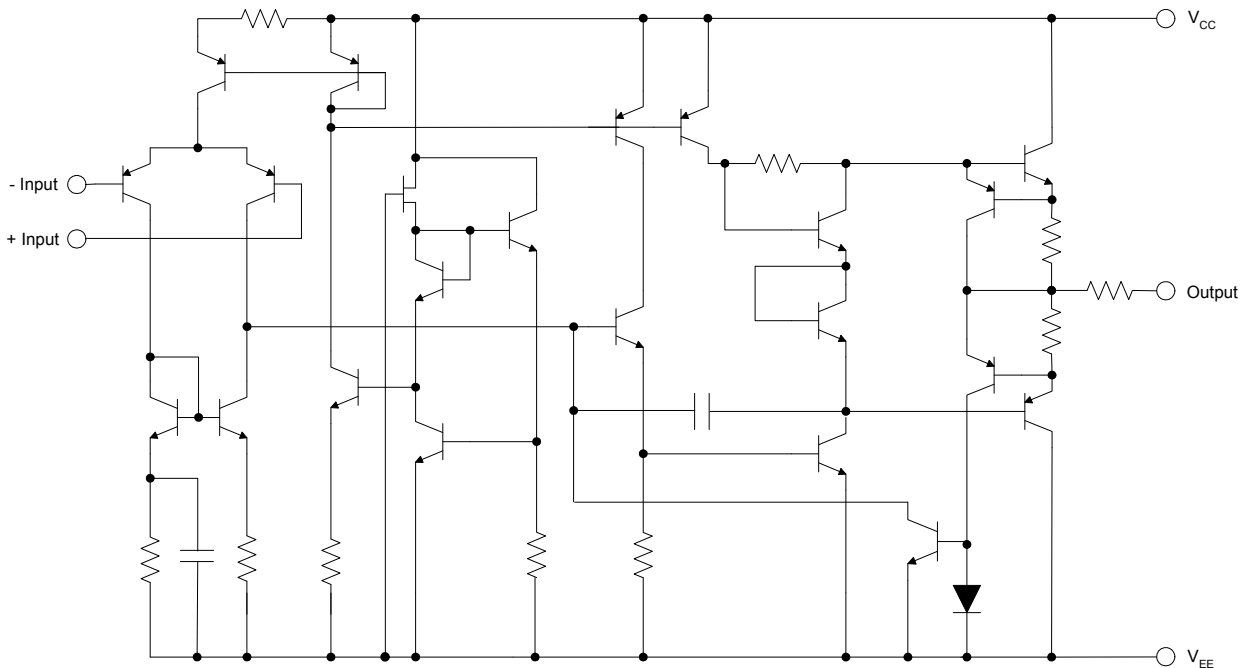

Figure 3. Functional Block Diagram of AZ4558C (Each Amplifier)



DUAL BIPOLAR OPERATIONAL AMPLIFIERS

AZ4558C

Ordering Information

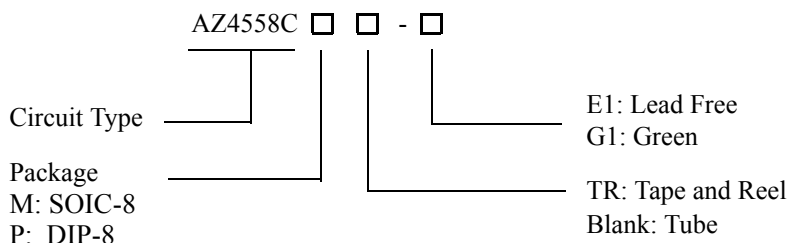

Package	Temperature Range	Part Number		Marking ID		Packing Type
		Lead Free	Green	Lead Free	Green	
SOIC-8	-40 to 85°C	AZ4558CM-E1	AZ4558CM-G1	4558CM-E1	4558CM-G1	Tube
		AZ4558CMTR-E1	AZ4558CMTR-G1	4558CM-E1	4558CM-G1	Tape & Reel
DIP-8	-40 to 85°C	AZ4558CP-E1	AZ4558CP-G1	AZ4558CP-E1	AZ4558CP-G1	Tube

BCD Semiconductor's Pb-free products, as designated with "E1" suffix in the part number, are RoHS compliant. Products with "G1" suffix are available in green packages.

Absolute Maximum Ratings (Note 1)

Parameter	Symbol	Value	Unit
Supply Voltage	V_{CC}	+20	V
	V_{EE}	-20	
Input Voltage	V_I	±15	V
Differential Input Voltage	V_{ID}	±30	V
Operating Junction Temperature	T_J	150	°C
Storage Temperature Range	T_{STG}	-65 to 150	°C
Lead Temperature (Soldering 10s)	T_L	260	°C
Power Dissipation	P_D	DIP	800 mW
		SOIC	500 mW

Note 1: Stresses greater than those listed under "Absolute Maximum Ratings" may cause permanent damage to the device. These are stress ratings only, and functional operation of the device at these or any other conditions beyond those indicated under "Recommended Operating Conditions" is not implied. Exposure to "Absolute Maximum Ratings" for extended periods may affect device reliability.

Recommended Operating Conditions

Parameter	Min	Max	Unit
Supply Voltage	±2	±18	V
Operating Temperature Range	-40	85	°C



DUAL BIPOLAR OPERATIONAL AMPLIFIERS

AZ4558C

Electrical Characteristics

Operating Conditions: $V_{CC}=+15V$, $V_{EE}=-15V$, $T_A=25^{\circ}C$, unless otherwise specified.

Parameter	Symbol	Conditions	Min	Typ	Max	Unit
Input Offset Voltage	V_{IO}			1	5	mV
Input Offset Current	I_{IO}	$V_{CM}=0V$		10	100	nA
Input Bias Current	I_{IB}	$V_{CM}=0V$		70	400	nA
Large Signal Voltage Gain	A_{VD}	$R_L=2K\Omega$, $V_O=\pm 10V$	85	100		dB
Supply Voltage Rejection Ratio	SVR	$R_S \leq 10K\Omega$	80	100		dB
Supply Current	I_{CC}	All Amplifiers, No Load		2.5	4.5	mA
Input Common Mode Voltage Range	V_{ICM}		± 12			V
Common Mode Rejection Ratio	CMRR	$R_S \leq 10K\Omega$	70	95		dB
Output Voltage Swing	V_O	$R_L \geq 10K\Omega$	± 12	± 14		V
		$R_L \geq 2K\Omega$	± 10	± 13		
Slew Rate	SR	$V_I = \pm 10V$, $R_L = 2K\Omega$, $C_L = 100pF$, unity gain		1.8		V/ μs
Rise Time	T_R	$V_I = \pm 20mV$, $R_L = 2K\Omega$, $C_L = 100pF$, unity gain		0.3		μs
Overshoot	K_{OV}	$V_I = \pm 20mV$, $R_L = 2K\Omega$, $C_L = 100pF$, unity gain		15		%
Input Resistance	R_I			0.5		M Ω
Output Resistance	R_O			45		Ω
Unity Gain Bandwidth	B	Gain=0dB		2.8		MHz
Gain Bandwidth Product	GBWP	$V_I = \pm 10mV$, $R_L = 2K\Omega$, $C_L = 100pF$, $f = 10KHz$		5.5		MHz
Total Harmonic Distortion Plus Noise	THD+N	$f = 1KHz$, $A_V = 6dB$, $R_L = 10K\Omega$, $V_O = 1V_{RMS}$		0.002		%
Equivalent Input Noise Voltage Density	e_N	$R_S = 100\Omega$, $f = 1KHz$		10		$\frac{nV}{\sqrt{Hz}}$
Output Current	I_{SINK}	$V_- = 1V$, $V_+ = 0V$, $V_O = 2V$		60		mA
	I_{SOURCE}	$V_+ = 1V$, $V_- = 0V$, $V_O = 2V$		35		
Thermal Resistance (Junction to Case)	θ_{JC}	DIP-8		55		$^{\circ}C/W$
		SOIC-8		81		



Typical Performance Characteristics

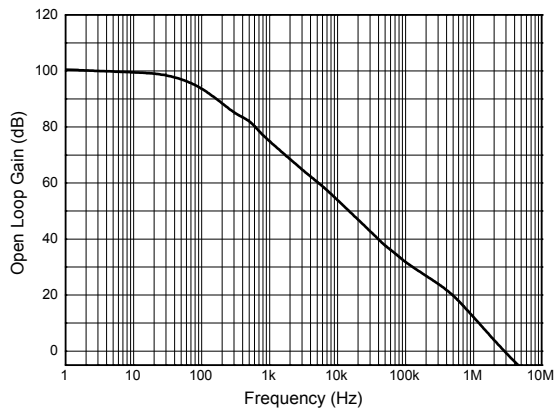

Figure 4. Open Loop Voltage Gain vs. Frequency

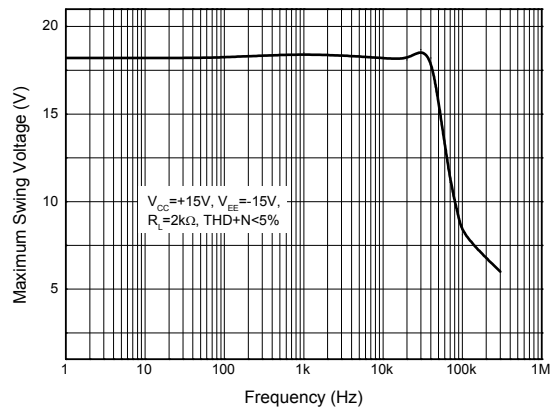

Figure 5. Maximum Output Voltage Swing vs. Frequency

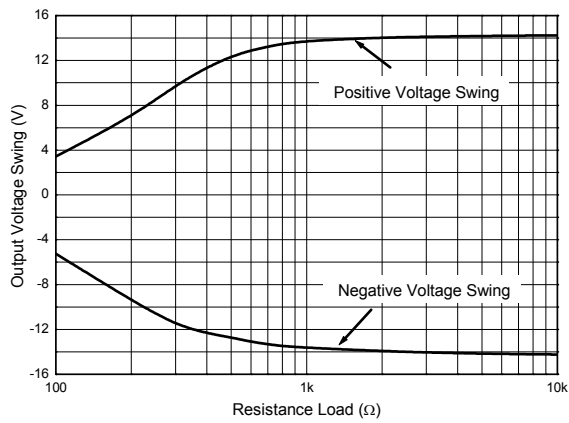

Figure 6. Maximum Output Voltage Swing vs. Load Resistance

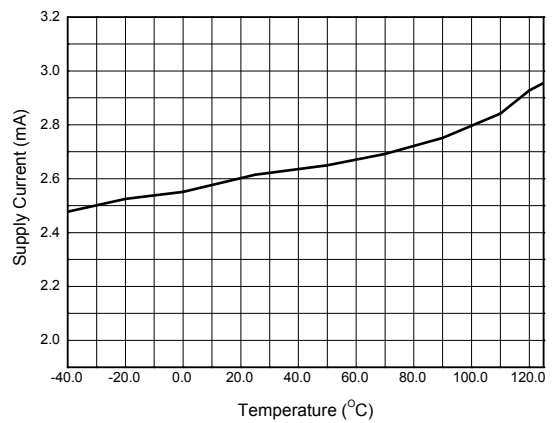

Figure 7. Supply Current vs. Temperature



Typical Performance Characteristics (Continued)

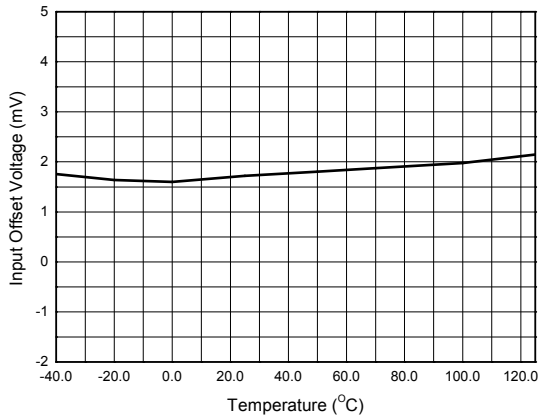

Figure 8. Input Offset Voltage vs. Temperature

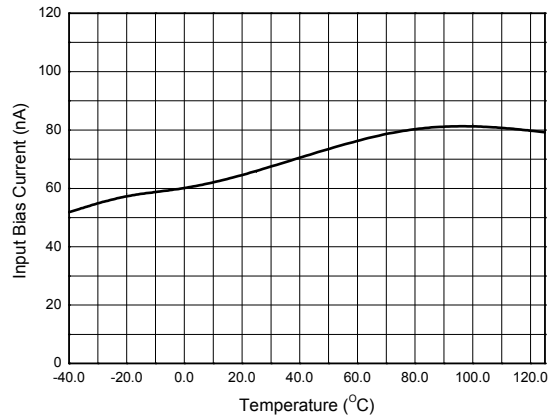

Figure 9. Input Bias Current vs. Temperature

Typical Application

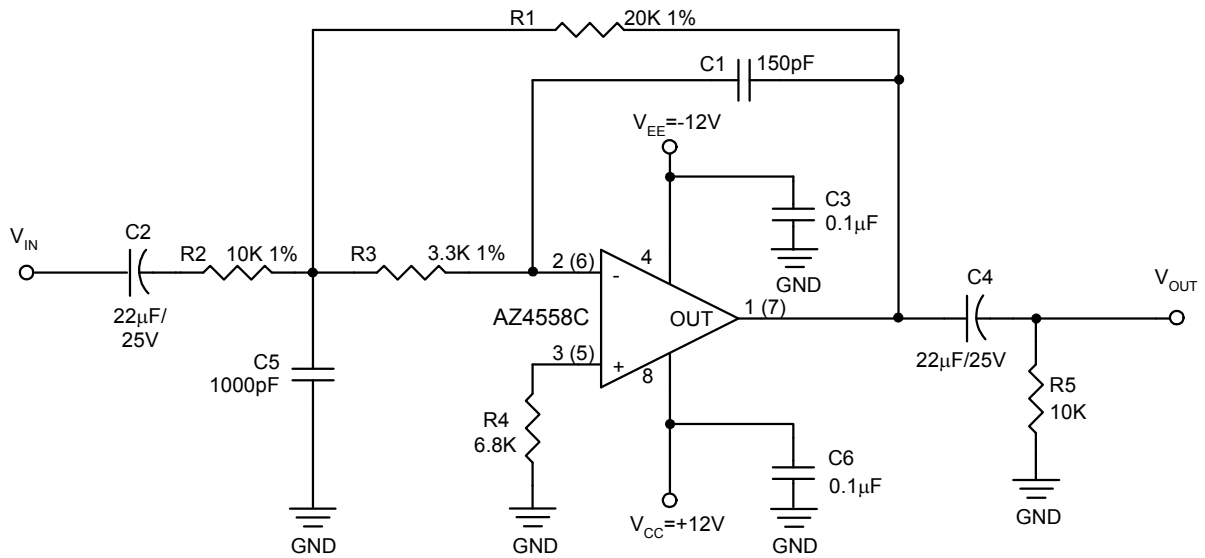

Figure 10. Typical Application of AZ4558C in Audio 2nd Order Low Pass Filter
 ($f_O=50.6\text{kHz}$, $Q=0.7015$, Input impedance=10K, Gain=6dB, Group delay=4.48µs)



DUAL BIPOLAR OPERATIONAL AMPLIFIERS

AZ4558C

Mechanical Dimensions

DIP-8

Unit: mm(inch)

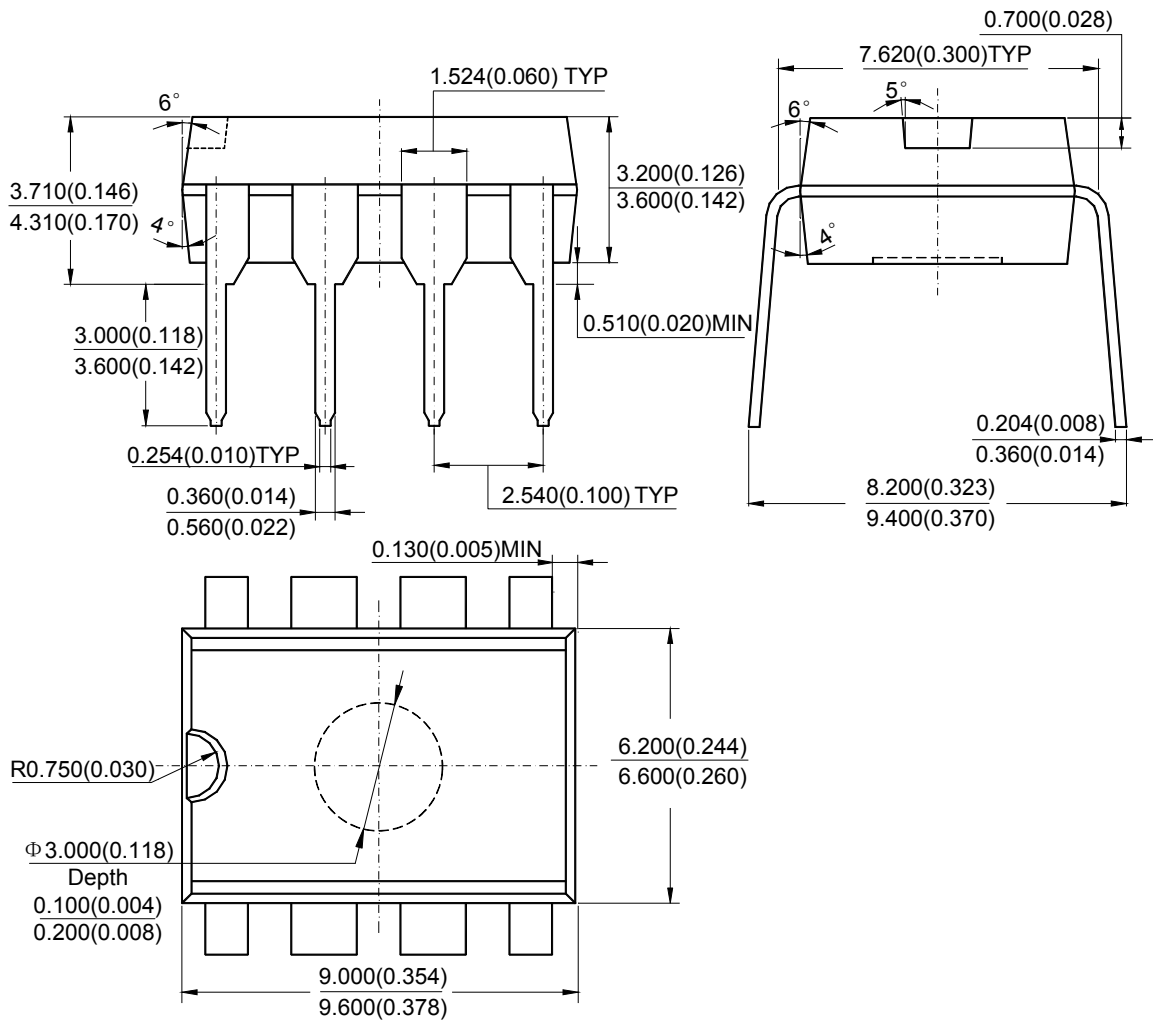

Note: Eject hole, oriented hole and mold mark is optional.



DUAL BIPOLAR OPERATIONAL AMPLIFIERS

AZ4558C

Mechanical Dimensions (Continued)

SOIC-8

Unit: mm(inch)

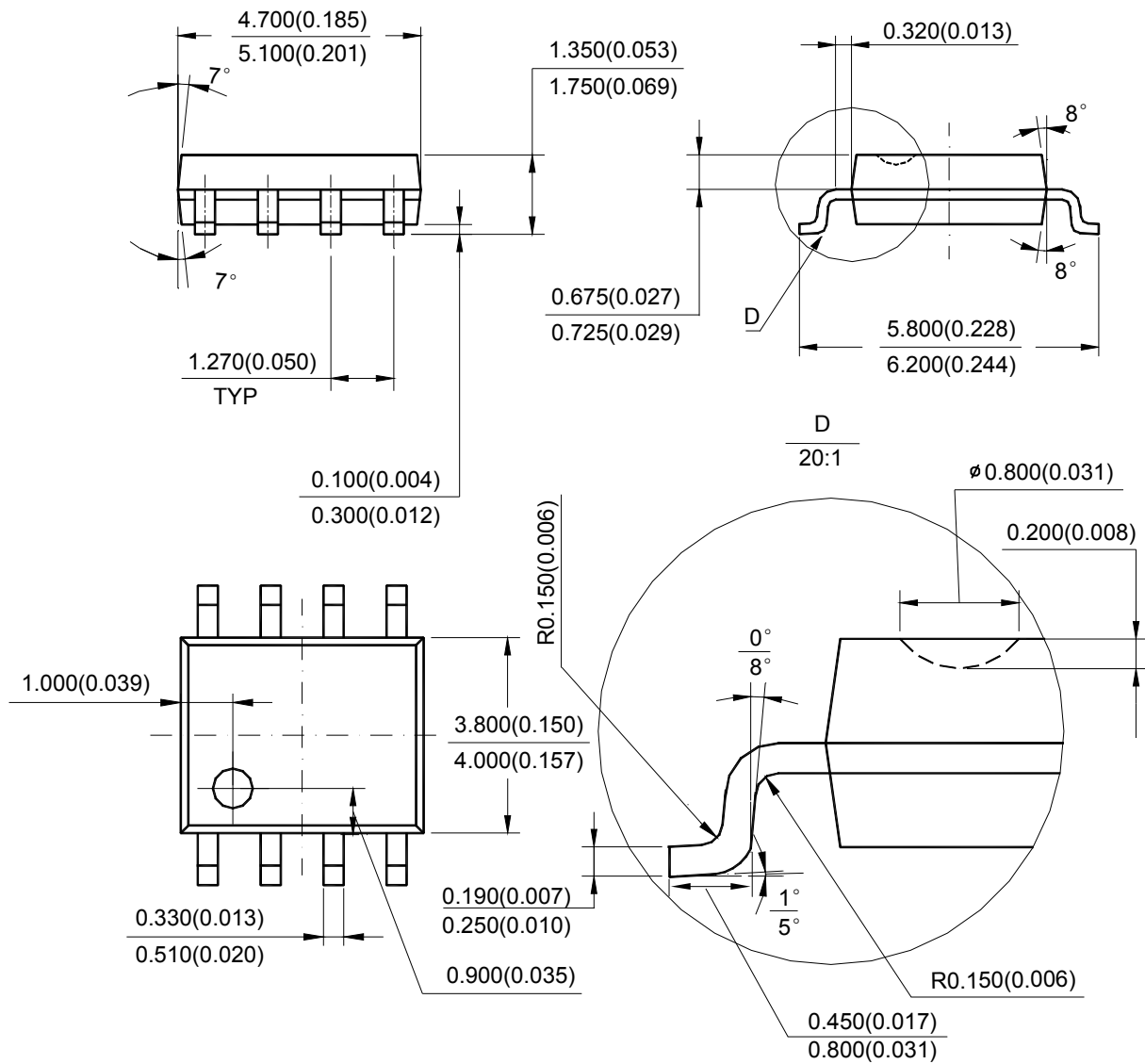

Note: Eject hole, oriented hole and mold mark is optional.



BCD Semiconductor Manufacturing Limited

<http://www.bcdsemi.com>

IMPORTANT NOTICE

BCD Semiconductor Manufacturing Limited reserves the right to make changes without further notice to any products or specifications herein. BCD Semiconductor Manufacturing Limited does not assume any responsibility for use of any its products for any particular purpose, nor does BCD Semiconductor Manufacturing Limited assume any liability arising out of the application or use of any its products or circuits. BCD Semiconductor Manufacturing Limited does not convey any license under its patent rights or other rights nor the rights of others.

MAIN SITE

- Headquarters

BCD Semiconductor Manufacturing Limited

No. 1600, Zi Xing Road, Shanghai Zizhu Science-based Industrial Park, 200241, China
Tel: +86-21-24162266, Fax: +86-21-24162277

- Wafer Fab

Shanghai SIM-BCD Semiconductor Manufacturing Co., Ltd.

800 Yi Shan Road, Shanghai 200233, China
Tel: +86-21-6485 1491, Fax: +86-21-5450 0008

REGIONAL SALES OFFICE

Shenzhen Office

Shanghai SIM-BCD Semiconductor Manufacturing Co., Ltd., Shenzhen Office

Unit A Room 1203, Skyworth Bldg., Gaoxin Ave. 1.S., Nanshan District, Shenzhen, China
Tel: +86-755-8826 7951
Fax: +86-755-8826 7865

Taiwan Office

BCD Semiconductor (Taiwan) Company Limited

4F, 298-1, Rui Guang Road, Nei-Hu District, Taipei, Taiwan
Tel: +886-2-2656 2808
Fax: +886-2-2656 2806

USA Office

BCD Semiconductor Corp.

30920 Huntwood Ave. Hayward, CA 94544, USA
Tel : +1-510-324-2988
Fax: +1-510-324-2788

X-ON Electronics

Largest Supplier of Electrical and Electronic Components

Click to view similar products for [Operational Amplifiers - Op Amps](#) category:

Click to view products by [Diodes Incorporated](#) manufacturer:

Other Similar products are found below :

[LM358SNG](#) [430227FB](#) [UPC824G2-A](#) [LT1678IS8](#) [042225DB](#) [058184EB](#) [UPC259G2-A](#) [NTE925](#) [AZV358MTR-G1](#) [AP4310AUMTR-AG1](#)
[HA1630D02MMEL-E](#) [HA1630S01LPEL-E](#) [NJU77806F3-TE1](#) [NCV20034DR2G](#) [LM324EDR2G](#) [LM2902EDR2G](#) [NTE778S](#) [NTE871](#)
[NTE924](#) [NTE937](#) [MCP6V17T-E/MNY](#) [MCP6V19-E/ST](#) [MCP6V36UT-E/LTY](#) [MXD8011HF](#) [SCY6358ADR2G](#) [LTC2065HUD#PBF](#)
[NJM2904CRB1-TE1](#) [2SD965T-R](#) [RS6332PXK](#) [BDM8551](#) [BDM321](#) [MD1324](#) [COS8052SR](#) [COS8552SR](#) [COS8554SR](#) [COS2177SR](#)
[COS2353SR](#) [COS724TR](#) [LM2902M/TR](#) [ASOPD4580S-R](#) [RS321BKXF](#) [ADA4097-1HUIZ-RL7](#) [NCV4333DTBR2G](#) [EL5420CRZ-T7A](#)
[AS324MTR-E1](#) [AS358MMTR-G1](#) [MCP6472T-E/MS](#) [MCP6491T-ELTY](#) [MCP662-E/MF](#) [TLC073IDGQR](#)