

Miniature Quartz Crystal Ceramic SMD

FLQ

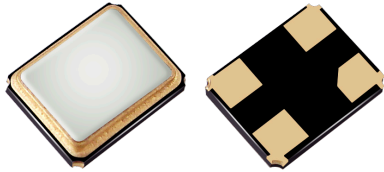

3.2 x 2.5mm Ceramic SMD

Product Features

- Rugged AT-cut crystal construction
- Miniature 3.2 x 2.5mm ceramic package
- Available on tape & reel; 8mm tape, 3000 units per reel
- Pb-free and RoHS/Green compliant
- Support high temperature up to 125°C
- Wide frequency range -8~66MHz
- AEC-Q200 compliant
-Grade 3, Grade 2, Grade 1

Product Description

The 4-pad FLQ Series seam seal devices incorporate a sub-miniature AT-cut crystal resonator housed in a standard 3.2 x 2.5mm ceramic package. These compact crystals are ideal for surface mounting in densely populated or small form-factor PCB applications. The FLQ series is designed to meet the requirements of AEC-Q200 Grade 3, Grade 2 and Grade 1 for automotive applications, and supports operating temperature range of -40 up to +125°C.

Applications

- Automotive

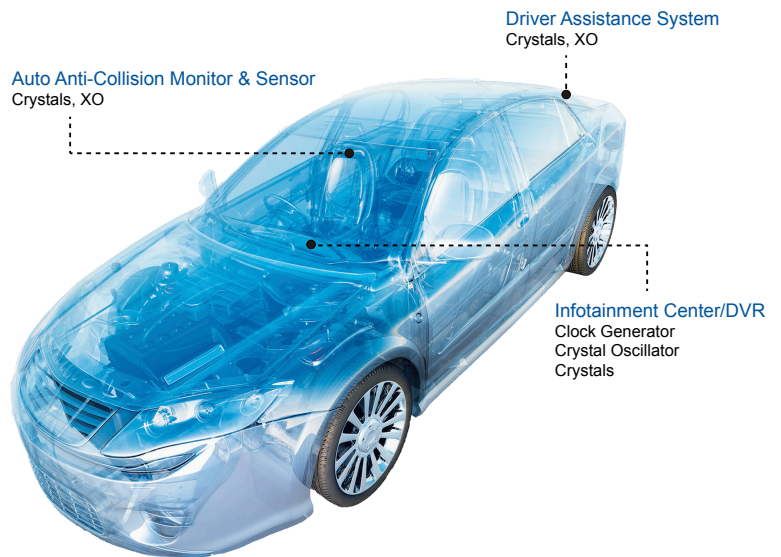

Top view pin location

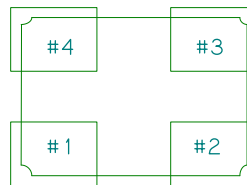

Pin Functions:

Pin	Function
1	Xtal
2	Case
3	Xtal
4	Case

Part Ordering Information:

FL XXX YYYY Q

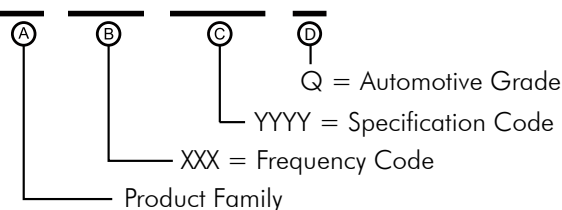

Following the above format, Saronix-eCera part numbers will be assigned upon confirmation of exact customer requirements.

Miniature Quartz Crystal Ceramic SMD FLQ



A product Line of
Diodes Incorporated



AEC-Q200 Qualified
High Temperature Crystal
3.2 x 2.5mm

Frequency Range:

- 8 MHz to 66.0000 MHz (Fundamental)

Characteristics at 25°C ±2°C:

- Frequency Calibration Tolerance: ±10ppm, ±20ppm, or ±30ppm
- Load Capacitance: 8 to 32pF or Series Resonance
- Effective Series Resistance (ESR):
 - 500Ω max (8 to 11.9 MHz)
 - 80Ω max (12 to 19.9 MHz)
 - 60Ω max (20 to 29.9 MHz)
 - 40Ω max (30 to 66 MHz)
- Drive Level: 10μW typ. (100μW max)
- Shunt Capacitance: 5pF Max

Temperature Range:

- Operating: -20 to +70°C or -40 to +85°C or -40 to +125°C
- Storage: -55 to +125°C

Temperature Stability:

- ±10ppm, ±20ppm, ±30ppm, or ±50ppm (-20 to +70°C)
- ±30ppm, or ±50ppm (-40 to +85°C)
- ±50ppm, or ±70ppm (-40 to 125°C)

Aging at 25°C, First Year:

- ±3ppm Max

Reflow Temperature:

- 260°C Max, 10 seconds Max

Mechanical

- Shock: JESD22-B104 Condition B
- Solderability: J-STD-002
- Terminal Strength: MIL-STD-883 Method 2004
- Vibration: JESD22-B103
- Solvent Resistance: JESD22-B107
- Resistance to Soldering Heat: J-STD-020C Table 5-2 Pb-free devices (3 cycles max)

Environmental

- Gross Test Leak: JESD22-A109, Condition C
- Fine Test Leak: JESD22-A109, Condition A1
- Moisture Resistance: JESD22-A113
- Insulation Resistance: 500 MΩ min (100 VDC)

Package: (Scale: none; dimensions are in mm)

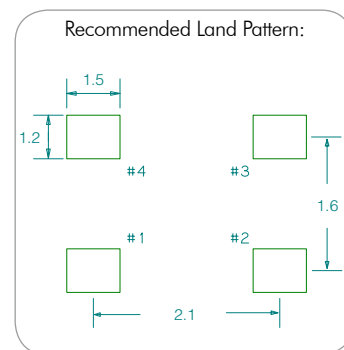
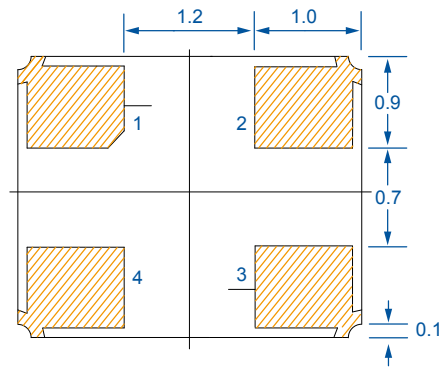
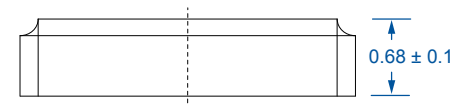
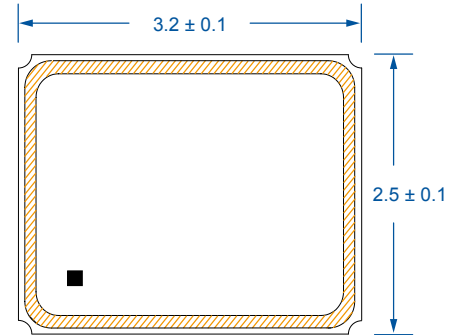

IMPORTANT NOTICE

DIODES INCORPORATED MAKES NO WARRANTY OF ANY KIND, EXPRESS OR IMPLIED, WITH REGARDS TO THIS DOCUMENT, INCLUDING, BUT NOT LIMITED TO, THE IMPLIED WARRANTIES OF MERCHANTABILITY AND FITNESS FOR A PARTICULAR PURPOSE (AND THEIR EQUIVALENTS UNDER THE LAWS OF ANY JURISDICTION).

Diodes Incorporated and its subsidiaries reserve the right to make modifications, enhancements, improvements, corrections or other changes without further notice to this document and any product described herein. Diodes Incorporated does not assume any liability arising out of the application or use of this document or any product described herein; neither does Diodes Incorporated convey any license under its patent or trademark rights, nor the rights of others. Any Customer or user of this document or products described herein in such applications shall assume all risks of such use and will agree to hold Diodes Incorporated and all the companies whose products are represented on Diodes Incorporated website, harmless against all damages.

Diodes Incorporated does not warrant or accept any liability whatsoever in respect of any products purchased through unauthorized sales channel.

Should Customers purchase or use Diodes Incorporated products for any unintended or unauthorized application, Customers shall indemnify and hold Diodes Incorporated and its representatives harmless against all claims, damages, expenses, and attorney fees arising out of, directly or indirectly, any claim of personal injury or death associated with such unintended or unauthorized application.

Products described herein may be covered by one or more United States, international or foreign patents pending. Product names and markings noted herein may also be covered by one or more United States, international or foreign trademarks.

This document is written in English but may be translated into multiple languages for reference. Only the English version of this document is the final and definitive format released by Diodes Incorporated.

LIFE SUPPORT

Diodes Incorporated products are specifically not authorized for use as critical components in life support devices or systems without the express written approval of the Chief Executive Officer of Diodes Incorporated. As used herein:

- A. Life support devices or systems are devices or systems which:
 - 1. are intended to implant into the body, or
 - 2. support or sustain life and whose failure to perform when properly used in accordance with instructions for use provided in the labeling can be reasonably expected to result in significant injury to the user.
- B. A critical component is any component in a life support device or system whose failure to perform can be reasonably expected to cause the failure of the life support device or to affect its safety or effectiveness.

Customers represent that they have all necessary expertise in the safety and regulatory ramifications of their life support devices or systems, and acknowledge and agree that they are solely responsible for all legal, regulatory and safety-related requirements concerning their products and any use of Diodes Incorporated products in such safety-critical, life support devices or systems, notwithstanding any devices- or systems-related information or support that may be provided by Diodes Incorporated. Further, Customers must fully indemnify Diodes Incorporated and its representatives against any damages arising out of the use of Diodes Incorporated products in such safety-critical, life support devices or systems.

Copyright © 2016, Diodes Incorporated
www.diodes.com

X-ON Electronics

Largest Supplier of Electrical and Electronic Components

Click to view similar products for [Crystals](#) category:

Click to view products by [Diodes Incorporated](#) manufacturer:

Other Similar products are found below :

[CX3225GB25000M0PPSZ1](#) [718-13.2-1](#) [7A-40.000MAAE-T](#) [FL2000085](#) [99-BU](#) [9B-15.360MBBK-B](#) [9C-7.680MBBK-T](#) [H10S-12.000-18-EXT-TR](#) [ABC2-6.000MHZ-D4Z-T](#) [ABLS-20.000MHZ-D2-T](#) [ABM3B-27.000MHZ-D4Y-T](#) [ABS071-32.768KHZ-6-T](#) [R38-32.768-12.5-5PPM-NPB](#) [BTD1062E05A-513](#) [C711980XFAS30XX](#) [21U15A-21.4MHZ](#) [RTX-781DF1-S-20.950](#) [LFXTAL066198Cutt](#) [9C-14.31818MBBK-T](#) [A-11.000MHZ-27](#) [ABL-27.000MHZ-B4Y-T](#) [ABM11-132-24.000MHZ-T3](#) [ABM3B1-25.000MHZ-D2Y-T](#) [SPT2A-.032768B](#) [SPT2A.032768G](#) [SSPT7F-9PF20-R](#) [LFXTAL065253Cutt](#) [LFXTAL066431Cutt](#) [XT9S20ANA14M7456](#) [XT9SNLANA16M](#) [7A-24.576MBBK-T](#) [7B-30.000MBBK-T](#) [CX2520DB16000H0HPQCC](#) [MMCC2R32.7680KHZ](#) [7A-14.31818MBBK-T](#) [6504-202-1501](#) [6526-202-1501](#) [ABLS-12.000MHZ-B2Y-T](#) [7A-10.000MBBK-T](#) [SG636PCE-20.000MC](#) [3404](#) [CM315D32768EZFT](#) [C1E-24.000-7-2020-R](#) [C1E-19.200-12-1530-X-R](#) [C1E-16.000-12-1530-X-R](#) [ABM11-16.000MHZ-9-B1U-T](#) [FL5000014](#) [EUCA18-3.1872M](#) [FX0800015](#)
[425F35E027M0000](#)