

Electrical Performance

Parameter	Min.	Typ.	Max.	Units	Notes
Output frequency	1.544		156.25	MHz	As specified
Supply voltage	+2.97	+3.3	+3.63	V	
Supply current, output enabled			15	mA	1.544 to 32 MHz
			25		>32 to 50 MHz
			40		>50 to 80 MHz
			55		>80 to 156.25 MHz
Supply current, standby mode			10	μA	Output Hi-Z
Frequency stability			±20 to ±50	ppM	See Note 1 below
Operating temperature	-40		+85	°C	As specified
Output logic 0, VOL			10% V _{DD}	V	
Output logic 1, VOH	90% V _{DD}			V	
Output load	15 pF (max) or 10 LSTTL				
Duty cycle (1.544 to 80 MHz)	45		55	%	-40 to +85°C measured 50%VDD
Duty cycle (>80 to 156.25 MHz)	45		55	%	-10 to +70°C measured 50%VDD
Duty cycle (>80 to 156.25 MHz)	40		60	%	-40 to -10°C, +70 to +85°C measured 50%VDD
Rise and fall time	up to 50 MHz		7	ns	measured 20/80% of waveform
	>50 to 80 MHz		5		
	>80 to 125 MHz		3		
	>125 to 156.25 MHz		2		
Jitter, Phase	up to 80 MHz		1.5	ps RMS (1-σ)	10kHz to 20 MHz frequency band
	>80 to 156.25 MHz		1		
Jitter, Accumulated	up to 80 MHz		5	ps RMS (1-σ)	20.000 adjacent periods
	>80 to 156.25 MHz		3		
Jitter, Total	up to 80 MHz		50	ps pk-pk	100.000 random periods
	>80 to 156.25 MHz		30		

Notes:

- As specified. Stability includes all combinations of operating temperature, load changes, rated input (supply) voltage changes, initial calibration tolerance (25°C), aging (1 year at 25°C average effective ambient temperature), shock and vibration.
- For specifications other than those listed, please contact sales.

Output Enable / Disable Function

Parameter	Min.	Typ.	Max.	Units	Notes
Input Voltage (pin 1), Output Enable	2.2			V	or open
Input voltage (pin 1), Output Disable (low power standby)			0.8	V	Output is Hi-Z
Internal pullup resistance	50			kΩ	
Output disable delay			100	ns	
Output enable delay			10	ms	

Typical Accumulated Jitter

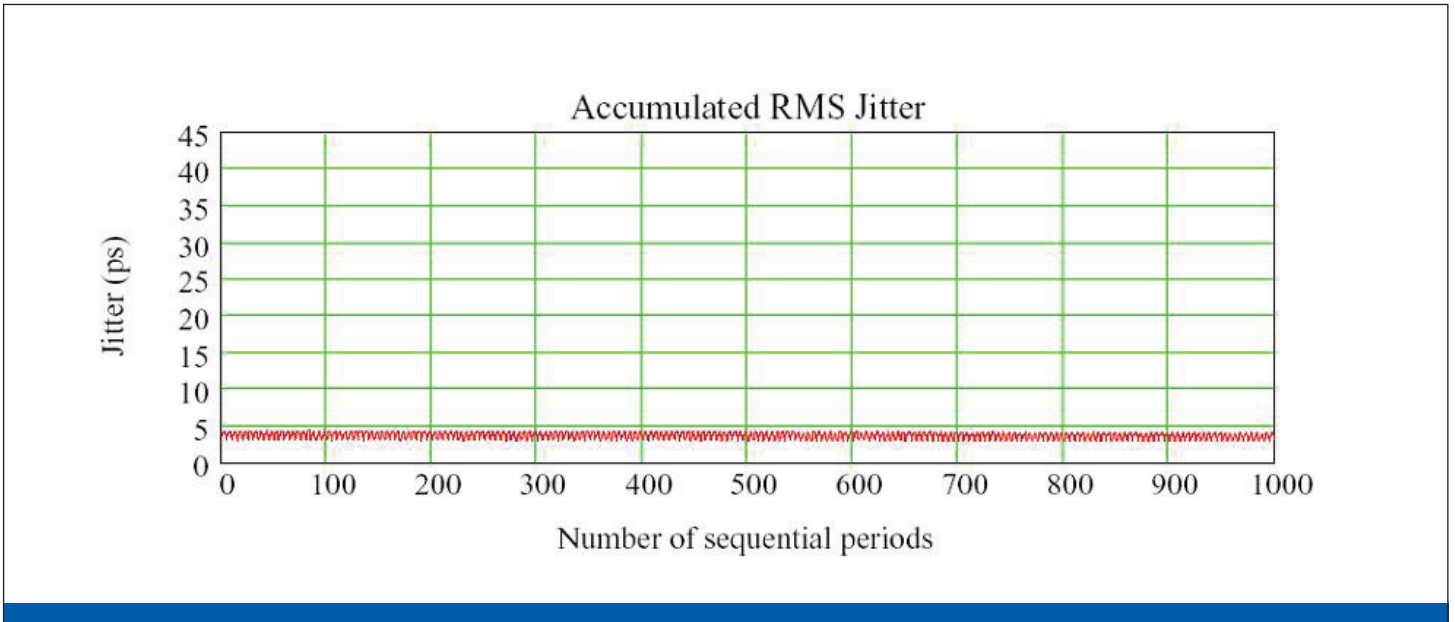

Typical Output Waveform (75 MHz output)

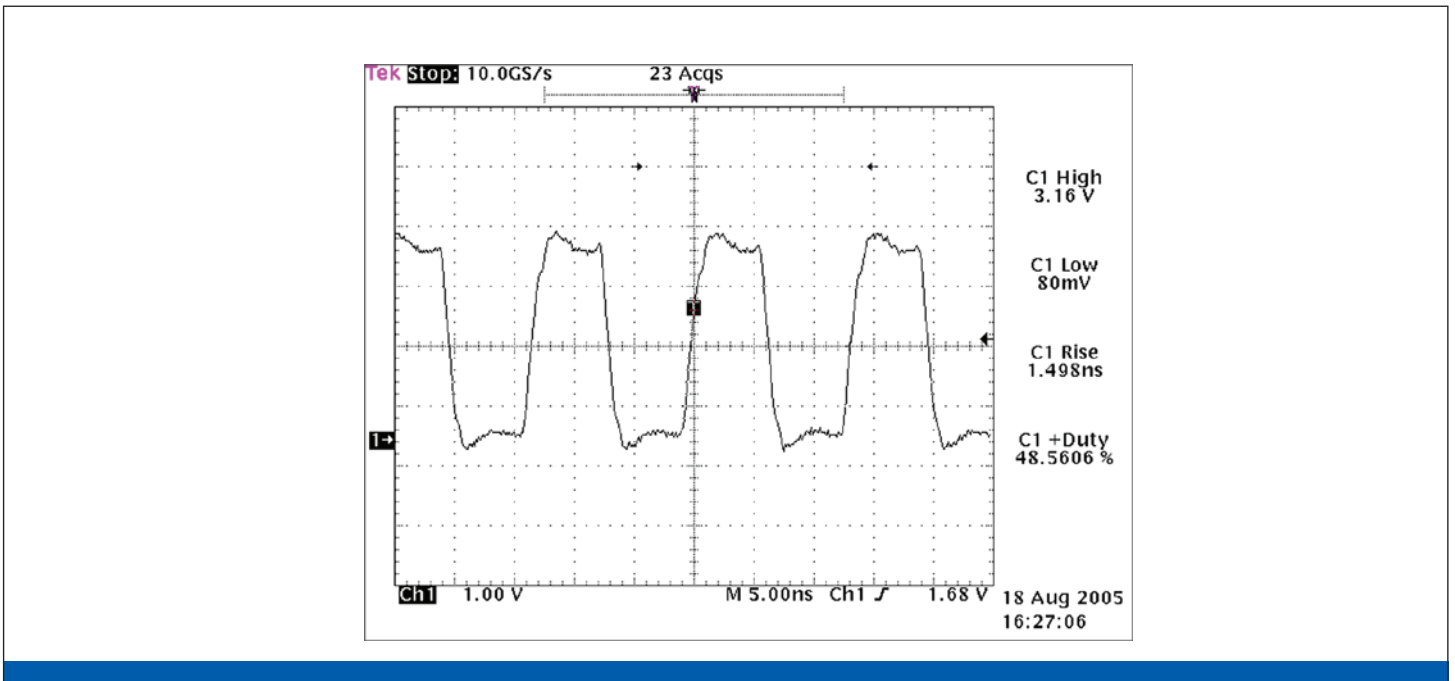

Absolute Maximum Ratings

Parameter	Min.	Typ.	Max.	Units	Notes
Storage temperature	-55		+125	°C	

Test Circuit

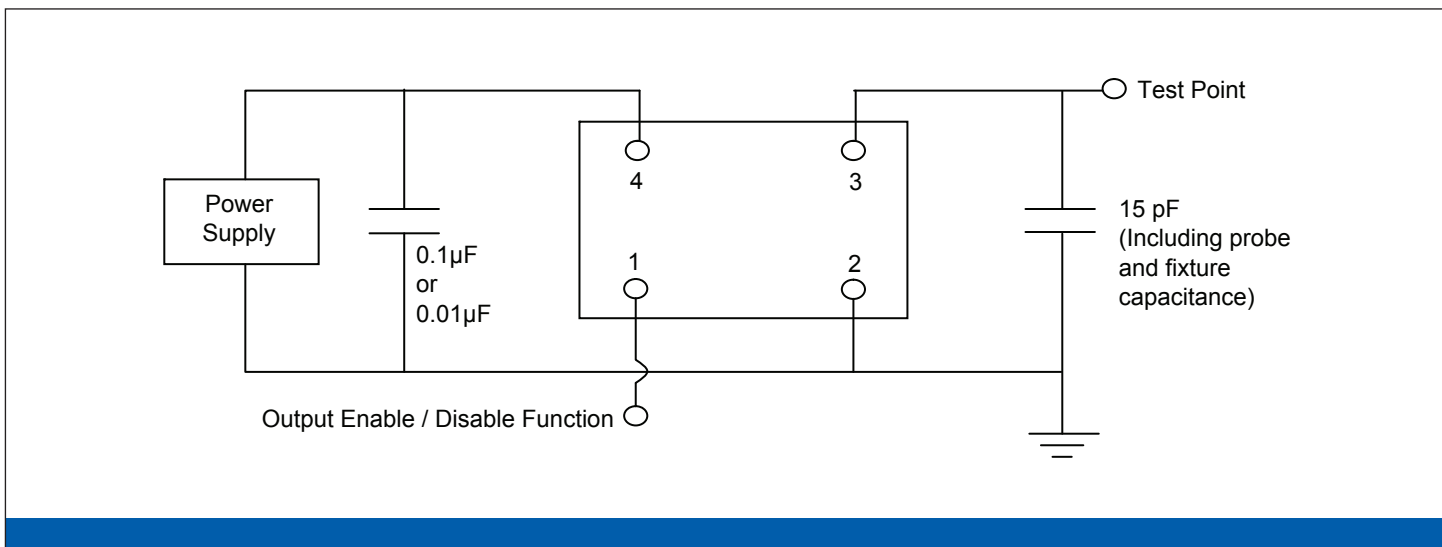

Reliability Test Ratings

This product is rated to meet the following test conditions:

Type	Parameter	Test Condition
Mechanical	Shock	MIL-STD-883, Method 2002, Condition B
Mechanical	Solderability	JESD22-B102-D Method 2 (Preconditioning E)
Mechanical	Terminal strength	MIL-STD-883, Method 2004, Condition D
Mechanical	Gross leak	MIL-STD-883, Method 1014, Condition C
Mechanical	Fine leak	MIL-STD-883, Method 1014, Condition A2 ($R_1 = 2 \times 10^{-8}$ atm cc/s)
Mechanical	Solvent resistance	MIL-STD-202, Method 215
Environmental	Thermal shock	MIL-STD-883, Method 1011, Condition A
Environmental	Moisture resistance	MIL-STD-883, Method 1004
Environmental	Vibration	MIL-STD-883, Method 2007, Condition A
Environmental	Resistance to soldering heat	J-STD-020C Table 5-2 Pb-free devices (2 cycles max)

Output Waveform

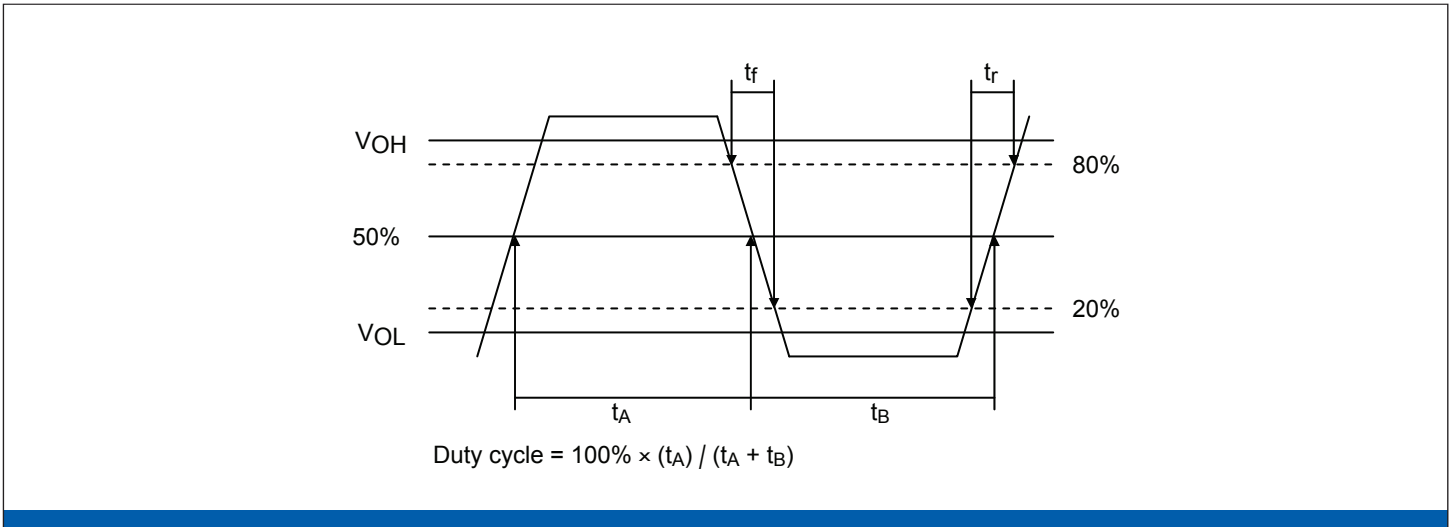

Reflow Soldering Profile

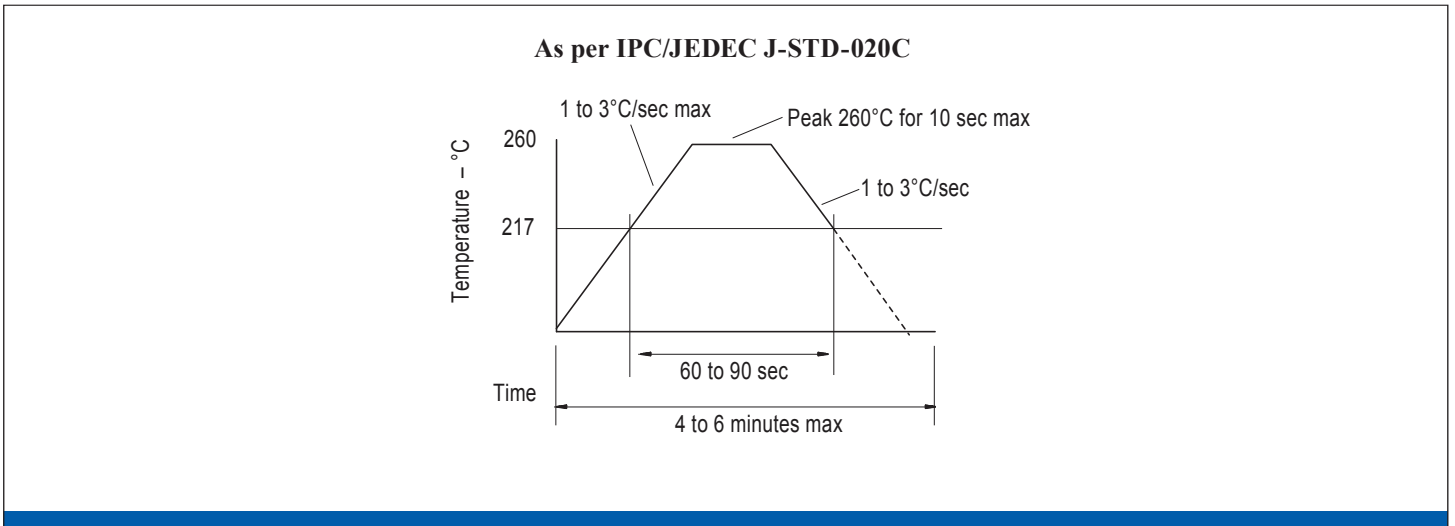

Mechanical Drawings

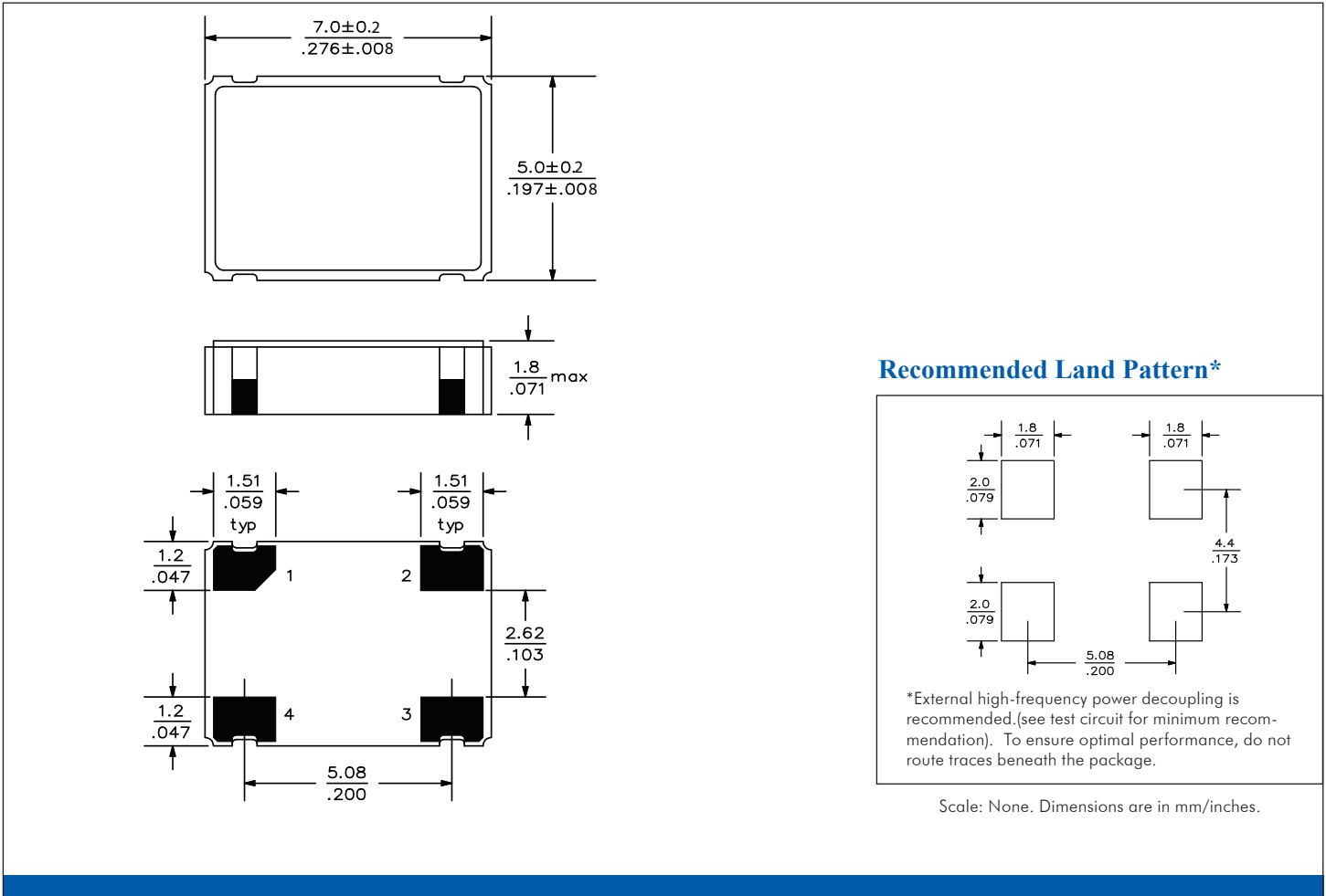

Recommended Land Pattern*

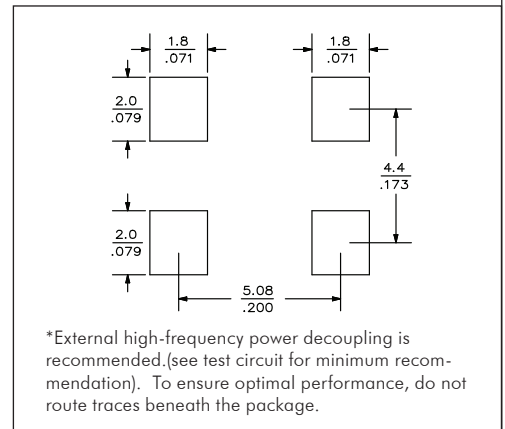

*External high-frequency power decoupling is recommended. (see test circuit for minimum recommendation). To ensure optimal performance, do not route traces beneath the package.

Scale: None. Dimensions are in mm/inches.

X-ON Electronics

Largest Supplier of Electrical and Electronic Components

Click to view similar products for [Standard Clock Oscillators](#) category:

Click to view products by [Diodes Incorporated](#) manufacturer:

Other Similar products are found below :

[601252](#) [F335-25](#) [F535L-33.333](#) [F535L-50](#) [NBXHBA019LN1TAG](#) [SiT1602BI-22-33E-50.000000E](#) [SIT8918AA-11-33S-50.000000G](#)
[SM4420TEV-40.0M-T1K](#) [F335-24](#) [F335-40](#) [F535L-10](#) [F535L-12](#) [F535L-24](#) [F535L-27](#) [PE7744DW-100.0M](#) [ASF1-3.686MHZ-N-K-S](#) [ASV-](#)
[4.000MHZ-LCS-T](#) [XLH735025.000JU4I8](#) [XLP725125.000JU6I8](#) [XO57CTECNA3M6864](#) [601251](#) [SiT8503AI-18-33E-0.200000X](#)
[SIT8918AA-11-33S-16.000000G](#) [SIT9122AI2C233E300.000000X](#) [9120AC-2D2-33E212.500000](#) [9102AI-243N25E100.00000](#) [8208AC-82-](#)
[18E-25.00000](#) [8008AI-72-XXE-24.545454E](#) [8004AC-13-33E-133.33000X](#) [AS-4.9152-16-SMD-TR](#) [ASFL1-48.000MHZ-LC-T](#)
[632L3I004M00000](#) [SIT8920AM-31-33E-25.0000](#) [DSC1028DI2-019.2000](#) [9121AC-2C3-25E100.00000](#) [9102AI-233N33E100.00000X](#)
[9102AI-233N25E200.00000](#) [9102AI-232H25S125.00000](#) [9102AI-133N25E200.00000](#) [9102AC-283N25E200.00000](#) [9001AC-33-33E1-30.000](#)
[8103AC-13-33E-12.00000X](#) [3921AI-2CF-33NZ125.000000](#) [5730-1SF](#) [XUN736000.032768I](#) [ASV-25.000MHZ-ECS-50-T](#) [EC3925ETTTS-](#)
[100.000M TR](#) [SIT1602BC-83-33E-10.000000Y](#) [8003AI-12-33S-40.00000Y](#) [1602BI-13-33S-19.200000E](#)