



PSE Technology Corporation

SPECIFICATION FOR APPROVAL

CUSTOMER	_____
NOMINAL FREQUENCY	32.768 KHz
PRODUCT TYPE	TYPE G4 SMD X'TAL
SPEC. NO. (P/N)	G43270009
CUSTOMER P/N	_____
ISSUE DATE	Mar.18,2011
VERSION	D

APPROVED	PREPARED	QA
		
APPROVED BY CUSTOMER :		AVL Status
Please return one copy with approval to PSE-TW		

PSE Technology Corporation

No.2, Tzu-Chiang 5th Rd, Chung Li Industrial Park,
 Chung Li City, Taoyuan County, Taiwan (R.O.C.)
 TEL: 886-3-451-8888
 FAX: 886-3-461-3865
<http://www.saronix-ecera.com.tw>

*RoHS Exception
 *HF-Halogen Free
 *REACH Compliant

TYPE G4 SMD X'TAL

G43270009

VER. D 18-Mar-11

VERSION HISTORY

Version No.	Version Date	Customer Receipt Date	Supplier Receipt Date	Description	Notes
A	Mar.1,2010			Initial Release	
B	Mar.2,2010			Cancel Pb-free	
C	Sep.24,2010			New Logo	
D	Mar.18,2011			Revised Format	

TYPE G4 SMD X'TAL

G43270009

VER. D 18-Mar-11

ELECTRICAL SPECIFICATIONS

SRe Part Number : G43270009

Parameters	Symbol	Specifications	Units	Notes
Nominal Frequency	Fn	32.768	KHz	
Frequency Tolerance	FT	± 20	ppm	at 25 °C ± 5 °C
Load Capacitance	CL	12.5	pF	Typ.
Drive Level	DL	1	μW	Max.
Equivalent Series Resistance	ESR	50	KΩ	Max.
Temperature Coefficient	K	-0.035	ppm/°C ²	Typ.
Shunt Capacitance	C0	1.35	pF	Typ.
Operating Temperature Range	TR	-40~85	°C	
Storage Temperature Range		-55~85	°C	
Aging		± 3	ppm	Max 1st year
Insulation Resistance		500	MΩ	Min.

Reliability (Mechanical and Environmental Endurance)

No.	Test Items	Test Method and Condition	Requirements
1	Vibration	(1) Vibration Frequency: 10 to 55Hz (2) Vibration Amplitude: 1.5mm (3) Cycle Time: 1-2min(10-55-10Hz) (4) Direction: X.Y.Z (5) Duration: 2h/each direction	Frequency Change: ±10ppm Max. Resistance Change: ±15% or 5kΩ Max.
2	Shock	3 Times free drop from 75cm height to hard wooden board of thickness more than 30mm	Frequency Change: ±10ppm Max. Resistance Change: ±15% or 5kΩ Max.
3	Leakage	Put crystal units into a hermetic container and Helium for 0.5-0.6Mpa, and keep it for 1h; Check the leakage by a Helium leak detector	Leakage: 1x10 ⁻⁸ Pa·m ³ /s Max.

TYPE G4 SMD X'TAL

G43270009

VER. D 18-Mar-11

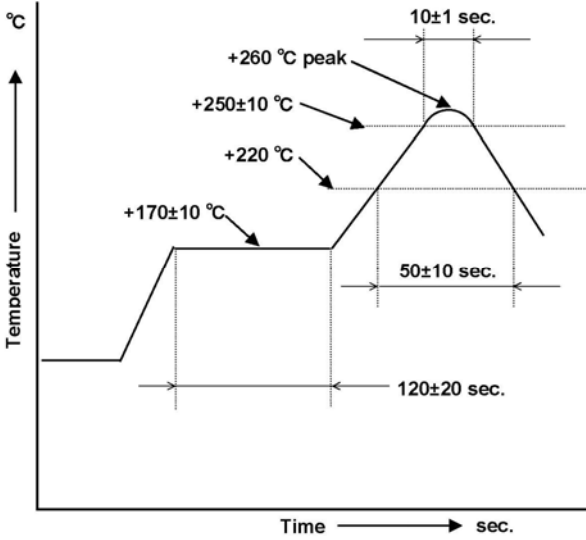
4	Reflow soldering	 <p>Note: the temperature used herein means the temperature on the circuit board. Reflow: 2 times max.</p>	<p>Frequency Change: ± 10ppm Max. Frequency Change: ± 10ppm Max. Resistance Change: $\pm 25\%$ or $10k\Omega$ Max.</p>
5	Lead Strength (DIP)	The crystal lead with the 0.9kg(9N) power (keep it for $30s \pm 5s$) and bend the crystal lead 90° with 0.45kg power and two times	The crystal lead is not abnormality
6	High Temperature Endurance	The crystal units shall be put in somewhere for 2 hrs at temperature of $-85^\circ\text{C} \pm 2^\circ\text{C}$, then keep it for 1 to 2 hrs under room temperature.	<p>Frequency Change: ± 10ppm Max. Resistance Change: $\pm 15\%$ or $5k\Omega$ Max.</p>
7	Low Temperature Endurance	The crystal units shall be put in somewhere for 2 hrs at temperature of -25°C , then keep it for 1 to 2 hrs under room temperature.	
8	Humidity Endurance	The crystal units shall be put in somewhere at 40°C in relative humidity of 90-95% for 48 hrs, then keep it for one or two hours under room temperature.	
9	Temperature Cycle	Temperature shift from low(-40°C) to high(100°C , keep 30 mins), satisfy high(100°C) to low(-40°C , keep 30 mins), then go up to room temperature for 5 cycles.	
10	Salt Spray Test	Put the crystal units in the salt spray room (salt density: 5%) at the temperature of 35°C for 96 hrs. Then clean it with water and dry its surface.	<p>The appearance shall has no abnormality and soldering is good. Frequency Change: ± 10ppm Max. Resistance Change: $\pm 15\%$ or $5k\Omega$ Max.</p>

TYPE G4 SMD X'TAL

G43270009

VER. D 18-Mar-11

Marking

32768

Dimensions (Units: mm)

● OUTLINE DRAWING

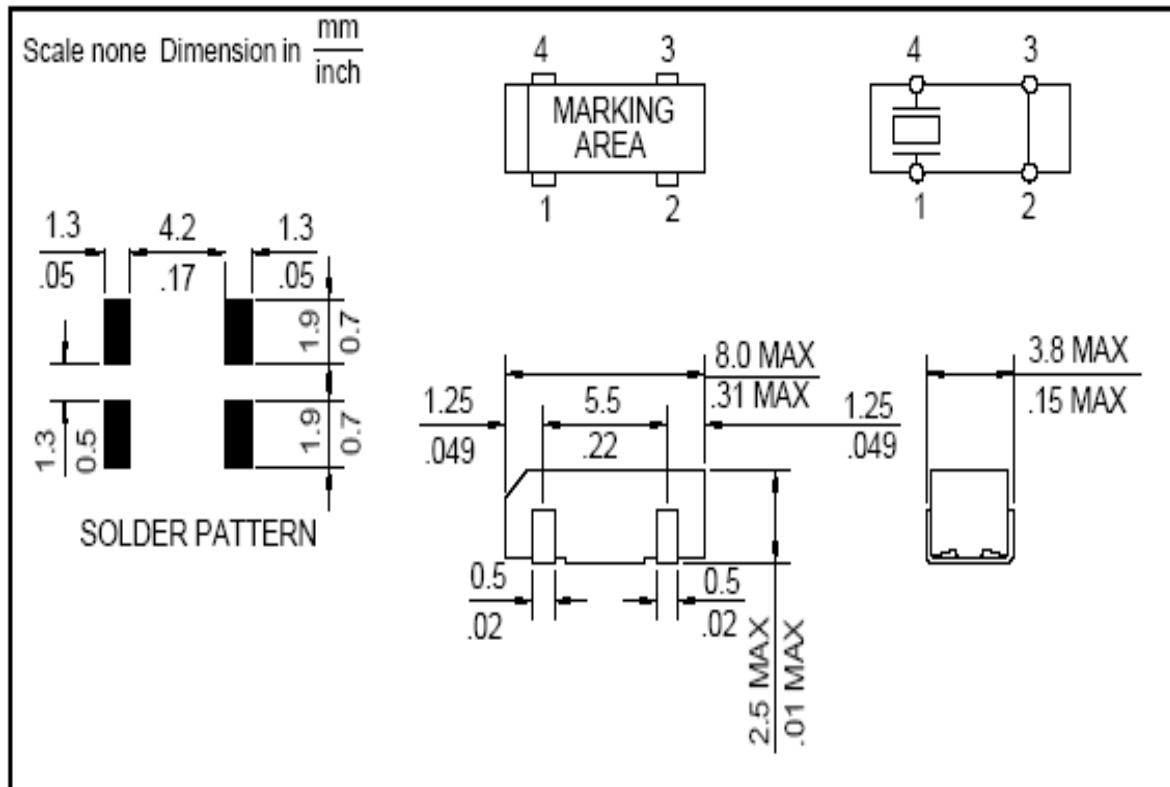

TYPE G4 SMD X'TAL

G43270009

VER. D 18-Mar-11

TAPE AND REEL SPECIFICATION

1. Tape and Reel form conform to EIA-481-B
2. The quantity of crystal units per reel shall be 3000PCS.
3. A "LABEL" on which necessary information is clearly written is on the surface of packing box and the reel.

CARRIER TAPE DIMENSIONS

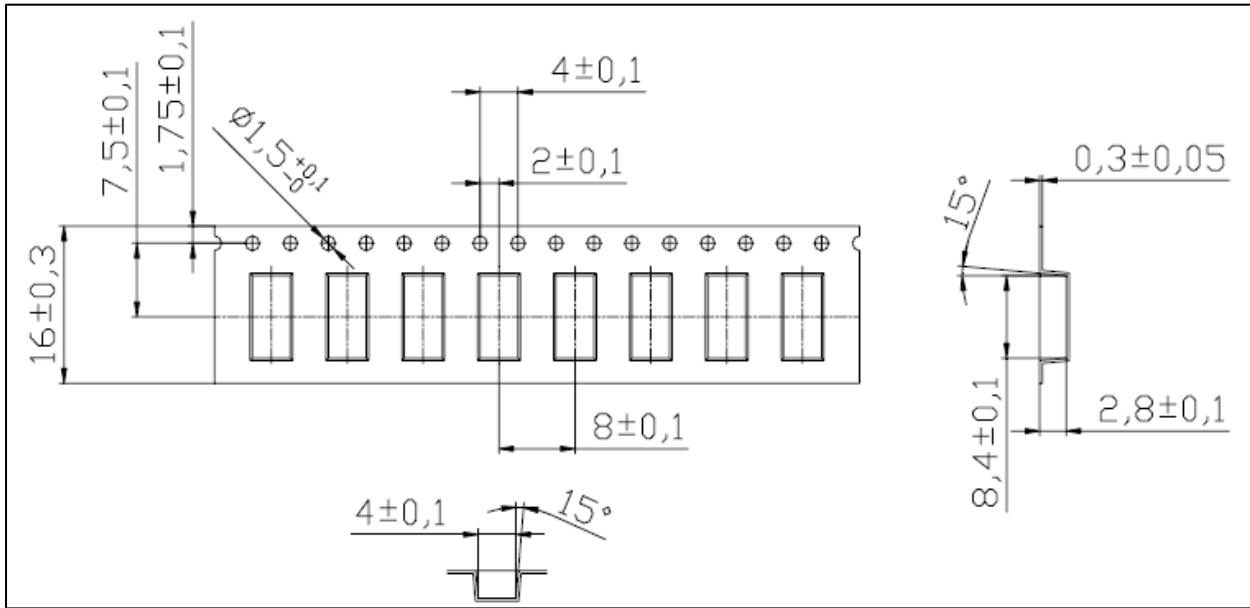

REEL DIMENSIONS

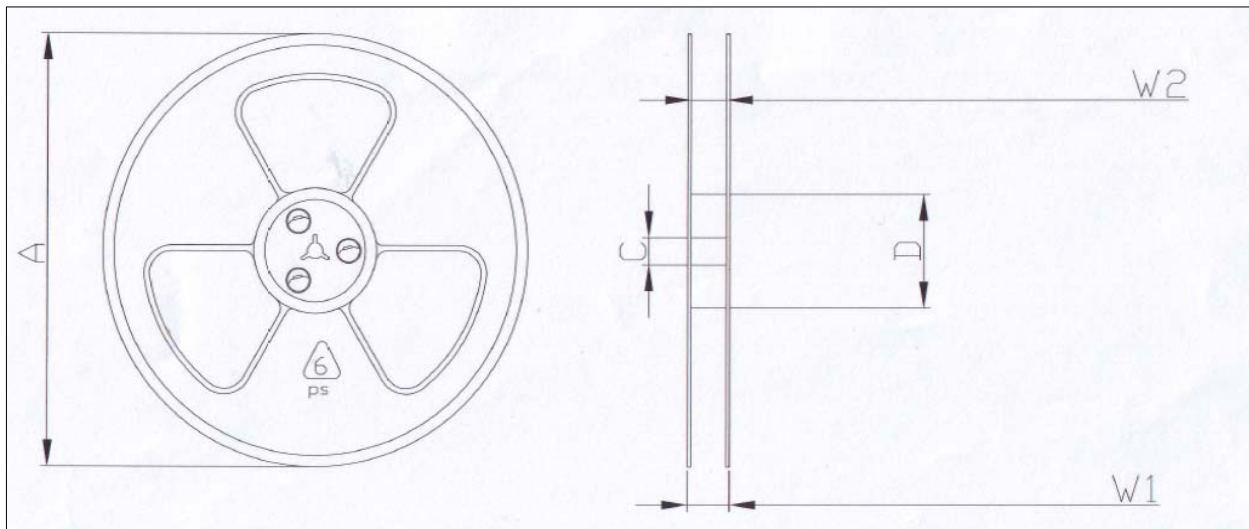

規格	A $\pm 0,5$	C $\pm 0,2$	D $\pm 0,3$	W1 $\pm 0,2$	W2 $\begin{smallmatrix} +0,4 \\ -0,2 \end{smallmatrix}$
330*100*16	330	25	100	20	16

X-ON Electronics

Largest Supplier of Electrical and Electronic Components

Click to view similar products for [Crystals](#) category:

Click to view products by [Diodes Incorporated](#) manufacturer:

Other Similar products are found below :

[CX3225GB25000M0PPSZ1](#) [718-13.2-1](#) [MC405 32.0000K-R3:PURE SN](#) [7A-40.000MAAE-T](#) [FL2000085](#) [99-BU](#) [9B-15.360MBBK-B](#) [9C-7.680MBBK-T](#) [H10S-12.000-18-EXT-TR](#) [ABC2-6.000MHZ-D4Z-T](#) [ABLS-20.000MHZ-D2-T](#) [ABS071-32.768KHZ-6-T](#) [R38-32.768-12.5-5PPM-NPB](#) [BTD1062E05A-513](#) [21U15A-21.4MHZ](#) [RTX-781DF1-S-20.950](#) [LFX TAL066198Cutt](#) [9C-14.31818MBBK-T](#) [A-11.000MHZ-27](#) [ABL-27.000MHZ-B4Y-T](#) [ABM11-132-24.000MHZ-T3](#) [ABM3B1-25.000MHZ-D2Y-T](#) [SPT2A-.032768B](#) [SPT2A.032768G](#) [SSPT7F-9PF20-R](#) [LFX TAL065253Cutt](#) [LFX TAL066431Cutt](#) [XT9S20ANA14M7456](#) [XT9SNLANA16M](#) [7A-24.576MBBK-T](#) [7B-30.000MBBK-T](#) [MMCC2R32.7680KHZ](#) [7A-14.31818MBBK-T](#) [6504-202-1501](#) [6526-202-1501](#) [ABLS-12.000MHZ-B2Y-T](#) [7A-10.000MBBK-T](#) [SG636PCE-20.000MC](#) [3404](#) [E1SAA18-25.000M TR](#) [CM315D32768EZFT](#) [C1E-24.000-7-2020-R](#) [C1E-19.200-12-1530-X-R](#) [C1E-16.000-12-1530-X-R](#) [ABM11-16.000MHZ-9-B1U-T](#) [FL5000014](#) [EUCA18-3.1872M](#) [FX0800015](#) [425F35E027M0000](#) [FP0800018](#)