

## PSE Technology Corporation

# SPECIFICATION FOR APPROVAL

CUSTOMER	
NOMINAL FREQUENCY	32.768 KHz
PRODUCT TYPE	<b>TYPE G8 SMD CRYSTAL</b>
SPEC. NO. ( P/N )	G83270023
CUSTOMER P/N	
ISSUE DATE	Jun.16,2016
VERSION	A

APPROVED	PREPARED	QA
<i>Brenda</i>	<i>Clair</i>	<i>Song Yang</i>
<b>APPROVED BY CUSTOMER :</b>		<b>AVL Status</b>
<b>Please return one copy with approval to PSE-TW</b>		

### PSE Technology Corporation

No.2, Tzu-Chiang 5th Rd, Chung Li Industrial Park,  
 Chung Li City, Taoyuan County, Taiwan (R.O.C.)  
 TEL: 886-3-451-8888  
 FAX: 886-3-461-3865  
<http://www.saronix-ecera.com.tw>

\*RoHS Compliant

# TYPE G8 SMD CRYSTAL

## G83270023

VER. A 16-Jun-16

### VERSION HISTORY

Version No.	Version Date	Customer Receipt Date	Supplier Receipt Date	Description	Notes
A	Jun.16,2016			Initial Release	



# TYPE G8 SMD CRYSTAL

G83270023

VER. A 16-Jun-16

## ELECTRICAL SPECIFICATIONS

SRe Part Number : G83270023

Parameters	Symbol	Specifications	Units	Notes
Nominal Frequency	Fn	32.768	KHz	
Frequency Tolerance	FT	± 20	ppm	at 25 °C ± 5 °C
Load Capacitance	CL	7	pF	Typ.
Drive Level	DL	0.1 / 0.5	µW	Typ. / Max.
Equivalent Series Resistance	ESR	70	KΩ	Max.
Temperature Coefficient	K	-0.03	ppm/°C <sup>2</sup>	± 0.01ppm/°C <sup>2</sup>
Operating Temperature Range	TR	-40 to 85	°C	
Shunt Capacitance	C0	1.5	pF	Typ.
Motional Capacitance	C1	6.5	fF	Typ.
Quality Factor	Q	13	K	Min.
Aging		± 3	ppm	Max. 1st year
Storage Temperature Range		-40 to 85	°C	
Insulation Resistance		500	MΩ	Min.

## Reliability ( Mechanical and environmental performances )

No.	Test Items	Conditions	Requirements
1	Bending test	Apply pressure in the direction of the arrow at a rate of about 0.5mm/s until bent width reaches 5mm, and hold for 30 seconds.	<ul style="list-style-type: none"><li>• Without mechanical damage such as breaks and satisfy sealing specification.</li><li>• Frequency change: Within ±5ppm</li><li>• Equivalent series resistance(E.S.R) change: Within 5kΩ</li></ul>
2	Shear test	Apply 20N(2.04kgf) static load to the core of quartz crystal units in the direction of the arrow using a R0.5 scratch tool, then hold for 5 seconds.	
3	Core body strength	Apply 10N(1.02kgf) static load to the quartz crystal units center in the direction of the arrow using a R0.5 pushing tool, then hold for 10 seconds.	
4	Vibration	Frequency sweep method shall be applied as follows. Quartz crystal units shall be vibrated with the sweeping frequency from 10Hz to 55Hz and return to 10Hz in 1 minute, with 1.5mm amplitude. This vibration shall be applied for 2 hours in each 3 perpendicular axes. Other procedures conform to JIS C 60068-2-6.	
5	Shock	Quartz crystal units shall be accelerated at 9810m/s <sup>2</sup> by 1ms pulse duration. This shock shall be applied 3 times in each 3 perpendicular axes. Other procedures conform to JIS C 60068-2-27.	

# TYPE G8 SMD CRYSTAL

**G83270023**

VER. A 16-Jun-16

6	Cold	Quartz crystal units shall be stored in the $-40\pm 3^{\circ}\text{C}$ atmosphere for 1000 hours. Other procedures conform to JIS C 60068-2-1.	<ul style="list-style-type: none"> <li>• Frequency change: Within <math>\pm 5\text{ppm}</math></li> <li>• Equivalent series resistance(E.S.R) change: Within <math>5\text{k}\Omega</math></li> </ul>														
7	Dry heat	Quartz crystal units shall be stored in the $100\pm 2^{\circ}\text{C}$ atmosphere for 100 hours. Other procedures conform to JIS C 60068-2-2.	<ul style="list-style-type: none"> <li>• After conditioning, quartz crystal units shall be subjected to standard atmospheric conditions for 1 hour, and measured.</li> </ul>														
8	Damp heat	Quartz crystal units shall be stored in the $40\pm 2^{\circ}\text{C}$ atmosphere with 90 to 95% relative humidity for 1000 hours. Other procedures conform to JIS C 60068-2-3.															
9	Change of temperature	Quartz crystal units shall be subjected successively 100 cycles of temperature change shown below. Other procedures conform to JIS C 0025.															
		<table border="1"> <thead> <tr> <th></th> <th>Temperature</th> <th>Duration</th> </tr> </thead> <tbody> <tr> <td>1</td> <td><math>-40\pm 3^{\circ}\text{C}</math></td> <td>30min.</td> </tr> <tr> <td>2</td> <td>Normal temperature</td> <td>Within 30 sec.</td> </tr> <tr> <td>3</td> <td><math>100\pm 2^{\circ}\text{C}</math></td> <td>30min.</td> </tr> <tr> <td>4</td> <td>Normal temperature</td> <td>Within 30 sec.</td> </tr> </tbody> </table>			Temperature	Duration	1	$-40\pm 3^{\circ}\text{C}$	30min.	2	Normal temperature	Within 30 sec.	3	$100\pm 2^{\circ}\text{C}$	30min.	4	Normal temperature
	Temperature	Duration															
1	$-40\pm 3^{\circ}\text{C}$	30min.															
2	Normal temperature	Within 30 sec.															
3	$100\pm 2^{\circ}\text{C}$	30min.															
4	Normal temperature	Within 30 sec.															
10	Sealing	Both the test methods specified below shall be applied.															
		Quartz crystal units shall be soaked in $90^{\circ}\text{C}$ or higher temperature hot water for 5 minutes.	<ul style="list-style-type: none"> <li>• Without repetitive leaking bubbles from quartz crystal units.</li> </ul>														
		Quartz crystal units shall be tested by Mass spectrometric leakage detector to measure the leakage rate of helium gas.	<ul style="list-style-type: none"> <li>• <math>1\times 10^{-9}\text{ Pa}\cdot\text{m}^3/\text{s}</math> or less</li> </ul>														
11	Aging	Quartz crystal units shall be stored in the $85\pm 3^{\circ}\text{C}$ atmosphere for $720\pm 12$ hours.	<ul style="list-style-type: none"> <li>• Frequency change: Within <math>\pm 5\text{ppm}</math></li> <li>• Equivalent series resistance(E.S.R) change: Within <math>5\text{k}\Omega</math></li> <li>• After conditioning, quartz crystal units shall be subjected to standard atmospheric conditions for 1 hour, and measured.</li> </ul>														
12	Solder-ability	Terminals coated with flux shall be immersed in the solder bath for $3.5\pm 0.5$ seconds.	<ul style="list-style-type: none"> <li>• Minimum 95% of immersed terminal shall be covered with new uniform solder.</li> </ul>														
		<table border="1"> <thead> <tr> <th></th> <th>Items</th> <th>Conditions</th> </tr> </thead> <tbody> <tr> <td>1</td> <td>Solder</td> <td>Sn-3.0Ag-0.5Cu</td> </tr> <tr> <td>2</td> <td>Flux</td> <td>Approximately 25wt% methanol(JIS K 8891) solution of resin(JIS K 5902).</td> </tr> <tr> <td>3</td> <td>Solder temperature</td> <td><math>245\pm 5^{\circ}\text{C}</math></td> </tr> </tbody> </table>			Items	Conditions	1	Solder	Sn-3.0Ag-0.5Cu	2	Flux	Approximately 25wt% methanol(JIS K 8891) solution of resin(JIS K 5902).	3	Solder temperature	$245\pm 5^{\circ}\text{C}$		
				Items	Conditions												
1	Solder	Sn-3.0Ag-0.5Cu															
2	Flux	Approximately 25wt% methanol(JIS K 8891) solution of resin(JIS K 5902).															
3	Solder temperature	$245\pm 5^{\circ}\text{C}$															

# TYPE G8 SMD CRYSTAL

G83270023

VER. A 16-Jun-16

<p>13</p> <p>Resistance to soldering heat</p>	<p>Reflow soldering method</p>	<p>Temperature profile</p> <p>Peak temperature: <math>260\pm 5^{\circ}\text{C}</math> for within 5seconds. Soldering temperature: <math>220^{\circ}\text{C}</math> or higher for <math>60\pm 10</math> seconds. Pre-heating temperature: <math>160\pm 10^{\circ}\text{C}</math> for <math>90\pm 10</math> seconds. Quartz crystal units which is put on PCB shall be through reflow soldering furnace twice with the condition shown above.</p>	<ul style="list-style-type: none"> <li>• Frequency change: Within <math>\pm 5\text{ppm}</math></li> <li>• Equivalent series resistance (E.S.R) change: Within <math>10\text{k}\Omega</math></li> <li>• After conditioning, quartz crystal units shall be subjected to standard atmospheric conditions for 1 hour, and measured.</li> <li>• Without distinct deformation in appearance.</li> </ul>
	<p>Hot Air method</p> <p>Apply hot air for <math>7\pm 0.5</math>seconds, distance 10mm, <math>300\pm 5^{\circ}\text{C}</math>, flow 10L/minutes</p>		<ul style="list-style-type: none"> <li>• Frequency change: Within <math>\pm 5\text{ppm}</math></li> <li>• Equivalent series resistance(E.S.R) change: Within <math>5\text{k}\Omega</math></li> <li>• After conditioning, quartz crystal units shall be subjected to standard atmospheric conditions for 1 hour, and measured.</li> <li>• Without distinct deformation in appearance.</li> </ul>
<p>14</p> <p>Solubility to resistance</p>	<p>Soak cleaning</p> <p>Quartz crystal units shall be soaked in isopropyl alcohol at normal temperature for 90 seconds.</p>		<ul style="list-style-type: none"> <li>• Without mechanical damage such as breaks and satisfy sealing specification.</li> <li>• Frequency change: Within <math>\pm 5\text{ppm}</math></li> <li>• Equivalent series resistance(E.S.R) change: Within <math>5\text{k}\Omega</math></li> <li>• Without distinct deformation in appearance.</li> <li>• Marking shall be legible.</li> </ul>

# TYPE G8 SMD CRYSTAL

G83270023

VER. A 16-Jun-16

## Marking

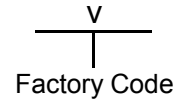
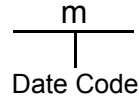

## Dimensions (Units: mm)

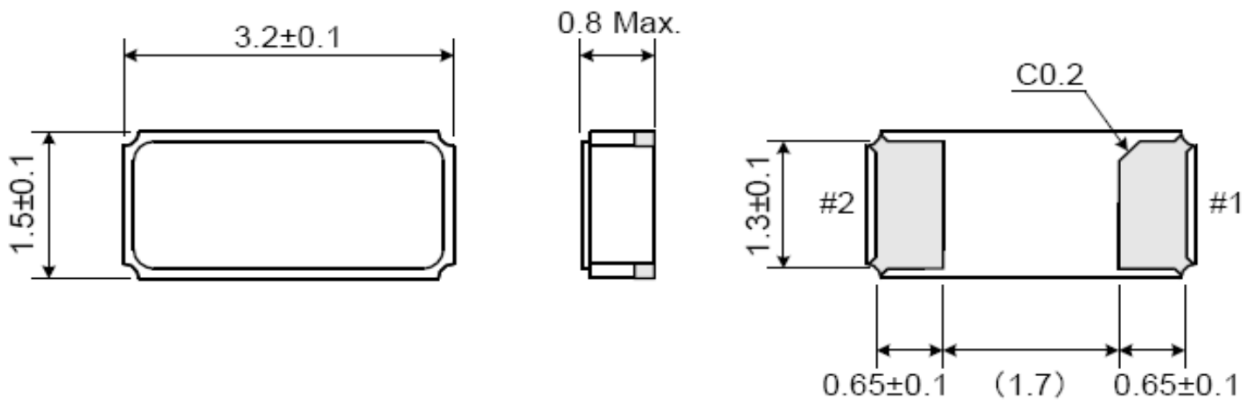

## Recommended Soldering Pattern

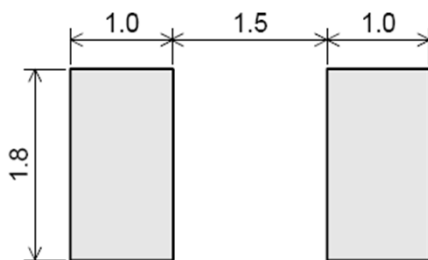

## Internal connection

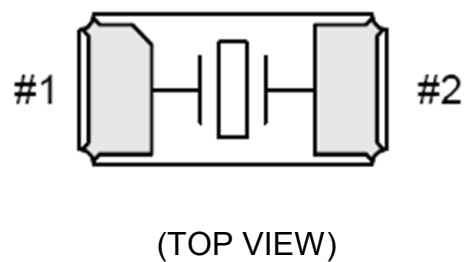

# TYPE G8 SMD CRYSTAL

G83270023

VER. A 16-Jun-16

## TAPING (Units: mm)

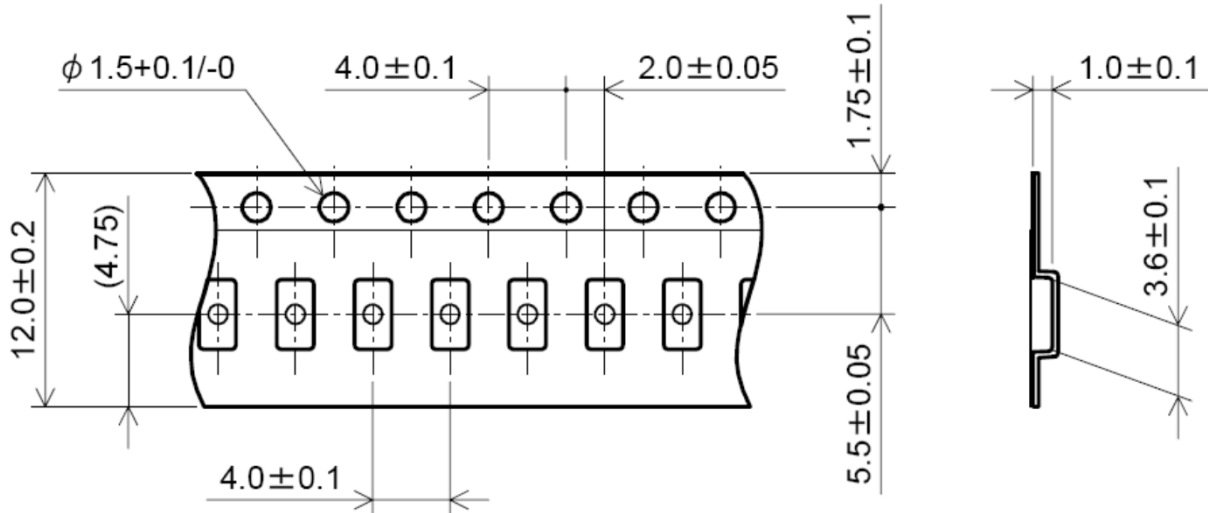

## REEL (Units: mm)

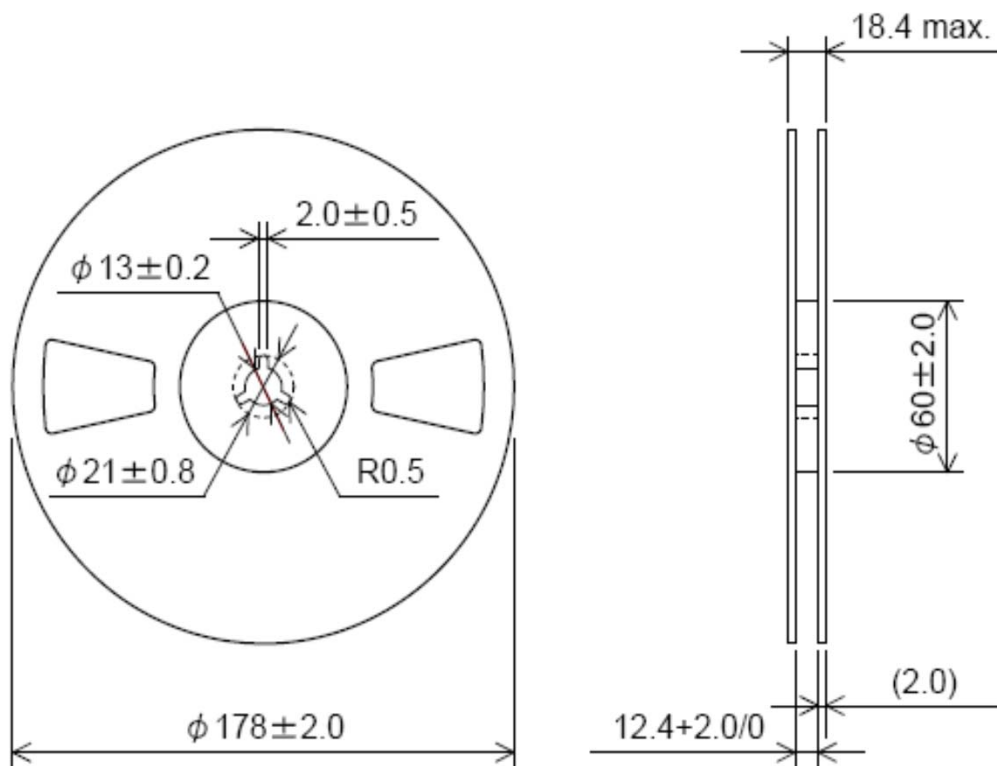

Quantity : 3000pcs / Reel

## X-ON Electronics

Largest Supplier of Electrical and Electronic Components

*Click to view similar products for [Crystals](#) category:*

*Click to view products by [Diodes Incorporated](#) manufacturer:*

Other Similar products are found below :

[MC405 32.0000K-R3:PURE SN](#) [7B-27.000MBBK-T](#) [MP1-8.0 99-BU](#) [9B-15.360MBBK-B](#) [PTX-A2JM-10.000M](#) [9C-7.680MBBK-T](#) [H10S-12.000-18-EXT-TR](#) [ABLS-18.432MHZ-20-D-4-T](#) [R38-32.768-12.5-5PPM-NPB](#) [BTD1062E05A-513](#) [21U15A-21.4MHZ](#) [RTX-781DF1-S-20.950](#) [LFXTAL066198Cutt](#) [9C-14.31818MBBK-T](#) [A-11.000MHZ-27](#) [ABM3B1-25.000MHZ-D2Y-T](#) [SPT2A-.032768B](#) [SPT2A.032768G](#) [SSPT7F-9PF20-R](#) [FX325BS-38.88EEM1201](#) [MP-1-25.000MHZ-3L](#) [MP-1-6.000MHZ](#) [LFXTAL065253Cutt](#) [LFXTAL066431Cutt](#) [XT9S20ANA14M7456](#) [XT9SNLANA16M](#) [646G-24-2](#) [7B-30.000MBBK-T](#) [9B-14.31818MBBK-B](#) [6504-202-1501](#) [6526-202-1501](#) [FA-118T](#) [27.1200MB50P-K0](#) [ABLS-12.000MHZ-B2Y-T](#) [BTJ120E02C](#) [SG636PCE-20.000MC](#) [3404](#) [CX3225SB48000Z0DZNC1](#) [CM315D32768EZFT](#) [C1E-24.000-7-2020-R](#) [C1E-19.200-12-1530-X-R](#) [C1E-16.000-12-1530-X-R](#) [FL5000014](#) [EUCA18-3.1872M](#) [425F35E027M0000](#) [FP0800018](#) [17196](#) [MS3V-T1R-32.768kHz-7pF-20PPM-TA-QC-Au](#) [VXM7-1C1-16M000](#) [MS1V-T1K-32.768kHz-10pF-20PPM-TA-QC-Au](#)