

Description

The PAM242x devices are high-performance, fixed frequency, current-mode PWM step-up DC/DC converters that incorporate internal power MOSFETs. The PAM242x includes an integrated power MOSFET that supports peak currents of up to 3A/4.5A/5.5A.

The PAM242x utilize simple external loop compensation allowing optimization between component size, cost, and AC performance across a wide range of applications. Additional functions include an externally programmable soft-start function for easy inrush current control, internal overvoltage protection (OVP), cycle-by-cycle current limit protection, undervoltage lock-out, and thermal shutdown.

The PAM242x are available in the small SO-8EP package.

Features

- Greater than 90% Efficiency
- Adjustable Output Voltage Up to 24V
- Internal 24V Power MOSFET
- Peak Current 3A, 4.5A, 5.5A
- 520kHz Frequency
- Built-In Overvoltage Protection (OVP)
- Open Protection
- Programmable Soft-Start Function
- Thermal Shutdowns
- Undervoltage Lockout
- Overcurrent Protection
- **Totally Lead-Free & Fully RoHS Compliant (Notes 1 & 2)**
- **Halogen and Antimony Free. "Green" Device (Note 3)**
- **For automotive applications requiring specific change control (i.e. parts qualified to AEC-Q100/101/200, PPAP capable, and manufactured in IATF 16949 certified facilities), please [contact us](#) or your local Diodes representative.**

<https://www.diodes.com/quality/product-definitions/>

- Notes:
1. No purposely added lead. Fully EU Directive 2002/95/EC (RoHS), 2011/65/EU (RoHS 2) & 2015/863/EU (RoHS 3) compliant.
 2. See <https://www.diodes.com/quality/lead-free/> for more information about Diodes Incorporated's definitions of Halogen- and Antimony-free, "Green" and Lead-free.
 3. Halogen- and Antimony-free "Green" products are defined as those which contain <900ppm bromine, <900ppm chlorine (<1500ppm total Br + Cl) and <1000ppm antimony compounds.

Pin Assignments

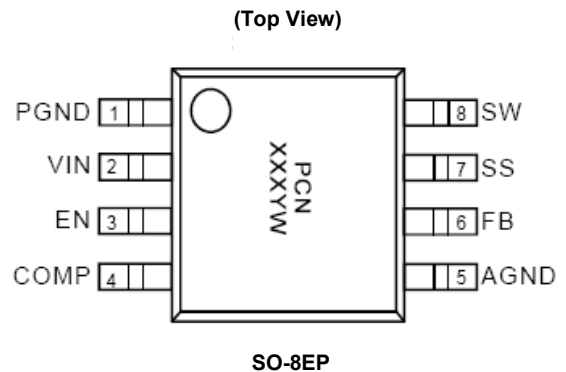

Applications

- TFT LCD Monitors
- Battery-Powered Equipment
- Set-Top Boxes
- DSL and Cable Modems and Routers

Typical Applications Circuit

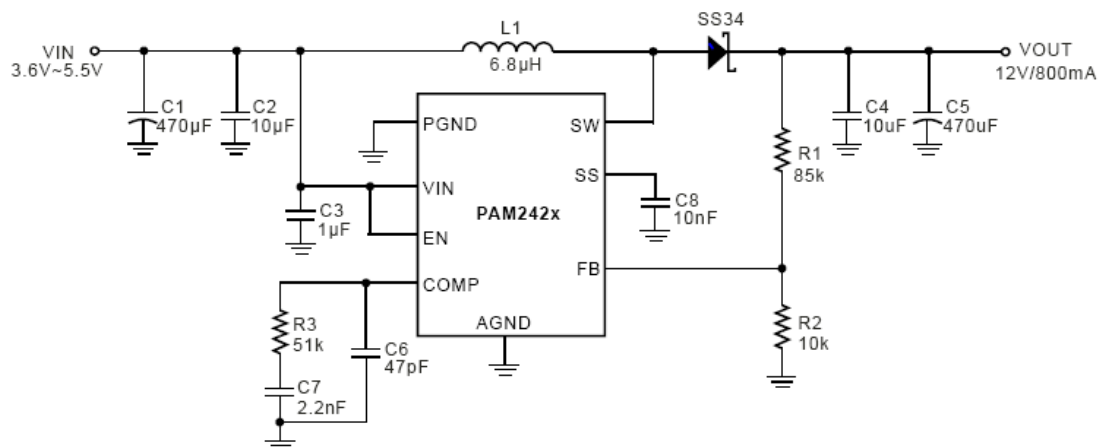

Pin Descriptions

Pin Number	SO-8EP Pin Name	Function
1	PGND	Power Ground
2	VIN	Supply Input
3	EN	Enable Control. Connect to a logic high level to enable the IC. Connect to a logic low level to disable the IC. When unused, connect EN pin to VIN (do not leave pin floating).
4	COMP	Error Amplifier Compensation Node
5	AGND	Analog Ground
6	FB	Feedback Input. Connect this pin a resistor divider from the output to set the output voltage. FB is regulated to 1.262V.
7	SS	Soft Start Control Input. Connect a capacitor from this pin to Ground to set soft-start timing duration. SS is discharged to ground in shutdown. SS may be left unconnected if soft start is not desired.
8	SW	Switch Output. Connect this pin to the inductor and the Schottky diode. To minimize EMI, minimize the PCB trace path between this pin and the input bypass capacitor.
—	Exposed Pad	Connected to Ground

Functional Block Diagram

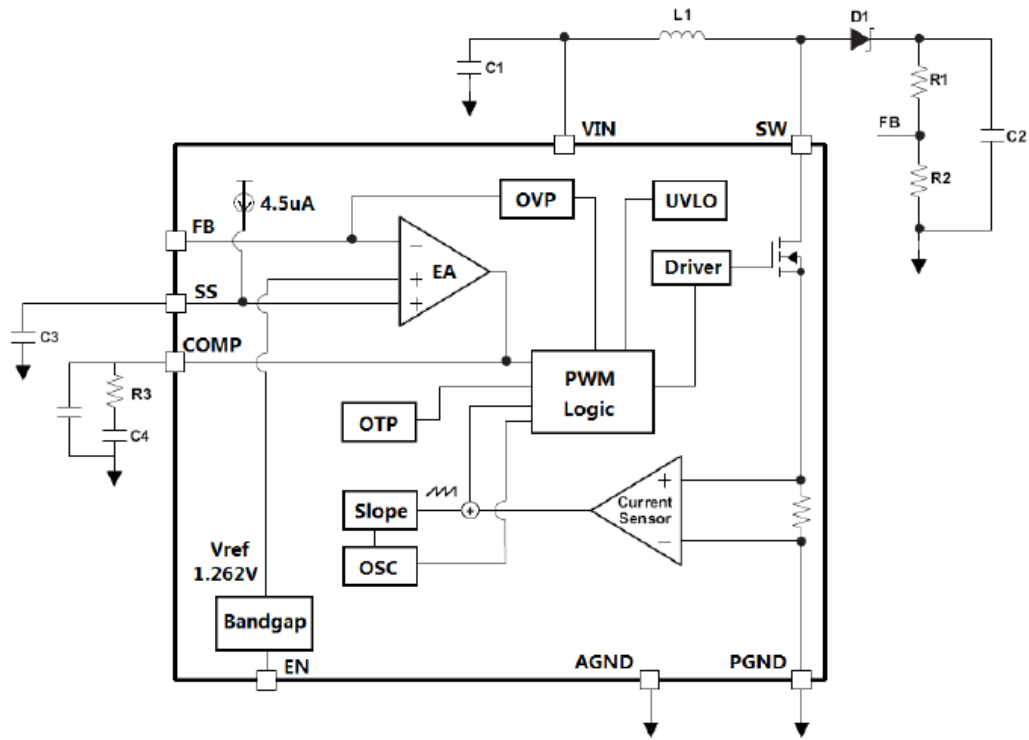

Absolute Maximum Ratings (@ T_A = +25°C, unless otherwise specified.)

These are stress ratings only and functional operation is not implied. Exposure to absolute maximum ratings for prolonged time periods may affect device reliability. All voltages are with respect to ground.

Parameter	Rating	Unit
SW to Ground	-0.3 to +28	V
V _{IN} , EN, FB, SS, COMP to Ground	-0.3 to +6.5	V
Continuous SW Current	Internally Limited	A
Operating Temperature Range	-40 to +150	°C
Storage Temperature Range	-55 to +150	°C
Lead Temperature (Soldering, 10s)	300	°C

Recommended Operating Conditions (@ T_A = +25°C, unless otherwise specified.)

Parameter	Rating	Unit
Junction Temperature Range	-40 to +125	°C
Ambient Temperature Range	-40 to +85	

Thermal Information

Parameter	Symbol	Package	Max	Unit
Thermal Resistance (Junction to Case)	θ _{JC}	SO-8EP	75	°C/W
Thermal Resistance (Junction to Ambient)	θ _{JA}	SO-8EP	180	

Electrical Characteristics (@ T_A = +25°C, V_{IN} = V_{EN} = 5V, unless otherwise specified.)

Parameter	Test Conditions	Min	Typ	Max	Unit	
Input Voltage	—	2.7	—	5.5	V	
Undervoltage Lockout Threshold	V _{IN} Rising	—	2.5	—	V	
Undervoltage Lockout Hysteresis	—	—	200	—	mV	
Quiescent Supply	V _{FB} = 1.4V, Not Switching	—	0.25	0.35	mA	
	V _{FB} = 1.0V, Switching	—	3	5		
Supply Current in Shutdown	EN = Ground	—	0.1	1.0	µA	
Switching Frequency	—	—	520	—	kHz	
Maximum Duty Cycle	—	85	—	—	%	
FB Feedback Voltage	—	1.230	1.262	1.294	V	
FB Input Current	—	—	0	80	nA	
FB Voltage Line Regulation	V _{FB} from 2.7V to 5.5V	—	0.05	0.15	%/V	
Switch Current Limit	PAM2421	V _{IN} = 3.2V Duty Cycle = 70%	3	—	—	A
	PAM2422		4.5	—	—	
	PAM2423		5.5	—	—	
Switching On Resistance	PAM2421	—	130	—	mΩ	
	PAM2422	—	100	—		
	PAM2423	—	70	—		
Switch Leakage Current	V _{SW} = 10V, EN = Ground	—	—	15	µA	
Soft-Start Pin Bias Current	V _{SS} = 1.2V	2.0	4.5	7.0	µA	
Logic High Threshold	EN Pin	1.4	—	—	V	
Logic Low Threshold	EN Pin	—	—	0.4	V	
EN Pull Down Resistor	—	—	1	—	mΩ	
Thermal Shutdown Temperature	—	—	+160	—	°C	
Thermal Shutdown Hysteresis	—	—	+40	—	°C	

Typical Operating Characteristics (@ $T_A = +25^\circ\text{C}$, $V_{IN} = V_{EN} = 5\text{V}$, $V_{FREQ} = 0$, unless otherwise specified.)

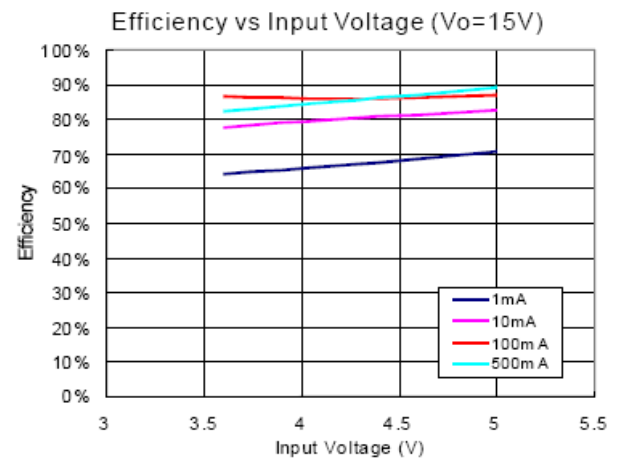
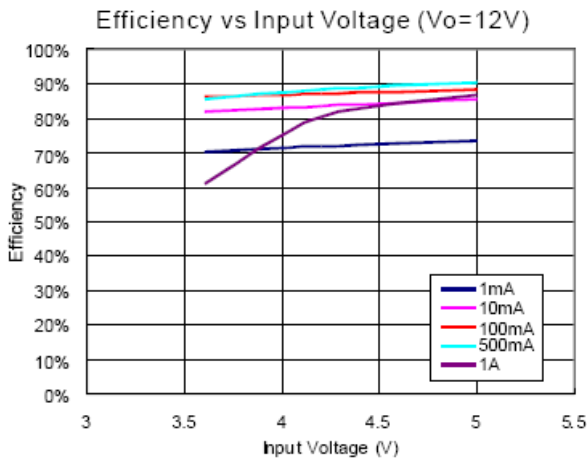
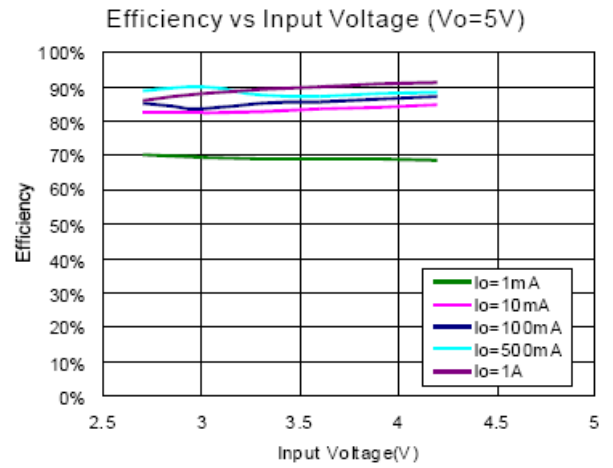
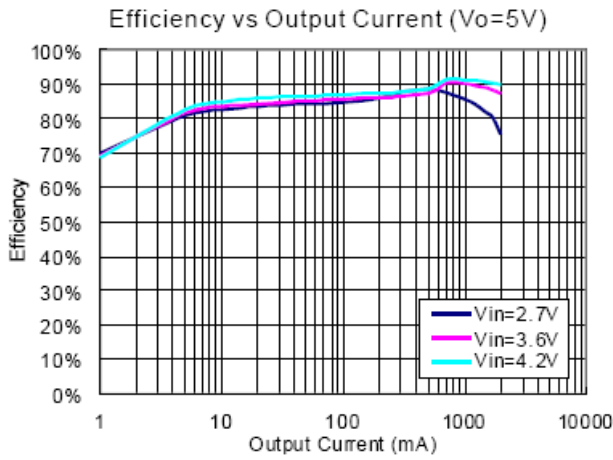
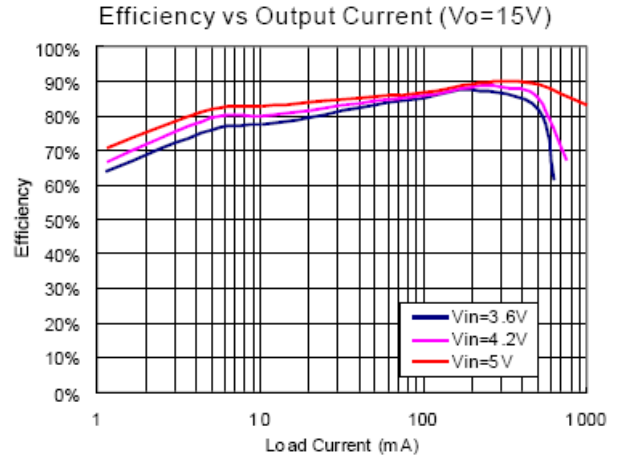
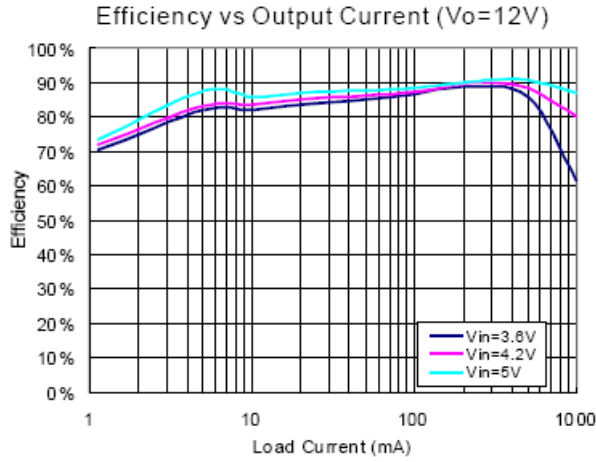

Typical Performance Characteristics (@ $T_A = +25^\circ\text{C}$, $V_{IN} = V_{EN} = 5\text{V}$, $V_{FREQ} = 0$, unless otherwise specified.) (continued)

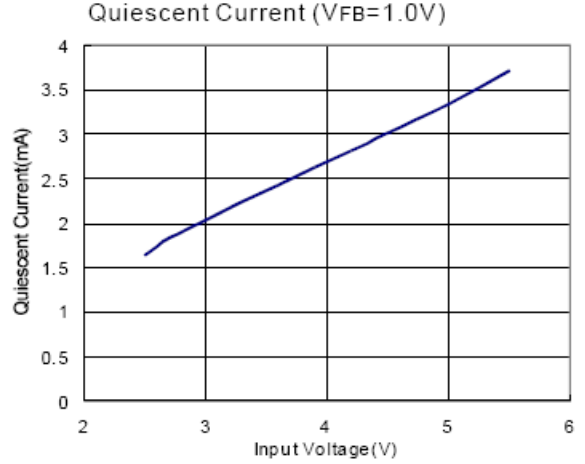
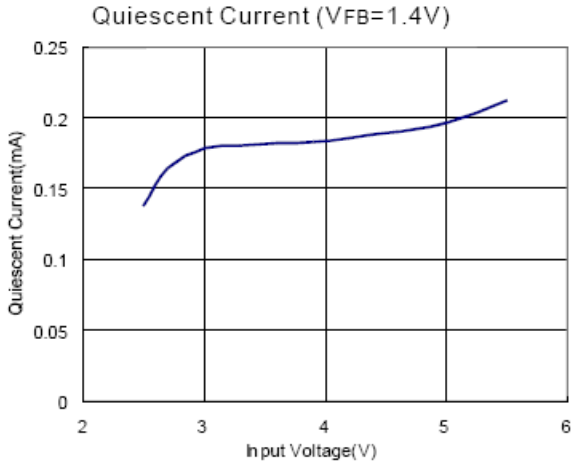
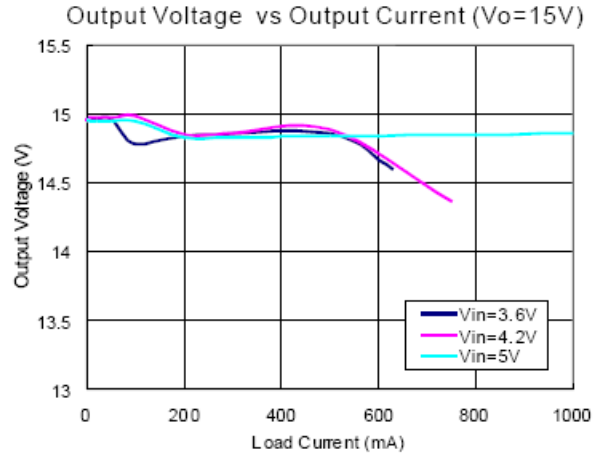
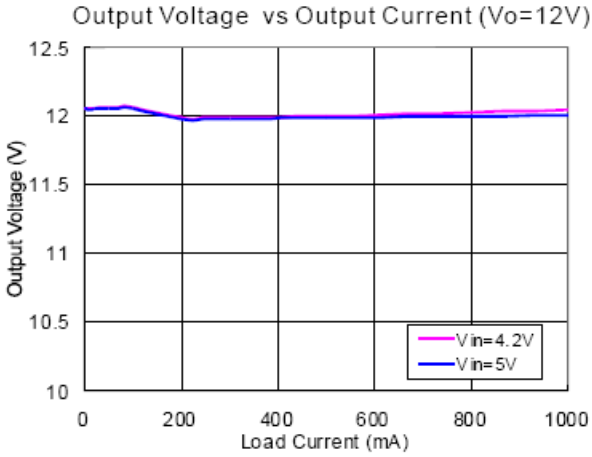

Application Information

The PAM242x are highly efficient step-up DC/DC converters that employ a current mode, fixed frequency pulse-width modulation (PWM) architecture with excellent line and load regulation. The PAM242x operate at constant switching frequency under medium to high load current conditions. At light loads, these devices operate in a pulse-skipping mode in order to improve light-load efficiency.

Soft-Start

The PAM242x offer a programmable soft-start function, which minimizes inrush current during startup. The soft-start period is programmed by connecting a 10nF capacitor between SS and Ground. Operation of the soft-start function is as follows: when the IC is disabled, SS is actively discharged to Ground. Upon enabling the IC, CSS is charged with a 4.5µA current so that the voltage at SS increases in a controlled manner. The peak inductor current is limited by the voltage at SS, so that the input current is limited until the soft-start period expires, and the regulator can achieve its full output current rating.

Setting the Output Voltage

The PAM242x feature external adjustable output voltages of up to 24V. To program the output voltage, simply connect a resistive voltage divider between the output, FB, and GND, with resistors set according to the following equation:

$$R1 = R2 \times \left[\left(\frac{V_{OUT}}{V_{FB}} \right) - 1 \right]$$

Where V_{FB} is 1.262V.

Rectifier Selection

For optimal performance, the rectifier should be a Schottky rectifier that is rated to handle both the output voltage as well as the peak switch current.

Open Voltage Protection

The PAM242x features internal automatic overvoltage protection, when feedback voltage is higher than 115%.

Open Protection

Once the outputs achieve regulation, the controller will automatically disable if the voltage at FB falls below 0.2V. This prevents the controller from running open-loop and potentially damaging the IC and load.

Shutdown

Drive EN low to disable the IC and reduce the supply current to just 0.1µA. As with all nonsynchronous step-up DC/DC converters, the external Schottky diode provides a DC path from the input to the output in shutdown. As a result, the output drops to one diode voltage drop below the input in shutdown.

The PAM242x both feature integrated thermal overload protection. Both devices are automatically disabled when their junction temperatures exceed +160°C, and automatically re-enable when the die temperature decreases by +40°C.

Ordering Information

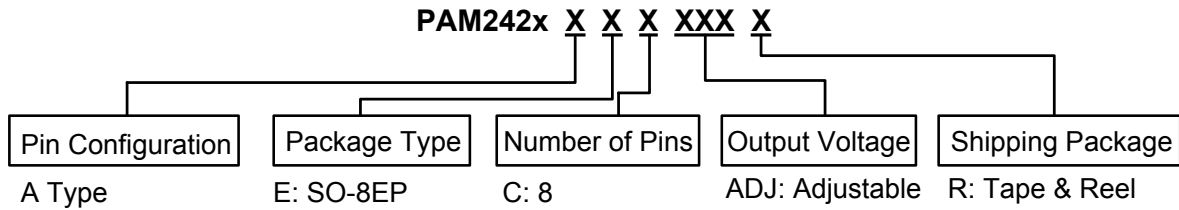

Part Number	Peak Current	Package Type	Standard Package	Status (Note 4)
PAM2421AECADJR	3A	SO-8EP	2500 Units/Tape & Reel	NRND
PAM2422AECADJR	4.5A	SO-8EP	2500 Units/Tape & Reel	EOL
PAM2423AECADJR	5.5A	SO-8EP	2500 Units/Tape & Reel	Active

Notes: 4. PAM2423AECADJR is Active. All other versions are NRND or EOL. For recommended alternatives to NRND/EOL devices, contact us at <https://www.diodes.com/about/contact-us/>.
 5. For packaging details, go to our website at <https://www.diodes.com/design/support/packaging/diodes-packaging/>.

Marking Information

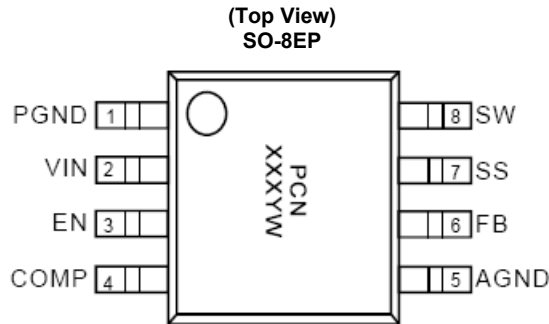

PCN : Product Code of PAM242x
 XXX : Internal Code
 Y : Year 0~9
 W : Week: A~Z: 1~26 weeks;
 a~z: 27~52 weeks;
 z represents 52 and 53 weeks

Package Outline Dimensions

Please see <http://www.diodes.com/package-outlines.html> for the latest version.

SO-8EP

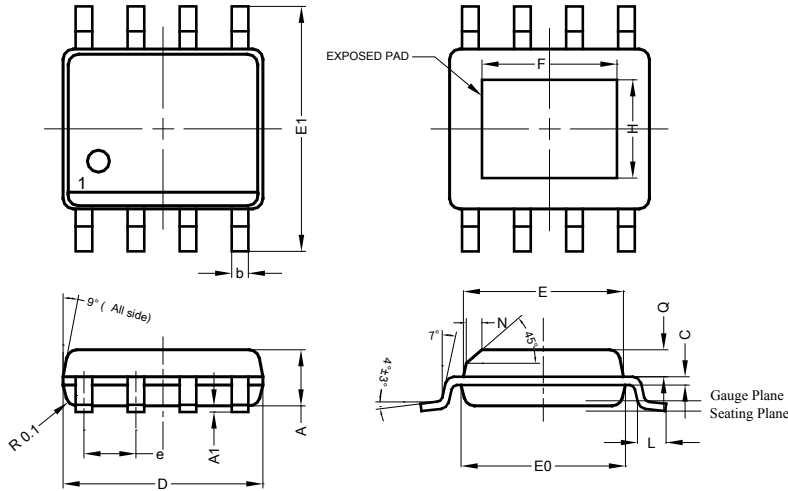

SO-8EP			
Dim	Min	Max	Typ
A	1.40	1.50	1.45
A1	0.00	0.13	-
b	0.30	0.50	0.40
C	0.15	0.25	0.20
D	4.85	4.95	4.90
E	3.80	3.90	3.85
E0	3.85	3.95	3.90
E1	5.90	6.10	6.00
e	-	-	1.27
F	2.75	3.35	3.05
H	2.11	2.71	2.41
L	0.62	0.82	0.72
N	-	-	0.35
Q	0.60	0.70	0.65
All Dimensions in mm			

Suggested Pad Layout

Please see <http://www.diodes.com/package-outlines.html> for the latest version.

SO-8EP

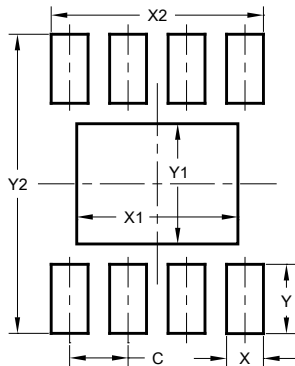

Dimensions	Value (in mm)
C	1.270
X	0.802
X1	3.502
X2	4.612
Y	1.505
Y1	2.613
Y2	6.500

Mechanical Data

- Moisture Sensitivity: Level 1 per J-STD-020
- Terminals: Finish Matte Tin Plated Leads, Solderable per MIL-STD-202, Method 208 (e3)
- Weight: 0.081 grams (Approximate)

IMPORTANT NOTICE

1. DIODES INCORPORATED AND ITS SUBSIDIARIES (“DIODES”) MAKE NO WARRANTY OF ANY KIND, EXPRESS OR IMPLIED, WITH REGARDS TO ANY INFORMATION CONTAINED IN THIS DOCUMENT, INCLUDING, BUT NOT LIMITED TO, THE IMPLIED WARRANTIES OF MERCHANTABILITY, FITNESS FOR A PARTICULAR PURPOSE OR NON-INFRINGEMENT OF THIRD PARTY INTELLECTUAL PROPERTY RIGHTS (AND THEIR EQUIVALENTS UNDER THE LAWS OF ANY JURISDICTION).
2. The Information contained herein is for informational purpose only and is provided only to illustrate the operation of Diodes products described herein and application examples. Diodes does not assume any liability arising out of the application or use of this document or any product described herein. This document is intended for skilled and technically trained engineering customers and users who design with Diodes products. Diodes products may be used to facilitate safety-related applications; however, in all instances customers and users are responsible for (a) selecting the appropriate Diodes products for their applications, (b) evaluating the suitability of the Diodes products for their intended applications, (c) ensuring their applications, which incorporate Diodes products, comply the applicable legal and regulatory requirements as well as safety and functional-safety related standards, and (d) ensuring they design with appropriate safeguards (including testing, validation, quality control techniques, redundancy, malfunction prevention, and appropriate treatment for aging degradation) to minimize the risks associated with their applications.
3. Diodes assumes no liability for any application-related information, support, assistance or feedback that may be provided by Diodes from time to time. Any customer or user of this document or products described herein will assume all risks and liabilities associated with such use, and will hold Diodes and all companies whose products are represented herein or on Diodes’ websites, harmless against all damages and liabilities.
4. Products described herein may be covered by one or more United States, international or foreign patents and pending patent applications. Product names and markings noted herein may also be covered by one or more United States, international or foreign trademarks and trademark applications. Diodes does not convey any license under any of its intellectual property rights or the rights of any third parties (including third parties whose products and services may be described in this document or on Diodes’ website) under this document.
5. Diodes products are provided subject to Diodes’ Standard Terms and Conditions of Sale (<https://www.diodes.com/about/company/terms-and-conditions/terms-and-conditions-of-sales/>) or other applicable terms. This document does not alter or expand the applicable warranties provided by Diodes. Diodes does not warrant or accept any liability whatsoever in respect of any products purchased through unauthorized sales channel.
6. Diodes products and technology may not be used for or incorporated into any products or systems whose manufacture, use or sale is prohibited under any applicable laws and regulations. Should customers or users use Diodes products in contravention of any applicable laws or regulations, or for any unintended or unauthorized application, customers and users will (a) be solely responsible for any damages, losses or penalties arising in connection therewith or as a result thereof, and (b) indemnify and hold Diodes and its representatives and agents harmless against any and all claims, damages, expenses, and attorney fees arising out of, directly or indirectly, any claim relating to any noncompliance with the applicable laws and regulations, as well as any unintended or unauthorized application.
7. While efforts have been made to ensure the information contained in this document is accurate, complete and current, it may contain technical inaccuracies, omissions and typographical errors. Diodes does not warrant that information contained in this document is error-free and Diodes is under no obligation to update or otherwise correct this information. Notwithstanding the foregoing, Diodes reserves the right to make modifications, enhancements, improvements, corrections or other changes without further notice to this document and any product described herein. This document is written in English but may be translated into multiple languages for reference. Only the English version of this document is the final and determinative format released by Diodes.
8. Any unauthorized copying, modification, distribution, transmission, display or other use of this document (or any portion hereof) is prohibited. Diodes assumes no responsibility for any losses incurred by the customers or users or any third parties arising from any such unauthorized use.

Copyright © 2021 Diodes Incorporated

www.diodes.com

X-ON Electronics

Largest Supplier of Electrical and Electronic Components

Click to view similar products for [Power Management IC Development Tools](#) *category:*

Click to view products by [Diodes Incorporated](#) *manufacturer:*

Other Similar products are found below :

[EVB-EP5348UI](#) [BQ25010EVM](#) [ISL80019AEVAL1Z](#) [ISLUSBI2CKIT1Z](#) [ISL8002AEVAL1Z](#) [ISL91108IIA-EVZ](#) [ISL28022EVKIT1Z](#)
[STEVAL-ISA008V1](#) [DRI0043](#) [NCP10671B05GEVB](#) [EVB-EN6337QA](#) [SAMPLEBOXILD8150TOBO1](#) [AP61100Z6-EVM](#) [AP62300WU-](#)
[EVM](#) [KITA2GTC387MOTORCTRTOBO1](#) [AEK-MOT-TK200G1](#) [EVLONE65W](#) [STEVAL-ILH006V1](#) [STEVAL-IPE008V2](#) [STEVAL-](#)
[IPP001V2](#) [STEVAL-ISA013V1](#) [STEVAL-ISA067V1](#) [STEVAL-ISQ002V1](#) [TPS2306EVM-001](#) [TPS2330EVM-185](#) [TPS40001EVM-001](#)
[SECO-HVDCDC1362-15W-GEVB](#) [BTS7030-2EPA](#) [LTC3308AIV#WTRPBF](#) [TLT807B0EPV](#) [BTS71033-6ESA](#) [EV13N91A](#) [EV55W64A](#)
[Si8285_86v2-KIT](#) [NCP-NCV51752D2PAK3LGEVB](#) [ISL81807EVAL1Z](#) [EVALM7HVIGBTPFCINV4TOBO1](#) [903-0300-000](#) [903-0301-000](#)
[ROA1286023/1](#) [REFSHA35IMD111TSYSTOBO1](#) [150037482](#) [SABMB629](#) [TDINV3000W50B-KIT](#) [NCP1681CCM1KWGEVB](#) [I7C08A-](#)
[CC3-EVK-P2](#) [I7C12A-CC3-EVK-P2](#) [i7C20A-CC3-EVK-P2](#) [RTK9754L27S01000BE](#) [APEK89303KET-01-T](#)