

## Description

The PAM8904 is a piezo sounder driver with integrated charge pump boost converter. The PAM8904 is capable of driving a ceramic/piezo sounder with 24V<sub>PP</sub> from a 5.5V power supply. The charge pump can operate in either a 1x, 2x or 3x mode.

The boost converter operates at a fixed frequency of 1.0MHz and provides a 12V output with a minimum number of external components. The PAM8904 can drive up to 15nF loading. Diodes Incorporated's unique drive technology provides a small inrush current, low EMI and high efficiency.

The PAM8904 includes built-in automatic shutdown and wake up that guarantees longer battery life. The PAM8904 features thermal shutdown, over current protection, over voltage protection and under voltage lock-out.

The PAM8904 is available in a 16-pin U-QFN3030-16 (Type B) package, or 12-pin U-QFN3030-12 (Type A) package.

## Features

- Supply Voltage Range from 2.3V to 5.5V
- 18V<sub>PP</sub> Output from a 3V Supply
- Integrated Boost Converter Generates up to 12V Supply
- Input Signal 20Hz to 300kHz
- No Voltage Cross Output at Shutdown Mode
- Low Current Consumption
- Automatic Standby and Wake-up Control
- Available in Space Saving Packages 16 Pin U-QFN3030-16 (Type B) or 12 Pin U-QFN3030-12 (Type A) Package
- **Totally Lead-Free & Fully RoHS Compliant (Notes 1 & 2)**
- **Halogen and Antimony Free. "Green" Device (Note 3)**
- **For automotive applications requiring specific change control (i.e. parts qualified to AEC-Q100/101/200, PPAP capable, and manufactured in IATF 16949 certified facilities), please [contact us](#) or your local Diodes representative. <https://www.diodes.com/quality/product-definitions/>**
- **An Automotive-Compliant Part is Available Under Separate Datasheet ([PAM8904Q](#))**

- Notes:
1. No purposely added lead. Fully EU Directive 2002/95/EC (RoHS), 2011/65/EU (RoHS 2) & 2015/863/EU (RoHS 3) compliant.
  2. See <https://www.diodes.com/quality/lead-free/> for more information about Diodes Incorporated's definitions of Halogen- and Antimony-free, "Green" and Lead-free.
  3. Halogen- and Antimony-free "Green" products are defined as those which contain <900ppm bromine, <900ppm chlorine (<1500ppm total Br + Cl) and <1000ppm antimony compounds.

## Pin Assignments

(Top View)

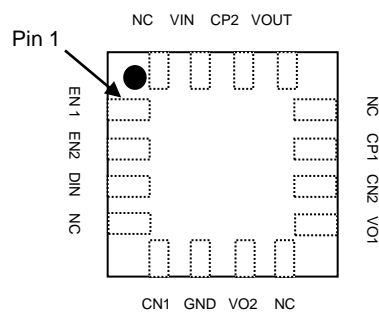

**U-QFN3030-16 (Type B)**

(Top View)

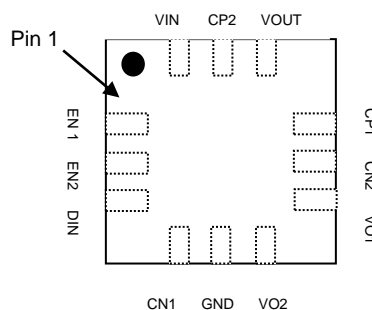

**U-QFN3030-12 (Type A)**

## Applications

- Health Care Systems
- Alarm Clocks
- Security Devices
- Home Appliances

**Typical Applications Circuit**

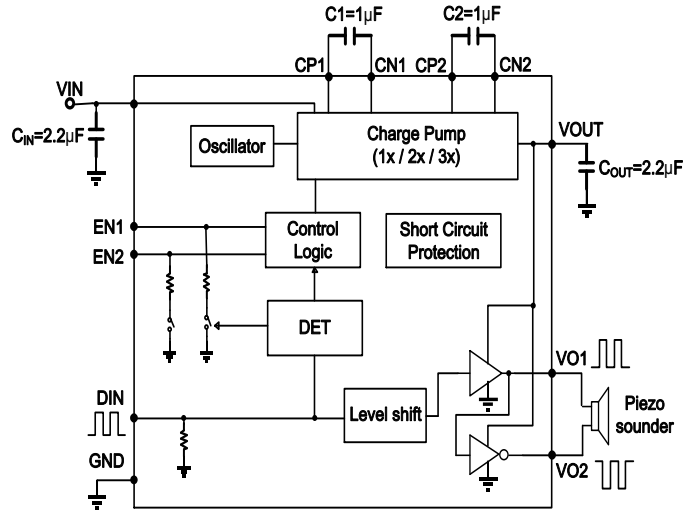

**Pin Descriptions**

Pin Number		Pin Name	I/O/P	Function
U-QFN3030-16 (Type B)	U-QFN3030-12 (Type A)			
1	1	EN1	I	Charge pump mode select 1
2	2	EN2	I	Charge pump mode select 2
3	3	DIN	I	Signal Input
4	—	NC	—	No Connection
5	4	CN1	I	Capacitor 1 Negative Terminal
6	5	GND	P	Ground
7	6	VO2	O	Positive Output
8	—	NC	—	No Connection
9	7	VO1	O	Negative Output
10	8	CN2	I	Capacitor 2 Negative Terminal
11	9	CP1	I	Capacitor 1 Positive Terminal
12	—	NC	—	No Connection
13	10	VOOUT	O	Boost Output
14	11	CP2	I	Capacitor 2 Positive Terminal
15	12	VIN	P	Power Supply
16	—	NC	—	No Connection

### Absolute Maximum Ratings (@ $T_A = +25^\circ\text{C}$ , unless otherwise specified.)

Symbol	Characteristics	Value	Unit
$V_{IN}$	Supply Voltage	-0.3 to +6.0	V
$V_{OUT}$	Output Voltage	15	V
$V_{EN1}, V_{EN2}$	EN1, EN2 Voltage	GND -0.3 to $V_{IN} + 0.3$	V
$T_A$	Operating Free-Air Temperature Range	-40 to +85	$^\circ\text{C}$
$T_J$	Operating Junction Temperature Range	-40 to +150	$^\circ\text{C}$
$T_{STG}$	Storage Temperature Range	-65 to +150	$^\circ\text{C}$

### Recommended Operating Conditions (@ $T_A = +25^\circ\text{C}$ , unless otherwise specified.)

Symbol	Characteristics	Min	Max	Unit	
$V_{IN}$	Supply Voltage	—	2.3	5.5	V
$V_{IH}$	High-Level Input Voltage	EN1, EN2	1.2 to $V_{IN} + 0.3$		V
$V_{IL}$	Low-Level Input Voltage	EN1, EN2	-0.3	+0.4	V
$T_A$	Operating Free-Air Temperature	-40	+85	$^\circ\text{C}$	

### Thermal Information

Parameter	Symbol	Package	Maximum	Unit
Thermal Resistance (Junction to Ambient)	$\theta_{JA}$	U-QFN3030-16 (Type B) U-QFN3030-12 (Type A)	35	$^\circ\text{C/W}$
Thermal Resistance (Junction to Case)	$\theta_{JC}$	U-QFN3030-16 (Type B) U-QFN3030-12 (Type A)	14	$^\circ\text{C/W}$

**Electrical Characteristics** (@ $T_A = +25^\circ\text{C}$ ,  $V_{IN} = 3.0\text{V}$ ,  $C_{PIEZO} = 15\text{nF}$ ,  $f_{DIN} = 4\text{kHz}$ , unless otherwise specified.)

Parameter	Symbol	Conditions	Min	Typ	Max	Unit
Output Voltage Range	$V_{OUT}$	(Note 4)	2.1	—	12	V
Output Voltage	$V_{OUT1}$	1x Mode	2.8	—	3	V
	$V_{OUT2}$	2x Mode	5.2	—	6	V
	$V_{OUT3}$	3x Mode (Note 5)	7.2	—	9	V
Operating Current 1	$I_{DD11}$	1x Mode, $C_{PIEZO} = \text{No Load}$	—	50	—	$\mu\text{A}$
	$I_{DD12}$	2x Mode, $C_{PIEZO} = \text{No Load}$	—	720	—	$\mu\text{A}$
	$I_{DD13}$	3x Mode, $C_{PIEZO} = \text{No Load}$	—	1,700	—	$\mu\text{A}$
Operating Current 2	$I_{DD21}$	1x Mode, Single-ended application	—	0.3	—	mA
	$I_{DD22}$	2x Mode, Single-ended application	—	1.4	—	mA
	$I_{DD23}$	3x Mode, Single-ended application	—	3.9	—	mA
Operating Current 3	$I_{DD31}$	1x Mode, Differential application	—	0.9	—	mA
	$I_{DD32}$	2x Mode, Differential application	—	3.6	—	mA
	$I_{DD33}$	3x Mode, Differential application	—	7.9	—	mA
Shutdown Current	$I_{SD}$	$DIN = 0\text{V}$	—	—	1	$\mu\text{A}$
Input Frequency	$f_{IN}$	Rectangular pulse	—	4	—	kHz
Oscillating Frequency	$f_{OSC}$	—	—	1	—	MHz
VOUT Start Delay Time	$t_{ON1}$	1x Mode, From DIN signal High to 90% $V_{OUT}$ steady state	—	270	—	$\mu\text{s}$
	$t_{ON2}$	2x Mode, From DIN signal High to 90% $V_{OUT}$ steady state	—	320	—	$\mu\text{s}$
	$t_{ON3}$	3x Mode From DIN signal High to 90% $V_{OUT}$ steady state	—	350	—	$\mu\text{s}$
Shutdown Delay Time	$t_{OFF}$	$DIN = H \rightarrow L$	—	42	—	ms
Output Short-Circuit Current	$I_{SC}$	—	—	40	—	mA
Control Terminal Voltage H	$V_{IH}$	EN1, EN2, DIN pins	$0.8 \cdot V_{IN}$	—	$V_{IN}$	V
Control Terminal Voltage L	$V_{IL}$	EN1, EN2, DIN pins	0	—	$0.2 \cdot V_{IN}$	V
Control Terminal Current 1	$I_{IH1}$	$DIN = 3\text{V}$	—	—	1	$\mu\text{A}$
Control Terminal Current 2	$I_{IH2}$	$V_{EN1}, V_{EN2} = 3\text{V}, DIN = 3\text{V}$	—	—	1	$\mu\text{A}$
Control Terminal Current 3	$I_{IH3}$	$V_{EN1}, V_{EN2} = 3\text{V}, DIN = 0\text{V}$	—	—	1	$\mu\text{A}$

- Notes:
- It is possible to drive  $V_{OUT}$ ,  $VO1$  and  $VO2$  to  $3x V_{DD}$ . A supply voltage of 4V or more should not be used in 3x mode as this will exceed the maximum output voltage rating.
  - When designed under 3x mode, it should be carefully noted that the  $V_{OUT}$  absolute maximum value should not exceed 15V.

## Application Information

### Charge Pump Mode Setting

The Charge Pump Mode (CPM) pins EN1 and EN2 are used to set the charge pump into mode 1x V<sub>DD</sub>, 2x V<sub>DD</sub>, 3x V<sub>DD</sub> or they can be used to put the PAM8904 in to a forced low current shutdown mode.

DIN	EN1	EN2	MODE
0	—	—	Shutdown Mode
1	0	0	Shutdown Mode
1	0	1	1x Mode
1	1	0	2x Mode
1	1	1	3x Mode

Care must be taken when using the 3x mode with a V<sub>DD</sub> supply of 5V or more, as this will force the V<sub>OUT</sub> to exceed its Absolute Maximum specification (15V).

V <sub>DD</sub> Range	Mode
2.3V to 5.5V	1x, 2x and 3x

### Timing Chart and Device Operation

When one or both of the EN pins are pulled high, the device enters normal operation mode, refer to the above table for the mode selection. Once the PAM8904 senses a valid signal on the DIN pin, the charge pump will start and provide the desired voltage on the V<sub>OUT</sub> pin and the output drive VO1 and VO2 start to function after time t<sub>ON</sub> which is typically between 270μs and 350μs depending on the mode chosen. Once the input signal on DIN is removed, the PAM8904 senses this and waits typically 42ms to ensure the signal has been removed. If there is no further valid signal within the time period t<sub>OFF</sub>, the PAM8904 enters into a low current standby mode.

### Timing Chart

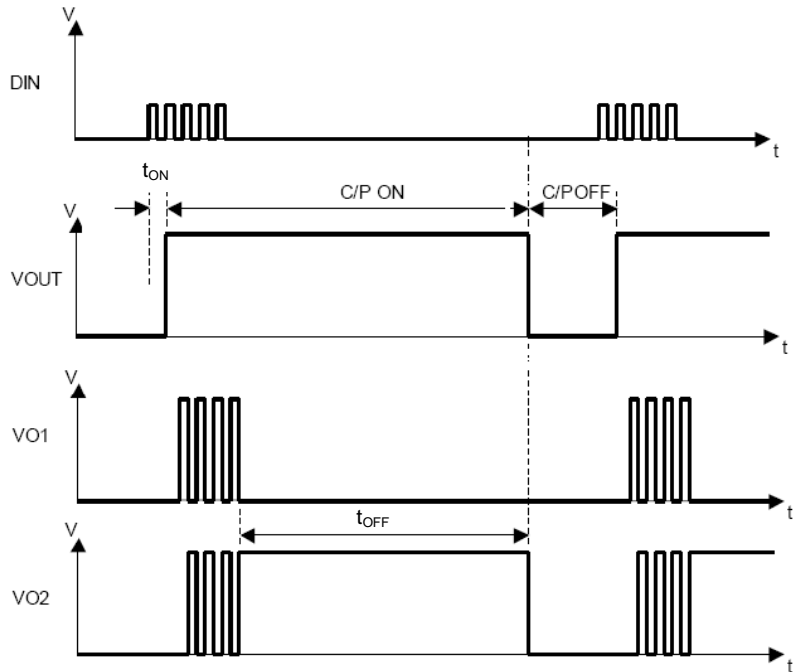

**Application Information** (continued)

**Output Configuration**

The PAM8904 is able to be configured either in a differential or a single ended configuration.

**Short-Circuit Protection**

The PAM8904 has short circuit protection circuitry on the outputs to prevent damage. Once a short circuit is detected on the outputs the chip will limit the total current to protect the output device. This is not a latched fault; once the short is removed the normal operation is restored.

**Thermal Protection**

If the junction temperature of the PAM8904 exceeds +150°C the device will enter overtemperature shutdown. The outputs and the charge pump will be switched off. Once the junction temperature cools down to its normal operating condition, the IC will re-start automatically.

**Ordering Information**

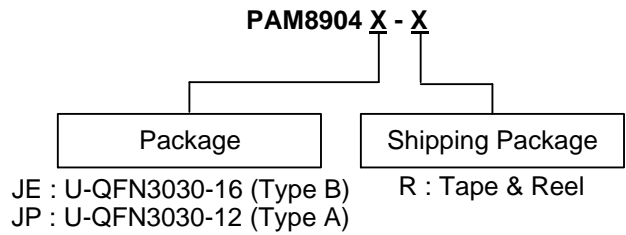

Part Number	Package Type	Shipping
PAM8904JER	U-QFN3030-16 (Type B)	3,000/Tape & Reel
PAM8904JPR	U-QFN3030-12 (Type A)	3,000/Tape & Reel

**Marking Information**

U-QFN3030-16 (Type B) / U-QFN3030-12 (Type A)

(Top View)

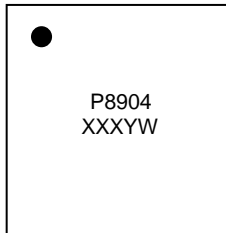

P8904: Product Code  
 XXX: Internal Code  
 Y: Year 0-9  
 W: Week: A-Z: 1~26 weeks;  
 a-z: 27~52 weeks;  
 z represents 52 and 53 weeks

**Package Outline Dimensions**

Please see <http://www.diodes.com/package-outlines.html> for the latest version.

**(1) Package Type: U-QFN3030-16 (Type B)**

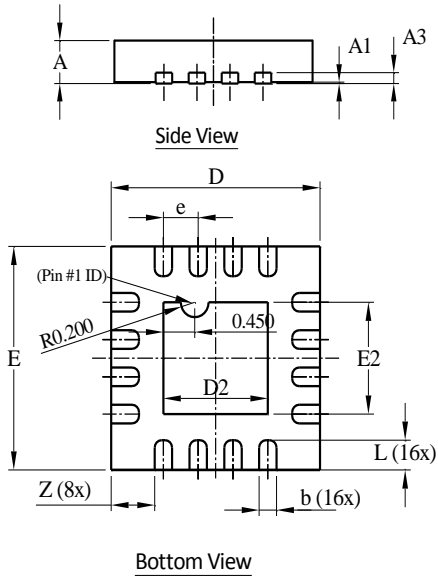

U-QFN3030-16 Type B			
Dim	Min	Max	Typ
A	0.55	0.65	0.60
A1	0	0.05	0.02
A3	-	-	0.15
b	0.18	0.28	0.23
D	2.95	3.05	3.00
D2	1.40	1.60	1.50
E	2.95	3.05	3.00
E2	1.40	1.60	1.50
e	-	-	0.50
L	0.35	0.45	0.40
Z	-	-	0.625
All Dimensions in mm			

**(2) Package Type: U-QFN3030-12 (Type A)**

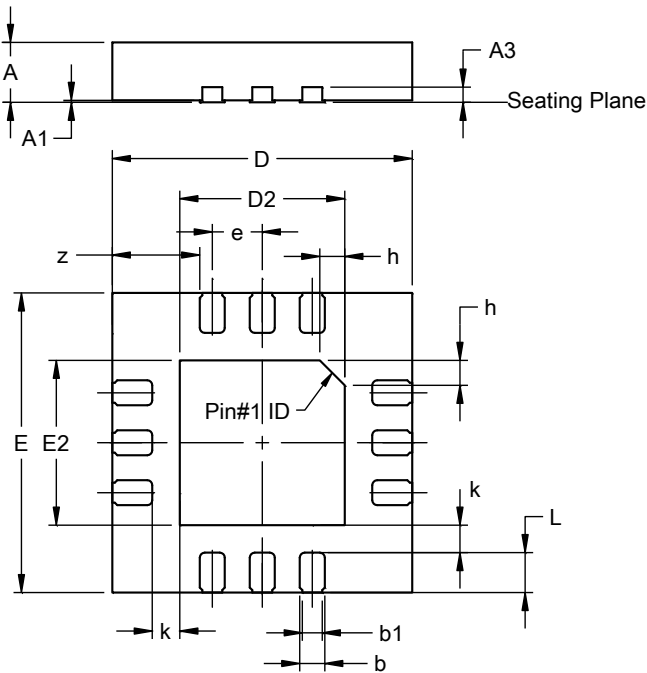

U-QFN3030-12 (Type A)			
Dim	Min	Max	Typ
A	0.55	0.65	0.60
A1	0.00	0.05	0.02
A3	--	--	0.152
b	0.20	0.35	0.25
b1	0.15	0.25	0.20
D	2.95	3.05	3.00
D2	1.55	1.75	1.65
E	2.95	3.05	3.00
E2	1.55	1.75	1.65
e	--	--	0.50
h	--	--	0.25
L	0.35	0.45	0.40
k	--	--	0.275
z	--	--	0.875
All Dimensions in mm			

**Suggested Pad Layout**

Please see <http://www.diodes.com/package-outlines.html> for the latest version.

**(1) Package Type: U-QFN3030-16 (Type B)**

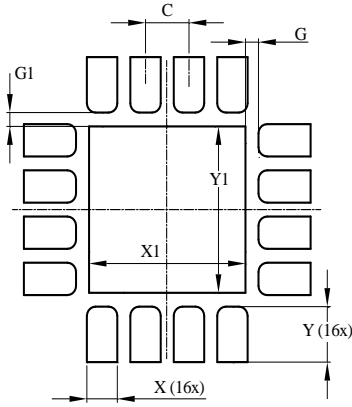

Dimensions	Value (in mm)
C	0.500
G	0.150
G1	0.150
X	0.350
X1	1.800
Y	0.600
Y1	1.800

**(2) Package Type: U-QFN3030-12 (Type A)**

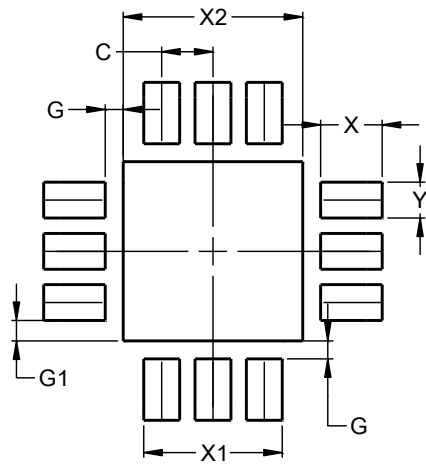

Dimensions	Value (in mm)
C	0.500
G	0.175
G1	0.200
X	0.600
X1	1.350
X2	1.750
Y	0.350
Y1	1.750



#### **IMPORTANT NOTICE**

DIODES INCORPORATED MAKES NO WARRANTY OF ANY KIND, EXPRESS OR IMPLIED, WITH REGARDS TO THIS DOCUMENT, INCLUDING, BUT NOT LIMITED TO, THE IMPLIED WARRANTIES OF MERCHANTABILITY AND FITNESS FOR A PARTICULAR PURPOSE (AND THEIR EQUIVALENTS UNDER THE LAWS OF ANY JURISDICTION).

Diodes Incorporated and its subsidiaries reserve the right to make modifications, enhancements, improvements, corrections or other changes without further notice to this document and any product described herein. Diodes Incorporated does not assume any liability arising out of the application or use of this document or any product described herein; neither does Diodes Incorporated convey any license under its patent or trademark rights, nor the rights of others. Any Customer or user of this document or products described herein in such applications shall assume all risks of such use and will agree to hold Diodes Incorporated and all the companies whose products are represented on Diodes Incorporated website, harmless against all damages.

Diodes Incorporated does not warrant or accept any liability whatsoever in respect of any products purchased through unauthorized sales channel. Should Customers purchase or use Diodes Incorporated products for any unintended or unauthorized application, Customers shall indemnify and hold Diodes Incorporated and its representatives harmless against all claims, damages, expenses, and attorney fees arising out of, directly or indirectly, any claim of personal injury or death associated with such unintended or unauthorized application.

Products described herein may be covered by one or more United States, international or foreign patents pending. Product names and markings noted herein may also be covered by one or more United States, international or foreign trademarks.

This document is written in English but may be translated into multiple languages for reference. Only the English version of this document is the final and determinative format released by Diodes Incorporated.

#### **LIFE SUPPORT**

Diodes Incorporated products are specifically not authorized for use as critical components in life support devices or systems without the express written approval of the Chief Executive Officer of Diodes Incorporated. As used herein:

A. Life support devices or systems are devices or systems which:

1. are intended to implant into the body, or
2. support or sustain life and whose failure to perform when properly used in accordance with instructions for use provided in the labeling can be reasonably expected to result in significant injury to the user.

B. A critical component is any component in a life support device or system whose failure to perform can be reasonably expected to cause the failure of the life support device or to affect its safety or effectiveness.

Customers represent that they have all necessary expertise in the safety and regulatory ramifications of their life support devices or systems, and acknowledge and agree that they are solely responsible for all legal, regulatory and safety-related requirements concerning their products and any use of Diodes Incorporated products in such safety-critical, life support devices or systems, notwithstanding any devices- or systems-related information or support that may be provided by Diodes Incorporated. Further, Customers must fully indemnify Diodes Incorporated and its representatives against any damages arising out of the use of Diodes Incorporated products in such safety-critical, life support devices or systems.

Copyright © 2020, Diodes Incorporated

[www.diodes.com](http://www.diodes.com)

## X-ON Electronics

Largest Supplier of Electrical and Electronic Components

*Click to view similar products for [Audio Amplifiers](#) category:*

*Click to view products by [Diodes Incorporated](#) manufacturer:*

Other Similar products are found below :

[LV47002P-E](#) [NCP2811AFCT1G](#) [NCP2890AFCT2G](#) [SSM2377ACBZ-R7](#) [IS31AP4915A-QFLS2-TR](#) [NCP2820FCT2G](#) [TDA1591T](#)  
[TDA7563AH](#) [SSM2529ACBZ-R7](#) [MAX9890AETA+T](#) [TS2012EIJT](#) [NCP2809BMUTXG](#) [NJW1157BFC2](#) [SSM2375CBZ-REEL7](#)  
[IS31AP4996-GRLS2-TR](#) [STPA002OD-4WX](#) [NCP2823BFCT1G](#) [MAX9717DETA+T](#) [MAX9717CETA+T](#) [MAX9724AEBC+TG45](#)  
[LA4450L-E](#) [IS31AP2036A-CLS2-TR](#) [TDA7563ASMTR](#) [AS3561-DWLT](#) [SSM2517CBZ-R7](#) [SABRE9601K](#) [THAT1646W16-U](#)  
[PAM8965ZLA40-13](#) [BD37532FV-E2](#) [BD5638NUX-TR](#) [BD37512FS-E2](#) [BD37543FS-E2](#) [BD3814FV-E2](#) [TPA3140D2PWPR](#) [TS2007EIJT](#)  
[IS31AP2005-DLS2-TR](#) [AS3410-EQFP-500](#) [FDA4100LV](#) [TS4994EIJT](#) [NCP2820FCT1G](#) [NCP2823AFCT2G](#) [NCS2211MNTXG](#)  
[CPA2233CQ16-A1](#) [OPA1612AQDRQ1](#) [TDA7492](#) [SSM2519ACBZ-R7](#) [ZXCD1210JB16TA](#) [TPA3255DDVR](#) [TAS5722LRSMT](#)  
[NCP2823AFCCT2G](#)