

6.5 Gbps SAS2, SATA3, XAUI 2 Differential Channel, 2:1 Mux/DeMux Switch

Features

- SAS2, SATA3, XAUI switch
- 2 Differential Channel, 2:1 Mux/DeMux
- 6.5 Gbps performance
- Bi-directional operation
- Low Bit-to-Bit Skew, 6ps max
- Low Insertion Loss: -2.3dB@3GHz(6Gbps)
- Low Crosstalk: -43dB@3GHz (6.0Gbps)
- Low Off Isolation: -21dB@3GHz (6.0Gbps)
- V_{DD} Operating Range: 1.5V to 1.8V, ±0.1V
- ESD Tolerance 2KV HBM I/O
- Packaging: – 28 contact TQFN (ZH, 3.5 × 5.5mm)

Description

Pericom Semiconductor’s PI2DBS6212 is a 4 to 2 bi-directional differential channel multiplexer/demultiplexer switch supporting 6.5 Gbps applications. Due to its low bit-to-bit skew, high channel-to-channel noise isolation and high bandwidth, this product is ideal for switching two sources to a single receiver, or alternatively, one source to two receivers.

Application

- SAS2, SATA3, XAUI, Infiniband, Hype Transport, Rapid I/O
- Computers, servers, storage, instrumentation, telecom, networking.

Block Diagram

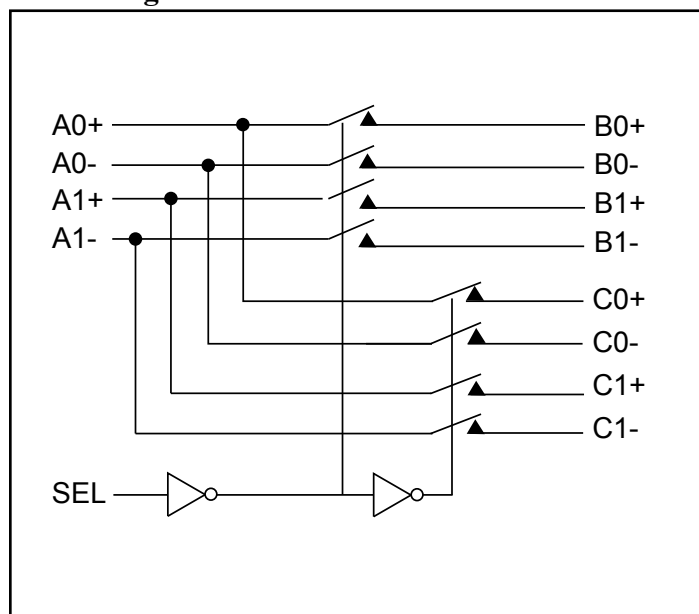

Pin Description

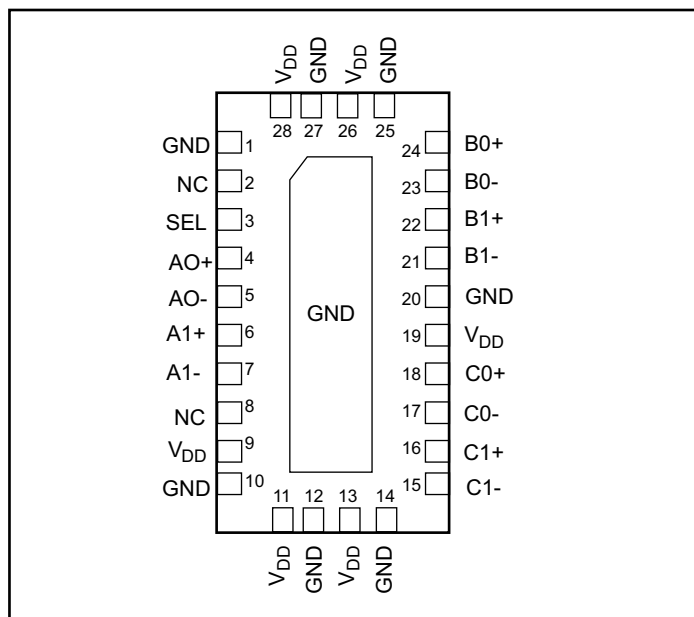

Truth Table

Function	SEL
A to B	L
A to C	H

Maximum Ratings

(Above which useful life may be impaired. For user guidelines, not tested.)

Storage Temperature	-65°C to +150°C
Supply Voltage to Ground Potential	-0.5V to +2.5V
DC Input Voltage	-0.5V to +V _{DD}
DC Output Current	120mA
Power Dissipation	0.5W

Note: Stresses greater than those listed under MAXIMUM RATINGS may cause permanent damage to the device. This is a stress rating only and functional operation of the device at these or any other conditions above those indicated in the operational sections of this specification is not implied. Exposure to absolute maximum rating conditions for extended periods may affect reliability.

Power Supply Characteristics

Parameters	Description	Test Conditions ⁽¹⁾	Min.	Typ. ⁽²⁾	Max.	Units
I _{CC}	Quiescent Power Supply Current	V _{DD} = Max., V _{IN} = GND or V _{DD}		200	400	μA

Notes:

- For Max. or Min. conditions, use appropriate value specified under Electrical Characteristics for the applicable device type.
- Typical values are at V_{DD} = 1.8V, T_A = 25°C ambient and maximum loading.

DC Electrical Characteristics for Switching over Operating Range (T_A = -40°C to +85°C, V_{DD} = 1.5V to 1.8V)

Parameter	Description	Test Conditions	Min.	Typ.	Max.	Units
V _{IH}	Input HIGH Voltage, SEL input	Guaranteed HIGH level	0.65 x V _{DD}	-	-	V
V _{IL}	Input LOW Voltage, SEL input	Guaranteed LOW level	-0.5	-	0.35 x V _{DD}	
V _{IK}	Clamp Diode Voltage, SEL input	V _{DD} = Max., I _{IN} = -18mA	-	-0.7	-1.2	
I _{IH}	Input HIGH Current for SEL	V _{DD} = Max., V _{IN} = V _{DD}	-10	-	+10	μA
I _{OZ}	Channel Leakage Current	V _{DD} = Max., V _{IN} = 1.8V	-10	-	+10	
I _{IL}	Input LOW Current	V _{DD} = Max., V _{IN} = GND	-20	-	+10	
V _{I DC}	DC Signal Voltage Range	V _O /V _I > 95%, R _L = 10K	-0.5		2.5	V
		V _O /V _I > 80%, R _L = 50-Ohms	-0.4		1.2	

Switching Characteristics (T_A = -40° to +85°C, V_{DD} = 1.5V to 1.8V)

Parameter	Description	Min.	Typ.	Max.	Units
t _{PZH} , t _{PZL}	Line Enable Time - SEL to A _N , B _N , C _N	0.5	-	9.0	ns
t _{PHZ} , t _{PLZ}	Line Disable Time - SEL to A _N , B _N , C _N	0.5	-	9.0	
t _{b-b}	Bit-to-bit skew within the same differential pair			10	ps
t _{ch-ch}	Channel-to-channel skew			15	
t _{diff}	Differential delay - A _N to B _N or C _N			20	

Notes:

- For max. or min. conditions, use appropriate value specified under Electrical Characteristics for the applicable device type.

Dynamic Electrical Characteristics Over the Operating Range ($T_A = -40^\circ$ to $+85^\circ\text{C}$, $V_{DD} = 1.5\text{V}$ to 1.8V)

Parameter	Description	Test Conditions	Min.	Typ.	Max.	Units
BW	Bandwidth -3dB			4.1		
V_{IF}	Max Signal Frequency Range	Insertion loss 1.5dB, $V_{IN}=0.8\text{Vpp}$, DC=0V	2.5			GHz
		Insertion loss 1.5dB, $V_{IN}=0.6\text{Vpp}$, DC=0.9V	2.5			
		Insertion loss 3dB, $V_{IN}=0.8\text{Vpp}$, DC=0V	4.0			
		Insertion loss 3dB, $V_{IN}=0.6\text{Vpp}$, DC=0.9V	4.0			
P-1dB	1 dB Compression Input Signal	$R_L = 50$, $f=375\text{MHz}$, sin wave, DC=0V	1.2			Vpp
		$R_L = 50$, $f=375\text{MHz}$, sin wave, DC=0.45V	2.0			
		$R_L = 50$, $f=375\text{MHz}$, sin wave, DC=0.9V	2.4			
R_{LOSS}	Return Loss	$f = 3 \text{ GHz}$		-18		dB
X_{TALK}	Crosstalk	$f = 3.0 \text{ GHz}$		-43		
O_{IRR}	OFF Isolation	$f = 3.0 \text{ GHz}$		-21		
I_{LOSS}	Differential Insertion Loss	$f = 3 \text{ GHz}$		-2.3		

Notes:

1. Guaranteed by design.

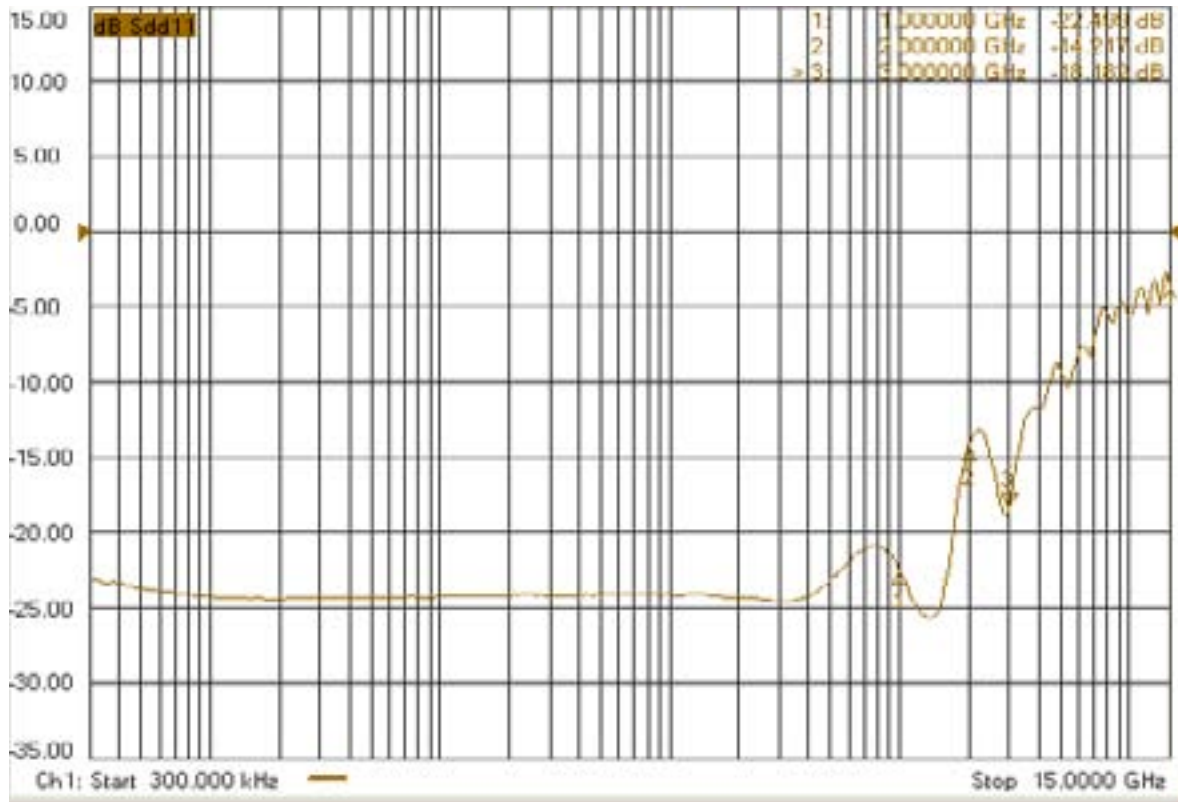

Return Loss

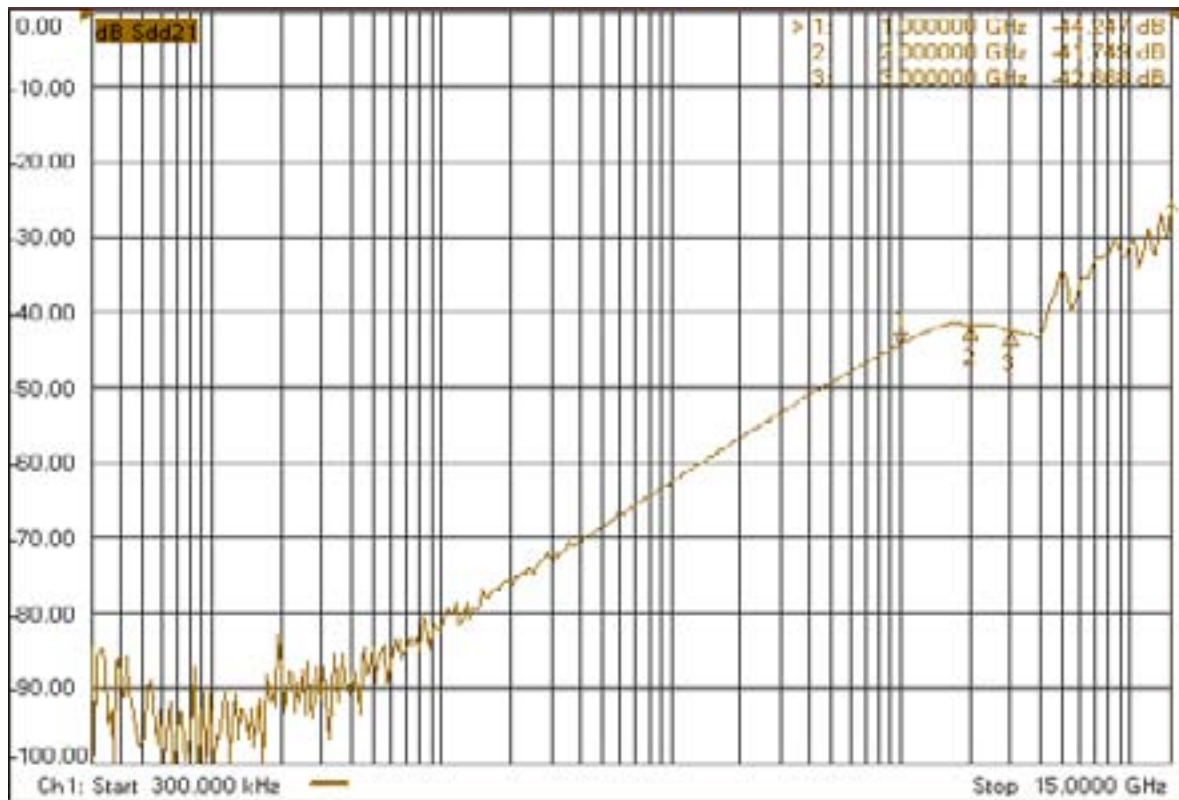

Crosstalk

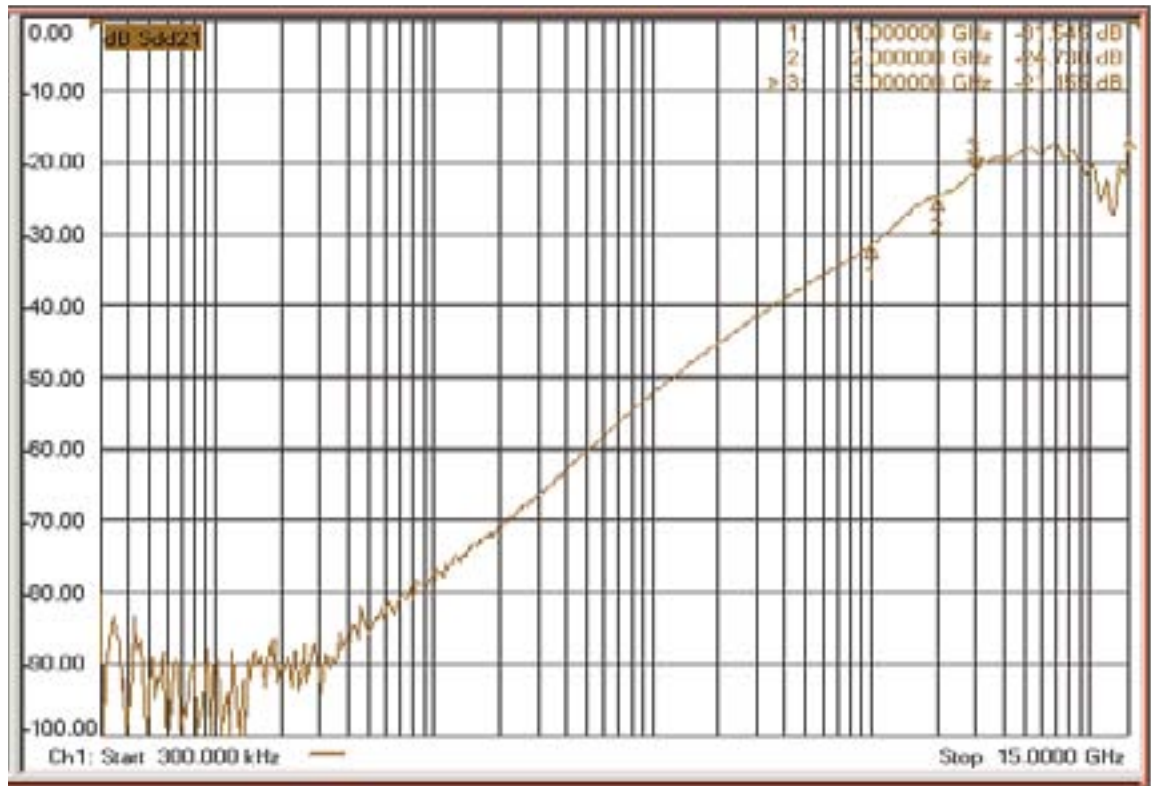
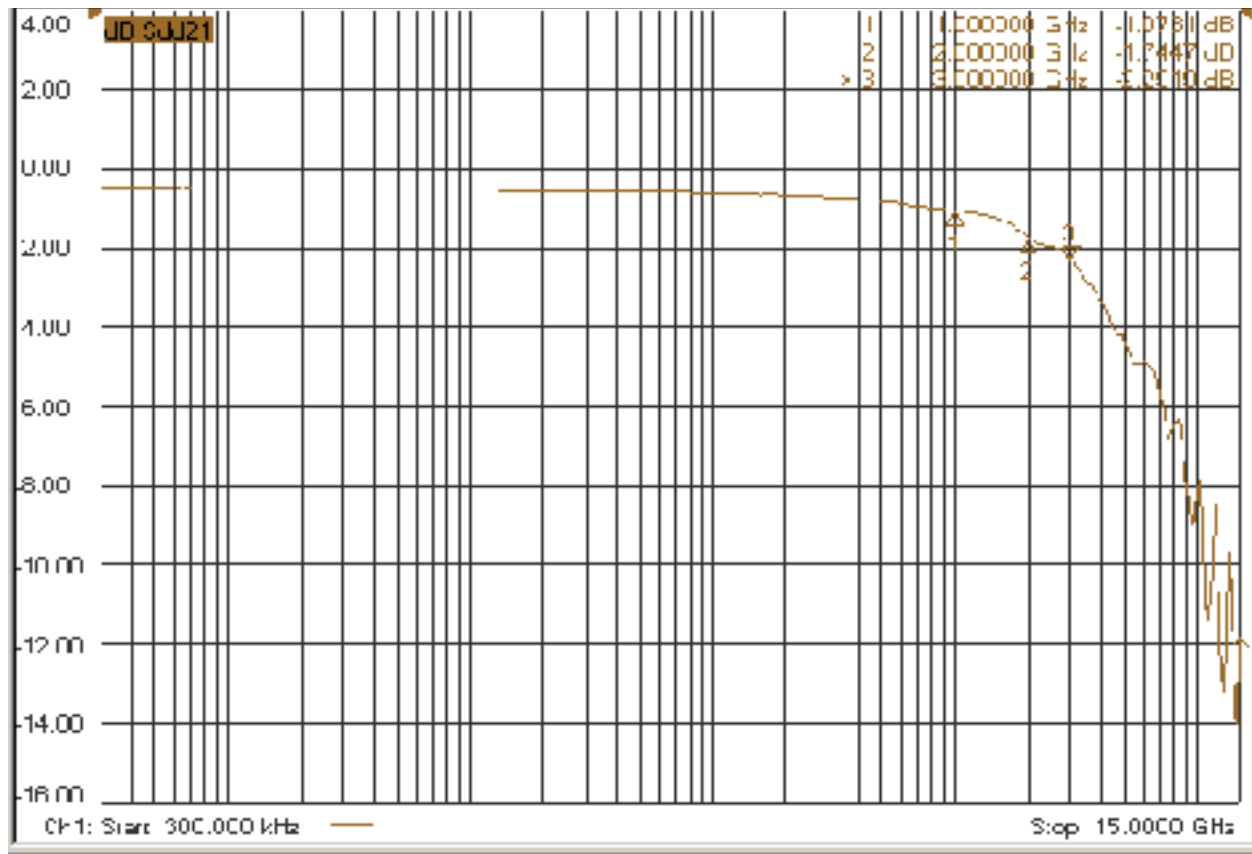

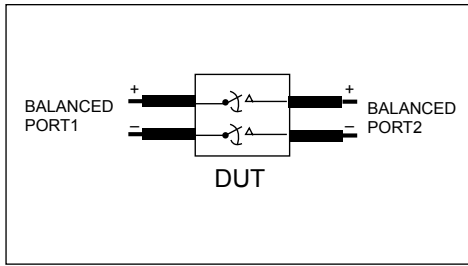
Off Isolation

Insertion Loss

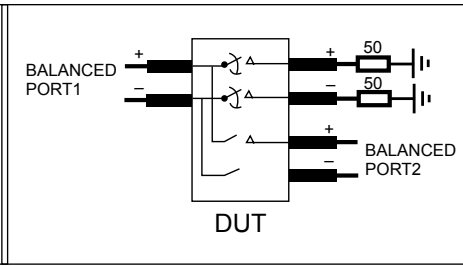

Diff. Insertion Loss and Return Test Circuit

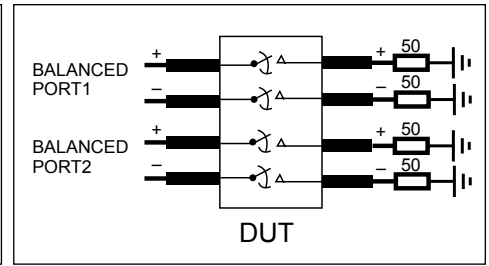

Diff. Off Isolation Test Circuit



Diff. Near End Xtalk Test Circuit

Test Circuit for Electrical Characteristics⁽¹⁻⁵⁾

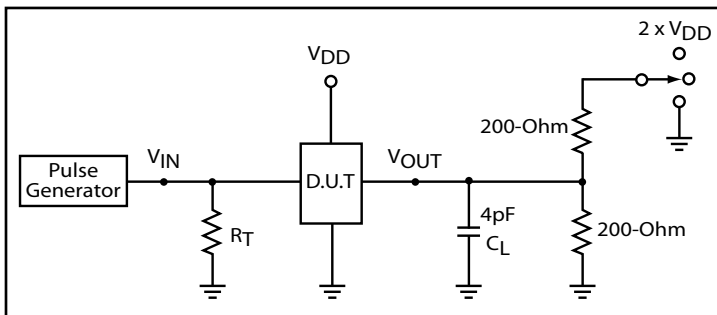

Notes:

1. C_L = Load capacitance: includes jig and probe capacitance.
2. R_T = Termination resistance: should be equal to Z_{OUT} of the Pulse Generator
3. Output 1 is for an output with internal conditions such that the output is low except when disabled by the output control.
output 2 is for an output with internal conditions such that the output is high except when disabled by the output control.
4. All input impulses are supplied by generators having the following characteristics: $PRR \leq \text{MHz}$, $Z_O = 50\Omega$, $t_r \leq 2.5\text{ns}$, $t_f \leq 2.5\text{ns}$.
5. The outputs are measured one at a time with one transition per measurement.

Switch Positions

Test	Switch
t_{PLZ} , t_{PZL}	$2 \times V_{DD}$
t_{PHZ} , t_{PZH}	GND
Prop Delay	Open

Switching Waveforms

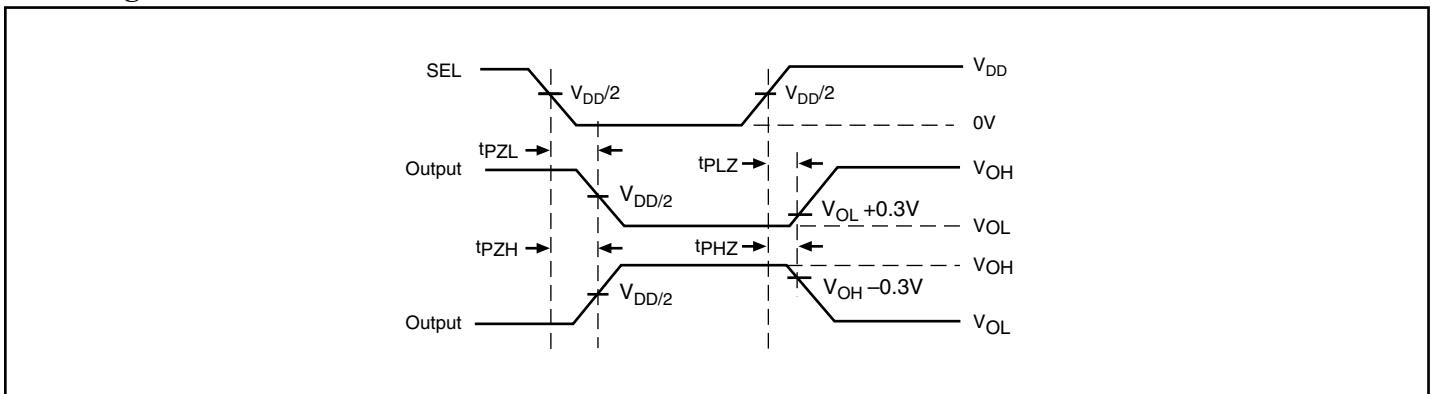

Voltage Waveforms Enable and Disable Times

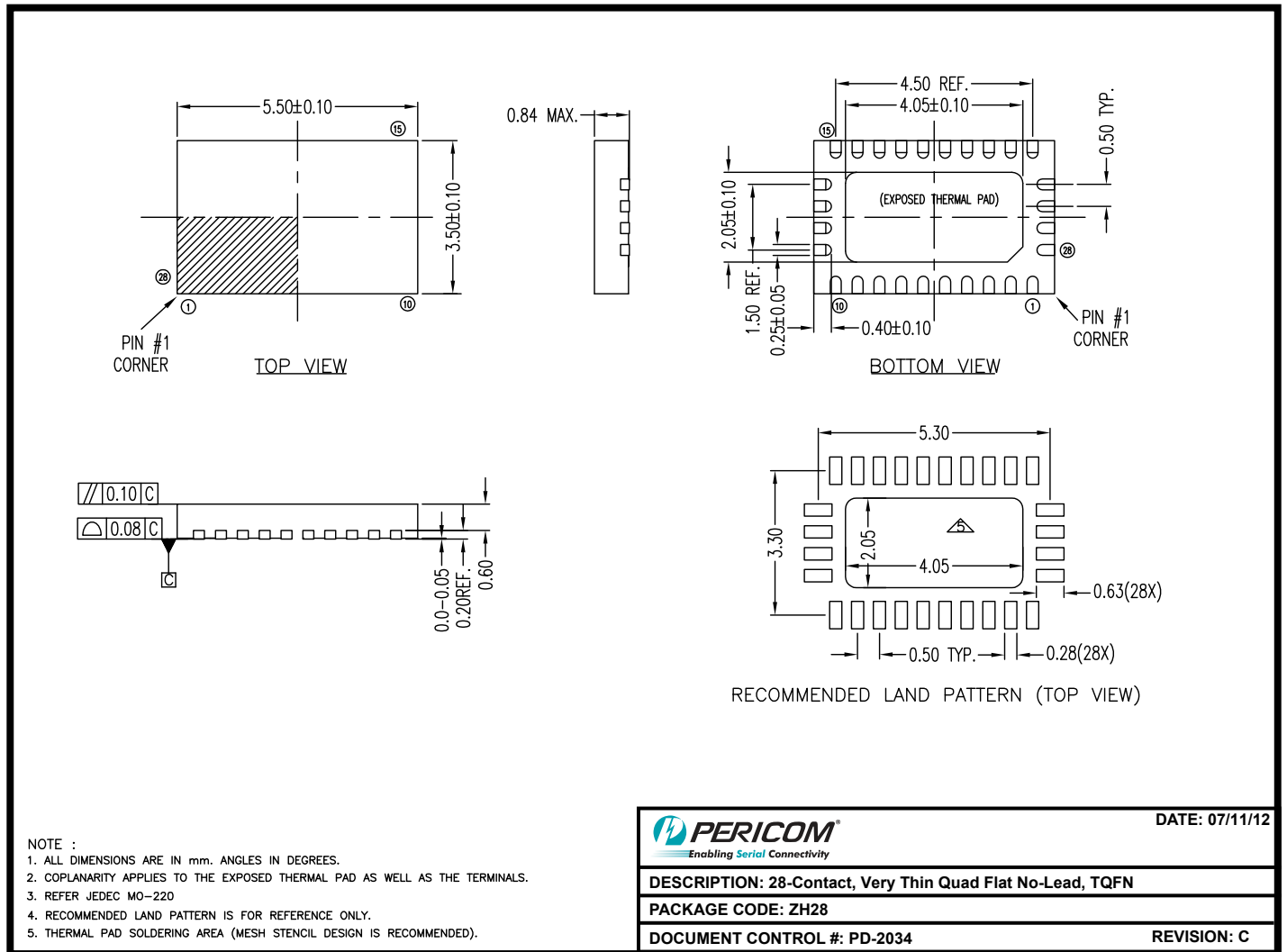

12-0419

Note:

- For latest package info, please check: <http://www.pericom.com/products/packaging/mechanicals.php>

Ordering Information

Ordering Code	Package Code	Package Type
PI2DBS6212ZHE	ZH	Pb-free & Green, 28-Contact TQFN

Notes:

- Thermal characteristics can be found on the company web site at www.pericom.com/packaging/
- E = Pb-free and Green
- Adding an X suffix = Tape/Reel

X-ON Electronics

Largest Supplier of Electrical and Electronic Components

Click to view similar products for [Multiplexer Switch ICs](#) category:

Click to view products by [Diodes Incorporated](#) manufacturer:

Other Similar products are found below :

[NLV74HC4066ADR2G](#) [HEF4051BP](#) [MC74HC4067ADTG](#) [DG508AAK/883B](#) [NLV14051BDG](#) [016400E](#) [PI3V512QE](#) [7705201EC](#)
[PI2SSD3212NCE](#) [PI3L100QE](#) [NLAS3257CMX2TCG](#) [PI5A3157BC6EX](#) [PI3V512QEX](#) [PI3DBS16213ZLEX](#) [PI3DBS16415ZHEX](#)
[PS509LEX](#) [MUX36S16IRSNR](#) [74LVC1G3157GM-Q10X](#) [TC7W53FK,LF](#) [CD4053BM96](#) [MC74HC4053ADWR2G](#) [MAX4051AEEE+](#)
[PI3L720ZHEX](#) [ADG1404YRUZ-REEL7](#) [ADG1208YRZ-REEL7](#) [CD4053BPWRG4](#) [ADG658TRUZ-EP](#) [FSA1256L8X_F113](#) [PI5V330QE](#)
[PI5V331QE](#) [5962-8771601EA](#) [ADG5249FBRUZ](#) [ADG1438BRUZ](#) [ADG5207BCPZ-RL7](#) [ADW54003-0](#) [AD7506JNZ](#) [AD7506KNZ](#)
[AD7506SQ](#) [AD8170AR](#) [AD8183ARUZ](#) [AD8184ANZ](#) [AD8185ARUZ](#) [AD8187ARUZ](#) [AD8188ARUZ](#) [AD8189ARUZ](#) [ADG1208YRUZ-](#)
[REEL7](#) [ADG1409YCPZ-REEL7](#) [ADG5209FBRUZ](#) [ADG1408YRUZ-REEL7](#) [ADG659YRUZ-REEL7](#)