

## 3.2Gbps 2 Differential Channel Serial Re-driver with Equalization, Squelch and Flow-Through Pinout

### Features

- SATA s/m output drive
- Two 3.2Gbps differential channels
- Adjustable Receiver Equalization
- 100-Ohm Differential CML I/O's
- Input signal level detect and squelch for each channel
- Low Power (100mW per Channel)
- Stand-by Mode – Power Down State
- V<sub>CC</sub> Operating Range: 1.5V to 1.8V
- Packaging (Pb-free & Green):  
— 20-lead SSOP

### Description

Pericom Semiconductor's PI2EQX3211B is a low power, signal re-driver. The device provides programmable equalization, by using 2 select bits, EQA and EQB, to optimize performance over a variety of physical mediums by reducing Inter-Symbol Interference. PI2EQX3211B supports two 100-Ohm Differential CML data I/O's between the Protocol ASIC to a switch fabric, across a backplane, or to extend the signals across other distant data pathways on the user's platform.

The integrated equalization circuitry provides flexibility with signal integrity of the signal before the re-driver. Whereas the integrated de-emphasis circuitry provides flexibility with signal integrity of the signal after the re-driver.

A low-level input signal detection and output squelch function is provided for each channel. Each channel operates fully independently. When the channels are enabled (EN=1) and operating, that channels input signal level (on xI+/-) determines whether the output is enabled. If the input level of the channel falls below the active threshold level (V<sub>th</sub>-) then the outputs are driven to the common mode voltage.

In addition to providing signal re-conditioning, Pericom's PI2EQX3211B also provides power management Stand-by mode operated by the Enable pin.

### Block Diagram

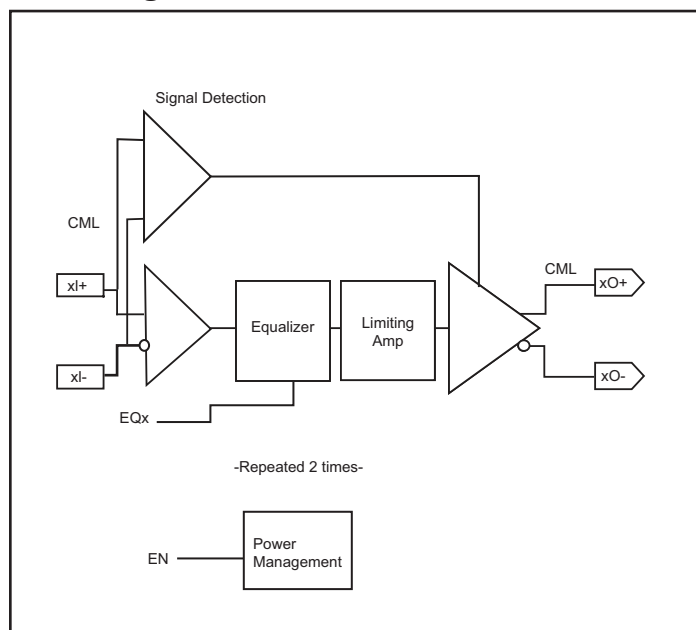

### Pin Description

EQA	1	20	EN
VDD	2	19	VDD
AI+	3	18	AO+
AI-	4	17	AO-
GND	5	16	GND
VDD	6	15	VDD
BO+	7	14	BI+
BO-	8	13	BI-
GND	9	12	GND
EQB	10	11	VDD

**Pin Description**

Pin #	Pin Name	I/O	Description
3	AI+	I	Positive CML Input Channel A with internal 50Ω pull down
4	AI-	I	Negative CML Input Channel A with internal 50Ω pull down
18	AO+	O	Positive CML Output Channel A with internal 50Ω pull up to VDD during normal operation and 2kΩ when EN=0. Drives to output common mode voltage when input is <math>V_{TH-}</math>.
17	AO-	O	Negative CML Output Channel A with internal 50Ω pull up to VDD during normal operation and 2kΩ when EN=0. Drives to output common mode voltage when input is <math>V_{TH-}</math>.
14	BI+	I	Positive CML Input Channel B with internal 50Ω pull down
13	BI-	I	Negative CML Input Channel B with internal 50Ω pull down
7	BO+	O	Positive CML Output Channel B with internal 50Ω pull up to VDD during normal operation and 2kΩ when EN=0. Drives to output common mode voltage when input is <math>V_{TH-}</math>.
8	BO-	O	Negative CML Output Channel B with internal 50Ω pull up to VDD during normal operation and 2kΩ when EN=0. Drives to output common mode voltage when input is <math>V_{TH-}</math>.
20	EN	I	EN is the enable pin. A LVCMOS high provides normal operation. A LVCMOS low selects a low power down mode.
5, 9, 12, 16	GND	PWR	Supply Ground
1	EQA	I	Selection pins for equalizer (see Equalizer Selection Table) w/ 50KΩ internal pull up
10	EQB	I	
2, 6, 11, 15, 19	V <sub>DD</sub>	PWR	Supply Voltage, 1.5V to 1.8V (±0.1V)

**Equalizer Selection**

EQx	Compliance Channel
0	[0:2.5dB] @ 1.6 GHz
1	[4.5:6.5dB] @ 1.6 GHz

### Maximum Ratings

(Above which useful life may be impaired. For user guidelines, not tested.)

Storage Temperature.....	-65°C to +150°C
Supply Voltage to Ground Potential.....	-0.5V to +2.5V
DC SIG Voltage.....	-0.5V to V <sub>CC</sub> +0.5V
Current Output .....	-25mA to +25mA
Power Dissipation Continuous.....	500mW
Operating Temperature.....	0 to +70°C

**Note:**

Stresses greater than those listed under MAXIMUM RATINGS may cause permanent damage to the device. This is a stress rating only and functional operation of the device at these or any other conditions above those indicated in the operational sections of this specification is not implied. Exposure to absolute maximum rating conditions for extended periods may affect reliability.

### AC/DC Electrical Characteristics

Symbol	Parameter	Conditions	Min.	Typ.	Max.	Units
P <sub>s</sub>	Supply Power	EN = LVCMOS Low			0.1	W
		EN = LVCMOS High			0.3	
	Latency	From input to output		2.0		ns
<b>CML Receiver Input</b>						
V <sub>RX-DIFFP-P</sub>	Differential Input Peak-to-peak Voltage		0.200			V
V <sub>RX-CM-ACP</sub>	AC Peak Common Mode Input Voltage				150	mV
V <sub>TH-SD</sub>	Signal Detect Threshold	EN = High	50		200	
Z <sub>RX-DIFF-DC</sub>	DC Differential Input Impedance		80	100	120	Ω
Z <sub>RX-DC</sub>	DC Input Impedance		40	50	60	
<b>Equalization</b>						
J <sub>RS</sub>	Residual Jitter <sup>(1,2)</sup>	Total Jitter			0.3	Ulp-p
		Deterministic jitter			0.2	
J <sub>RM</sub>	Random Jitter <sup>(1,2)</sup>			1.5		psrms

**Notes**

- K28.7 pattern is applied differentially at point A as shown in Figure 1.
- Total jitter does not include the signal source jitter. Total jitter (TJ) = (14.1 × RJ + DJ) where RJ is random RMS jitter and DJ is maximum deterministic jitter. Signal source is a K28.5 ± pattern (00 1111 1010 11 0000 0101) for the deterministic jitter test and K28.7 (0011111000) or equivalent for random jitter test. Residual jitter is that which remains after equalizing media-induced losses of the environment of Figure 1 or its equivalent. The deterministic jitter at point B must be from media-induced loss, and not from clock source modulation. Jitter is measured at 0V at point C of Figure 1.

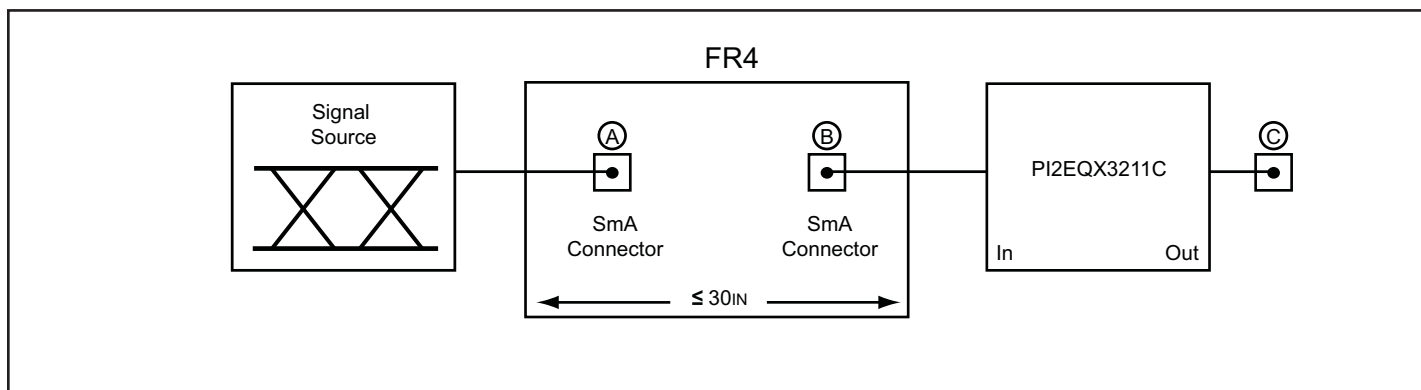

**Figure 1. Test Condition Referenced in the Electrical Characteristic Table**

### AC/DC Electrical Characteristics

Symbol	Parameter	Conditions	Min.	Typ.	Max.	Units
<b>CML Transmitter Output (100Ω differential)</b>						
$V_{\text{DIFFP}}$	Output Voltage Swing	Differential Swing $ V_{\text{TX-D+}} - V_{\text{TX-D-}} $	200		375	mVp-p
$V_{\text{TX-DIFFP-P}}$	Differential Peak-to-peak Output Voltage	$V_{\text{TX-DIFFP-P}} = 2 *  V_{\text{TX-D+}} - V_{\text{TX-D-}} $	400		750	mV
$V_{\text{TX-C}}^{(2)}$	Common-Mode Voltage	$ V_{\text{TX-D+}} + V_{\text{TX-D-}}  / 2$		$V_{\text{DD}} - 0.3$		V
$t_{\text{F}}, t_{\text{R}}$	Transition Time	20% to 80% <sup>(1)</sup>			150	ps
$Z_{\text{OUT}}$	Output resistance	Single ended	40	50	60	Ω
$Z_{\text{TX-DIFF-DC}}$	DC Differential TX Impedance		80	100	120	Ω
$C_{\text{TX}}$	AC Coupling Capacitor		0.3	4.7	12	nF
<b>LVC MOS Control Pins</b>						
$V_{\text{IH}}$	Input High Voltage		$0.65 \times V_{\text{DD}}$			V
$V_{\text{IL}}$	Input Low Voltage				$0.35 \times V_{\text{DD}}$	
$I_{\text{IH}}$	Input High Current				250	μA
$I_{\text{IL}}$	Input Low Current				500	

**Note:**

1. Using K28.7 (0011111000) pattern).
2. The parameter is determined by device characterization, and is not production tested

**Packaging Mechanical: 20-lead SSOP (H20)**

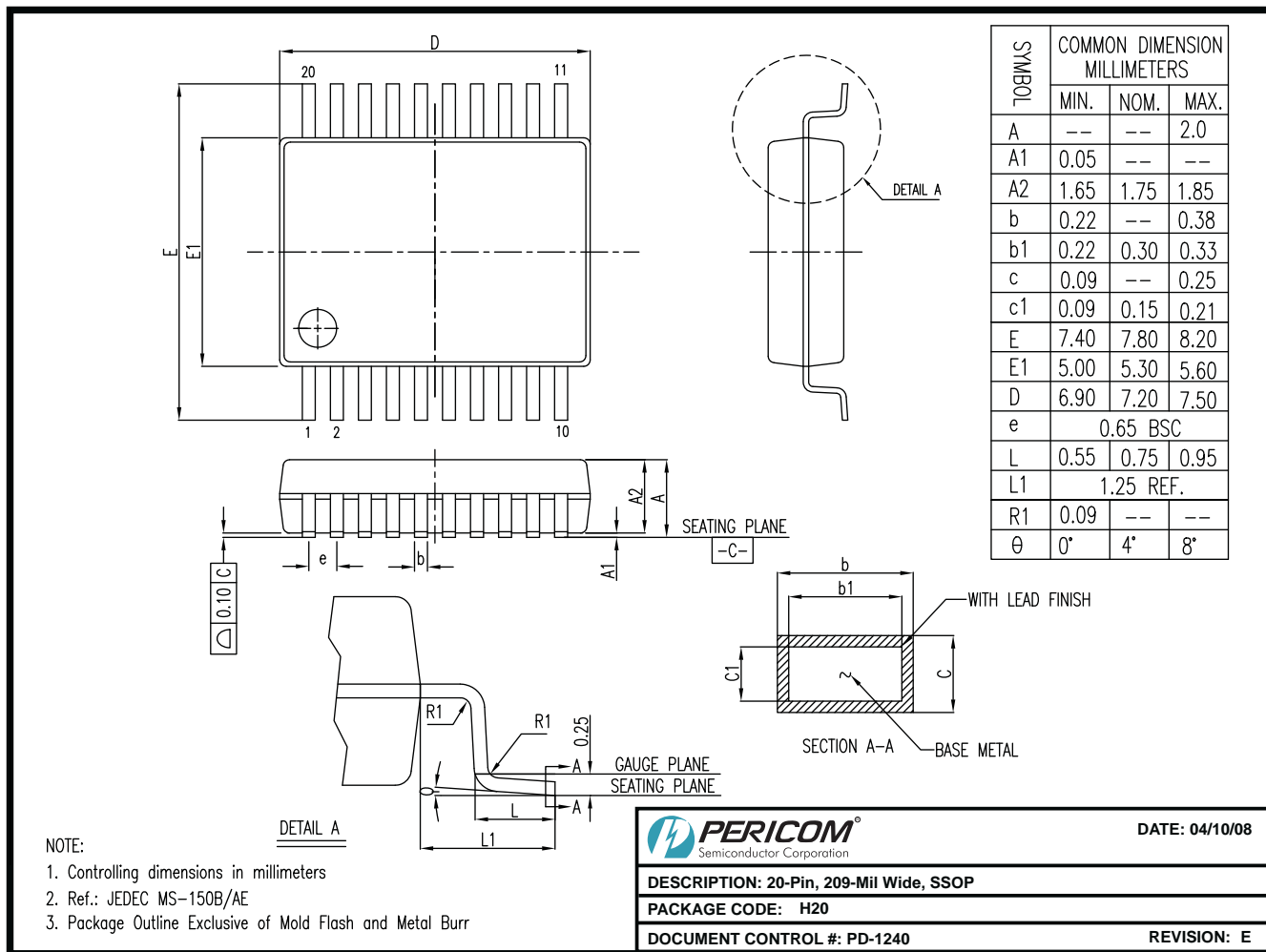

**Ordering Information**

Ordering Number	Package Code	Package Description
PI2EQX3211BHE	H	Pb-Free and Green 20-lead SSOP

**Notes:**

- Thermal characteristics can be found on the company web site at [www.pericom.com/packaging/](http://www.pericom.com/packaging/)
- E = Pb-free and Green
- X suffix = Tape/Reel

## X-ON Electronics

Largest Supplier of Electrical and Electronic Components

*Click to view similar products for [Buffers & Line Drivers](#) category:*

*Click to view products by [Diodes Incorporated](#) manufacturer:*

Other Similar products are found below :

[74AUP2G34FW3-7](#) [HEF4043BP](#) [NL17SG125DFT2G](#) [PI74FCT3244L](#) [MC74HCT365ADTR2G](#) [Le87401NQC](#) [Le87402MQC](#) [028192B](#)  
[042140C](#) [051117G](#) [070519XB](#) [NL17SZ07P5T5G](#) [NLU1GT126AMUTCG](#) [74AUP1G17FW5-7](#) [74LVC2G17FW4-7](#) [CD4502BE](#) [5962-](#)  
[8982101PA](#) [5962-9052201PA](#) [74LVC1G125FW4-7](#) [NL17SH17P5T5G](#) [NLV37WZ17USG](#) [NL17SH125P5T5G](#) [NLV37WZ07USG](#)  
[RHRXH162244K1](#) [74AUP1G34FW5-7](#) [74AUP1G07FW5-7](#) [74LVC1G126FW4-7](#) [74LVC2G126RA3-7](#) [NLX2G17CMUTCG](#)  
[74LVCE1G125FZ4-7](#) [Le87501NQC](#) [74AUP1G126FW5-7](#) [TC74HC4050AP\(F\)](#) [74LVCE1G07FZ4-7](#) [NLX3G16DMUTCG](#)  
[NLX2G06AMUTCG](#) [NLVVHC1G50DFT2G](#) [LE87100NQC](#) [LE87100NQCT](#) [LE87290YQC](#) [LE87290YQCT](#) [LE87511NQC](#) [LE87511NQCT](#)  
[LE87557NQC](#) [LE87557NQCT](#) [LE87614MQC](#) [LE87614MQCT](#) [74AUP1G125FW5-7](#) [NLU2G16CMUTCG](#) [MC74LCX244MN2TWG](#)