

PCI Express® 2.0, 1-Lane, 2:1 Mux/DeMux Switch w/ Single Enable

Features

- 2 Differential Channel, 2:1 Mux/DeMux
- PCI Express® 2.0 performance, 5.0 Gbps
- Bi-directional operation
- Low Bit-to-Bit Skew, 7ps
- Low Crosstalk: -38dB@2.5GHz
- Low Off Isolation: -25dB@2.5GHz
- V_{DD} Operating Range: 1.5V to 1.8V ±0.1V
- ESD Tolerance: 2kV
- Packaging: – 28-contact TQFN (3.5 × 5.5mm)

Description

Pericom Semiconductor’s PI2PCIE2212 is a 4 to 2 differential, bi-directional channel multiplexer/demultiplexer switch. Due to its low bit-to-bit skew, high channel-to-channel noise isolation and bandwidth, this product is ideal for PCI Express® 2.0 signal switching at 5.0Gbps.

Application

Switch a PCI Express® lane output between two PCI Express lane inputs

Block Diagram

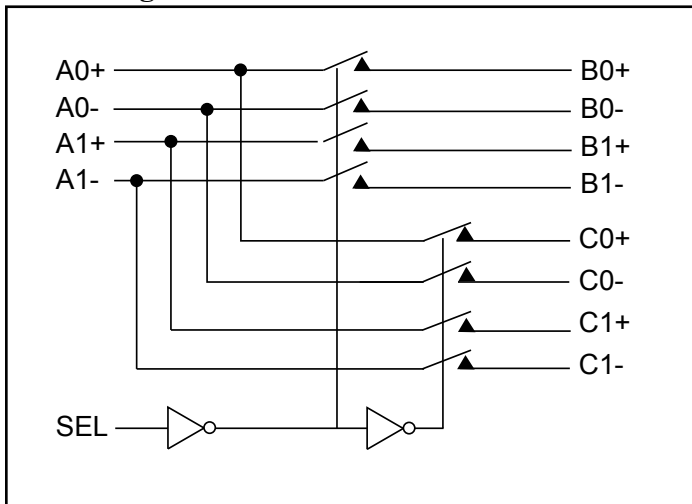

Truth Table

Function	SEL
A to B	L
A to C	H

Pin Description (Top-Side View)

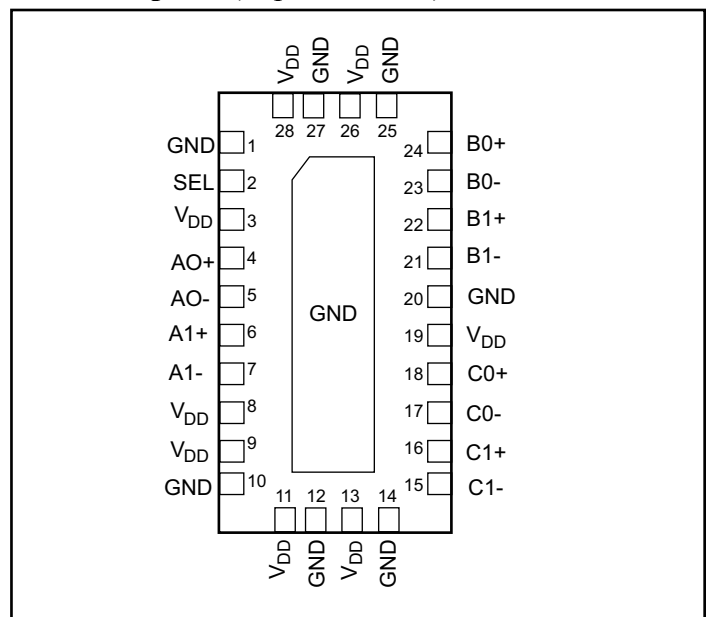

Maximum Ratings

(Above which useful life may be impaired. For user guidelines, not tested.)

Storage Temperature	-65°C to +150°C
Supply Voltage to Ground Potential	-0.5V to +2.5V
DC Input Voltage	-0.5V to +V _{DD}
DC Output Current	120mA
Power Dissipation	0.5W

Note: Stresses greater than those listed under MAXIMUM RATINGS may cause permanent damage to the device. This is a stress rating only and functional operation of the device at these or any other conditions above those indicated in the operational sections of this specification is not implied. Exposure to absolute maximum rating conditions for extended periods may affect reliability.

Power Supply Characteristics

Parameters	Description	Test Conditions	Min.	Typ. ⁽¹⁾	Max.	Units
I _{CC}	Quiescent Power Supply Current	V _{DD} = Max., V _{IN} = GND or V _{DD}		200	400	μA

Notes:

1. Typical values are at V_{DD} = 1.8V, T_A = 25°C ambient and maximum loading.

DC Electrical Characteristics (T_A = -40°C to +85°C, V_{DD} = 1.5V to 1.8V)

Parameter	Description	Test Conditions	Min.	Typ. ⁽¹⁾	Max.	Units
V _{IH}	Input HIGH Voltage Control Input, SEL	Guaranteed HIGH level	0.65 x V _{DD}	-	-	V
V _{IL}	Input LOW Voltage Control Input, SEL	Guaranteed LOW level	-0.5	-	0.35 x V _{DD}	
V _{IK}	Clamp Diode Voltage Control Input, SEL	V _{DD} = Max., I _{IN} = -18mA	-	-0.7	-1.2	
I _{IH}	Input HIGH Current Control Input, SEL	V _{DD} = Max., V _{IN} = V _{DD}	-	-	±5	μA
I _{IL}	Input LOW Current Control Input, SEL	V _{DD} = Max., V _{IN} = GND	-	-	±5	
V _{IDC}	DC Signal Voltage Range, Channel I/O (Ax, Bx, Cx)	V _O /V _I > 95%, R _L = 10K	-0.4		2.4	V
		V _O /V _I > 80%, R _L = 50-ohms	-0.3		2.0	

Notes:

1. Typical values are at V_{DD} = 1.8V, T_A = 25°C ambient and maximum loading.

Dynamic Electrical Characteristics⁽²⁾ (T_A = -40° to +85°C, V_{DD} = 1.5V to 1.8V)

Parameter	Description	Test Conditions	Min.	Typ. ⁽¹⁾	Max.	Units
X _{TALK}	Crosstalk	f = 2.5 GHz		-38		dB
O _{IRR}	OFF Isolation	f = 2.5 GHz		-25		
I _{LOSS}	Differential Insertion Loss	f = 2.5 GHz		-2.0		
BW	Bandwidth -3dB			3.8		GHz
V _{If}	Max Signal Frequency Range	Insertion loss 1.5 dB, V _{IN} = 0.6Vpp, DC = 0V	2.5			
		Insertion loss 1.5 dB, V _{IN} = 0.6Vpp, DC = 0.9V	2.5			
		Insertion loss 3.0 dB, V _{IN} = 0.6Vpp, DC = 0V	4.0			
		Insertion loss 3.0 dB, V _{IN} = 0.6Vpp, DC = 0.9V	4.0			
P-1dB	1 dB Compression Input Signal	RL = 50, f = 625MHz, Sinewave, DC = 0V	1.2			Vpp
		RL = 50, f = 625MHz, Sinewave, DC = 0.45V	2.0			
		RL = 50, f = 625MHz, Sinewave, DC = 0.9V	2.4			

Notes:

1. Typical values are at V_{DD} = 1.8V, T_A = 25°C ambient and maximum loading.
2. Guaranteed by design.

Switching Characteristics ($T_A = -40^\circ$ to $+85^\circ\text{C}$, $V_{DD} = 1.5\text{V}$ to 1.8V)

Parameter	Description	Min.	Typ. ⁽¹⁾	Max.	Units
tPZH, tPZL	Line Enable Time - SEL to AN, BN, CN	0.5	-	8.0	ns
tPHZ, tPLZ	Line Disable Time - SEL to AN, BN, CN	0.5	-	8.0	
t _{b-b}	Bit-to-bit skew within the same differential pair			15	ps
t _{ch-ch}	Channel-to-channel skew			20	

Note:

1. Typical values are at $V_{DD} = 1.8\text{V}$, $T_A = 25^\circ\text{C}$ ambient and maximum loading.

Test Circuit for Electrical Characteristics⁽¹⁻⁵⁾

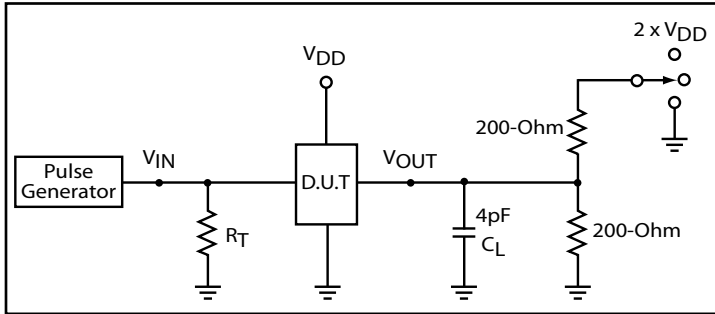

Switch Positions

Test	Switch
tPLZ, tPZL	2 x VDD
tPHZ, tPZH	GND
Prop Delay	Open

Notes:

1. C_L = Load capacitance: includes jig and probe capacitance.
2. R_T = Termination resistance: should be equal to Z_{OUT} of the Pulse Generator
3. Output 1 is for an output with internal conditions such that the output is low except when disabled by the output control.
 output 2 is for an output with internal conditions such that the output is high except when disabled by the output control.
4. All input impulses are supplied by generators having the following characteristics: $PRR \leq \text{MHz}$, $Z_O = 50\Omega$, $t_R \leq 2.5\text{ns}$, $t_F \leq 2.5\text{ns}$.
5. The outputs are measured one at a time with one transition per measurement.

Switching Waveforms

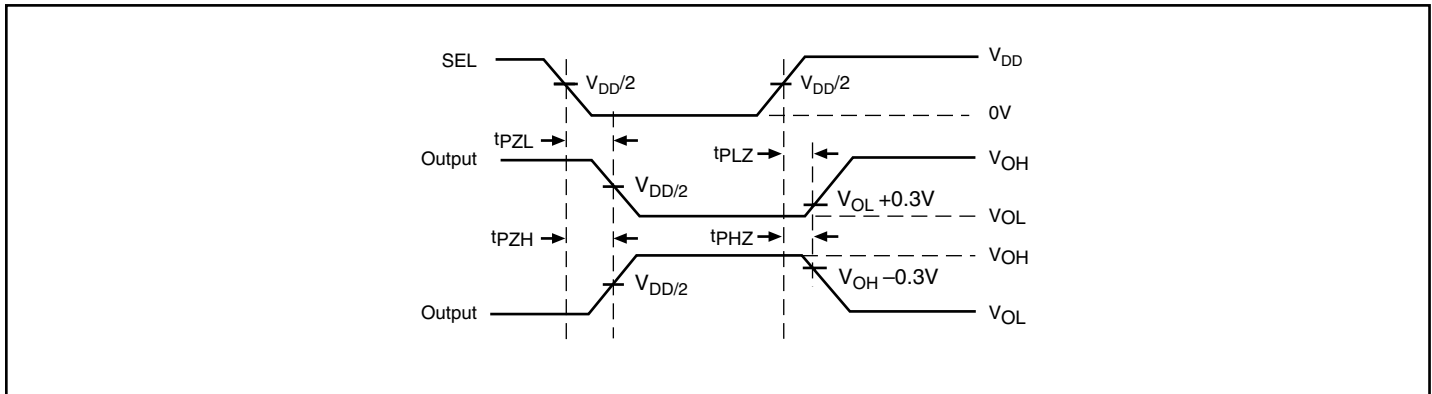

Voltage Waveforms Enable and Disable Times

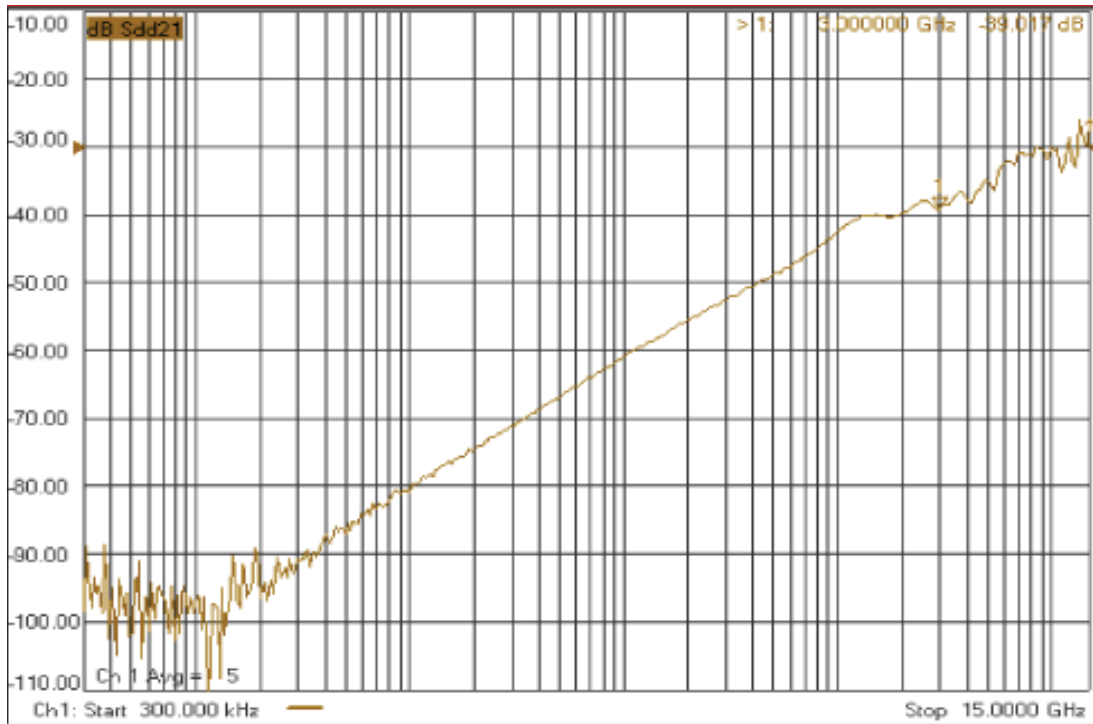

Crosstalk

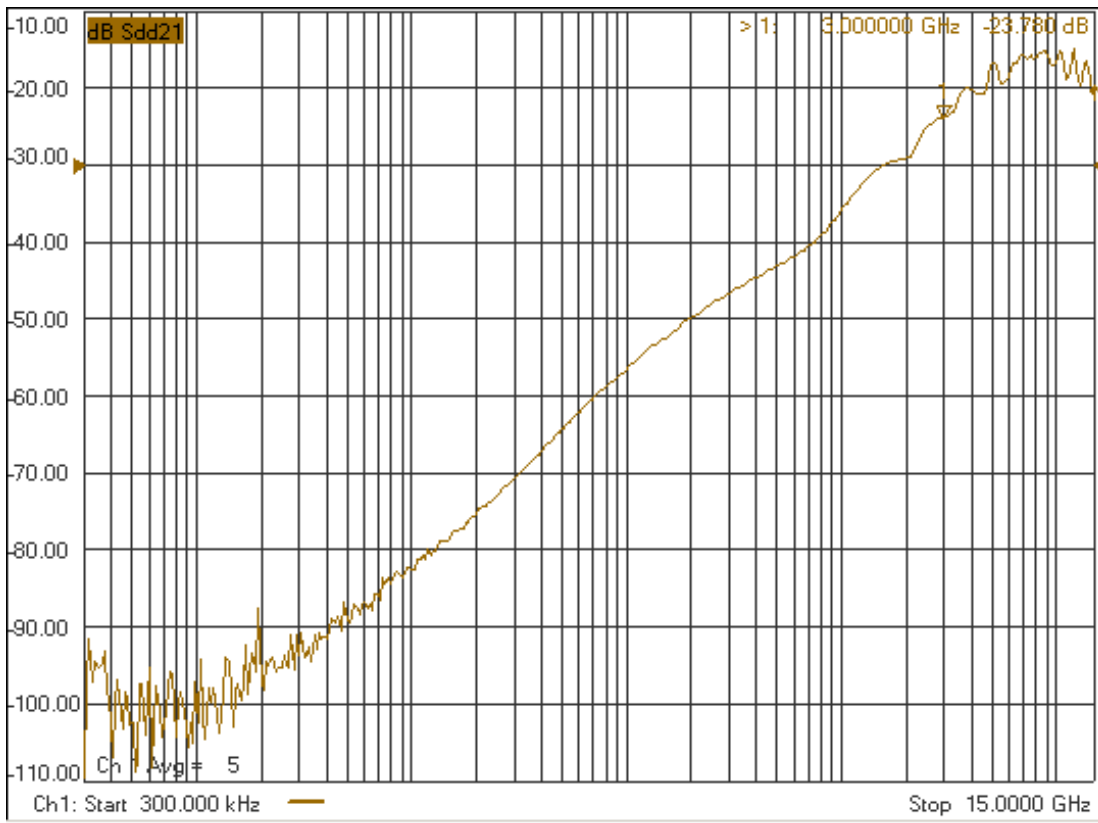

Off Isolation

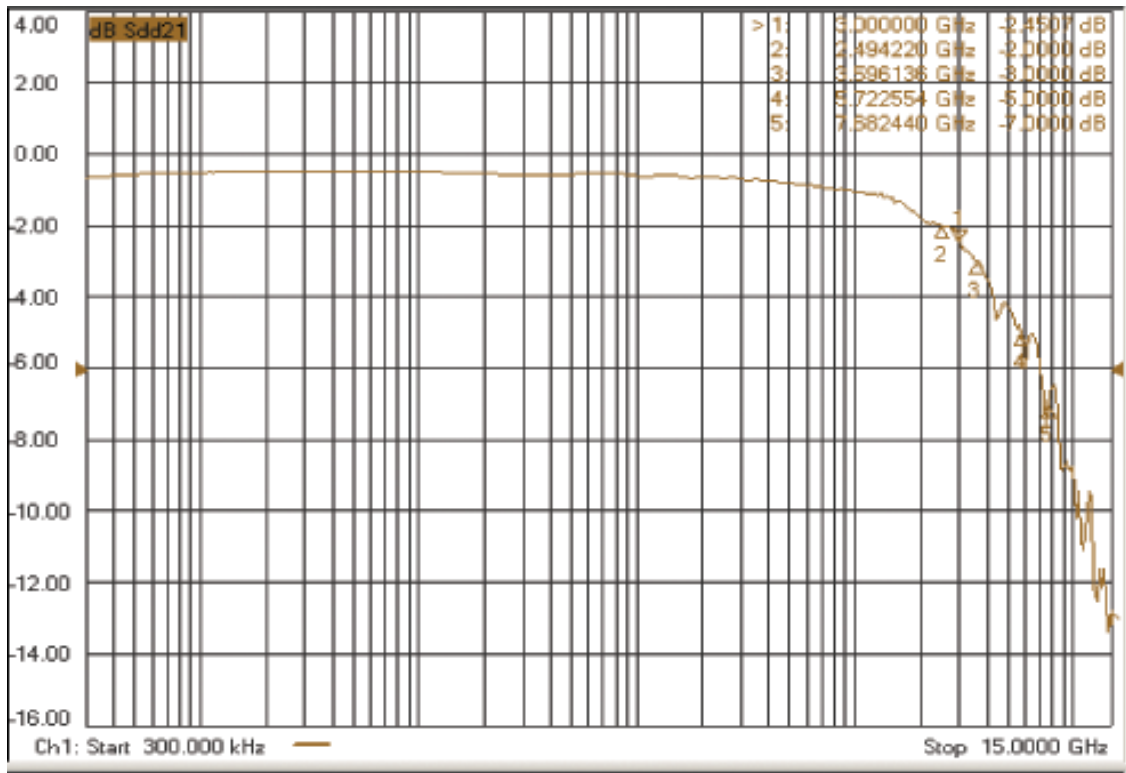

Insertion Loss

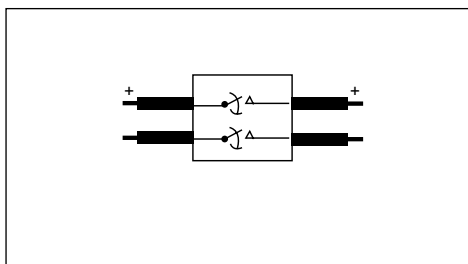

Diff. Insertion Loss and Return Test Circuit

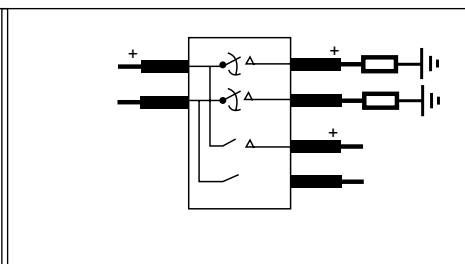

Diff. Off Isolation Test Circuit

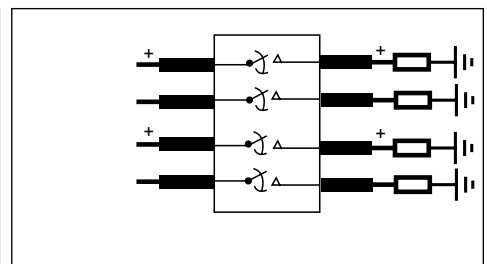

Diff. Near End Xtalk Test Circuit

Packaging Mechanical: 28-Pin TQFN (ZH)

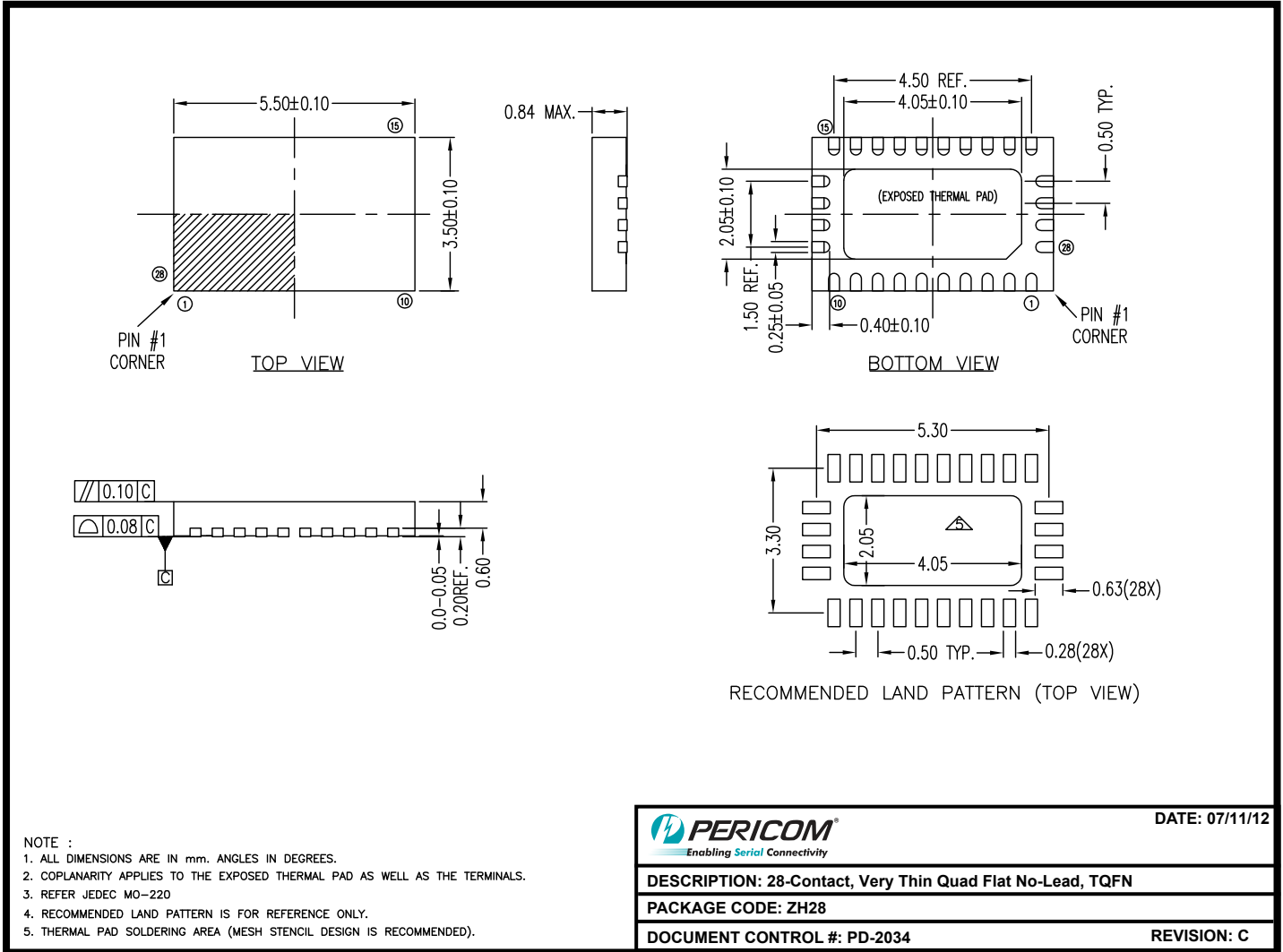

12-0419

Note:

- For latest package info, please check: <http://www.pericom.com/products/packaging/mechanicals.php>

Ordering Information

Ordering Code	Package Code	Package Type
PI2PCIE2212ZHE	ZH	Pb-free & Green, 28-Contact TQFN

Notes:

- Thermal characteristics can be found on the company web site at www.pericom.com/packaging/
- E = Pb-free and Green
- Adding an X suffix = Tape/Reel

X-ON Electronics

Largest Supplier of Electrical and Electronic Components

Click to view similar products for [Multiplexer Switch ICs](#) category:

Click to view products by [Diodes Incorporated](#) manufacturer:

Other Similar products are found below :

[NLV74HC4066ADR2G](#) [HEF4051BP](#) [MC74HC4067ADTG](#) [DG508AAK/883B](#) [NLV14051BDG](#) [016400E](#) [PI3V512QE](#) [7705201EC](#)
[PI2SSD3212NCE](#) [PI3L100QE](#) [NLAS3257CMX2TCG](#) [PI5A3157BC6EX](#) [PI3V512QEX](#) [PI3DBS16213ZLEX](#) [PI3DBS16415ZHEX](#)
[PS509LEX](#) [MUX36S16IRSNR](#) [74LVC1G3157GM-Q10X](#) [TC7W53FK,LF](#) [CD4053BM96](#) [MC74HC4053ADWR2G](#) [MAX4051AEEE+](#)
[PI3L720ZHEX](#) [ADG1404YRUZ-REEL7](#) [ADG1208YRZ-REEL7](#) [CD4053BPWRG4](#) [ADG658TRUZ-EP](#) [FSA1256L8X_F113](#) [PI5V330QE](#)
[PI5V331QE](#) [5962-8771601EA](#) [ADG5249FBRUZ](#) [ADG1438BRUZ](#) [ADG5207BCPZ-RL7](#) [ADW54003-0](#) [AD7506JNZ](#) [AD7506KNZ](#)
[AD7506SQ](#) [AD8170AR](#) [AD8183ARUZ](#) [AD8184ANZ](#) [AD8185ARUZ](#) [AD8187ARUZ](#) [AD8188ARUZ](#) [AD8189ARUZ](#) [ADG1208YRUZ-](#)
[REEL7](#) [ADG1409YCPZ-REEL7](#) [ADG5209FBRUZ](#) [ADG1408YRUZ-REEL7](#) [ADG659YRUZ-REEL7](#)