

1.8V, PCI Express Gen2 Compliant, 4-Differential Channel, 2:1 Mux/DeMux Switch

Features

- 4 Differential Channel, 2:1 Mux/DeMux
- PCI Express, Gen 2 Performance, 5.0Gbps
- Low Bit-to-Bit Skew, 7ps max (between '+' and '-' bits)
- Low Crosstalk: -23dB@3 GHz
- Low Off Isolation: -23dB@3 GHz
- V_{DD} Operating Range: +1.5V to +1.8V ±10%
- ESD Tolerance: 5kV HBM I/O; 2kV HBM select pin
- Low channel-to-channel skew, 35ps max
- Packaging (Pb-free & Green):
 - 42-contact, TQFN (ZH42)

Description

Pericom Semiconductor's PI2PCIE2412 is an 8 to 4 differential channel multiplexer/demultiplexer switch. This solution can switch 2 full PCI Express, Gen2, lanes to one of two locations. Using a unique design technique, Pericom has been able to minimize the impedance of the switch such that the attenuation observed through the switch is negligible. The unique design technique also offers a layout targeted for PCI Express signals, which minimizes the channel to channel skew as well as channel to channel crosstalk as required by the PCI Express specification.

Application

Routing of PCI-Express, Gen2, signals with low signal attenuation.

Block Diagram

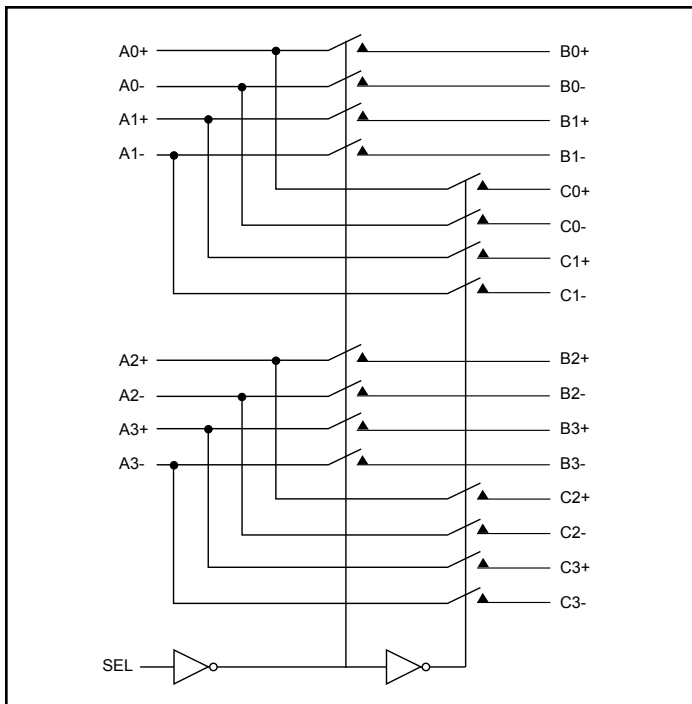

Truth Table

Function	SEL
A _N to B _N	L
A _N to C _N	H

Pin Description

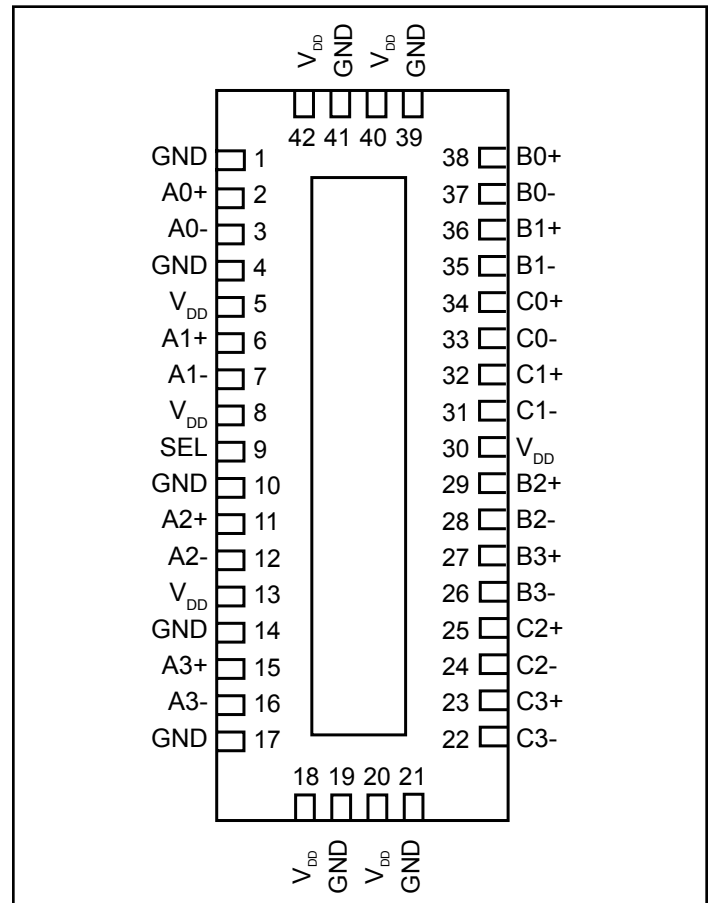

Pin Description

Pin #	Pin Name	I/O	Description
2 3	A0+ A0-	I/O	Signal I/O, Channel 0, Port A
6 7	A1+ A1-	I/O	Signal I/O, Channel 1, Port A
11 12	A2+ A2-	I/O	Signal I/O, Channel 2, Port A
15 16	A3+ A3-	I/O	Signal I/O, Channel 3, Port A
38 37	B0+ B0-	I/O	Signal I/O, Channel 0, Port B
36 35	B1+ B1-	I/O	Signal I/O, Channel 1, Port B
29 28	B2+ B2-	I/O	Signal I/O, Channel 2, Port B
27 26	B3+ B3-	I/O	Signal I/O, Channel 3, Port B
34 33	C0+ C0-	I/O	Signal I/O, Channel 0, Port C
32 31	C1+ C1-	I/O	Signal I/O, Channel 1, Port C
25 24	C2+ C2-	I/O	Signal I/O, Channel 2, Port C
23 22	C3+ C3-	I/O	Signal I/O, Channel 3, Port C
9	SEL	I	Operation mode Select (when SEL=0: A→B, when SEL=1: A→C)
5, 8, 13, 18, 20, 30, 40, 42	V _{DD}	Pwr	1.5V to 1.8V (±0.1V) Positive Supply Voltage
1, 4, 10, 14, 17, 19, 21, 39, 41, Center Pad	GND	Pwr	Power ground

Maximum Ratings

(Above which useful life may be impaired. For user guidelines, not tested.)

Storage Temperature	-65°C to +150°C
Supply Voltage to Ground Potential	-0.5V to +2.5V
DC Input Voltage	-0.5V to V _{DD}
DC Output Current	120mA
Power Dissipation	0.5W

Note: Stresses greater than those listed under MAXIMUM RATINGS may cause permanent damage to the device. This is a stress rating only and functional operation of the device at these or any other conditions above those indicated in the operational sections of this specification is not implied. Exposure to absolute maximum rating conditions for extended periods may affect reliability.

DC Electrical Characteristics for Switching over Operating Range

(T_A = -40°C to +85°C, V_{DD} = 1.5V to 1.8V ±10%)

Parameters	Description	Test Conditions ⁽¹⁾	Min	Typ ⁽²⁾	Max	Units
V _{IH}	Input HIGH Voltage	Guaranteed HIGH level	0.65 x V _{DD}			V
V _{IL}	Input LOW Voltage	Guaranteed LOW level	-0.5		0.35 x V _{DD}	
V _{IK}	Clamp Diode Voltage	V _{DD} = Max., I _{IN} = -18mA		-0.7	-1.2	
I _{IH}	Input HIGH Current	V _{DD} = Max., V _{IN} = V _{DD}			±5	µA
I _{IL}	Input LOW Current	V _{DD} = Max., V _{IN} = GND			±5	

Power Supply Characteristics

Parameters	Description	Test Conditions ⁽¹⁾	Min.	Typ. ⁽²⁾	Max.	Units
I _{DD}	Quiescent Power Supply Current	V _{DD} = Max., V _{IN} = GND or V _{DD}			350	µA

Switching Characteristics

(T_A = -40° to +85°C, V_{DD} = 1.8V±10%)

Parameters	Description	Min.	Max.	Units
t _{PZH} , t _{PZL}	Line Enable Time - SEL to A _N , B _N , C _N	0.5	8.0	ns
t _{PHZ} , t _{PLZ}	Line Disable Time - SEL to A _N , B _N , C _N	0.5	8.0	
t _{b-b}	Bit-to-bit skew within the same differential pair		7	ps
t _{ch-ch}	Channel-to-channel skew		35	ps

Dynamic Electrical Characteristics Over the Operating Range

(T_A = -40° to +85°C, V_{DD} = 1.8V±10%, GND=0V)

Parameters	Description	Test Conditions	Min.	Typ. ⁽²⁾	Max.	Units
X _{TALK}	Crosstalk	See Fig. 1 for Measurement Setup, f = 3 GHz f = 100 MHz		-23dB -58dB		dB
O _{IRR}	OFF Isolation	See Fig. 2 for Measurement Setup, f = 3 GHz f = 100 MHz		-23dB -58dB		
I _{LOSS}	Differential Insertion Loss	f = 3 GHz		-2		dB
BW	Bandwidth -3dB			4.1		GHz

Notes:

- For Max. or Min. conditions, use appropriate value specified under Electrical Characteristics for the applicable device type.
- Typical values are at V_{DD} = 1.8V, T_A = 25°C ambient and maximum loading.

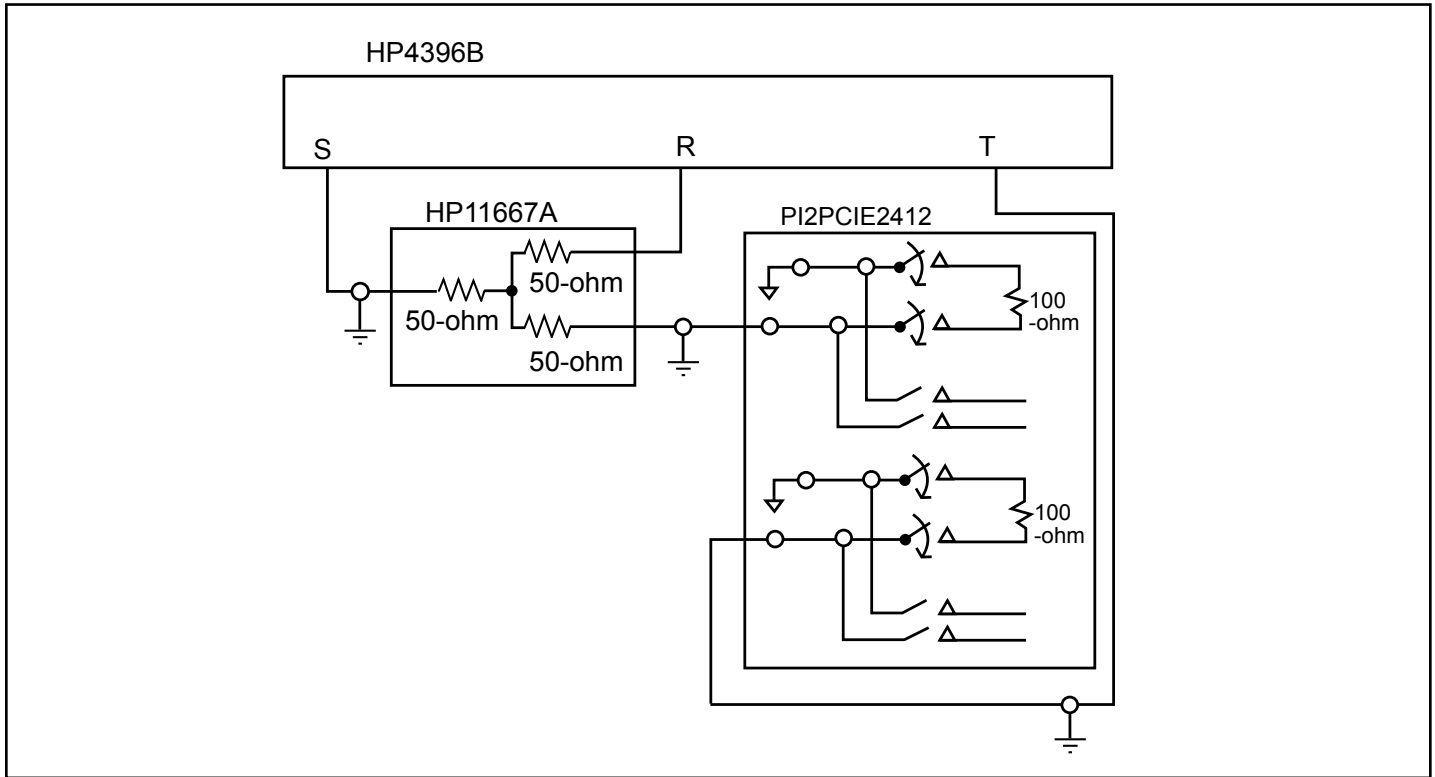

Fig 1. Crosstalk Setup

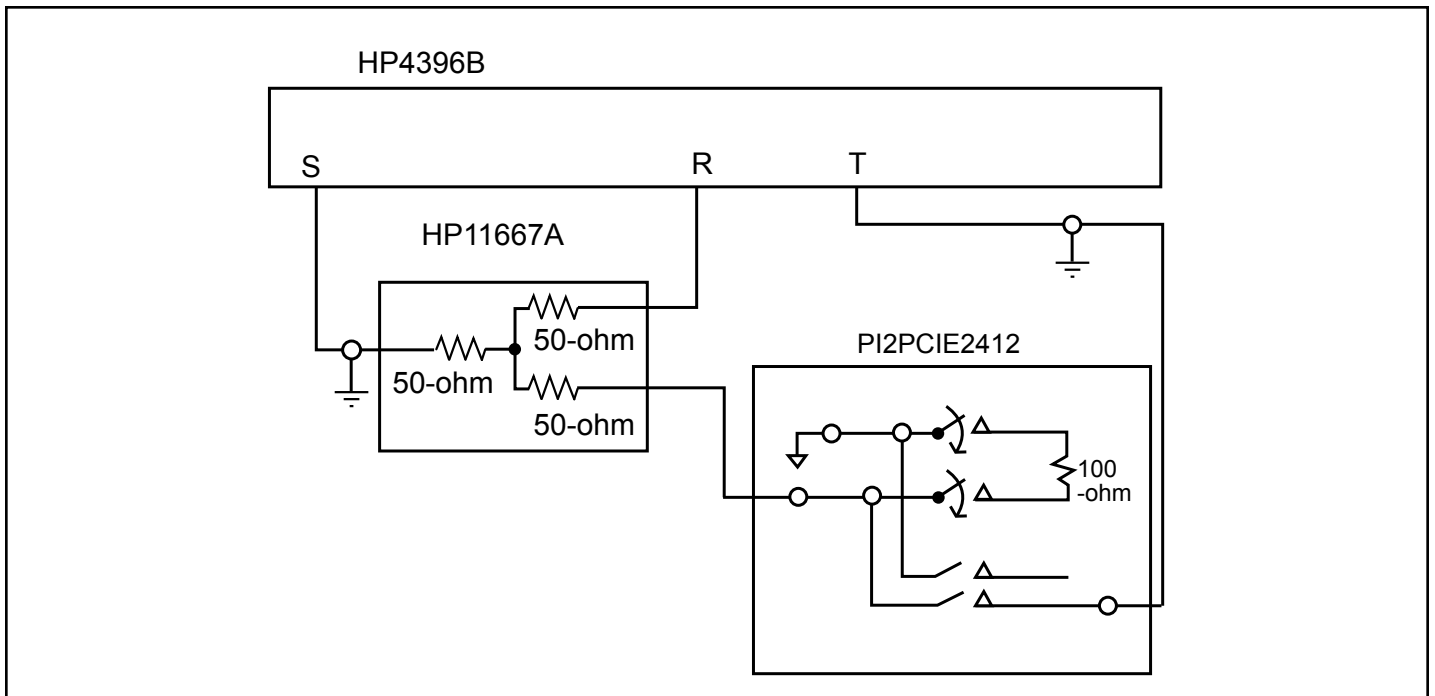

Fig 2. Off-isolation setup

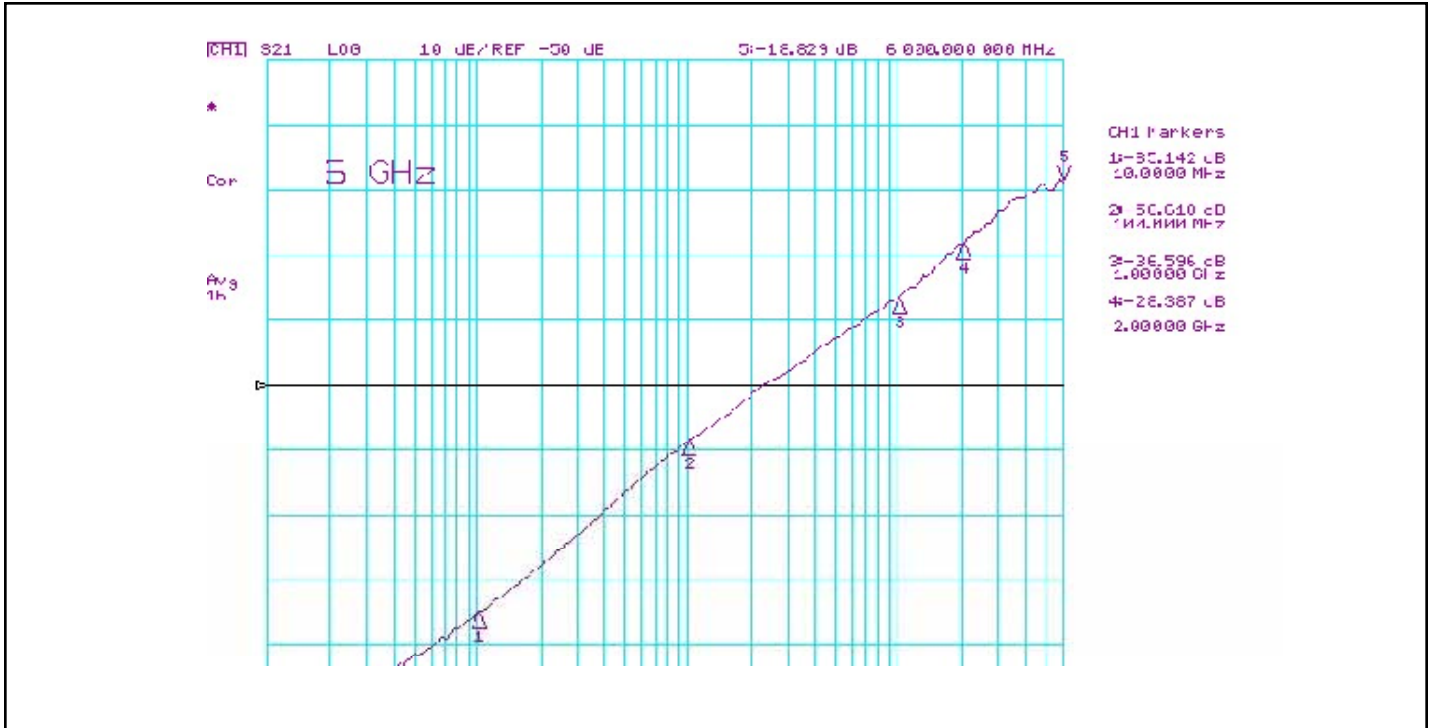

Fig 3. Crosstalk

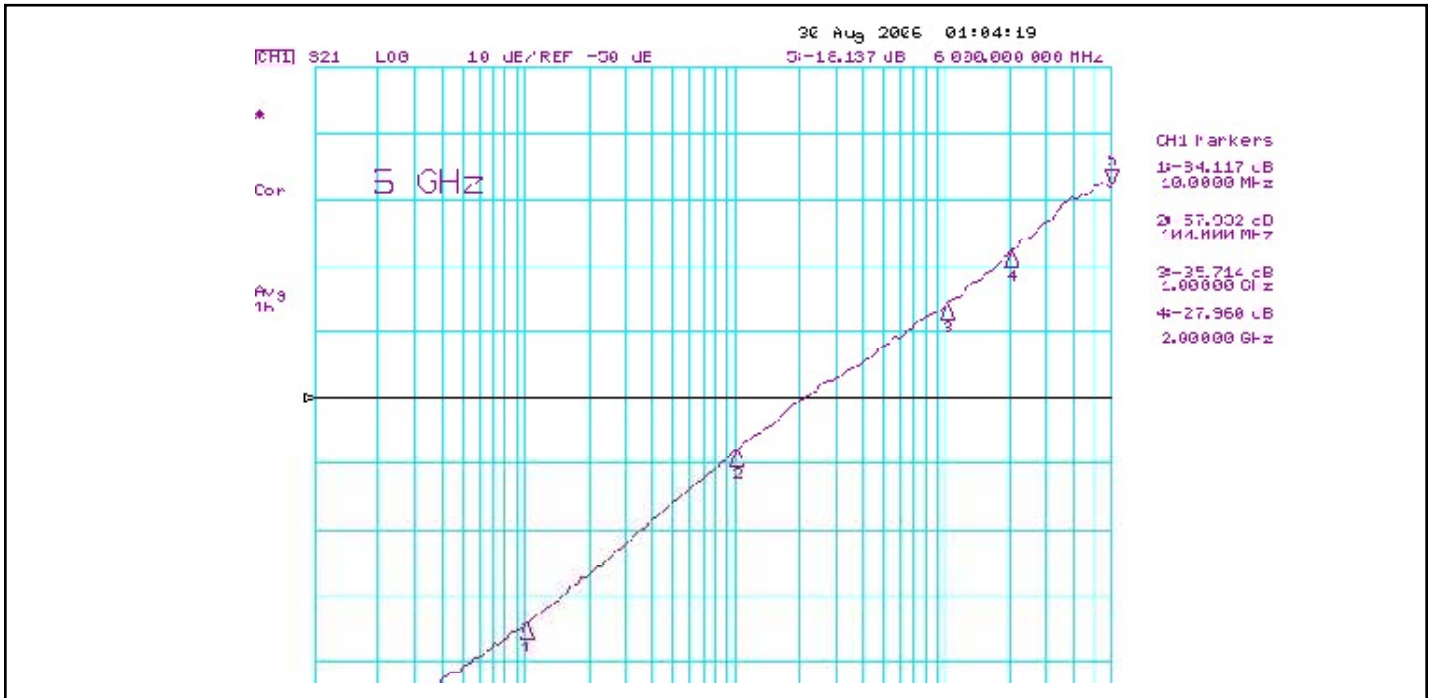

Fig 4. Off Isolation

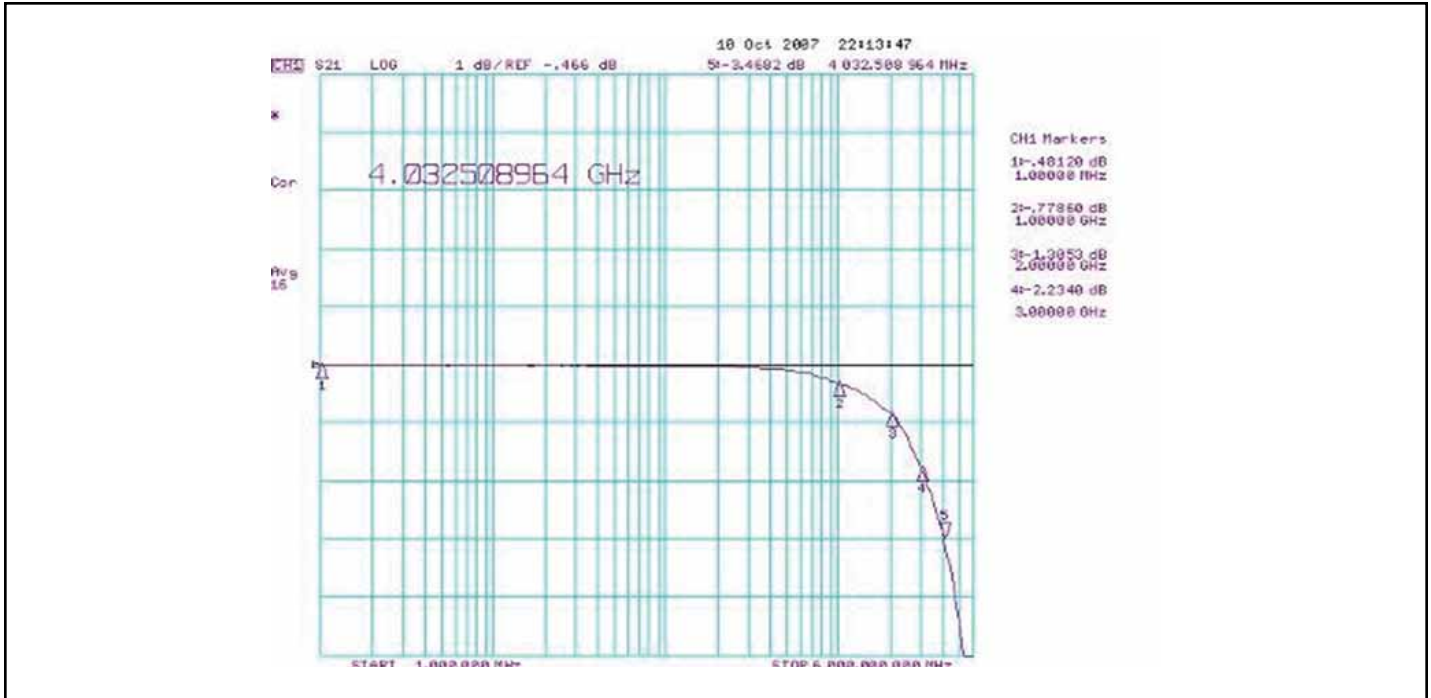
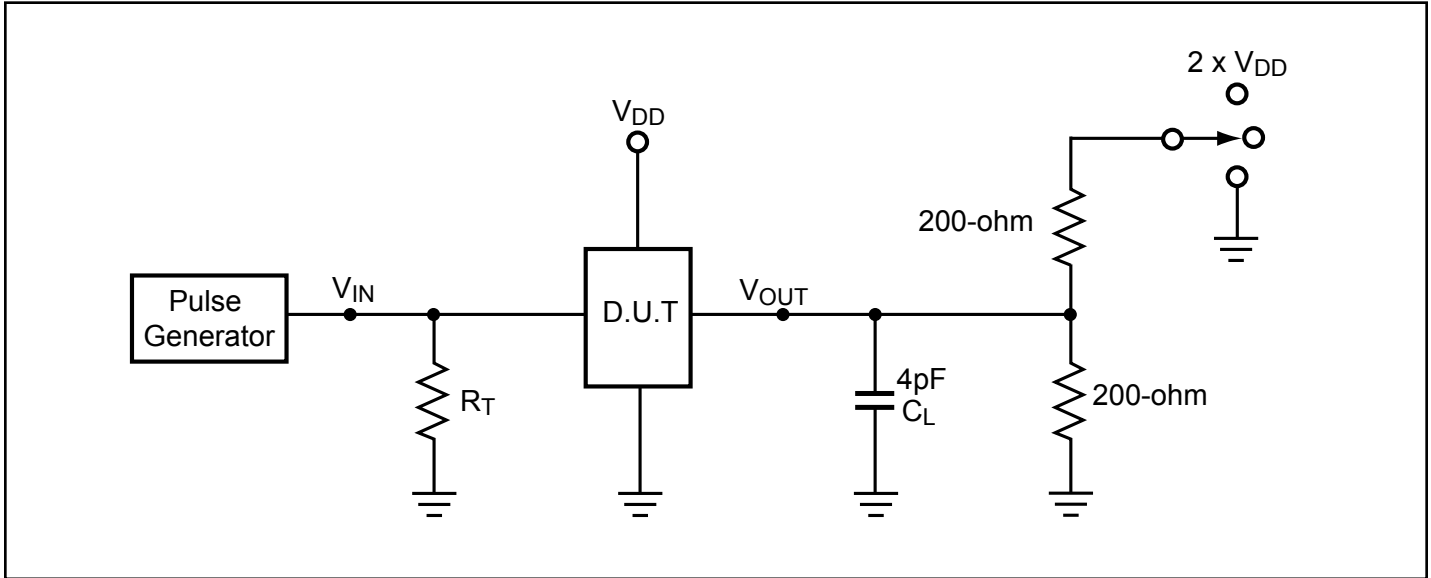

Fig 5. Insertion Loss

Test Circuit for Electrical Characteristics⁽¹⁻⁵⁾



Notes:

1. C_L = Load capacitance: includes jig and probe capacitance.
2. R_T = Termination resistance: should be equal to Z_{OUT} of the Pulse Generator
3. Output 1 is for an output with internal conditions such that the output is low except when disabled by the output control.
 output 2 is for an output with internal conditions such that the output is high except when disabled by the output control.
4. All input impulses are supplied by generators having the following characteristics: $PRR \leq \text{MHz}$, $Z_O = 50\Omega$, $t_R \leq 2.5\text{ns}$, $t_F \leq 2.5\text{ns}$.
5. The outputs are measured one at a time with one transition per measurement.

Switching Waveforms

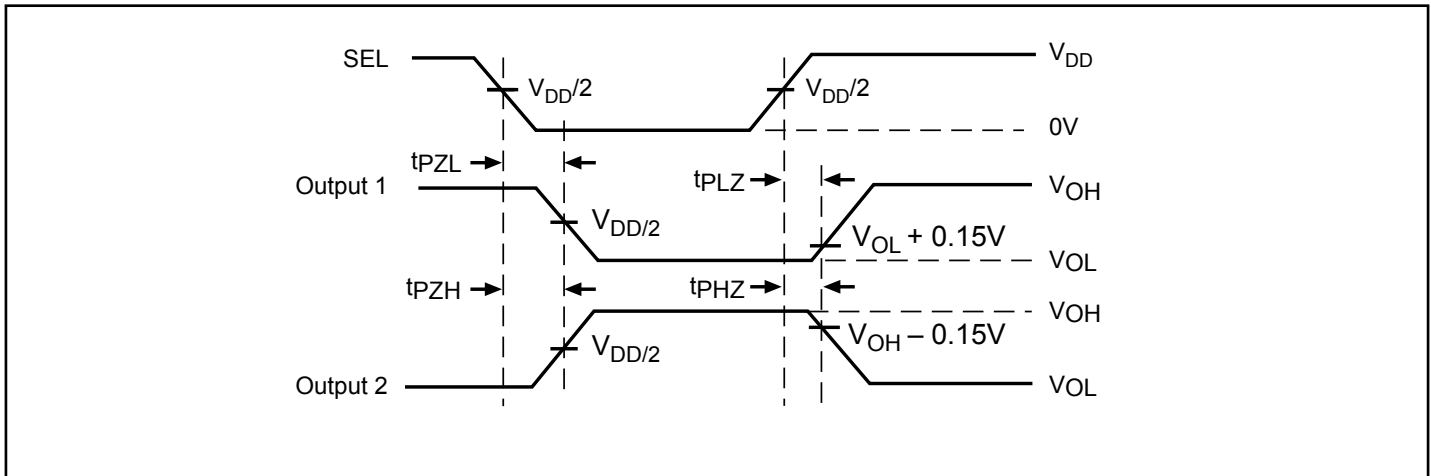

Voltage Waveforms Enable and Disable Times

Switch Positions

Test	Switch
t_{PLZ} , t_{PZL} (output on B-side)	$2 \times V_{DD}$
t_{PHZ} , t_{PZH} (output on B-side)	GND
Prop Delay	Open

Test Circuit for Dynamic Electrical Characteristics

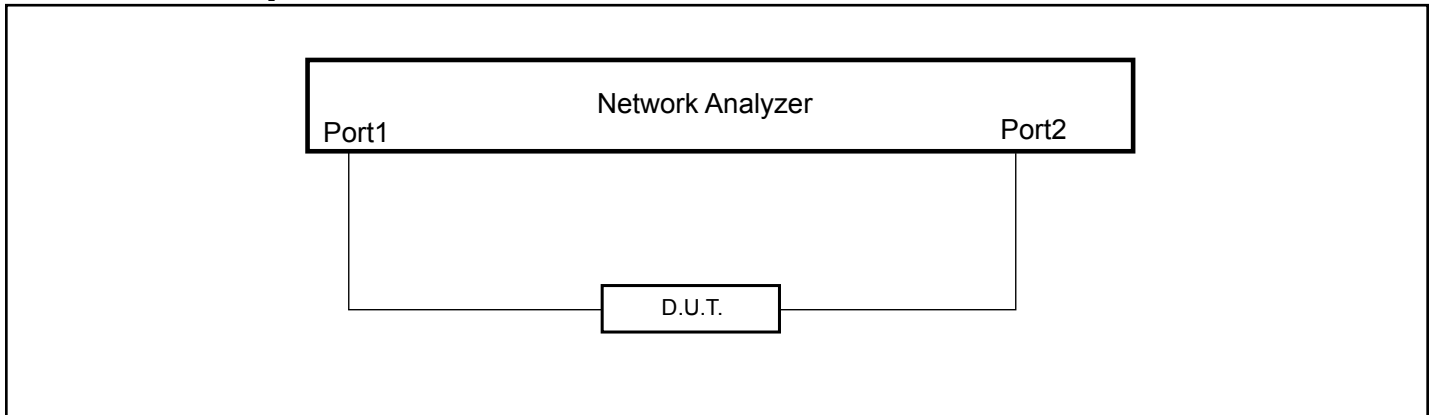

Applications Information

Rail-to-Rail is a registered trademark of Nippon Motorola, Ltd

PCI Express Application Specific Measurements and Test Set-up



Figure 5: Test Setup

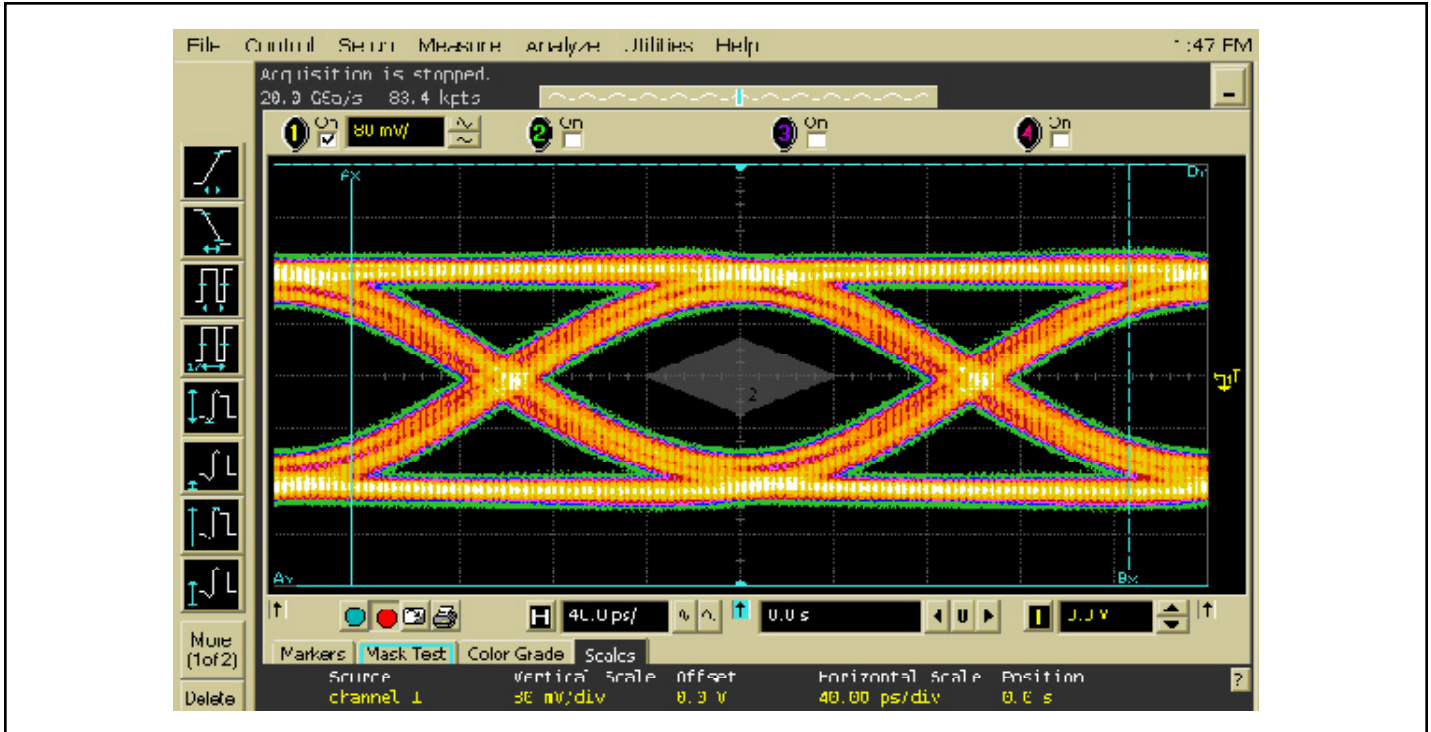

Figure 6: 5 Gbps RX signal eye of the PCI-SIG compliance software test using PI2PCIE2412 + 16" test card

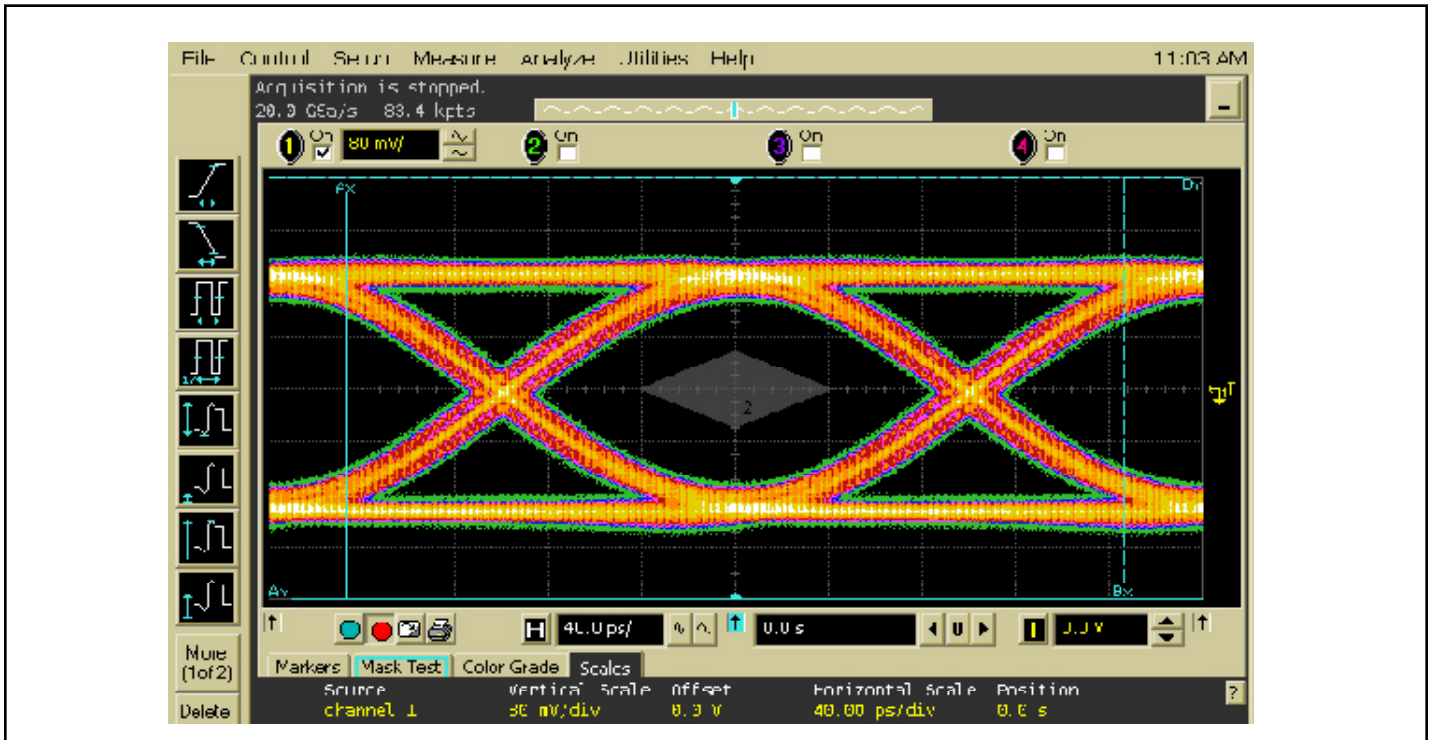
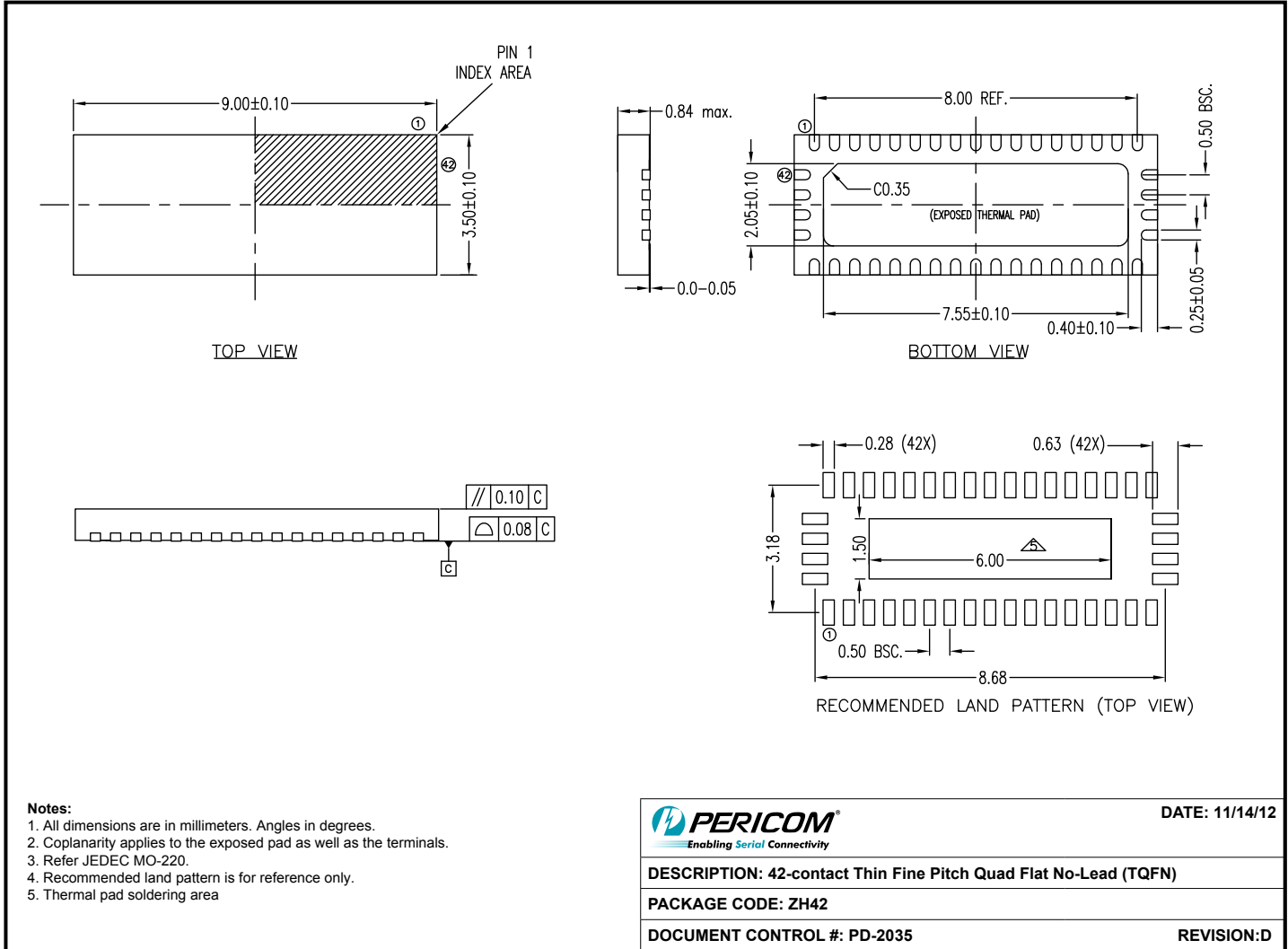

Figure 7: 5 Gbps RX signal eye of the PCI-SIG compliance software test with no switch + w/ 16" test card

Packaging Mechanical: 42-Contact TQFN (ZH)



12-0529

Ordering Information

Ordering Code	Package Code	Package Description
PI2PCIE2412ZHEX	ZH	42-contact, Thin Fine Pitch Quad Flat No-Lead (TQFN)

Notes:

- Thermal characteristics can be found on the company web site at www.pericom.com/packaging/
- "E" denotes Pb-free and Green
- Adding an "X" at the end of the ordering code denotes tape and reel packaging

X-ON Electronics

Largest Supplier of Electrical and Electronic Components

Click to view similar products for [Multiplexer Switch ICs](#) category:

Click to view products by [Diodes Incorporated](#) manufacturer:

Other Similar products are found below :

[NLV74HC4066ADR2G](#) [HEF4051BP](#) [MC74HC4067ADTG](#) [DG508AAK/883B](#) [NLV14051BDG](#) [016400E](#) [PI3V512QE](#) [7705201EC](#)
[PI2SSD3212NCE](#) [PI3L100QE](#) [NLAS3257CMX2TCG](#) [PI5A3157BC6EX](#) [PI3V512QEX](#) [PI3DBS16213ZLEX](#) [PI3DBS16415ZHEX](#)
[PS509LEX](#) [MUX36S16IRSNR](#) [74LVC1G3157GM-Q10X](#) [TC7W53FK,LF](#) [CD4053BM96](#) [MC74HC4053ADWR2G](#) [MAX4051AEEE+](#)
[PI3L720ZHEX](#) [ADG1404YRUZ-REEL7](#) [ADG1208YRZ-REEL7](#) [CD4053BPWRG4](#) [ADG658TRUZ-EP](#) [FSA1256L8X_F113](#) [PI5V330QE](#)
[PI5V331QE](#) [5962-8771601EA](#) [ADG5249FBRUZ](#) [ADG1438BRUZ](#) [ADG5207BCPZ-RL7](#) [ADW54003-0](#) [AD7506JNZ](#) [AD7506KNZ](#)
[AD7506SQ](#) [AD8170AR](#) [AD8183ARUZ](#) [AD8184ANZ](#) [AD8185ARUZ](#) [AD8187ARUZ](#) [AD8188ARUZ](#) [AD8189ARUZ](#) [ADG1208YRUZ-](#)
[REEL7](#) [ADG1409YCPZ-REEL7](#) [ADG5209FBRUZ](#) [ADG1408YRUZ-REEL7](#) [ADG659YRUZ-REEL7](#)