

1.8/3.3V High-Bandwidth 6-channel, 2:1 Mux/DeMux

Features

- CMOS Technology for bus and analog applications
- Low propagation delay
- Low typical On-Resistance: 5Ω
- Signal passing bandwidth, 380 MHz
- Wide V_{DD} range: 1.65V to 3.6V
- Rail-to-Rail signal range
- High Off Isolation: -66dB @ 10MHz
- Crosstalk Rejection reduces signal distortion:
-60dB @ 10MHz
- Break-Before-Make Switching
- Extended Industrial Temperature Range:
-40°C to 85°C
- ESD protection : 2.5kV(HBM)
- Totally Lead-Free & Fully RoHS Compliant (Notes 1 & 2)
- Halogen and Antimony Free. "Green" Device (Note 3)
- For automotive applications requiring specific change control (i.e. parts qualified to AEC-Q100/101/200, PPAP capable, and manufactured in IATF 16949 certified facilities), please [contact us](#) or your local Diodes representative.
- <https://www.diodes.com/quality/product-definitions/>
- Packaging (Pb-free & Green):
 - 24-pin TQFN (ZD), 4mm x 4mm

Applications

- SD-SDIO and MMC Two-Port MUX
- qSPI Two-Port MUX
- Audio and Video Signal Routing

Description

The PI3A27518 is a 6-channel, 1:2 multiplexer/demultiplexer. The COMx port can be configured to connect with NOx or NCx ports in 4 different modes (refer to Truth Table for details).

The PI3A27518 has a wide operating voltage range, very low power consumption and small packaging.

The device can be used as an analog switch or as a low-delay bus switch. The PI3A27518 supports a wide operating power supply voltage, 1.65V to 3.6V and has an On-Resistance of 5Ω at +3.3V.

Break-before-make switching prevents both switches from being enabled simultaneously. This eliminates signal disruption during switching.

Notes:

1. No purposely added lead. Fully EU Directive 2002/95/EC (RoHS), 2011/65/EU (RoHS 2) & 2015/863/EU (RoHS 3) compliant.
2. See <https://www.diodes.com/quality/lead-free/> for more information about Diodes Incorporated's definitions of Halogen- and Antimony-free, "Green" and Lead-free.
3. Halogen- and Antimony-free "Green" products are defined as those which contain <900ppm bromine, <900ppm chlorine (<1500ppm total Br + Cl) and <1000ppm antimony compounds.

Block Diagram

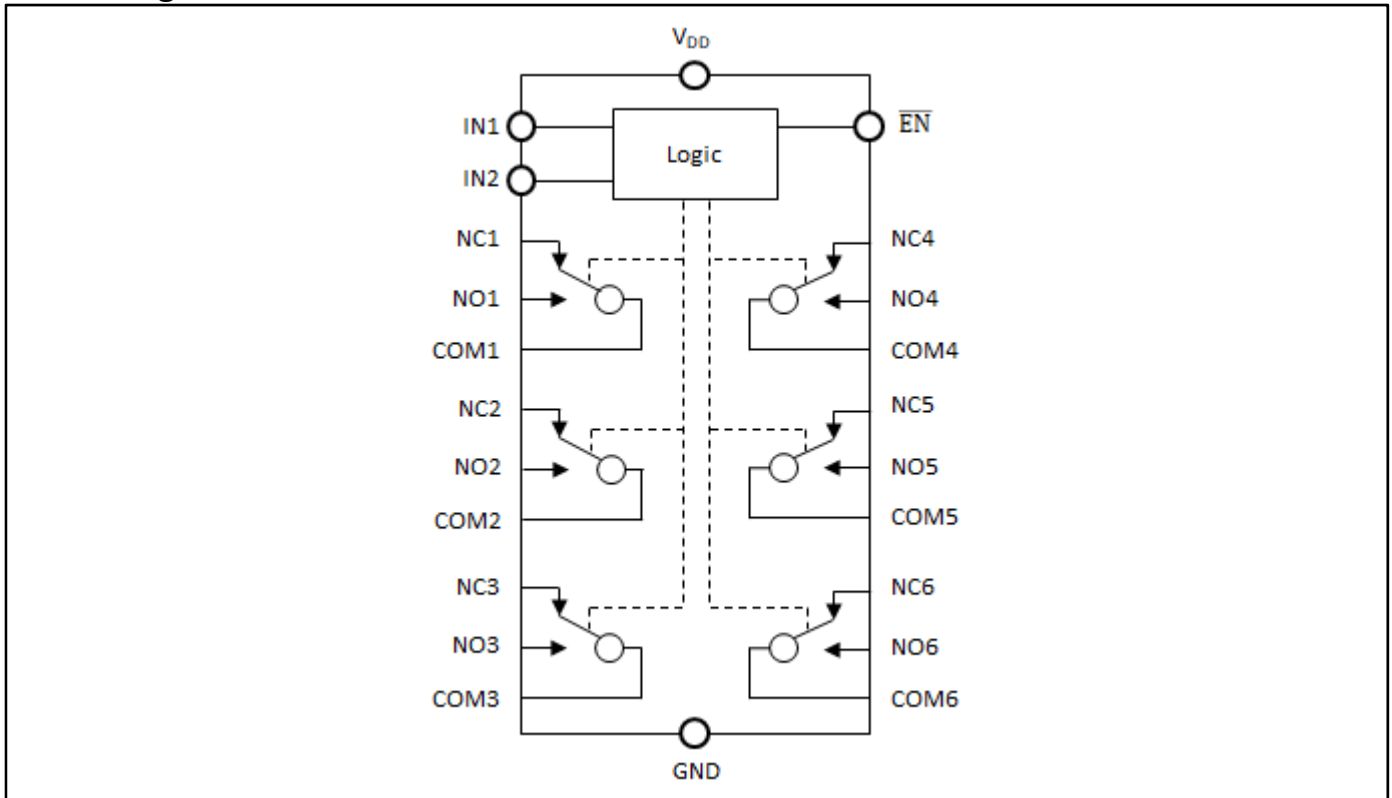

Function Table

Select Input			Function
EN	IN1	IN2	
1	X	X	All Channels are OFF
0	0	0	NC _{1,2,3} Connected to COM _{1,2,3} NC _{4,5,6} Connected to COM _{4,5,6}
0	1	0	NO _{1,2,3} Connected to COM _{1,2,3} NC _{4,5,6} Connected to COM _{4,5,6}
0	0	1	NC _{1,2,3} Connected to COM _{1,2,3} NO _{4,5,6} Connected to COM _{4,5,6}
0	1	1	NO _{1,2,3} Connected to COM _{1,2,3} NO _{4,5,6} Connected to COM _{4,5,6}

Pin Configuration (Top view)

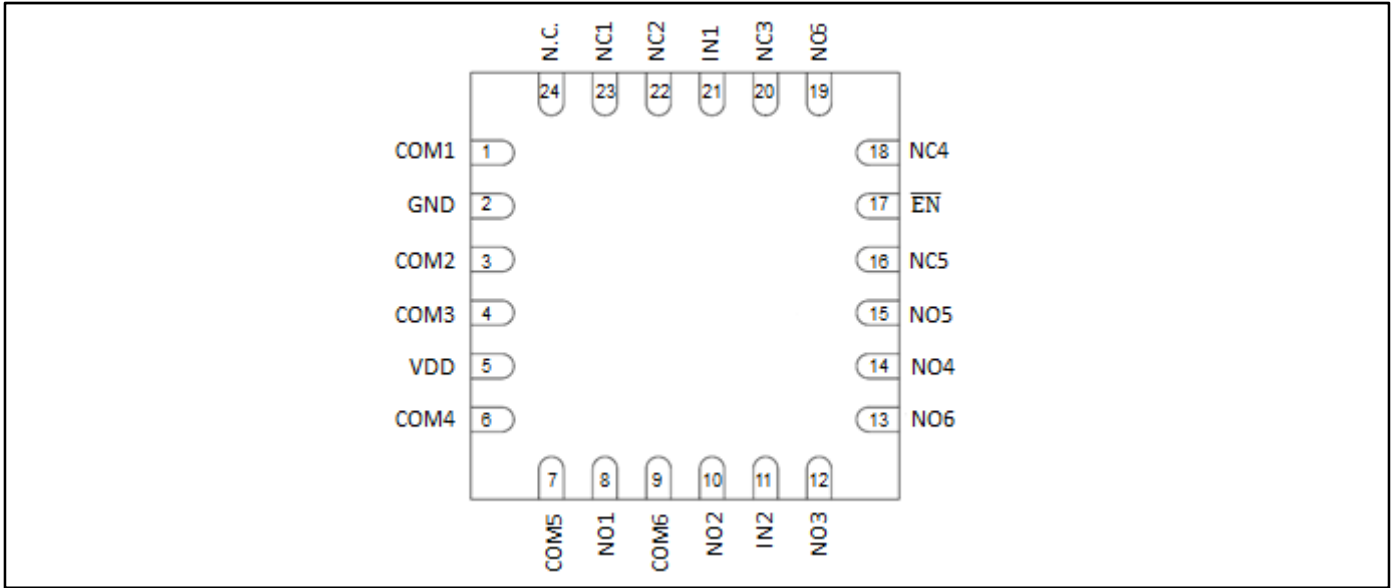

Pin Description

Pin#	Name	Description
1	COM1	Common Signal Path
2	GND	Ground
3	COM2	Common Signal Path
4	COM3	Common Signal Path
5	VDD	Positive Power Supply
6	COM4	Common Signal Path
7	COM5	Common Signal Path
8	NO1	Signal Path – Normal Open
9	COM6	Common Signal Path
10	NO2	Data Port (Normally open)
11	IN2	Select Input 2
12	NO3	Signal Path – Normal Open
13	NO6	Signal Path – Normal Open
14	NO4	Signal Path – Normal Open
15	NO5	Signal Path – Normal Open
16	NC5	Signal Path – Normal Closed
17	EN	Enable Input, Low Active
18	NC4	Signal Path – Normal Closed
19	NC6	Signal Path – Normal Closed
20	NC3	Signal Path – Normal Closed
21	IN1	Select Input 1
22	NC2	Signal Path – Normal Closed
23	NC1	Signal Path – Normal Closed
24	N.C	No connect

Maximum Ratings

Storage Temperature.....	-65°C to +150°C
Ambient Temperature with Power Applied.....	-40°C to +85°C
Supply Voltage V_{DD}	-0.5V to +4.6V
Control Input Voltage V_{INx}	0V to +4.6V
DC Input Voltage V_{INPUT}	-0.5V to +4.6V
Continuous Current NO_NC_COM_.....	±50mA
ESD(HBM)	2.5kV
ESD(CDM)	1.5kV

Note:

Stresses greater than those listed under MAXIMUM RATINGS may cause permanent damage to the device. This is a stress rating only and functional operation of the device at these or any other conditions above those indicated in the operational sections of this specification is not implied. Exposure to absolute maximum rating conditions for extended periods may affect reliability. The input and output negative voltage ratings may be exceeded if the input and output diode current ratings are observed. Control input must be held HIGH or LOW; it must not float.

Recommended Operating Conditions

Symbol	Parameter	Conditions	Min.	Typ.	Max.	Unit
V_{DD}	Operating Voltage	-	1.65	-	3.6	V
V_{IN}	Control Input Voltage	-	0	-	V_{DD}	V
V_{INPUT}	Switch Input Voltage	-	-0.3	-	V_{DD}	V
T_A	Operating Temperature	-	-40	25	85	°C

DC Electrical Characteristics

+3.3V Supply ($V_{DD} = 3V$ to $3.6V$, $T_A = -40°C$ to $85°C$, unless otherwise noted. Typical values are at $3.3V$ and $+25°C$.)

Symbol	Parameter	Test Conditions	TEMP	Min.	Typ.	Max.	Units
ANALOG SWITCH							
V_{NO} , V_{NC} , V_{COM}	Analog Signal Range		-40°C to 85°C	0	-	V_{DD}	V
R_{ON}	On-Resistance	$V_{DD} = 3V$, $I_{COM} = -32mA$, $0 \leq V_{NO}$ or $V_{NC} \leq V_{DD}$, <i>Test Circuit 1</i>	+25°C -40°C to 85°C	-	4.4	5.2	Ω
ΔR_{ON}	On-Resistance Match Between Channels	$V_{DD} = 3V$, $I_{COM} = -32mA$, V_{NO} or $V_{NC} = 2.1V$, <i>Test Circuit 1</i>	+25°C -40°C to 85°C	-	0.3	0.7	Ω
R_{ONF}	On-Resistance Flatness	$V_{DD} = 3.3V$, $I_{COM} = -32mA$, $V_{NO} = 0.15V$ or $V_{NC} = 3.15V$, <i>Test Circuit 1</i>	+25°C -40°C to 85°C	-	0.95	2.1	Ω
$I_{OFF(NO)}$ or $I_{OFF(NC)}$	NC/NO Channel-Off Leakage Current	$V_{DD} = 3.6V$, V_{NO} or $V_{NC} = 3V$ & $V_{COM} = 1V$ or V_{NO} or $V_{NC} = 1V$ & $V_{COM} = 3V$	-40°C to 85°C	-2		2	μA
$I_{OFF(COM)}$	COM Channel-Off Leakage Current	$V_{DD} = 3.6V$, V_{NO} or $V_{NC} = 3V$ & $V_{COM} = 1V$ or V_{NO} or $V_{NC} = 1V$ & $V_{COM} = 3V$	-40°C to 85°C	-2		2	μA
$I_{OFF(NO)}$ or $I_{OFF(NC)}$	NC/NO POWER-Off Leakage Current	$V_{DD} = 0V$, V_{NO} or $V_{NC} = 3.6V$ & $V_{COM} = 0V$ or V_{NO} or $V_{NC} = 0V$ & $V_{COM} = 3.6V$	-40°C to 85°C	-12		12	μA
$I_{OFF(COM)}$	COM POWER-Off Leakage Current	$V_{DD} = 0V$, V_{NO} or $V_{NC} = 3.6V$ & $V_{COM} = 0V$ or V_{NO} or $V_{NC} = 0V$ & $V_{COM} = 3.6V$	-40°C to 85°C	-12		12	μA
$I_{ON(NO)}$ or $I_{ON(NC)}$	Channel-On Leakage Current (NO/NC)	$V_{DD} = 3.6V$, V_{NO} or $V_{NC} = 3V$ & $V_{COM} = open$ or V_{NO} or $V_{NC} = 1V$ & $V_{COM} = open$	-40°C to 85°C	-7		7	μA
$I_{ON(COM)}$	Channel-On Leakage Current (COM)	$V_{DD} = 3.6V$, V_{NO} or $V_{NC} = open$ & $V_{COM} = 3V$ or	-40°C to 85°C	-7		7	μA

Symbol	Parameter	Test Conditions	TEMP	Min.	Typ.	Max.	Units
		V_{NO} or V_{NC} = open & $V_{COM} = 1V$					
DIGITAL INPUTS							
V_{IH}	Input Logic High	-	-40°C to 85°C	0.8	-	3.6	V
V_{IL}	Input Logic Low	-	-40°C to 85°C	0	-	0.2	
I_{IN}	IN Input Leakage Current	$V_{DD} = 3.6V, V_{IN}=0$ or 3.6V	-40°C to 85°C	-2.5	-	2.5	μA
DYNAMIC CHARACTERISTICS							
T_{ON}	Turn-On Time	$V_{DD}=3.3V, V_{COM}=V_{DD}, R_L=50\Omega, C_L=35pF$ <i>See Test Circuit Figure 2.</i>	+25°C	-	11.5	30.0	ns
		$V_{DD}=3V$ to 3.6V, $V_{COM}=V_{DD}, R_L=50\Omega, C_L=35pF$ <i>See Test Circuit Figure 2.</i>	-40°C to 85°C	-	-	30.0	ns
T_{OFF}	Turn-Off Time	$V_{DD}=3.3V, V_{COM}=V_{DD}, R_L=50\Omega, C_L=35pF$ <i>See Test Circuit Figure 2.</i>	+25°C	-	7.6	30.0	ns
		$V_{DD}=3V$ to 3.6V, $V_{COM}=V_{DD}, R_L=50\Omega, C_L=35pF$ <i>See Test Circuit Figure 2.</i>	-40°C to 85°C	-	-	30.0	ns
T_D	Break-Before-Make Delay	$V_{DD}=3.3V, V_{NC}=V_{NO}=V_{DD}, R_L=50\Omega, C_L=35pF$ <i>See Test Circuit Figure 3.</i>	+25°C	4.0	6.5	20.0	ns
		$V_{DD}=3V$ to 3.6V, $V_{NC}=V_{NO}=V_{DD}, R_L=50\Omega, C_L=35pF$ <i>See Test Circuit Figure 3.</i>	-40°C to 85°C	-	-	20.0	ns
f_{3dB}	3dB Bandwidth	$R_L=50\Omega$. <i>See Test Circuit Figure 6.</i>	+25°C	-	380		MHz
O_{ISO}	COM-NC/NO and NC-NO Isolations	$R_L=50\Omega, f=10MHz$ <i>See Test Circuit Figure 4.</i>	+25°C	-	-68		dB
X_{TALKD}	Channel-to-Channel Crosstalk	$R_L=50\Omega, f=10MHz$ <i>See Test Circuit Figure 5.</i>	+25°C	-	-62		dB
$X_{TALK(ADJ)}$	Crosstalk adjacent	$R_L=50\Omega, f=10MHz$ <i>See Test Circuit Figure 5.</i>	+25°C	-	-91		dB
I_{CC}	Power Supply Current	$V_{DD}=3.6V, V_{IN}=0V$ or V_{DD} , Switch ON or OFF	-40°C to 85°C	-		3.0	μA

+1.8V Supply ($V_{DD} = 1.65V$ to $1.95V, T_A = -40^\circ C$ to $85^\circ C$, unless otherwise noted. Typical values are at 1.8V and +25°C.)

Symbol	Parameter	Test Conditions	TEMP	Min.	Typ.	Max.	Units
ANALOG SWITCH							
V_{NO}, V_{NC}, V_{COM}	Analog Signal Range		-40°C to 85°C	0	-	V_{DD}	V
R_{ON}	On-Resistance	$V_{DD} = 1.65V, I_{COM} = -32mA, 0 \leq V_{NO}$ or $V_{NC} \leq V_{DD}$, <i>Test Circuit 1</i>	+25°C	-	7.1	14.4	Ω
			-40°C to 85°C	-	-	16.3	
ΔR_{ON}	On-Resistance Match Between Channels	$V_{DD} = 1.65V, I_{COM} = -32mA, V_{NO}$ or $V_{NC} = 1.5V$, <i>Test Circuit 1</i>	+25°C	-	0.3	1	Ω
			-40°C to 85°C	-	-	1.2	
R_{ONF}	On-Resistance Flatness	$V_{DD} = 1.65V, I_{COM} = -32mA, V_{NO} = 0.15V$ or $V_{NC} = 1.5V$, <i>Test Circuit 1</i>	+25°C	-	2.7	5.5	Ω
			-40°C to 85°C	-	-	7.3	
$I_{OFF(NO)}$ or $I_{OFF(NC)}$	NO/NC Channel-Off Leakage Current	$V_{DD}=1.95V,$ V_{NO} or $V_{NC} = 1.65V$ & $V_{COM} = 0.3V$ or V_{NO} or $V_{NC} = 0.3V$ & $V_{COM} = 1.65V$	-40°C to 85°C	-0.9		0.9	μA
$I_{OFF(COM)}$	COM Channel-Off Leakage Current	$V_{DD}=1.95V,$ V_{NO} or $V_{NC} = 1.65V$ & $V_{COM} = 0.3V$ or V_{NO} or $V_{NC} = 0.3V$ & $V_{COM} =$	-40°C to 85°C	-0.9		0.9	μA

Symbol	Parameter	Test Conditions	TEMP	Min.	Typ.	Max.	Units
		1.65V					
$I_{OFF(NO)}$ or $I_{OFF(NC)}$	NC/NO POWER-Off Leakage Current	$V_{DD}=0V$, V_{NO} or $V_{NC} = 1.95V$ & $V_{COM} = 0V$ or V_{NO} or $V_{NC} = 0V$ & $V_{COM} = 1.95V$	-40°C to 85°C	-5		5	μA
$I_{OFF(COM)}$	COM POWER-Off Leakage Current	$V_{DD}=0V$, V_{NO} or $V_{NC} = 1.95V$ & $V_{COM} = 0V$ or V_{NO} or $V_{NC} = 0V$ & $V_{COM} = 1.95V$	-40°C to 85°C	-5		5	μA
$I_{ON(NO)}$ or $I_{ON(NC)}$	Channel-On Leakage Current (NO/NC)	$V_{DD}=1.95V$, V_{NO} or $V_{NC} = 1.65V$ & $V_{COM} = \text{open}$ or V_{NO} or $V_{NC} = 0.3V$ & $V_{COM} = \text{open}$	-40°C to 85°C	-5.2		5.2	μA
$I_{ON(COM)}$	Channel-On Leakage Current (COM)	$V_{DD}=1.95V$, V_{NO} or $V_{NC} = \text{open}$ & $V_{COM} = 1.65V$ or V_{NO} or $V_{NC} = \text{open}$ & $V_{COM} = 0.3V$	-40°C to 85°C	-5.2		5.2	μA
DIGITAL INPUTS							
V_{IH}	Input Logic High	-	-40°C to 85°C	0.8	-	1.95	V
V_{IL}	Input Logic Low	-	-40°C to 85°C	0	-	0.2	
I_{IN}	IN Input Leakage Current	$V_{DD} = 1.95V$, $V_{IN}=0$ or $1.95V$	-40°C to 85°C	-2.1	-	2.1	μA
DYNAMIC CHARACTERISTICS							
T_{ON}	Turn-On Time	$V_{DD}=1.65V$ to $1.95V$, $V_{COM}=V_{DD}$, $R_L=50\Omega$, $C_L=35pF$ <i>See Test Circuit Figure 2.</i>	+25°C	-	18.9	45	ns
			-40°C to 85°C	-	-	45	
T_{OFF}	Turn-Off Time	$V_{DD}=1.65V$ to $1.95V$, $V_{COM}=V_{DD}$, $R_L=50\Omega$, $C_L=35pF$ <i>See Test Circuit Figure 2.</i>	+25°C	-	14.0	26	ns
			-40°C to 85°C	-	-	26	
T_D	Break-Before-Make Delay	$V_{DD}=1.65V$ to $1.95V$, $V_{COM}=V_{DD}$, $R_L=50\Omega$, $C_L=35pF$ <i>See Test Circuit Figure 3.</i>	+25°C	5.3	11.8	40	ns
			-40°C to 85°C	-	-	40	
f_{3dB}	3dB Bandwidth	$R_L=50\Omega$. <i>See Test Circuit Figure 6.</i>	+25°C	-	380	-	MHz
O_{ISO}	COM-NC/NO and NC-NO Isolations	$R_L=50\Omega$, $f=10MHz$ <i>See Test Circuit Figure 4.</i>	+25°C	-	-66.0	-	dB
X_{TALKD}	Channel-to-Channel Crosstalk	$R_L=50\Omega$, $f=10MHz$ <i>See Test Circuit Figure 5.</i>	+25°C	-	-60.0	-	dB
$X_{TALK(ADJ)}$	Crosstalk adjacent	$R_L=50\Omega$, $f=10MHz$ <i>See Test Circuit Figure 5.</i>	+25°C	-	-91.0	-	dB
I_{CC}	Power Supply Current	$V_{DD}=1.95V$, $V_{IN}=0V$ or V_{DD} , Switch ON or OFF	-40°C to 85°C	-	-	1.5	μA

Capacitance

Symbol	Parameter	Test Conditions	Min.	Typ.	Max.	Units
$C_{NC(OFF)}$, $C_{NO(OFF)}$	NC/NO Off Capacitance	V_{NC} or $V_{NO} = V_{DD}$ or GND, Switch OFF $f = 1MHz$, <i>See Test Circuit Figure 7.</i>	-	10	-	pF
$C_{COM(OFF)}$	COM Off Capacitance	$V_{COM} = V_{DD}$ or GND, Switch OFF $f = 1MHz$, <i>See Test Circuit Figure 7.</i>	-	16	-	
$C_{NC(ON)}$, $C_{NO(ON)}$	NC/NO On Capacitance	V_{NC} or $V_{NO} = V_{DD}$ or GND, Switch ON $f = 1MHz$, <i>See Test Circuit Figure 8.</i>	-	21.5	-	
$C_{COM(ON)}$	COM On Capacitance	$V_{COM} = V_{DD}$ or GND, Switch ON $f = 1MHz$, <i>See Test Circuit Figure 8.</i>	-	21.5	-	
C_{IN}	Digital Input Capacitance	$f = 1MHz$	-	3	-	pF

Test Circuits and Timing Diagrams

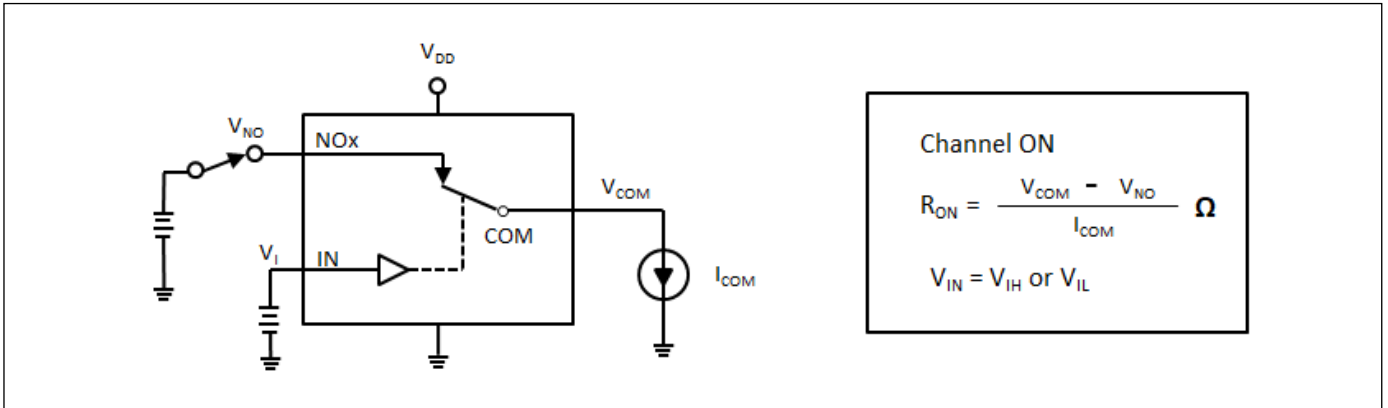

Figure 1. ON Resistance

Notes:

1. Unused input (NC or NO) must be grounded.

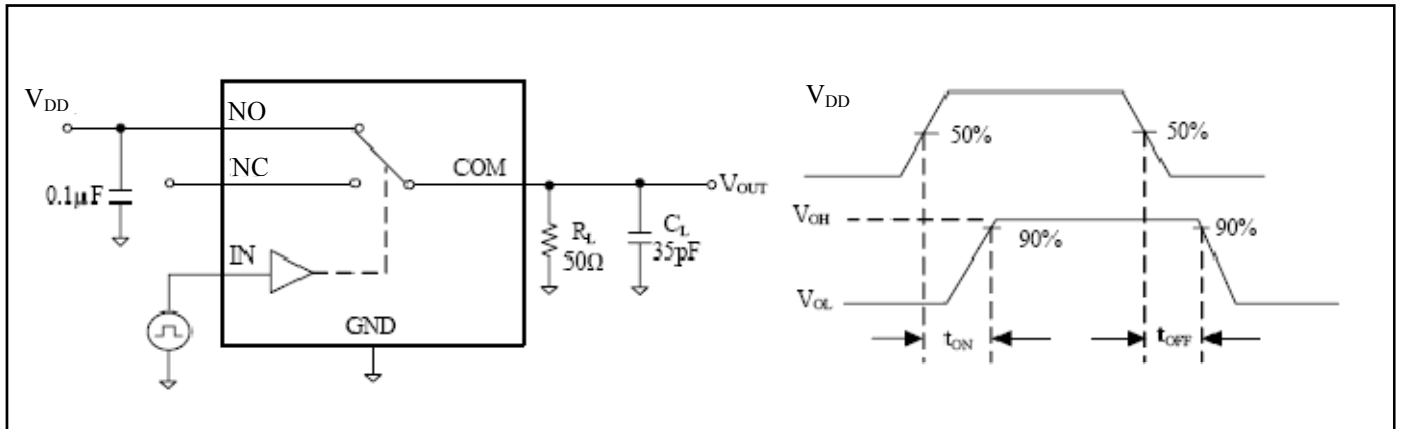

Figure 2. Switching Times

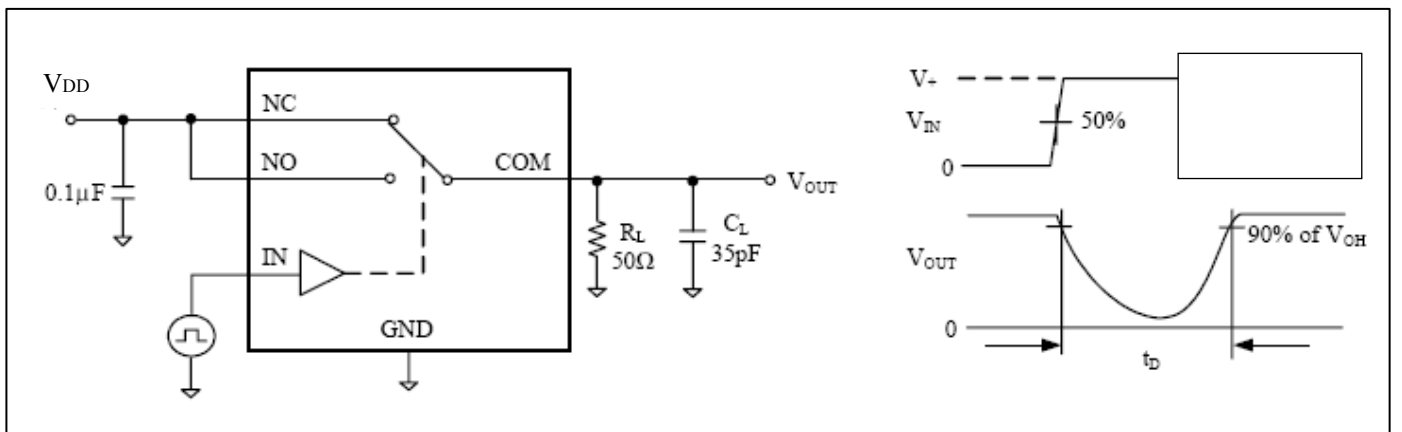

Figure 3. Break Before Make Interval Timing

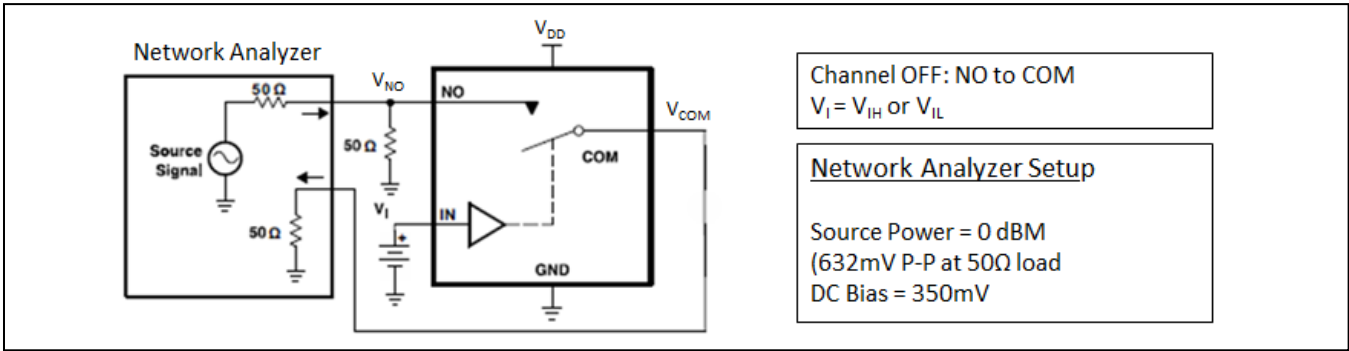

Figure 4. OFF Isolation (O_{ISO})

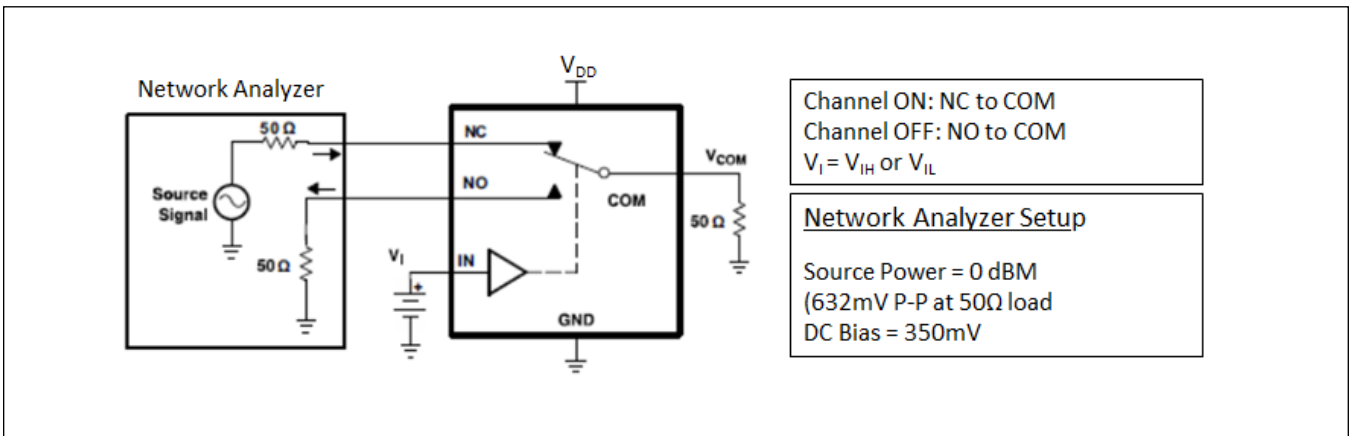

Figure 5. Channel-to-Channel Crosstalk

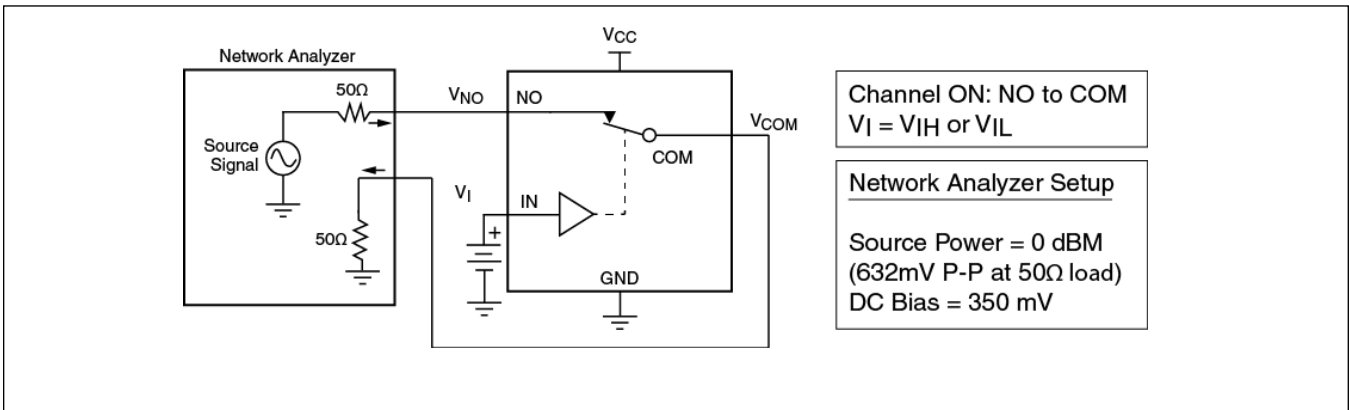

Figure 6. Bandwidth

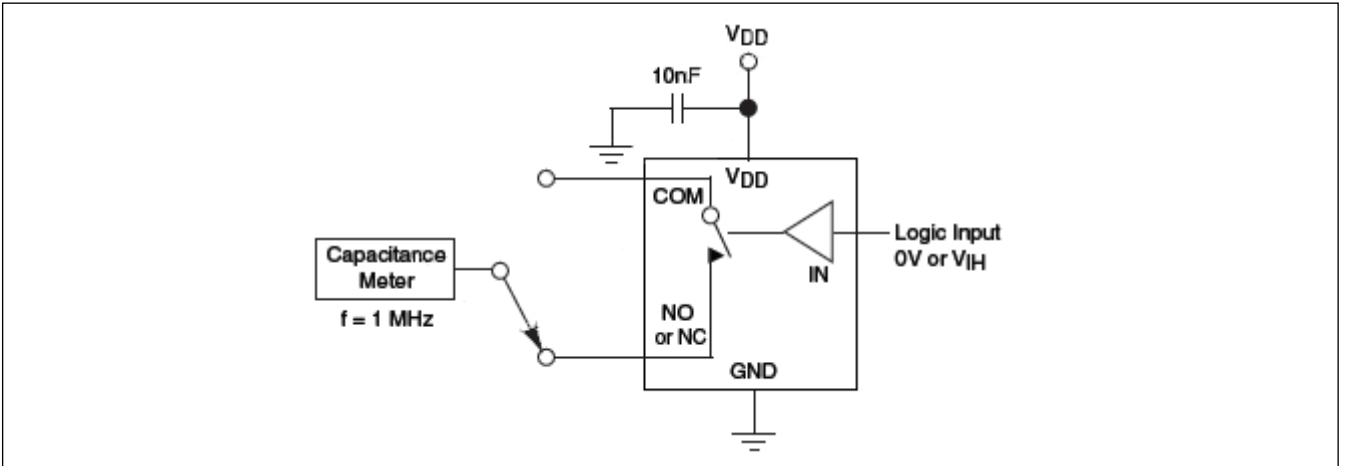

Figure 7. Channel Off Capacitance

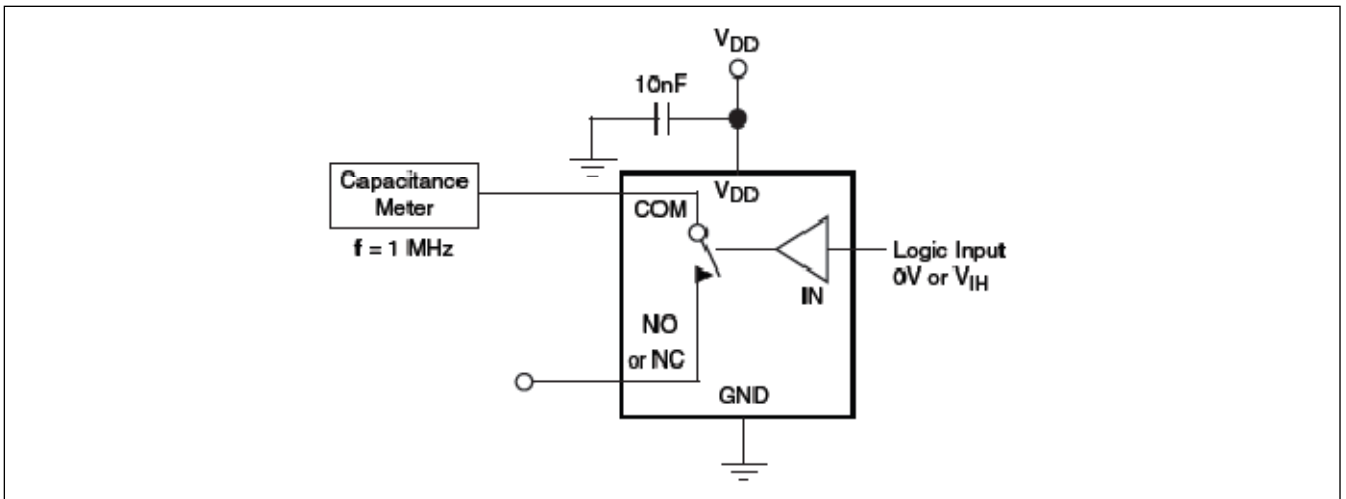
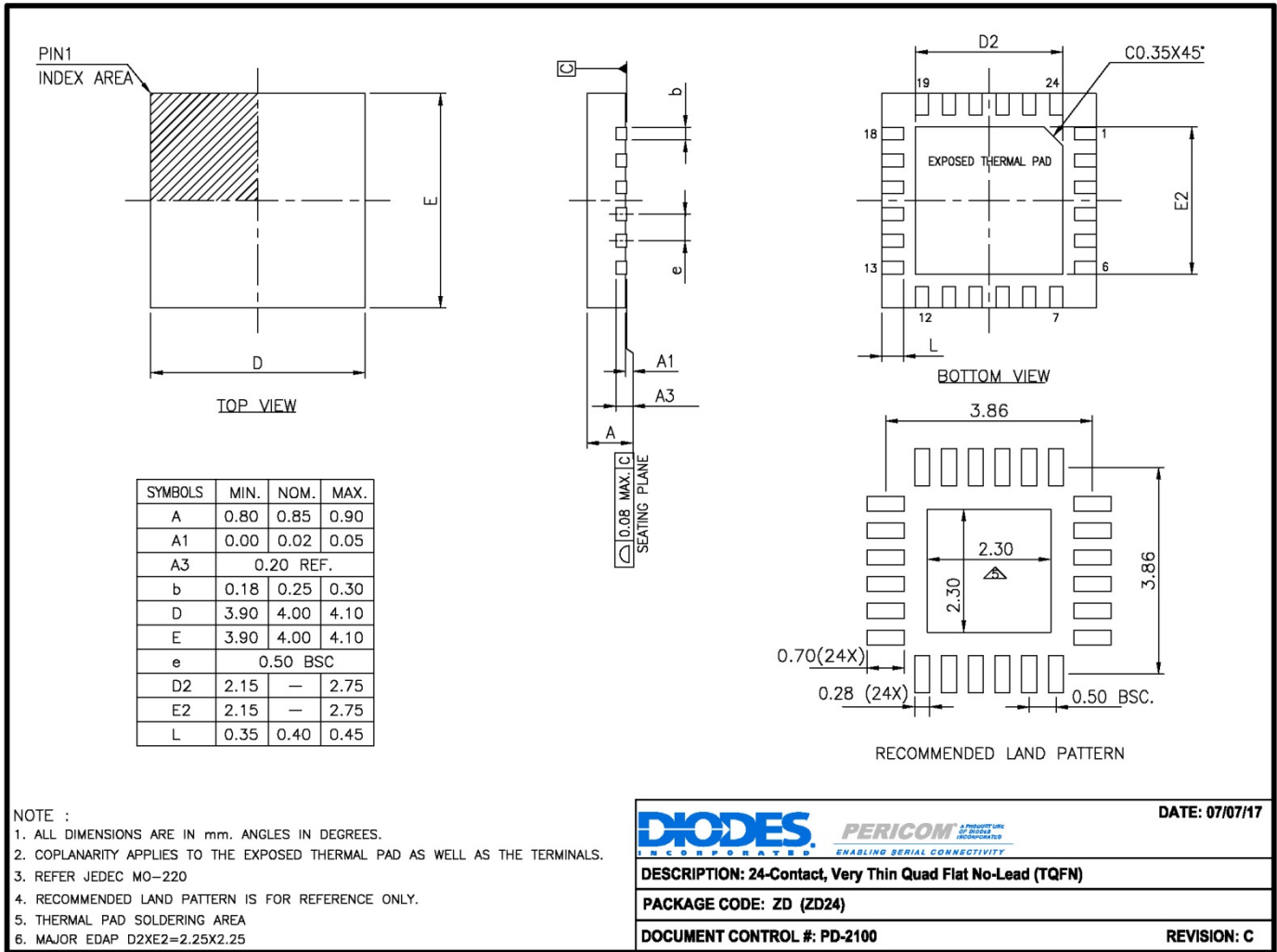

Figure 8. Channel On Capacitance

Part Marking

Top mark not available at this time. To obtain advance information regarding the top mark, please contact your local sales representative.

Packaging Mechanical
24-TQFN (ZD)



17-0533

For latest package info.

please check: <http://www.diodes.com/design/support/packaging/pericom-packaging/packaging-mechanicals-and-thermal-characteristics/>

Ordering Information

Part Number	Packaging Code	Package Description
PI3A27518ZDEX	ZD	24-Contact, Very Thin Quad Flat No-Lead (TQFN)

Notes:

- No purposely added lead. Fully EU Directive 2002/95/EC (RoHS), 2011/65/EU (RoHS 2) & 2015/863/EU (RoHS 3) compliant.
- See <https://www.diodes.com/quality/lead-free/> for more information about Diodes Incorporated's definitions of Halogen- and Antimony-free, "Green" and Lead-free.
- Halogen- and Antimony-free "Green" products are defined as those which contain <900ppm bromine, <900ppm chlorine (<1500ppm total Br + Cl) and <1000ppm antimony compounds.
- E = Pb-free and Green
- X suffix = Tape/Reel

IMPORTANT NOTICE

1. DIODES INCORPORATED AND ITS SUBSIDIARIES (“DIODES”) MAKE NO WARRANTY OF ANY KIND, EXPRESS OR IMPLIED, WITH REGARDS TO ANY INFORMATION CONTAINED IN THIS DOCUMENT, INCLUDING, BUT NOT LIMITED TO, THE IMPLIED WARRANTIES OF MERCHANTABILITY, FITNESS FOR A PARTICULAR PURPOSE OR NON-INFRINGEMENT OF THIRD PARTY INTELLECTUAL PROPERTY RIGHTS (AND THEIR EQUIVALENTS UNDER THE LAWS OF ANY JURISDICTION).
2. The Information contained herein is for informational purpose only and is provided only to illustrate the operation of Diodes products described herein and application examples. Diodes does not assume any liability arising out of the application or use of this document or any product described herein. This document is intended for skilled and technically trained engineering customers and users who design with Diodes products. Diodes products may be used to facilitate safety-related applications; however, in all instances customers and users are responsible for (a) selecting the appropriate Diodes products for their applications, (b) evaluating the suitability of the Diodes products for their intended applications, (c) ensuring their applications, which incorporate Diodes products, comply the applicable legal and regulatory requirements as well as safety and functional-safety related standards, and (d) ensuring they design with appropriate safeguards (including testing, validation, quality control techniques, redundancy, malfunction prevention, and appropriate treatment for aging degradation) to minimize the risks associated with their applications.
3. Diodes assumes no liability for any application-related information, support, assistance or feedback that may be provided by Diodes from time to time. Any customer or user of this document or products described herein will assume all risks and liabilities associated with such use, and will hold Diodes and all companies whose products are represented herein or on Diodes’ websites, harmless against all damages and liabilities.
4. Products described herein may be covered by one or more United States, international or foreign patents and pending patent applications. Product names and markings noted herein may also be covered by one or more United States, international or foreign trademarks and trademark applications. Diodes does not convey any license under any of its intellectual property rights or the rights of any third parties (including third parties whose products and services may be described in this document or on Diodes’ website) under this document.
5. Diodes products are provided subject to Diodes’ Standard Terms and Conditions of Sale (<https://www.diodes.com/about/company/terms-and-conditions/terms-and-conditions-of-sales/>) or other applicable terms. This document does not alter or expand the applicable warranties provided by Diodes. Diodes does not warrant or accept any liability whatsoever in respect of any products purchased through unauthorized sales channel.
6. Diodes products and technology may not be used for or incorporated into any products or systems whose manufacture, use or sale is prohibited under any applicable laws and regulations. Should customers or users use Diodes products in contravention of any applicable laws or regulations, or for any unintended or unauthorized application, customers and users will (a) be solely responsible for any damages, losses or penalties arising in connection therewith or as a result thereof, and (b) indemnify and hold Diodes and its representatives and agents harmless against any and all claims, damages, expenses, and attorney fees arising out of, directly or indirectly, any claim relating to any noncompliance with the applicable laws and regulations, as well as any unintended or unauthorized application.
7. While efforts have been made to ensure the information contained in this document is accurate, complete and current, it may contain technical inaccuracies, omissions and typographical errors. Diodes does not warrant that information contained in this document is error-free and Diodes is under no obligation to update or otherwise correct this information. Notwithstanding the foregoing, Diodes reserves the right to make modifications, enhancements, improvements, corrections or other changes without further notice to this document and any product described herein. This document is written in English but may be translated into multiple languages for reference. Only the English version of this document is the final and determinative format released by Diodes.
8. Any unauthorized copying, modification, distribution, transmission, display or other use of this document (or any portion hereof) is prohibited. Diodes assumes no responsibility for any losses incurred by the customers or users or any third parties arising from any such unauthorized use.

Copyright © 2021 Diodes Incorporated

www.diodes.com

X-ON Electronics

Largest Supplier of Electrical and Electronic Components

Click to view similar products for [Analogue Switch ICs](#) category:

Click to view products by [Diodes Incorporated](#) manufacturer:

Other Similar products are found below :

[FSA3051TMX](#) [NLAS5223BLMNR2G](#) [NLX2G66DMUTCG](#) [425541DB](#) [DG403DY](#) [099044FB](#) [MAX4762ETB+](#) [NLAS3799BMNR2G](#)
[NLAS5123MNR2G](#) [ISL84684IR](#) [PI5A4157CEX](#) [PI5A4599BCEX](#) [NLAS4717EPFCT1G](#) [PI5A3167CCEX](#) [SLAS3158MNR2G](#) [PI5A392AQE](#)
[ADG714BCPZ-REEL7](#) [DG333ALDW-T1-E3](#) [ISL43113IB](#) [ISL43140IB](#) [ISL43140IBZ-T](#) [ISL43143IR](#) [ISL43L120IR](#) [ISL43L121IR](#)
[ISL43L122IR](#) [ISL43L220IR](#) [ISL43L410IR](#) [ISL43L420IR](#) [ISL43L710IR](#) [ISL43L711IR](#) [ISL43L712IR](#) [ISL84053IA](#) [ISL84514IB](#)
[ISL84516IB](#) [ISL84684IUZ-T](#) [LNLASB3157DFT2G](#) [NLAS324US](#) [NLASTV4599DFT2G](#) [ADG842YKSZ-REEL7](#) [WAS4766C-9/TR](#)
[WAS7227Q-10/TR](#) [WAS4646C-36/TR](#) [WAS4735Q-16/TR](#) [BL1532TQFN](#) [RS2233YS16](#) [CH483M](#) [TMUX7236RUMR](#) [ADG836YRMZ-](#)
[REEL](#) [MS3494](#) [ADG412BR-REEL7](#)