

3.3V, Hot Insertion, 8-Bit, 2-Port NanoSwitch™

Features

- Near-Zero propagation delay
- 5-ohm switches connect inputs to outputs
- Fast Switching Speed: 4.5ns (max.)
- Ultra-Low Quiescent Power (0.2µA Typical)
 - Ideally suited for notebook applications
- Packaging (Pb-free & Green):
 - 20-pin 173-mil wide plastic TSSOP (L)

Block Diagram

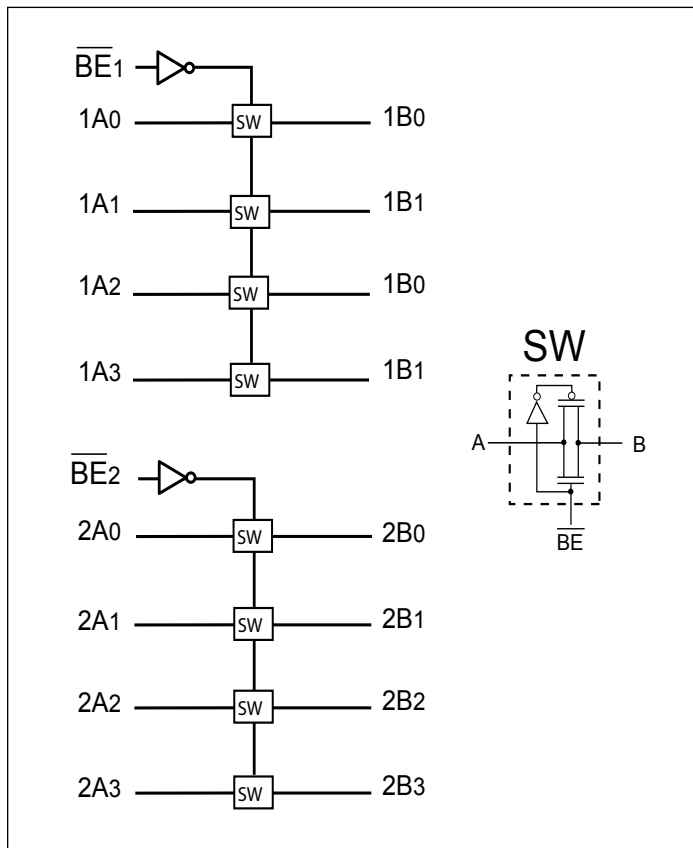

Description

Pericom Semiconductor's PI3B series of logic circuits are produced using the Company's advanced sub-micron CMOS technology, achieving industry leading performance.

The PI3B3244 features a set of 3.3V 8-bit bus switches, which is pinout and function compatible with the P74FCT244T, 74F244, and 74ALS/AS/LS2448-bit drivers. Two enable signals ($\overline{BE}n$) turn the switches on similar to the enable signals of the 244. The bus switch create no additional propagation delay or ground bounce noise.

Pin Configuration

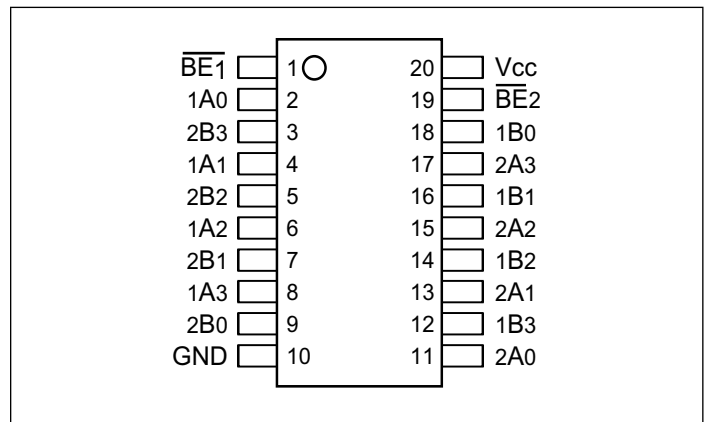

Pin Description

Pin Name	Description
$\overline{BE}n$	Bus Enable Input (Active LOW)
A0-7	Bus A
B0-7	Bus B
GND	Ground
V _{CC}	Power

Truth Table⁽¹⁾

$\overline{BE}1$	$\overline{BE}2$	1A, 1B	2A, 2B
H	H	Disconnect	Disconnect
L	H	1A = 1B	Disconnect
H	L	Disconnect	2A = 2B
L	L	1A = 1B	2A = 2B

Note:

1. H = High Voltage Level, L = Low Voltage Level

Absolute Maximum Ratings

Parameter	Min.	Max.	Units
Storage Temperature	-65	150	°C
Ambient Temperature with Power Applied	-40	85	°C
Supply Voltage to Ground Potential	-0.5	4.6	V
DC Input Voltage	-0.5	4.6	V
DC Output Current	-	120	mA
Power Dissipation	-	0.5	W

Stress beyond those listed under “Absolute Maximum Ratings” may cause permanent damage to the device.

DC Electrical Characteristics (Over the Operating Range, $T_A = -40^{\circ}\text{C}$ to $+85^{\circ}\text{C}$, $V_{CC} = 3.3\text{V} \pm 10\%$)

Parameters	Description	Test Conditions ⁽¹⁾	Min	Typ ⁽²⁾	Max	Units
V_{IH}	Input HIGH Voltage	Guaranteed Logic HIGH Level	2.0			V
V_{IL}	Input LOW Voltage	Guaranteed Logic LOW Level	-0.5		0.8	V
I_{IH}	Input HIGH Current	$V_{CC} = \text{Max.}, V_{IN} = V_{CC}$			± 1	μA
I_{IL}	Input LOW Current	$V_{CC} = \text{Max.}, V_{IN} = \text{GND}$			± 1	μA
I_{OZH}	High Impedance Output Current	$0 \leq I_N, Y_N \leq V_{CC}$			± 1	μA
V_{IK}	Clamp Diode Voltage	$V_{CC} = \text{Min.}, I_{IN} = -18 \text{ mA}$			-1.2	V
R_{ON}	Switch On Resistance ⁽³⁾	$V_{CC} = \text{Min.}, V_{IN} = 0.0\text{V}, I_{ON} = 48\text{mA}$ or 64mA		5	8	Ω
		$V_{CC} = \text{Min.}, V_{IN} = 2.4\text{V}, I_{ON} = 15\text{mA}$		10	17	

Capacitance ($T_A = 25^{\circ}\text{C}$, $f = 1 \text{ MHz}$)

Parameters ⁽¹⁾	Description	Test Conditions	Typ	Units
C_{IN}	Input Capacitance	$V_{IN} = 0\text{V}$	3.0	pF
C_{OFF}	A/B Capacitance, Switch Off	$V_{IN} = 0\text{V}$	8.0	pF
C_{ON}	A/B Capacitance, Switch On	$V_{IN} = 0\text{V}$	16.0	pF

Notes:

- For Max. or Min. conditions, use appropriate value specified under Electrical Characteristics for the applicable device type.
- Typical values are at $V_{CC} = 3.3\text{V}$, $T_A = 25^{\circ}\text{C}$ ambient and maximum loading.
- Measured by the voltage drop between A and B pin at indicated current through the switch. ON resistance is determined by the lower of the voltages on the two (A,B) pins.
- This parameter is determined by device characterization but is not production tested.

Power Supply Characteristics

Parameters	Description	Test Conditions ⁽¹⁾		Min	Typ ⁽²⁾	Max	Units
I _{CC}	Quiescent Power Supply Current	V _{CC} = Max.	V _{IN} = GND or V _{CC}		0.1	3.0	μA
ΔI _{CC}	Supply Current per Input @ TTL HIGH	V _{CC} = Max.	V _{IN} = 3.0V ⁽³⁾			750	μA

Notes:

1. For Max. or Min. conditions, use appropriate value specified under Electrical Characteristics for the applicable device.
2. Typical values are at V_{CC} = 3.3V, +25°C ambient.
3. Per TTL driven input (control input only); A and B pins do not contribute to I_{CC}.

Switching Characteristics over Operating Range

Parameters	Description	Test Conditions ⁽¹⁾	Com.		Units
			Min	Max	
t _{PLH} t _{PHL}	Propagation Delay ^(2,3) Ax to Bx	CL = 50 pF RL = 500Ω		0.25	ns
t _{PZH} t _{PZL}	Bus Enable Time $\overline{\text{BE}}$ to Ax or Bx		1.0	4.0	
t _{PHZ} t _{PLZ}	Bus Disable Time $\overline{\text{BE}}$ to Ax or Bx		1.0	4.5	

Notes:

1. See test circuit and wave forms.
2. This parameter is guaranteed but not tested on Propagation Delays.
3. The bus switch contributes no propagational delay other than the RC delay of the On-Resistance of the switch and the load capacitance. The time constant for the switch alone is of the order of 0.25 ns for 50 pF load. Since this time constant is much smaller than the rise/fall times of typical driving signals, it adds very little propagational delay to the system. Propagational delay of the bus switch when used in a system is determined by the driving circuit on the driving side of the switch and its interaction with the load on the driven side.

Applications Information

Logic Inputs

The logic control inputs can be driven up to +3.6V regardless of the supply voltage. For example, given a + 3.3V supply, IN may be driven low to 0V and high to 3.6V. Driving IN Rail-to-Rail® minimizes power consumption.

Power-Supply Sequencing and Hot-Plug Information

Proper power-supply sequencing is recommended for all CMOS devices. Always apply V_{CC} and GND before applying signals to input/output or control pins.

Rail-to-Rail is a registered trademark of Nippon Motorola, Ltd.

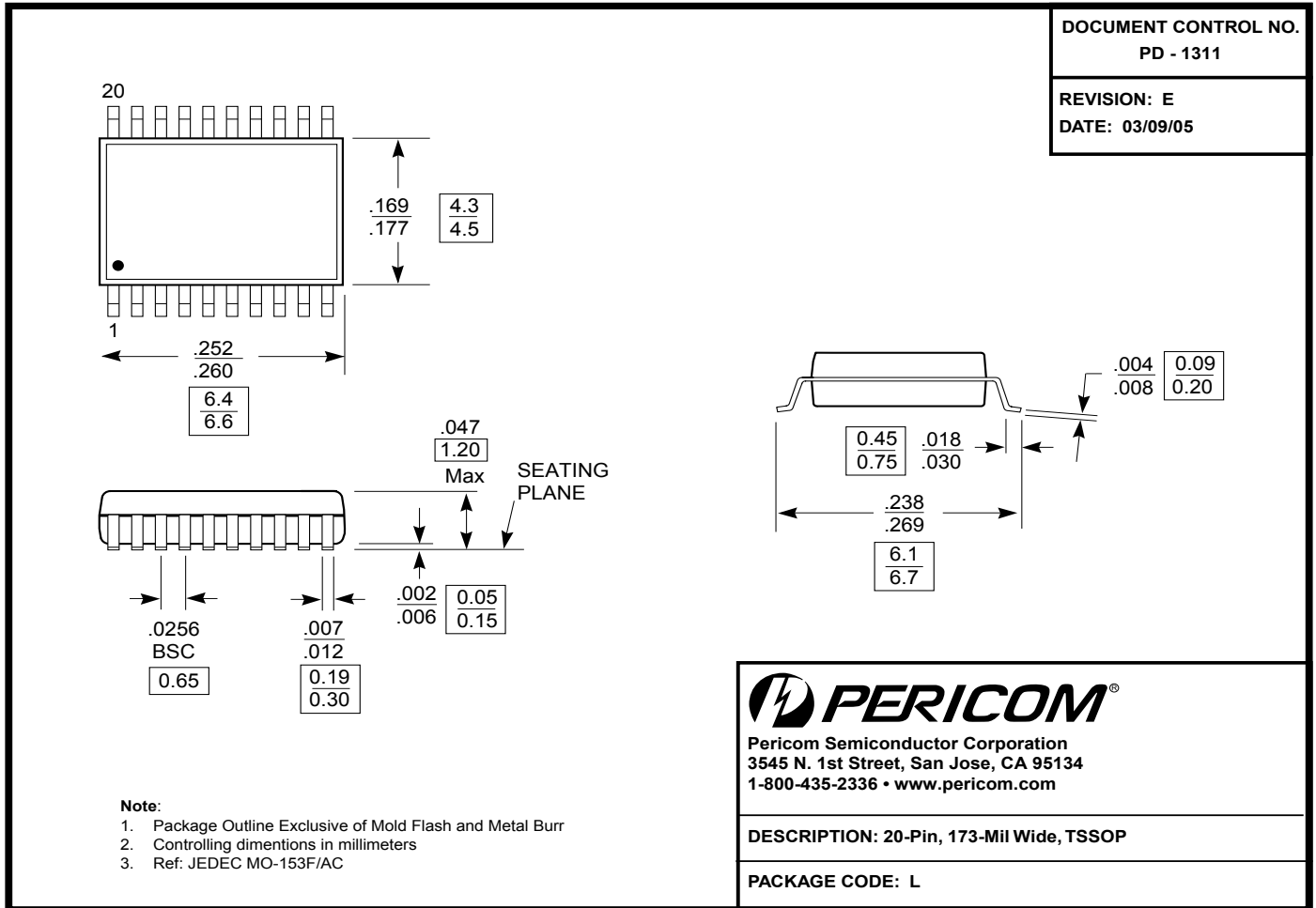
Packaging Mechanical: 20-Pin TSSOP (L)

Ordering Information

Ordering Code	Package Code	Package Type
PI3B3244LE	L	Pb-free & Green, 20-pin TSSOP

 1. Thermal characteristics can be found on the company web site at www.pericom.com/packaging/

X-ON Electronics

Largest Supplier of Electrical and Electronic Components

Click to view similar products for [Digital Bus Switch ICs](#) category:

Click to view products by [Diodes Incorporated](#) manufacturer:

Other Similar products are found below :

[MT8986AE1](#) [TC7MPB9307FT\(EL\)](#) [MT8985AE1](#) [MT8986AP1](#) [ZL50012QCG1](#) [PI3CH800LE](#) [PI3C32X384BE](#) [ZL50023GAG2](#)
[MT8986AL1](#) [MT8981DP1](#) [PI3VT3245-ALE](#) [PI3CH800QE](#) [MT90823AB1](#) [PI5C3125QEX](#) [PI3VT3245-AQE](#) [PI3CH800QEX](#) [PI3C3384QE](#)
[PI3C3305UEX](#) [PI3B3861QE](#) [PI3B3245QEX](#) [PI3B3245QE](#) [PI3CH800ZHEX](#) [PI3CH1000LE](#) [PI3CH400ZBEX](#) [PI3CH401LE](#) [PI3CH401LEX](#)
[TC7WBL3305CFK\(5L,F](#) [74CB3Q3125DBQRE4](#) [TC7WBL3305CFK,LF](#) [SN74CBT16245CDGGR](#) [72V90823PQFG](#) [PI3B3861QEX](#)
[PI3C3245QE](#) [PI5C3384QE](#) [PI3CH281QE](#) [PI3C3306LE](#) [PI3C3305LE](#) [PI5C3245LE](#) [PI3CH400LE](#) [PI3B3245LEX](#) [PI3B3245LE](#)
[PI3C3306LEX](#) [PI5C3245LEX](#) [PI3B3126LE](#) [PI3B3126LEX](#) [74CBTLV3862PGG](#) [QS3VH126QG](#) [QS3VH16861PAG](#) [QS3VH126S1G](#)
[QS3L384QG](#)