

## PI3EQX6801

### 6.5Gbps, 1-port, 1.5V/3.3V SATA/SAS ReDriver™ with Analog/Digital Configuration

Pericom Semiconductor's PI3EQX6801 is a low power, 1.5V/3.3V, 6.5Gbps, SATA/SAS signal ReDriver™. The device provides programmable equalization, to optimize performance over a variety of physical mediums by reducing Inter-Symbol Interference.

PI3EQX6801 supports two 100Ω Differential CML data I/O's between the Protocol ASIC to a switch fabric, across a backplane, or to extend the signals across other distant data pathways on the user's platform.

The integrated equalization circuitry provides flexibility with signal integrity of the signal before the ReDriver.

A low-level input signal detection and output squelch function is provided for each channel. Each channel operates fully independently. When the channels are enabled ( $x\_EN\# = 0$ ) and operating, that channels input signal level (on  $xI+/-$ ) determines whether the output is active. If the input signal level of the channel falls below the active threshold level ( $V_{th-}$ ) then the outputs are driven to the common mode voltage.

Each lane can be powered-down if  $x\_EN\# = 1$ , and when  $A\_EN\#$  and  $B\_EN\#$  are both high, the device enters a low power standby mode.

#### Applications

- Server
- Desktop
- Data Storage/Workstation

#### Block Diagram

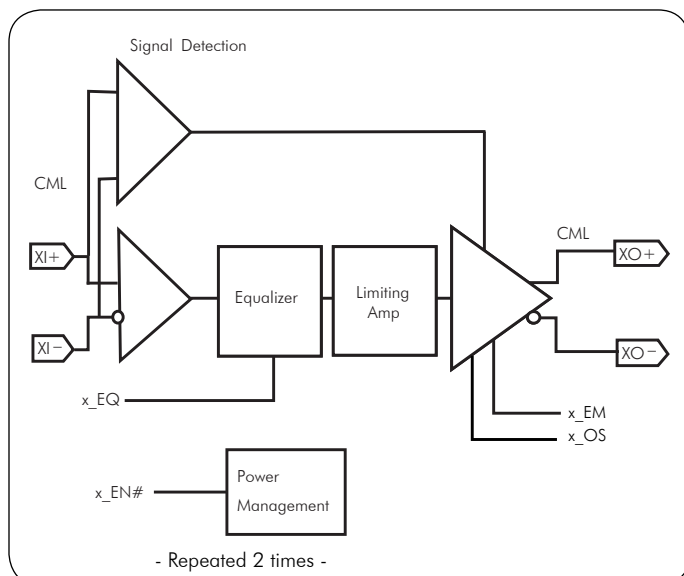

#### Features

- Two 6.5Gbps differential channels
- Output swing up to 1.2V pk-to-pk
- SAS, SATA fully supported
- Adjustable Receiver Equalization - 0 to 16 dB
- 100Ω Differential CML I/O's
- Continuous step output swing adjustment
- Continuous step output pre-emphasis control
- Input signal level detect and squelch for each channel
- OOB fully supported
- Auto HDD Rate Detection for out swing/emphasis setting
- Supply Voltage: 1.5V or 3.3V
- Low Power, 162mW @ 1.5V (600 mV Swing)
- Stand-by Mode – Power Down State: Current < 56 μA
- HDD unplug power: 1.5mW
- Auto Slumber Mode power: 22.5mW typical
- Industrial Temperature Range -40 to 85°C
- Packaging: 20-contact TQFN (4x4mm)

#### ReDriver in Storage Array Application

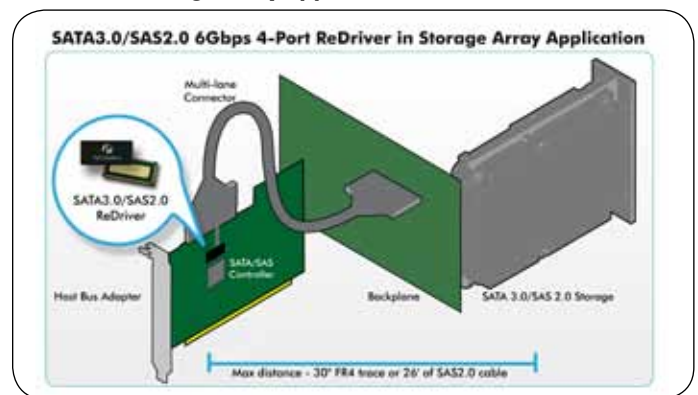

**Figure 1**

Redrivers with emphasis and equalization signal conditioning technology ensure the integrity of high-frequency SAS2.0/SATA3.0 signals by opening closed signal eyes to recover data and meet strict compliance testing requirements. Increased signal margin also supports longer drive lengths over even low-quality cables

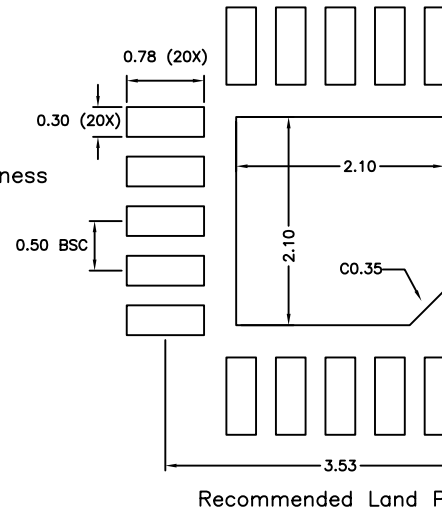
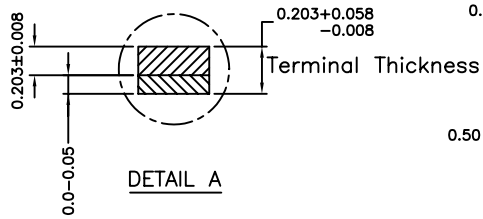
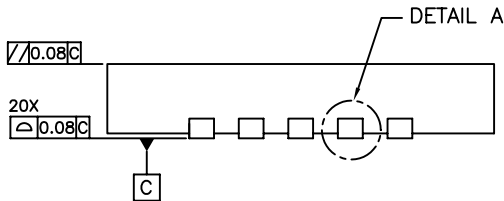
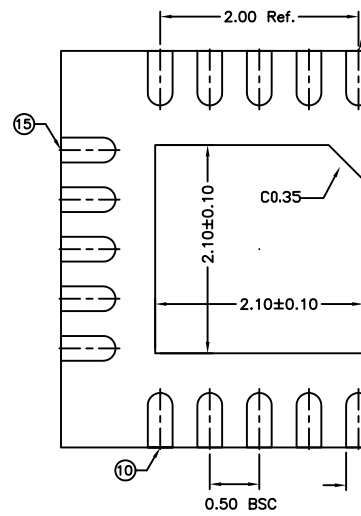
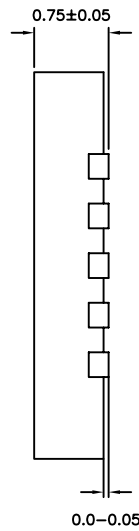
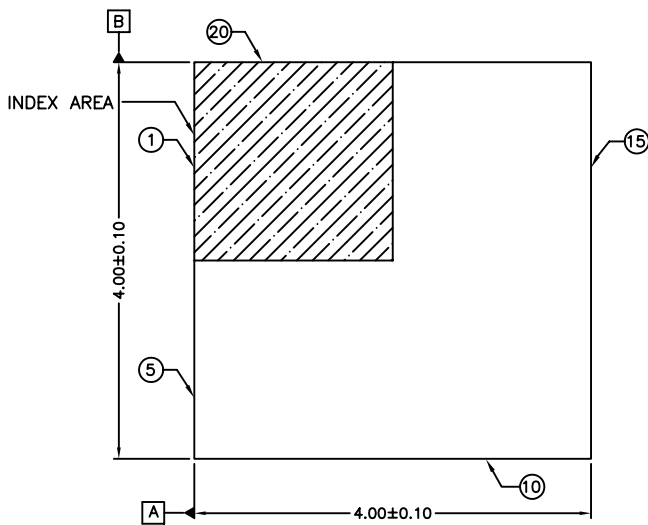

NOTE :

1. ALL DIMENSIONS ARE IN mm. ANGLES IN DEGREES.
2. COPLANARITY APPLIES TO THE EXPOSED PAD AS WELL AS THE TERMINALS. COPLANARITY SHALL NOT EXCEED 0.08 mm.
3. WARPAGE SHALL NOT EXCEED 0.08 mm.
4. REFER JEDEC MO-220.



DESCRIPTION: 20-Lead, Thin Fine Pitch Quad F

PACKAGE CODE: ZD20

DOCUMENT CONTROL #: PD-2084

# Material Declaration Report

Package Type:	TQFN 20L
Pericom Package Code:	ZD20(Pb-free)
RoHS Compliance:	Yes
Applicable Exemption:	N/A

Component Weight (mg):	37.4932
Termination Plating:	NiPdAu
JESD 97 Pb-free Category:	e4
Plating Thickness (um):	0.5~2.2
Tin Whisker Mitigation:	N/A

MSL Rating:	1
Peak Body Temp (C):	260
Max Time (sec):	30
Reflow Cycles:	3
Rev Date:	4/17/2009

## Homogeneous Material Declaration

MATERIAL ITEM	MATERIAL WEIGHT(mg)	ASSEMBLY SUBCON	MATERIAL COMPOSITION	CAS NO.	COMPOSITION %	COMPOSITION WEIGHT(mg)
MOLD COMPOUND	18.5338	UTL	Silica fuse	60676-86-0	90.500	16.77304
			Epoxy resin	Proprietary	4.500	0.83402
			Phenol resin	Proprietary	4.500	0.83402
			Carbon black	1333-86-4	0.500	0.09267
LEADFRAME	17.3380		Copper	7440-50-8	96.953	16.80976
			Iron	7439-89-6	2.350	0.40744
			Zinc	7440-66-6	0.111	0.01921
			Phosphorus	7723-14-0	0.065	0.01127
			Nickel	7440-02-0	0.473	0.08196
			Palladium	7440-05-3	0.041	0.00711
			Gold	7440-57-5	0.007	0.00128
SILICON DIE	0.8857		Silicon (Si)	7440-21-3	99.192	0.87856
			Non-hazardous Metal	Proprietary	0.808	0.00716
DIE ATTACH EPOXY	0.2500		Silver	7440-22-4	80.000	0.20000
			Acrylate Resin	Proprietary	16.000	0.04000
			Heterocyclic organic compound	Proprietary	2.000	0.00500
			Treated Silica	7631-86-9	2.000	0.00500
GOLD WIRE	0.4857		Gold(Au)	7440-57-5	99.990	0.48567
			Impurities	-	0.010	0.00005

NOTE: The device contents disclosed are approximated and are based on engineering estimates.

## 3rd Party Analysis Results (PPM)

MATERIAL	Pb	Hg	Cr+6	Cd	PBB	PBDE
Mold Compound	<2	<2	<2	<2	<5	<5
Leadframe	<50	<2	<2	<2	<5	<5
Silicon Die	<2	<2	<2	<2	<5	<5
Die Attach Epoxy	<2	<2	<2	<2	<5	<5
Gold Wire	<2	<2	<2	<2	<5	<5
Solder Plating	<2	<2	<2	<2	<5	<5

## ROHS MATERIAL COMPOSITION DECLARATION

EU RoHS Directive 2002/95/EC  and  China RoHS Directive SJ/T11363-2006	<b>Declaration Statement:</b>	Quantity limit of 0.1% (1000 PPM) by mass in homogeneous material for: Lead (Pb), Mercury, Hexavalent Chromium(Cr+6), Polybrominated Biphenyls (PBB), Polybrominated Diphenyl Ethers (PBDE); and Quantity limit of 0.01% (100 PPM) for Cadmium					
		Pb	Hg	Cr+6	Cd	PBB	PBDE
	<1000ppm	<1000ppm	<1000ppm	<100ppm	<1000ppm	<1000ppm	
	O	O	O	O	O	O	

O: Indicates that this toxic or hazardous substance contained in all of the homogeneous materials for this part is below the limit requirement in SJ/T11363-2006.  
X: Indicates that this toxic or hazardous substance contained in at least one of the homogeneous materials used for this part is above the limit requirement in SJ/T11363-2006.

**Qualification Description:**

The information contained herein represents proof of Reliability and Performance of the Package Series listed below in accordance with the Qualification Plan and test methods referenced in Section 7.0, after exposure to a variety of environments and mechanical events that occur during installation and operational lifetime of the product. Upon conclusion of the testing the product continued to operate within specification limits, demonstrating its capability of reliable operation throughout its lifetime.

The purpose of this report is to present Qualification Test results of the referenced Package Series. The Pericom product data presented in this report qualifies the products manufactured in this package configuration, using the same bill of materials and assembled by the identified subcontractor location. The report describes the qualification test program, procedures utilized, criteria enforced (at the time of product validation), and specific result data obtained during the testing of three lots of semiconductors. The three lots consist of an equal number of units from different date codes, from the same production line and SubContractor to ensure manufacturing repeatability.

**Lot Background Information:**

Qual Vehicle:	PI2EQX3201BZFE	Qual Test Date:	May-2009 update Jan-2012
Supplier (Code):	GTK (G)	Die Attach Material:	Ablebond 8200T
Pkg Type - Code:	TQFN-36 (ZF36)	Wire Size & Material:	1.0 mil Gold
Outline Drawing:	PD-223	Mold Compound:	EME G700HA
By Extension Pkg:	ZD20	Leadframe Material:	Copper
		Lead Finish:	PPF

Date Codes: X0913GU X0914GU X0915GU

**Pericom's Qualification Test Results:**

Stress Test	Test Procedure	Test Conditions	Duration	# of Lots	Samples per Lot	Results Pass/Fail
Preconditioning	JESD22-A113	MSL1	NA	3	100	100 / 0
CSAM	J-STD-020	No delamination of Die Top, Wire bond, Down bond areas	NA	3	22	22 / 0
PreCon UHAST	JESD22-A118	130°C, RH 85%, 33.3 psia, 0V	96 hrs	3	50	50 / 0
PreCon Temp Cycle	JESD22-A104	-65°C to +150°C 500 Cycles	100 cycles	3	50	50 / 0
		-65°C to +150°C 500 Cycles	500 cycles	3	50	50 / 0
Physical Dimension	JESD22-B100	Per Datasheet	NA	3	5	5 / 0
External Visual Insp	JESD22-B101	NA	NA	3	5	5 / 0
Solderability	J-STD-020 JESD22-B102	Pb-Free Solder Dip 245°C	NA	3	5	5 / 0

**Qualification by Extension Information:**

Where a product of interest is not sampled during this period, it is valid to use the reliability data of the particular process technology or package type family to which the part belongs. All parts within the same family are designed to the same rules, and manufacturing is controlled by SPC. Within a product family, a device can only be fabricated on one process technology/ option, and only assembled on one package type process.

If there are any questions about this qualification, please contact Quality Support at: [customerquestion@pericom.com](mailto:customerquestion@pericom.com)

Date: May-2009 update Jan-2012  
 PKG Type & Code: TQFN-36 (ZF36)  
 Assembler-Code: GTK (G)  
 Qual Device: PI2EQX3201BZFE

**By extension: Pericom active devices using the Fab/Process at the time of the Qualification:**

PI2EQX3201BLZFE	PI3EQX6801ZDE		
PI2EQX3201BLZFEX	PI3EQX6801ZDEX		
PI2EQX3201BZFE	PI3EQX6852BZDE		
PI2EQX3201BZFEX	PI3EQX6852BZDEX		
PI2EQX4401DZFE	PI3EQX7701ZDE		
PI2EQX4401DZFEX	PI3EQX7701ZDEX		
PI2EQX4401ZFE	PI3EQX7711ZDE		
PI2EQX4401ZFEX	PI3EQX7711ZDEX		
PI2EQX4951SLAZDE	PI3EQX7741IZDE		
PI2EQX4951SLAZDEX	PI3EQX7741IZDEX		
PI2EQX4951SLZDE	PI3EQX7741STZDE		
PI2EQX4951SLZDEX	PI3EQX7741STZDEX		
PI2EQX6741SLZDE	PI4ULS3V08ZFEX		
PI2EQX6741SLZDEX	PI4ULS3V08ZFEX		
PI2EQX6811ZDE	PI6PCIEB24ZDE		
PI2EQX6811ZDEX	PI6PCIEB24ZDEX		
PI2EQXDP101-AZFE			
PI2EQXDP101-AZFEX			
PI2EQXDP101ZFE			
PI2EQXDP101ZFEX			
PI3EQX3251BLZFE			
PI3EQX3251BLZFEX			
PI3EQX4951BZDE			
PI3EQX4951BZDEX			
PI3EQX4951STAZDE			
PI3EQX4951STAZDEX			
PI3EQX4951STZDE			
PI3EQX4951STZDEX			
PI3EQX5701ZDE			
PI3EQX5701ZDEX			
PI3EQX6701AZDE			
PI3EQX6701AZDEX			
PI3EQX6701CZDE			
PI3EQX6701CZDEX			
PI3EQX6701DZDE			
PI3EQX6701DZDEX			
PI3EQX6701EZDE			
PI3EQX6701EZDEX			
PI3EQX6701ZDE			
PI3EQX6701ZDEX			
PI3EQX6741STBZDE			
PI3EQX6741STBZDEX			
PI3EQX6741STZDE			
PI3EQX6741STZDEX			

## X-ON Electronics

Largest Supplier of Electrical and Electronic Components

*Click to view similar products for* [Interface - Signal Buffers, Repeaters](#) *category:*

*Click to view products by* [Diodes Incorporated](#) *manufacturer:*

Other Similar products are found below :

[PI6ULS5V9509UEX](#) [PI3HDMI101-BZHEX](#) [PI3EQX12904AZHEX](#) [PI6ULS5V9306WEX](#) [PI3EQX1004EZTFEX](#) [PI6ULS5V9509WEX](#)  
[48705-3001R2](#) [48705-6501R2](#) [DS280BR820ZBLT](#) [PCA9617ADPJ](#) [PI6ULS5V9515AWEX](#) [PI3HDMI101ZHE](#) [LTC4315CDE#PBF](#)  
[LTC4300-1CMS8#PBF](#) [DS110DF1610FB/NOPB](#) [LTC4301LCDD#PBF](#) [LTC4303IDD#PBF](#) [LTC4315IMS#TRPBF](#) [LTC4304IMS#PBF](#)  
[DS280DF810ABVT](#) [LTC4315IDE#PBF](#) [LTC4300-1IMS8#PBF](#) [LTC4313IMS8-3#TRPBF](#) [LTC4300-2IMS8#PBF](#) [LTC4300A-1CMS8#PBF](#)  
[PCA9515AD,118](#) [LTC4307CMS8-1#TRPBF](#) [LTC4304CDD#PBF](#) [PI3EQX1002B1ZLEX](#) [LTC4301LIMS8](#) [LTC4313IDD-3#TRPBF](#)  
[LTC4309IGN#PBF](#) [LTC4309CGN#PBF](#) [MAX9169EUE+](#) [LTC4302IMS-2#PBF](#) [LTC4302CMS-1#PBF](#) [PI6ULS5V9306UEX](#) [LTC4300A-](#)  
[1CMS8#TRPBF](#) [P82B715TD,112](#) [PCA9507DP,118](#) [PCA9509DP,118](#) [PCA9509GM,125](#) [PCA9515ADP,118](#) [PCA9517AD,118](#)  
[PCA9517ADP,118](#) [PCA9517DP,118](#) [P82B715TD,118](#) [PI6ULS5V9511AWEX](#) [PI1EQX512AXUAEX](#) [PI2EQX502TZHEX](#)