

3.3V, Wide Bandwidth, Quad 2:1 Mux/DeMux LAN Switch

Features

- Replaces Mechanical Relays
- High-performance, Low-cost solution for switching between different LAN Signals
- Ultra-low Quiescent Power (0.1µA typical)
- Low Crosstalk: -100dB @ 10 MHz
- Low Insertion Loss or On-Resistance (5Ω typical)
- Single Supply Operation: 3.3V ±10%
- Off Isolation: -50dB @ 10 MHz
- Wide-bandwidth data rates: >200 MHz
- Packaging (Pb-free & Green available):
 - 16-pin 150 mil wide plastic QSOP (Q)

Description

Pericom Semiconductor’s PI3L100 is a Quad 2:1 multiplexer/demultiplexer LanSwitch with three-state outputs. This device can be used for switching between various standards, such as 10 Base-T and 100 Base-T. Generally, this part can be used to replace mechanical relays in low voltage LAN applications that have physical layer, unshielded twisted pair media (UTP) with either CAT 3 or CAT 5 grade cable.

Block Diagram

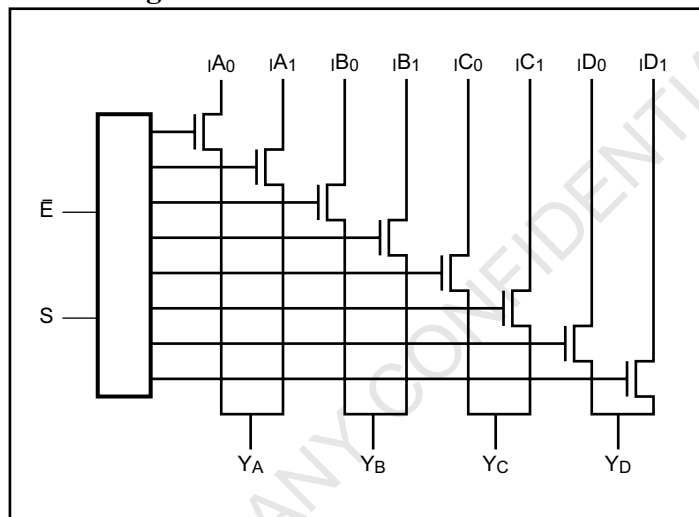

Pin Configuration

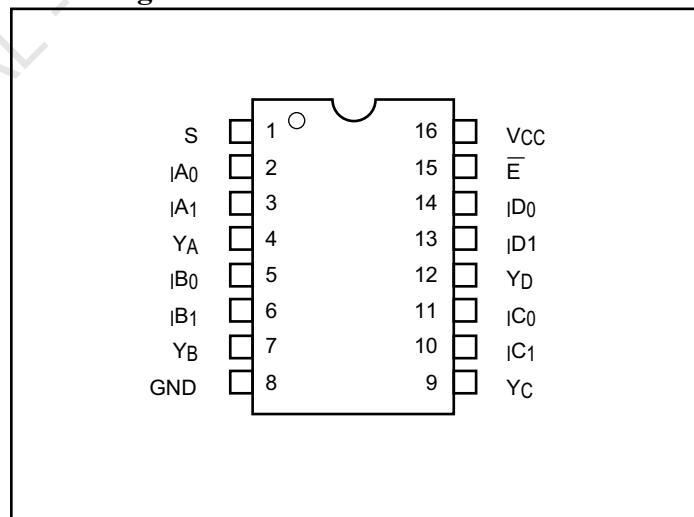

Truth Table⁽¹⁾

\bar{E}	S	YA	YB	YC	YD	Function
H	X	Hi-Z	Hi-Z	Hi-Z	Hi-Z	Disable
L	L	I_{A0}	I_{B0}	I_{C0}	I_{D0}	S = 0
L	H	I_{A1}	I_{B1}	I_{C1}	I_{D1}	S = 1

Note:

1. H = High Voltage Level, L = Low Voltage Level, X = Don't Care

Pin Description

Pin Name	Description
I_{An-IDn}	Data Inputs
S	Select Inputs
\bar{E}	Enable
YA-YD	Data Outputs
GND	Ground
VCC	Power

Maximum Ratings

(Above which the useful life may be impaired. For user guidelines, not tested.)

Storage Temperature	-65°C to +150°C
Ambient Temperature with Power Applied	0°C to +70°C
Supply Voltage to Ground Potential (Inputs & V _{CC} Only) ...	-0.5V to +4.6V
Supply Voltage to Ground Potential (Outputs & D/O Only)	-0.5V to +4.6V
DC Input Voltage	-0.5V to +4.6V
DC Output Current.....	120 mA
Power Dissipation	0.5W

Note:

Stresses greater than those listed under MAXIMUM RATINGS may cause permanent damage to the device. This is a stress rating only and functional operation of the device at these or any other conditions above those indicated in the operational sections of this specification is not implied. Exposure to absolute maximum rating conditions for extended periods may affect reliability.

DC Electrical Characteristics (Over the Operating Range, T_A = -40°C to +85°C, V_{CC} = 3.3V ±5%)

Parameters	Description	Test Conditions ⁽¹⁾	Min.	Typ. ⁽²⁾	Max.	Units
V _{IH}	Input HIGH Voltage	Guaranteed Logic HIGH Level	2.0			V
V _{IL}	Input LOW Voltage	Guaranteed Logic LOW Level	-0.5		0.8	
I _{IH}	Input HIGH Current	V _{CC} = Max., V _{IN} = V _{CC}			±1	μA
I _{IL}	Input LOW Current	V _{CC} = Max., V _{IN} = GND			±1	
I _{OZ}	High Impedance Output Current	0 ≤ A, B ≤ V _{CC}			±1	
V _{IK}	Clamp Diode Voltage	V _{CC} = Min., I _{IN} = -18mA			-1.2	V
I _{OS}	Short Circuit Current ⁽³⁾	A (B) = 0V, B (A) = V _{CC}	100			mA
V _H	Input Hysteresis at Control Pins			150		mV
R _{ON}	Switch On-Resistance	V _{CC} = Min., V _{IN} = 0V, I _{ON} = 48mA		5	7	Ω
		V _{CC} = Min., V _{IN} = 2.4, I _{ON} = 15mA		10	15	
ΔR _{ON}	On-Resistance Match	V _{IN} = 3.0V, \bar{E} = LOW		1		

Notes:

- For Max. or Min. conditions, use appropriate value specified under Electrical Characteristics for applicable device type.
- Typical values are at V_{CC} = 3.3V, T_A = 25°C ambient temperature.
- Not more than one output should be shorted at one time. Duration of the test should not exceed one second.

Capacitance (T_A = 25°C, f = 1 MHz)

Parameters ⁽¹⁾	Description	Test Conditions	Typ.	Max.	Units
C _{IN}	Input Capacitance	V _{IN} = 0V		3	pF
C _{OFF}	Capacitance, Switch Off (Y)			17	
C _{ON}	Capacitance, Switch On			25	
C _{OFF}	Capacitance, Switch Off, (I _N)			8	

Note:

- This parameter is determined by device characterization but is not production tested.

Power Supply Characteristics

Parameters	Description	Test Conditions ⁽¹⁾		Min.	Typ. ⁽²⁾	Max.	Units
I _{CC}	Quiescent Power Supply Current	V _{CC} = Max.	V _{IN} = GND or V _{CC}		0.1	3.0	μA
ΔI _{CC}	Supply Current per Input @ TTL HIGH	V _{CC} = Max.	V _{IN} = V _{CC} - 0.6 ⁽³⁾			750	μA
I _{CCD}	Supply Current per Input per MHz ⁽⁴⁾	V _{CC} = Max., Input Pins Open \bar{E} = GND Control Input Toggling 50% Duty Cycle				0.25	mA/ MHZ

Notes:

- For Max. or Min. conditions, use appropriate value specified under Electrical Characteristics for the applicable device.
- Typical values are at V_{CC} = 3.3V, +25°C ambient.
- Per TTL driven input (V_{IN} = 3.0V, control inputs only); Y_A, Y_B, Y_C, Y_D pins do not contribute to I_{CC}.
- This current applies to the control inputs only and represent the current required to switch internal capacitance at the specified frequency. The Y_A, Y_B, Y_C, Y_D inputs generate no significant AC or DC currents as they transition. This parameter is not tested, but is guaranteed by design.

Switching Characteristics over Operating Range

Parameters	Description	Conditions ⁽¹⁾	Com.			Units
			Min.	Typ.	Max.	
T _{PLH}	Propagation Delay ^(2, 3) ; In to Y	C _L = 50pf R _L = 500Ω			0.25	ns
T _{PY}	Bus Enable Time; S to Y		1		4.5	
T _{PHZ} T _{PLZ}	Bus Disable Time; \bar{E} to Y		1		4.5	
X _{TALK}	Crosstalk	R _L = 100Ω, f = 30 MHz See Figure 2		-90		dB
O _{IRR}	Off Isolation	R _L = 100Ω, f = 30 MHz		-45		
B _W	-3dB Bandwidth	R _L = 100Ω, See Figure 2		213		MHz
t _{ON}	Turn On Time	R _L = 100Ω	1.0		5	ns
t _{OFF}	Turn Off Time	C _L = 35pF, See Figure 1	1.0		5	

Notes:

- See test circuit and waveforms.
- This parameter is guaranteed but not tested.
- The bus switch contributes no propagational delay other than the RC delay of the On-Resistance of the switch and the load capacitance. The time constant for the switch alone is of the order of 0.25ns for 50pF load. Since this time constant is much smaller than the rise/fall times of typical driving signals, it adds very little propagational delay to the system. Propagational delay of the bus switch when used in a system is determined by the driving circuit on the driving side of the switch and its interaction with the load on the driven side.

Applications

LAN Switch

The PI3L100 was designed to switch between various standards such as 10 Base-T, 100 Base-T, 100 VG-Any LAN, and Token Ring. Also general purpose applications such as loopback, line termination, and line clamps that might normally use mechanical relays are also ideal uses for this LAN Switch (see Figure 4). Generally speaking, this LAN Switch can be used for data rates to 200 Mbps and data signal levels from 0V to 3.6V.

LAN Standards	Data Rate per twisted pair (UTP)
10 Base-T	10 Mbps
100 Base-T	100 Mbps
100 VG-Any LAN	25 Mbps

V_{CC} Bias Voltage vs. R_{ON}

To keep R_{ON} to a minimum, it is recommended that the V_{CC} voltage be increased to a voltage between 3.3V and 3.6V. Ideally an input voltage between 0.2V and 3.6V will keep R_{ON} flat.

Signal Distortion

Distortion of the input signal is equated to 20 LOG ΔR_{ON}/R_L. So keeping R_{ON} flat as the data signal level varies is critical to low distortion. It should also be noted that increasing the data rate increases harmonic distortion which also effects the signal amplitude.

Test Circuits

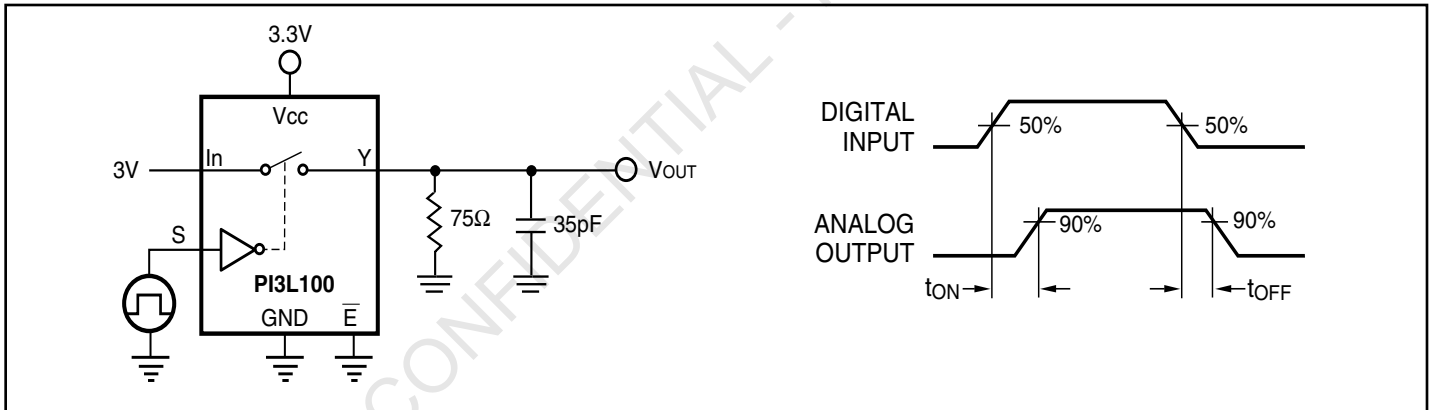

Figure 1. Switching Time

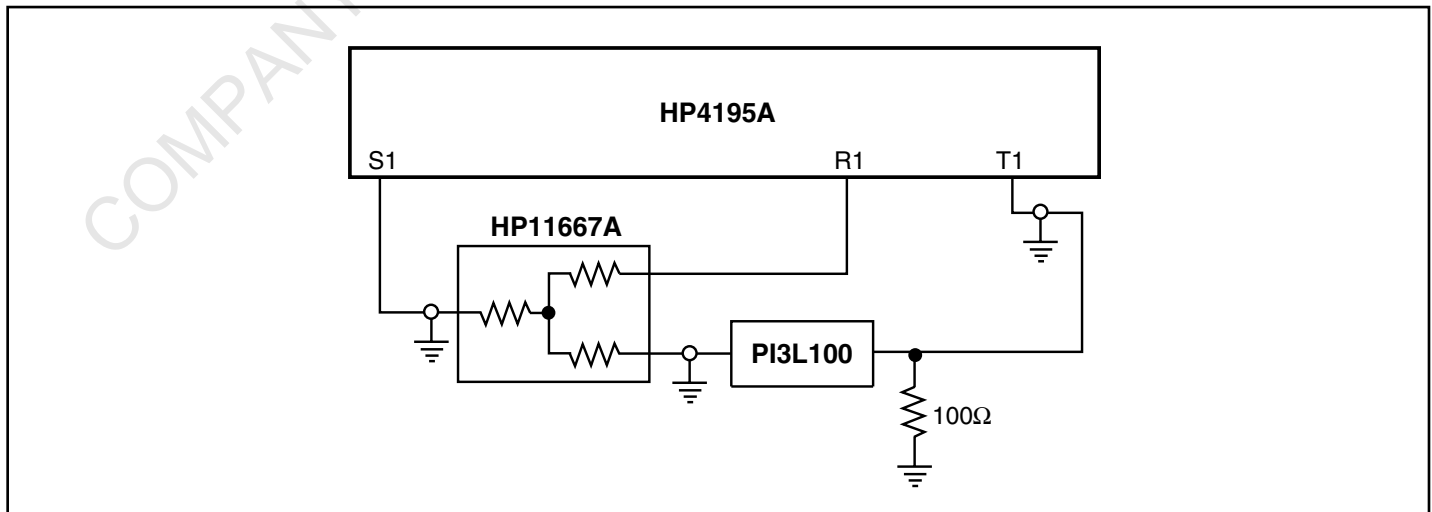

Figure 2. Gain/Phase Crosstalk, Off Isolation

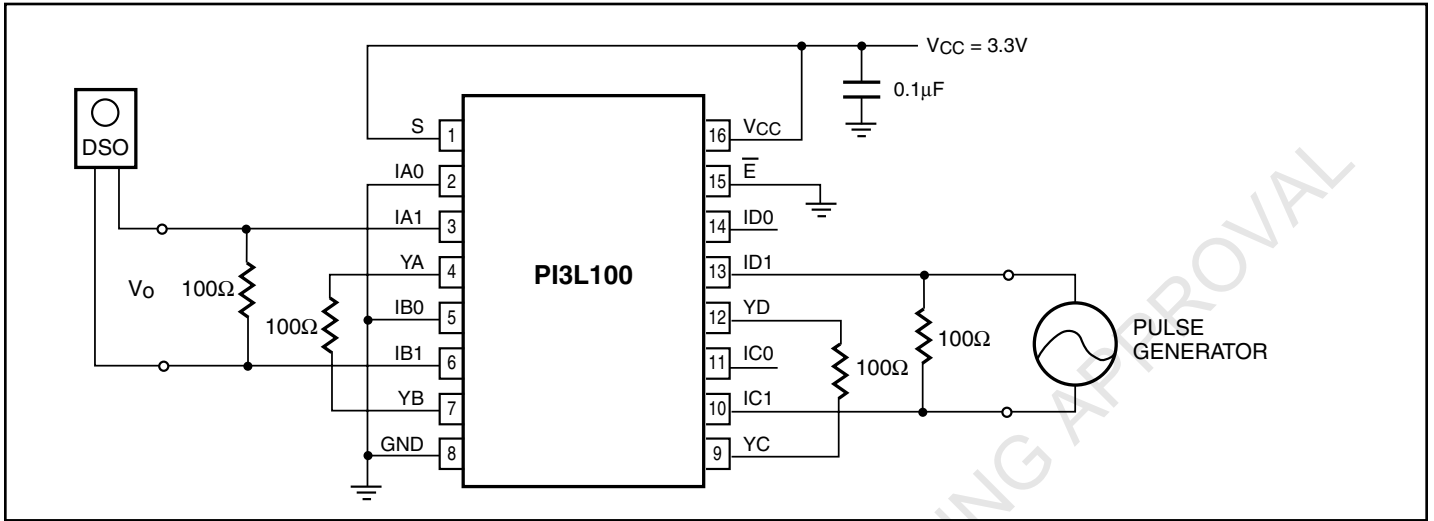

Figure 3. Differential Crosstalk Measurement

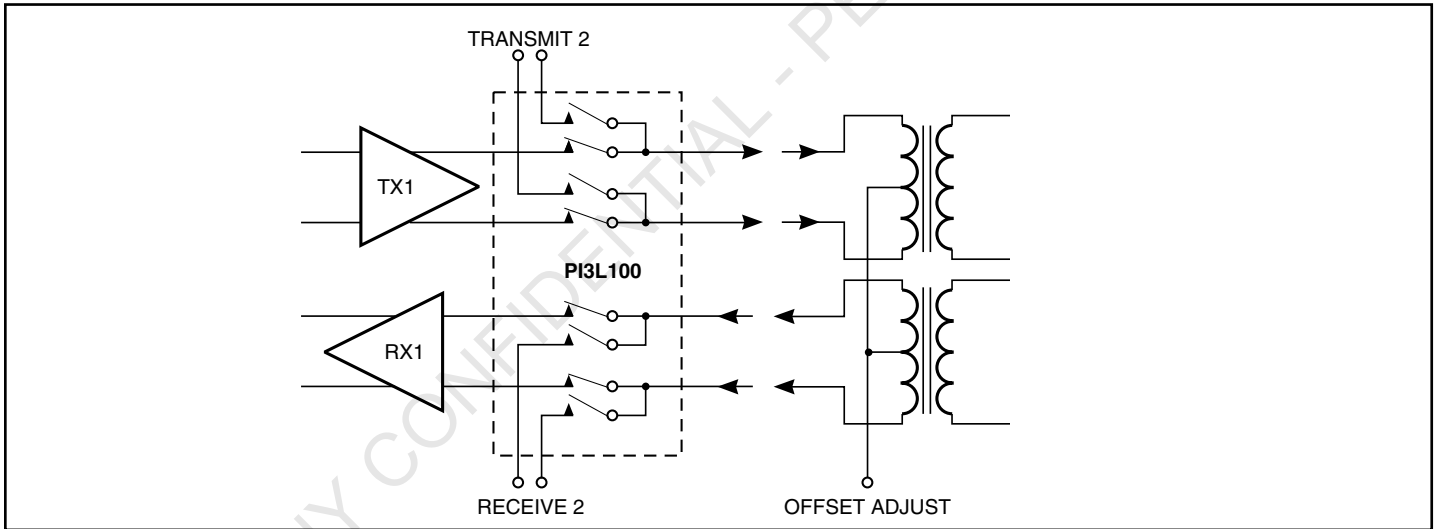

Figure 4a. Full Duplex Transceiver

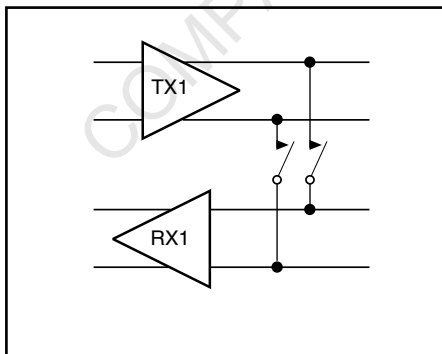

Figure 4b. Loop Back

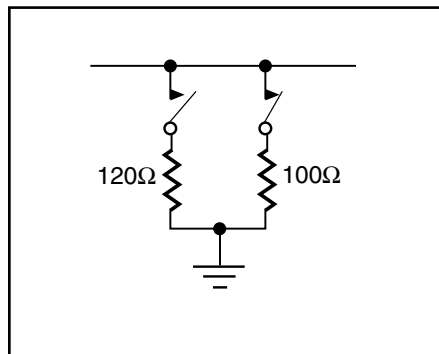

Figure 4c. Line Termination

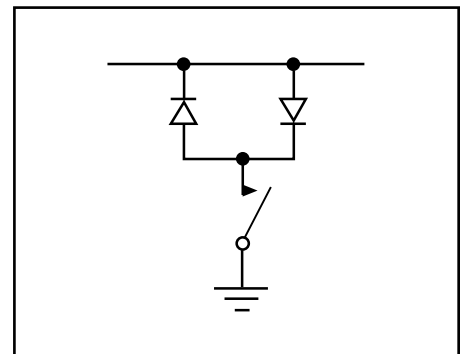
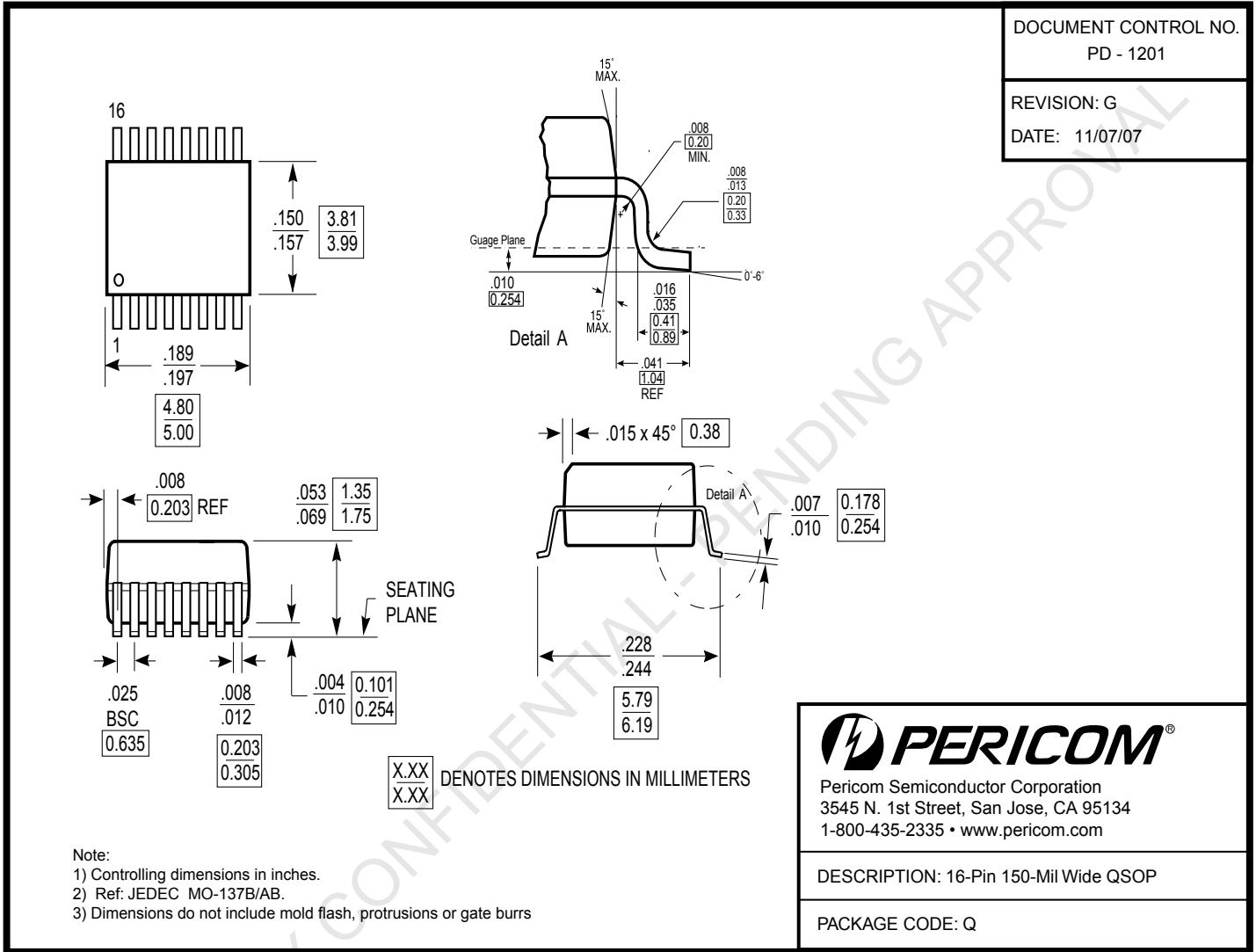

Figure 4d. Line Clamp

Packaging Mechanical: 16-pin QSOP (Q)



Ordering Information

Ordering Code	Packaging Code	Package Description
PI3L100QE	Q	Pb-free & Green, 16-pin 150-mil wide plastic QSOP

Notes:

- Thermal characteristics can be found on the company web site at www.pericom.com/packaging/
- E = Pb-free & Green
- Adding an X suffix = Tape/Reel

X-ON Electronics

Largest Supplier of Electrical and Electronic Components

Click to view similar products for [Multiplexer Switch ICs](#) category:

Click to view products by [Diodes Incorporated](#) manufacturer:

Other Similar products are found below :

[NLV74HC4066ADR2G](#) [HEF4051BP](#) [MC74HC4067ADTG](#) [DG508AAK/883B](#) [NLV14051BDG](#) [016400E](#) [PI3V512QE](#) [7705201EC](#)
[PI2SSD3212NCE](#) [PI3L100QE](#) [NLAS3257CMX2TCG](#) [PI5A3157BC6EX](#) [PI3V512QEX](#) [PI3DBS16213ZLEX](#) [PI3DBS16415ZHEX](#)
[PS509LEX](#) [MUX36S16IRSNR](#) [74LVC1G3157GM-Q10X](#) [TC7W53FK,LF](#) [CD4053BM96](#) [MC74HC4053ADWR2G](#) [MAX4051AEEE+](#)
[PI3L720ZHEX](#) [ADG1404YRUZ-REEL7](#) [ADG1208YRZ-REEL7](#) [CD4053BPWRG4](#) [ADG658TRUZ-EP](#) [FSA1256L8X_F113](#) [PI5V330QE](#)
[PI5V331QE](#) [5962-8771601EA](#) [ADG5249FBRUZ](#) [ADG1438BRUZ](#) [ADG5207BCPZ-RL7](#) [ADW54003-0](#) [AD7506JNZ](#) [AD7506KNZ](#)
[AD7506SQ](#) [AD8170AR](#) [AD8183ARUZ](#) [AD8184ANZ](#) [AD8185ARUZ](#) [AD8187ARUZ](#) [AD8188ARUZ](#) [AD8189ARUZ](#) [ADG1208YRUZ-](#)
[REEL7](#) [ADG1409YCPZ-REEL7](#) [ADG5209FBRUZ](#) [ADG1408YRUZ-REEL7](#) [ADG659YRUZ-REEL7](#)