

3.3V, 8-Channel, 2:1 Mux/DeMux Gigabit Ethernet LAN Switch with Single Enable and Enhanced ESD Protection

Features

- R_{ON} is 4Ω typical
- Low bit-to-bit skew: 200ps
- Low Crosstalk: -35dB @ 250MHz
- Near-Zero propagation delay: 250ps
- Switching speed: 9ns
- Channel On capacitance: 10pF (typical)
- Status Indicator LEDs Switched with Ethernet pairs
- V_{CC} Operating Range: +3.0V to +3.6V
- Enhanced ESD Protection:
 - 8kV (contact)⁽¹⁾
 - Switch pins: 1.1kV (machine model),
12kV (human body model)
- >550 MHz bandwidth (or data frequency)
- Packaging:
 - Pb-free and Green, 56-contact TQFN (ZF)

Applications

- Dual Physical Layer Device sharing to one interface connector
- Routes signals for 10/100/1000 Mbit Ethernet

Description

The PI3L500-A is a 8-Channel 2:1 multiplexer/demultiplexer LAN Switch with Hi-Z outputs. Industry leading advantages include a propagation delay of less than 250ps, resulting from its low channel resistance and I/O capacitance. The device multiplexes differential outputs from a Gigabit Ethernet transceiver (PHY) device to one of two corresponding B1 or B2 outputs. The switch is bidirectional and offers little or no attenuation of the high-speed signals at the outputs. It is designed for low bit-to-bit skew, high channel-to-channel noise isolation and is compatible with various standards, such as 10/100/1000 Base-T (Ethernet).

Generally, this part can be used to replace mechanical relays in low-voltage LAN applications that interface a physical layer over CAT 5 or CAT 6 unshielded twisted pair cable through an isolation transformer.

Note: 1. IEC 61000-4-2

Block Diagram

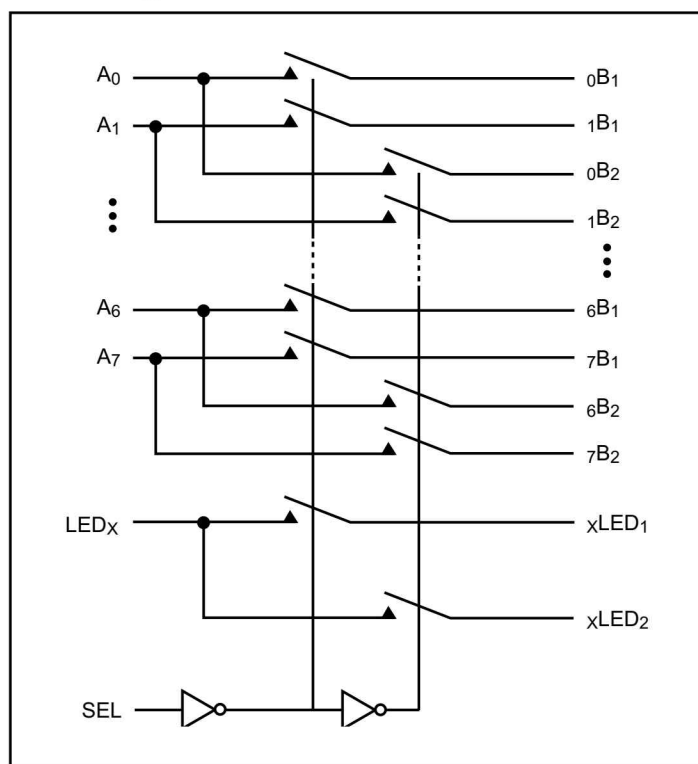

Pin Description

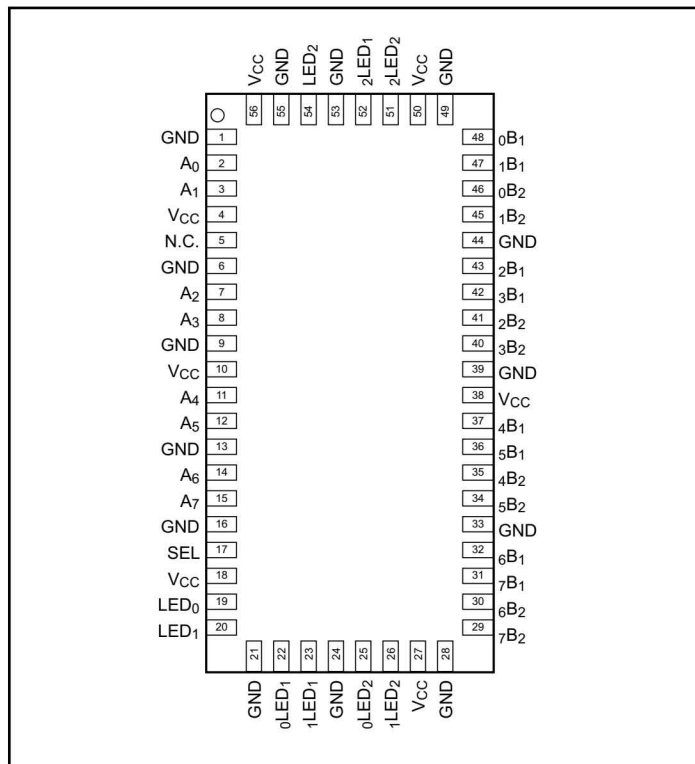

Pin Description

| Pin Name | Description |
|-------------------|------------------|
| A _X | DeMux Inputs |
| x _B Y | Mux Inputs |
| LED _Z | LED Demux Inputs |
| zLED _Y | LED Mux Inputs |
| GND | Ground |
| V _{CC} | Power |
| SEL | Select |

Truth Table

| SEL | Function |
|-----|---|
| L | A _X to x _B 1; LED _Z to zLED ₁ |
| H | A _X to x _B 2; LED _Z to zLED ₂ |

Maximum Ratings

(Above which useful life may be impaired. For user guidelines, not tested.)

| | |
|--|-----------------|
| Storage Temperature..... | -65°C to +150°C |
| Supply Voltage to Ground Potential | -0.5V to +4.0V |
| DC Input Voltage..... | -0.5V to +5.5V |
| DC Output Current..... | 120mA |
| Power Dissipation | 0.5W |

Note:

Stresses greater than those listed under MAXIMUM RATINGS may cause permanent damage to the device. This is a stress rating only and functional operation of the device at these or any other conditions above those indicated in the operational sections of this specification is not implied. Exposure to absolute maximum rating conditions for extended periods may affect reliability.

DC Electrical Characteristics for 1000 Base-T Ethernet Switching over Operating Range
 $(T_A = -40^\circ\text{C to } +85^\circ\text{C}, V_{CC} = 3.3\text{V} \pm 10\%)$

| Parameter | Description | Test Conditions ⁽¹⁾ | Min. | Typ. ⁽²⁾ | Max. | Units |
|-----------------------|--|---|------|---------------------|------|-------|
| V _{IH} | Input HIGH Voltage | Guaranteed HIGH level (Control Pins) | 2.0 | – | – | V |
| V _{IL} | Input LOW Voltage | Guaranteed LOW level (Control Pins) | –0.5 | – | 0.8 | |
| V _{IK} | Clamp Diode Voltage | V _{CC} = Max., I _{IN} = –18mA | – | –0.7 | –1.2 | |
| I _{IH} | Input HIGH Current | V _{CC} = Max., V _{IN} = V _{CC} | – | – | ±5 | µA |
| I _{IL} | Input LOW Current | V _{CC} = Max., V _{IN} = GND | – | – | ±5 | |
| R _{ON} | Switch On-Resistance ⁽³⁾ | V _{CC} = Min., 1.5V ≤ V _{IN} ≤ V _{CC} I _{IN} = –40mA | – | 4.0 | 6.5 | Ω |
| R _{FLAT(ON)} | On-Resistance Flatness ⁽³⁾ | V _{CC} = Min., V _{IN} @ 1.5V and V _{CC} I _{IN} = –40mA | – | 0.5 | – | |
| ΔR _{ON} | On-Resistance match from center ports to any other port ⁽³⁾ | V _{CC} = Min., 1.5V ≤ V _{IN} ≤ V _{CC} I _{IN} = –40mA | – | 0.4 | 1.0 | |

DC Electrical Characteristics for 10/100 Base-T Ethernet Switching over Operating Range
 $(T_A = -40^\circ\text{C to } +85^\circ\text{C}, V_{CC} = 3.3\text{V} \pm 10\%)$

| Parameter | Description | Test Conditions ⁽¹⁾ | Min. | Typ. ⁽²⁾ | Max. | Units |
|-----------------------|--|--|------|---------------------|------|-------|
| V _{IH} | Input HIGH Voltage | Guaranteed HIGH level (Control Pins) | 2.0 | – | – | V |
| V _{IL} | Input LOW Voltage | Guaranteed LOW level (Control Pins) | –0.5 | – | 0.8 | |
| V _{IK} | Clamp Diode Voltage | V _{CC} = Max., I _{IN} = –18mA | – | –0.7 | –1.2 | |
| I _{IH} | Input HIGH Current | V _{CC} = Max., V _{IN} = V _{CC} | – | – | ±5 | µA |
| I _{IL} | Input LOW Current | V _{CC} = Max., V _{IN} = GND | – | – | ±5 | |
| R _{ON} | Switch On-Resistance ⁽³⁾ | V _{CC} = Min., 1.25V ≤ V _{IN} ≤ V _{CC} I _{IN} = –10mA to –30mA | – | 4.0 | 6.5 | Ω |
| R _{FLAT(ON)} | On-Resistance Flatness ⁽³⁾ | V _{CC} = Min., V _{IN} @ 1.25V and V _{CC} I _{IN} = –10mA to –30mA | – | 0.5 | – | |
| ΔR _{ON} | On-Resistance match from center ports to any other port ⁽³⁾ | V _{CC} = Min., 1.25V ≤ V _{IN} ≤ V _{CC} I _{IN} = –10mA to –30mA | – | 0.4 | 1.0 | |

Capacitance (T_A = 25°C, f = 1MHz)

| Parameters ⁽⁴⁾ | Description | Test Conditions ⁽¹⁾ | Typ. | Max. | Units |
|---------------------------|--------------------------------|--------------------------------|------|------|-------|
| C _{IN} | Input Capacitance | V _{IN} = 0V | 2.0 | 3.0 | pF |
| C _{OFF(B1, B2)} | Port B Capacitance, Switch OFF | | 4.0 | 6.0 | |
| C _{ON(A/B)} | A/B Capacitance, Switch ON | | 10.0 | 11.0 | |

Notes:

- For max. or min. conditions, use appropriate value specified under Electrical Characteristics for the applicable device type.
- Typical values are at V_{CC} = 3.3V, T_A = 25°C ambient and maximum loading.
- Measured by the voltage drop between A and B pins at indicated current through the switch. ON resistance is determined by the lower of the voltages on the two (A & B) pins.
- This parameter is determined by device characterization but is not production tested.

Power Supply Characteristics

| Parameters | Description | Test Conditions ⁽¹⁾ | Min. | Typ. ⁽²⁾ | Max. | Units |
|-----------------|--------------------------------|--|------|---------------------|------|-------|
| I _{CC} | Quiescent Power Supply Current | V _{CC} = Max., V _{IN} = GND or V _{CC} | — | 0.5 | 3.5 | mA |

Dynamic Electrical Characteristics Over the Operating Range (T_A = -40°C to +85°C, V_{CC} = 3.3V ±10%, GND = 0V)

| Parameter | Description | Test Conditions ⁽¹⁾ | Min. | Typ. ⁽²⁾ | Max. | Units |
|-------------------|-------------------------------|-----------------------------------|------|---------------------|------|-------|
| X _{TALK} | Crosstalk ⁽³⁾ | R _L = 100Ω, f = 250MHz | — | -35 | — | dB |
| O _{IRR} | OFF Isolation ⁽³⁾ | | — | -32 | — | |
| BW | Bandwidth -3dB ⁽³⁾ | R _L = 100Ω | — | 350 | — | MHz |

Switching Characteristics

| Parameter | Description | Min. | Typ. ⁽²⁾ | Max. | Units |
|-------------------------------------|--|------|---------------------|------|-------|
| t _{PD} | Propagation Delay ^(3,4) | — | 0.25 | | ns |
| t _{PZH} , t _{PZL} | Line Enable Time - SEL to A _N , B _N | 0.5 | — | 15.0 | |
| t _{PHZ} , t _{PLZ} | Line Disable Time - SEL to A _N , B _N | 0.5 | — | 9.0 | |
| t _{SK(o)} | Output Skew between center port (A ₄ to A ₅) to any other port ⁽³⁾ | — | 0.1 | 0.2 | |
| t _{SK(p)} | Skew between opposite transitions of the same output (t _{PHL} - t _{PLH}) ⁽³⁾ | — | 0.1 | 0.2 | |

Notes:

- For max. or min. conditions, use appropriate value specified under Electrical Characteristics for the applicable device type.
- Typical values are at V_{CC} = 3.3V, T_A = 25°C ambient and maximum loading..
- Guaranteed by design.
- The bus switch contributes no propagational delay other than the RC delay of the ON resistance of the switch and the load capacitance. The time constant for the switch alone is of the order of 0.25ns for 10pF load. Since this time constant is much smaller than the rise/fall times of typical driving signals, it adds very little propagational delay to the system. Propagational delay of the bus switch when used in a system is determined by the driving circuit on the driving side of the switch and its interactions with the load on the driven side.

Test Circuit for Electrical Characteristics

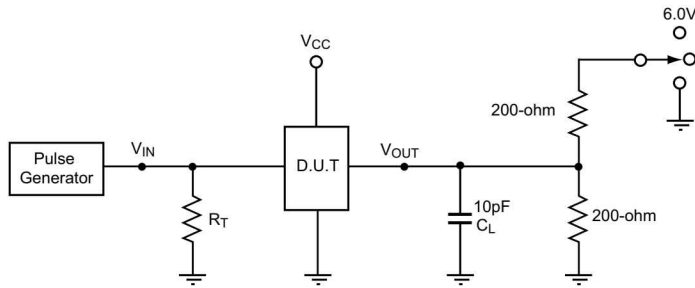

Switch Positions

| Test | Switch |
|--|--------|
| t_{PLZ} , t_{PZL} (output on B-side) | 6.0V |
| t_{PHZ} , t_{PZH} (output on B-side) | GND |
| Prop Delay | Open |

Notes:

C_L = Load capacitance: includes jig and probe capacitance.

R_T = Termination resistance: should be equal to Z_{OUT} of the Pulse Generator

Test Circuit for Dynamic Electrical Characteristics

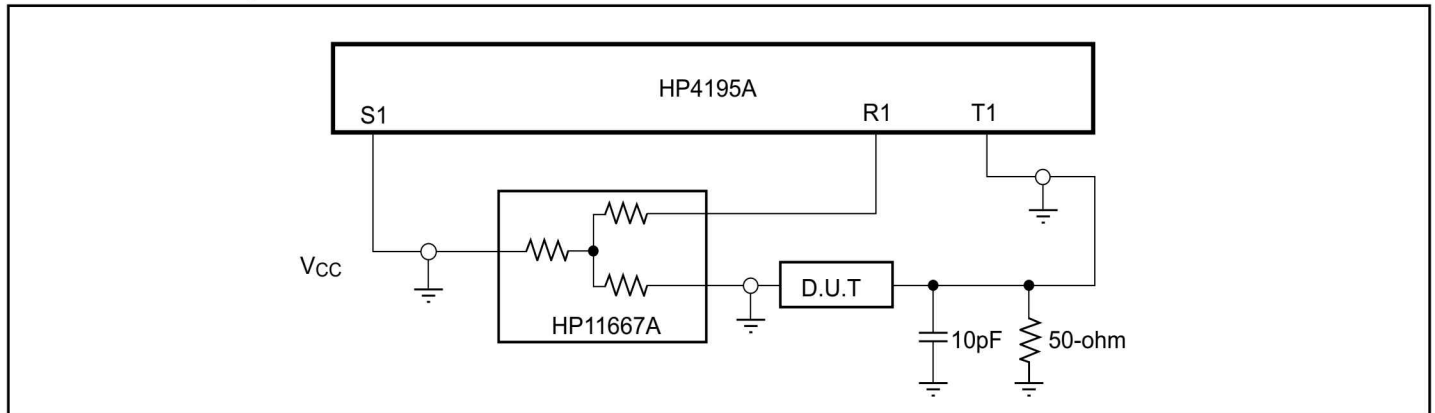

Switching Waveforms

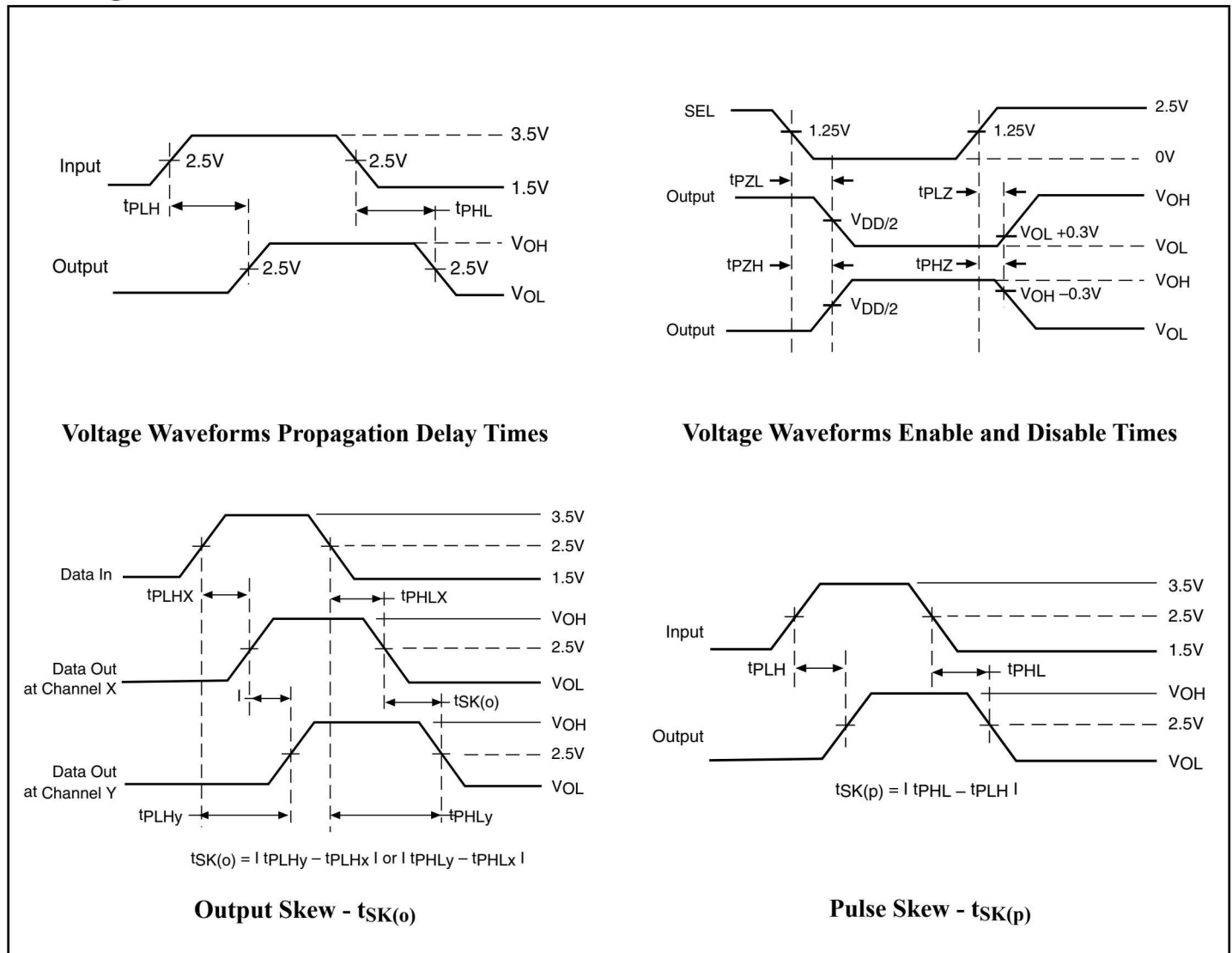

Notes:

Waveform 1 is for an output with internal conditions such that the output is low except when disabled by the output control.

Waveform 2 is for an output with internal conditions such that the output is high except when disabled by the output control.

All input impulses are supplied by generators having the following characteristics: $PRR \leq \text{MHz}$, $Z_O = 50\Omega$, $t_R \leq 2.5\text{ns}$, $t_F \leq 2.5\text{ns}$.

The outputs are measured one at a time with one transition per measurement.

Applications Information

Logic Inputs

The logic control inputs can be driven up to +3.6V regardless of the supply voltage. For example, given a +3.3V supply, the output enables or select pins may be driven low to 0V and high to 3.6V. Driving IN Rail-to-Rail® minimizes power consumption.

Power-Supply Sequencing

Proper power-supply sequencing is advised for all CMOS devices. It is recommended to always apply V_{CC} before applying signals to the input/output or control pins.

Rail-to-Rail is a registered trademark of Nippon Motorola, Ltd

Packaging Mechanical: 56-Contact TQFN (ZF)

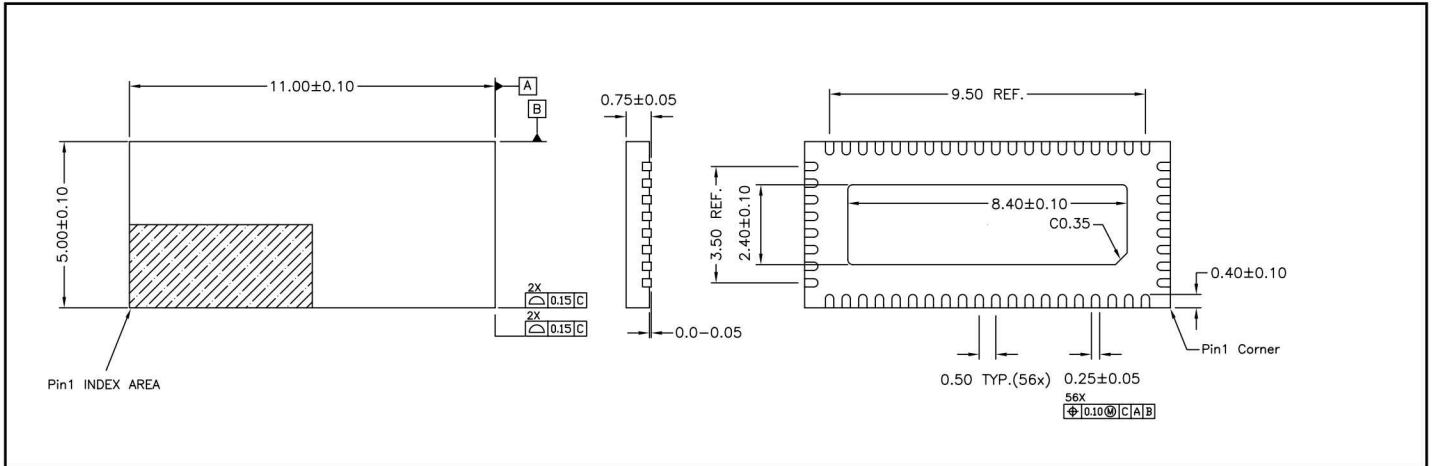

Ordering Information

| Ordering Number | Package Code | Package Description |
|-----------------|--------------|----------------------------------|
| PI3L500-AZFE | ZF | Pb-free & Green, 56-contact TQFN |

Notes:

Thermal characteristics can be found on the company web site at www.pericom.com/packaging/
 Add 'X' for Tape and Reel

X-ON Electronics

Largest Supplier of Electrical and Electronic Components

Click to view similar products for [Multiplexer Switch ICs](#) category:

Click to view products by [Diodes Incorporated](#) manufacturer:

Other Similar products are found below :

[DG508AAK/883B](#) [NLAS5223CMUTAG](#) [DG509ACJ](#) [PI3V512QE](#) [7705201EC](#) [PI2SSD3212NCE](#) [NLAS3257CMX2TCG](#)
[PI3DBS16213ZLEX](#) [PI3DBS16415ZHEX](#) [PI3DBS12412AZHEX](#) [DG407DY](#) [ISL43741IR](#) [ISL43L740IR](#) [ISL54200IRZ](#) [ISL84780IR](#)
[MC74LVX4066DR2](#) [NCN2411MTTWG](#) [NLVHC4052ADTR2G](#) [TMUXHS221NKGR](#) [TMUX7221DGSR](#) [TMUX8213PWR](#) [74HC4052BZX](#)
[ADG1408SRUZ-EP-RL7](#) [ADG1408YRUZ-REEL](#) [74HC4067PW-Q100J](#) [TMUX2889YBHR](#) [HD3SS213ZXHR](#) [TMUXHS4412RUAR](#)
[TMUXHS221NKGT](#) [TMUX131RMGR](#) [TMUX6209PWR](#) [MAX4052AESE+T](#) [MAX306EUI+T](#) [TMUX4827YBHR](#) [TMUXHS4412IRUAR](#)
[TS3DV642RUARQ1](#) [PI3L500-AZFEX](#) [PI3WVR31310AZLEX](#) [PI3V312QEX](#) [PI3B3257QEX-2017](#) [TC7W53FK,LF](#) [74LVC1G3157GM,132](#)
[74LVC2G53DC,125](#) [ADG439FBRZ-REEL](#) [PI5V330SQE](#) [CD4053BM96](#) [CBTL06GP213EEJ](#) [74LVC1G53DC,125](#) [74LVC1G3157GM,115](#)
[MAX4634ETB+T](#)