

PI3PCIE3415A

3.3V, PCI Express 3.0 2-Lane, 2:1 Mux/DeMux Switch

Features

- Four Differential Channel, 2:1 Mux/DeMux
- PCI Express® 3.0 Performance, 8.0Gbps
- Pinout Optimized for Placement Between two PCIe Slots
- Bidirectional Operation
- Low Bit-to-Bit Skew, 10ps max
- Low Crosstalk: -48dB @ 4GHz
- High Off Isolation: -22dB @ 4GHz
- Low Insertion Loss: -1.2dB @ 4GHz
- Return Loss: -15dB @ 4GHz
- V_{DD} Operating Range: +3.3V
- Industrial Temperature Range: -40°C to 85°C
- ESD Tolerance: 1.5kV HBM
- Low Channel-to-Channel Skew, 20ps max
- Totally Lead-Free & Fully RoHS Compliant (Notes 1 & 2)
- Halogen and Antimony Free. “Green” Device (Note 3)
- Packaging (Pb-free & Green):
 - 42-contact, TQFN (ZH42), 3.5mm × 9mm

Application

Routing of PCI Express 3.0, DP1.2, USB3.0, SAS2.0, SATA3.0, XAUI, RXAUI signals with low signal attenuation.

Truth Table

Function	SEL
xIy to xOay	L
xIy to xOby	H

Description

The PI3PCIE3415A is an 8-to-4 differential channel multiplexer/demultiplexer switch. This solution can switch two full PCI Express 3.0 lanes to one of two locations. Using a unique design technique, Diodes is able to minimize the impedance of the switch so that the attenuation observed through the switch is negligible. The unique design technique also offers a layout targeted for PCI Express signals, which minimizes the channel-to-channel skew as well as channel-to-channel crosstalk as required by the PCI Express specification.

Block Diagram

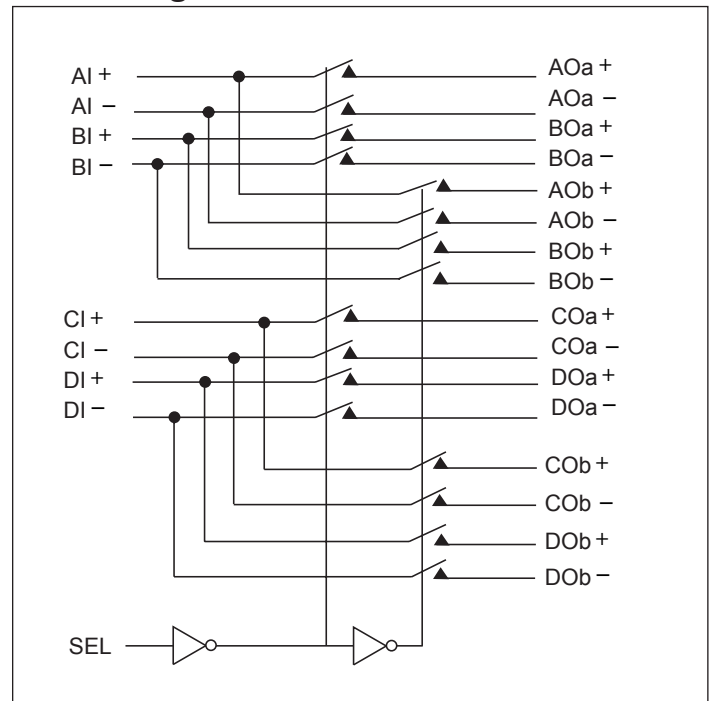

Notes:

1. No purposely added lead. Fully EU Directive 2002/95/EC (RoHS), 2011/65/EU (RoHS 2) & 2015/863/EU (RoHS 3) compliant.
2. See <https://www.diodes.com/quality/lead-free/> for more information about Diodes Incorporated’s definitions of Halogen- and Antimony-free, “Green” and Lead-free.
3. Halogen- and Antimony-free “Green” products are defined as those which contain <900ppm bromine, <900ppm chlorine (<1500ppm total Br + Cl) and <1000ppm antimony compounds.

PCI Express is a registered trademark of PCI-SIG.

Pin Configuration

42-TQFN (ZH) Top-Side View

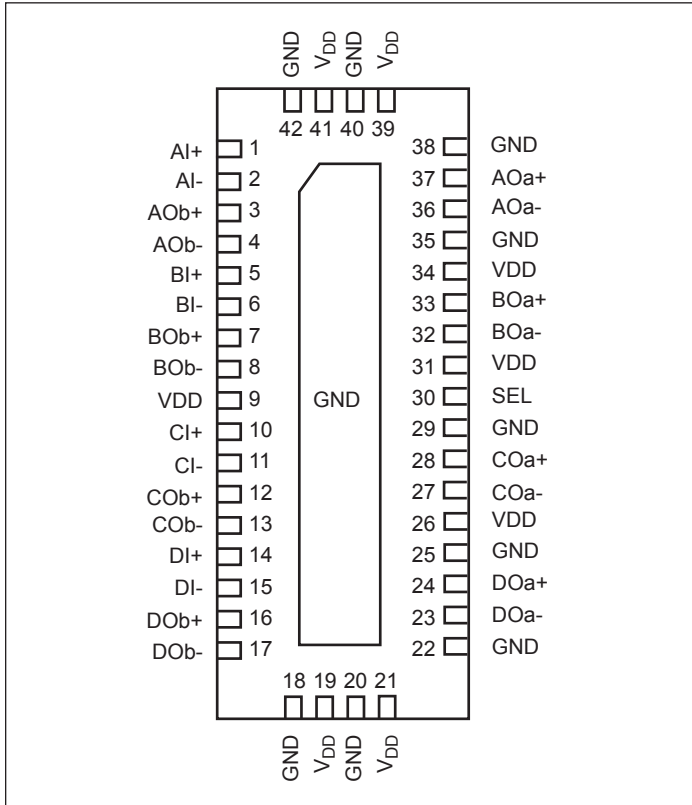

Pin Descriptions

Pin#	Pin Name	Type	Description
1, 2	AI+, AI-	Differential I/O	Differential I/O pair from PCIe signal source. Signal is routed to the AOa+, AOa- pin respectively when SEL=0. Signal is routed to the AOOb+, AOOb- pin respectively when SEL = 1.
37, 36	AOa+, AOa-	Differential I/O	Differential analog pass-through I/O. Signal from AI+ and AI- is routed to AOa+ and AOa- respectively when SEL=0.
3, 4	AOOb+, AOOb-	Differential I/O	Differential analog pass-through I/O. Signal from AI+ and AI- is routed to AOOb+ and AOOb- respectively when SEL=1.
5, 6	BI+, BI-	Differential I/O	Differential I/O pair from PCIe signal source. Signal is routed to the BOa+, BOa- pin respectively when SEL=0. Signal is routed to the BOOb+, BOOb- pin respectively when SEL = 1.
33, 32	BOa+, BOa-	Differential I/O	Differential analog pass-through I/O. Signal from BI+ and BI- is routed to BOa+ and BOa- respectively when SEL=0.
7, 8	BOOb+, BOOb-	Differential I/O	Differential analog pass-through I/O. Signal from BI+ and BI- is routed to BOOb+ and BOOb- respectively when SEL=1.
10, 11	CI+, CI-	Differential I/O	Differential I/O pair from PCIe signal source. Signal is routed to the COa+, COa- pin respectively When SEL=0. Signal is routed to the COOb+, COOb- pin respectively when SEL = 1.

Pin Descriptions Cont.

Pin#	Pin Name	Type	Description
28, 27	COa+, COa-	Differential I/O	Differential analog pass-through I/O. Signal from CI+ and CI- is routed to COa+, COa- pin respectively when SEL = 0.
12, 13	COb+, COb-	Differential I/O	Differential analog pass-through I/O. Signal from CI+ and CI- is routed to COb+, COb- pin respectively when SEL = 1.
14, 15	DI+, DI-	Differential I/O	Differential I/O pair from PCIE signal source. Signal is routed to the DOa+, DOa- pin respectively when SEL=0. Signal is routed to the DOb+, DOb- pin respectively when SEL = 1.
24, 23	DOa+, DOa-	Differential I/O	Differential analog pass-through I/O. Signal from DI+ and DI- is routed to DOa+, DOa- pin respectively when SEL = 0.
16, 17	DOb+, DOb-	Differential I/O	Differential analog pass-through I/O. Signal from DI+ and DI- is routed to DOb+, DOb- pin respectively when SEL = 1.
30	SEL	3.6V Tolerant Low-voltage Single-ended Input	SEL controls the mux through a flow-through latch.
9, 19, 21, 26, 31, 34, 39, 41	VDD	Power Supply	Power, 3.3V ±10%
18, 20, 22, 25, 29, 35, 38, 40, 42	GND	Power Supply	Power ground

Maximum Ratings

(Above which useful life may be impaired. For user guidelines, not tested.)

Storage Temperature	-65°C to +150°C
Supply Voltage to Ground Potential	-0.5V to +3.7V
Channel DC Input Voltage	-0.5V to 1.5V
DC Output Current	120mA
SEL DC Input Voltage	-0.5V to 3.7V
Junction Temperature	125°C

Note: Stresses greater than those listed under MAXIMUM RATINGS may cause permanent damage to the device. This is a stress rating only and functional operation of the device at these or any other conditions above those indicated in the operational sections of this specification is not implied. Exposure to absolute maximum rating conditions for extended periods may affect reliability.

Electrical Characteristics Recommended Operating Conditions

Symbol	Parameter	Conditions	Min.	Typ.	Max.	Units
V _{DD}	3.3V Power Supply	—	3.0	3.3	3.6	V
I _{DD}	Total Current from V _{DD} 3.3V Supply	SEL = 0V or V _{DD}	0	0.15	1	mA
T _A	Operating Temperature Range	—	-40	—	85	°C

DC Electrical Characteristics (T_A = -40°C to +85°C, V_{DD} = 3.3V ± 10%)

Parameter	Description	Test Conditions	Min.	Typ. ⁽¹⁾	Max.	Units
V _{IH-SEL}	Input High Level, SEL Input	—	2.0	—	3.6	V
V _{IL-SEL}	Input Low Level, SEL Input	—	0	—	0.8	V
I _{IN_SEL}	Input Leakage Current, SEL Input	Measured with input at V _{IH-SEL} max and V _{IL-SEL} min	-10	—	10	μA
I _{IH}	Input High Current, xI, xO	V _{DD} = Max, V _{IN} = 1.5V	-10	—	10	μA
I _{IL}	Input Low Current, xI, xO	V _{DD} = Max, V _{IN} = 0V	-10	—	10	μA
I _{IH}	Input High Current, SEL	V _{DD} = Max, V _{IN} = V _{DD}	-5	—	5	μA
I _{IL}	Input Low Current, SEL	V _{DD} = Max, V _{IN} = 0V	-5	—	5	μA
I _{OZH}	HighZ High Current xOa, xOb	V _{DD} = Max, V _{IN} = 1.5V	-10	—	10	μA
I _{OZL}	HighZ Low Current xOa, xOb	V _{DD} = Max, V _{IN} = 0V	-10	—	10	μA

Note:

1. Typical values are at V_{DD} = 3.3V, T_A = 25°C ambient and maximum loading.

Dynamic Electrical Characteristics for xI+/-, xOy+/-

Parameter	Description	Test Conditions	Min.	Typ. ⁽¹⁾	Max.	Units
DDIL	Differential Insertion Loss	f = 50MHz -1.25GHz f = 1.25GHz - 2.5GHz f = 2.5GHz - 4GHz f = 5.0GHz	—	-0.8 -1.1 -1.2 -1.7	-1.0 -1.3 -1.5 -2.0	dB
DDIL _{OFF}	Differential Off Isolation	f = 0 to 4.0GHz	-25.8 -20.6 -17.6 -15.4	-32.2 -25.8 -22.0 -19.3	—	
DDRL	Differential Return Loss	f = 50MHz - 1.25GHz f = 1.25GHz - 2.5GHz f = 2.5GHz - 4GHz f = 5.0GHz	-18.2 -16.8 -12 -8	-22.7 -21.0 -15.0 -10.0	—	
DDNEXT	Near End Crosstalk	f = 50MHz -1.25GHz f = 1.25GHz - 2.5GHz f = 2.5GHz - 4GHz f = 5.0GHz	-44.8 -41.6 -38.4 -36	-56 -52 -48 -45	—	
BW	Bandwidth -3dB	—	—	8.4	—	

Switching Characteristics

Parameter	Description	Test Conditions	Min.	Typ.	Max.	Units
t _{PZH} , t _{PZL}	Line Enable Time - SEL to xI+/-, xOy+/-	See "Test Circuit for Electrical Characteristics"	0.5	15	25	ns
t _{PHZ} , t _{PLZ}	Line Disable Time - SEL to xI+/-, xOy+/-	See "Test Circuit for Electrical Characteristics"	0.5	5	25	ns
t _{PLH}	Propagation Delay, LOW to HIGH	—	17	—	36	ps
t _{PHL}	Propagation Delay, HIGH to LOW	—	21	—	39	ps
t _{b-b}	Bit-to-Bit Skew Within Same Differential Pair	See "Test Circuit for Electrical Characteristics"	—	4	10	ps
t _{ch-ch}	Channel-to-Channel Skew	See "Test Circuit for Electrical Characteristics"	—	—	20	ps

PI3PCIE3415A

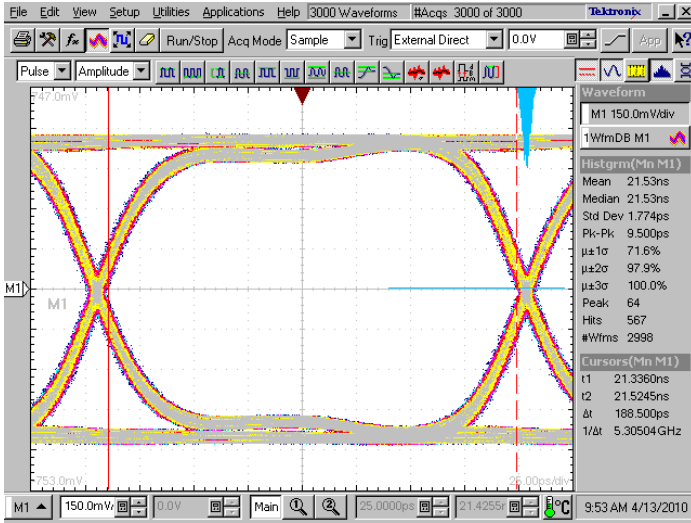

5.0Gbps RX Signal Eye Without PI3PCIE3415A

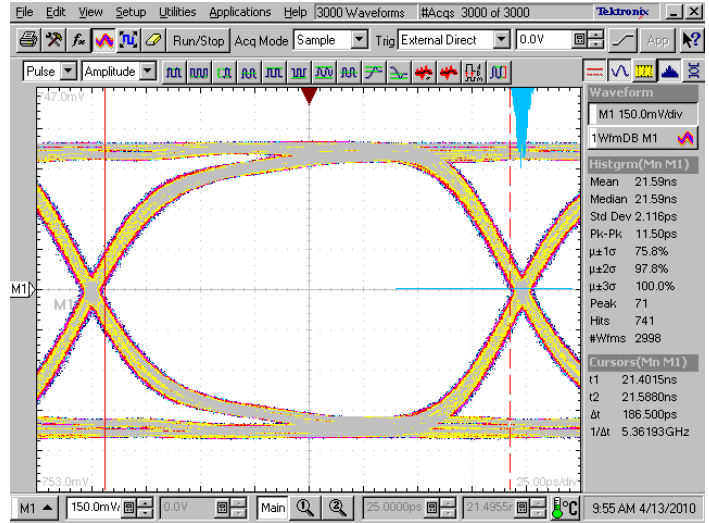

5.0Gbps RX Signal Eye With PI3PCIE3415A

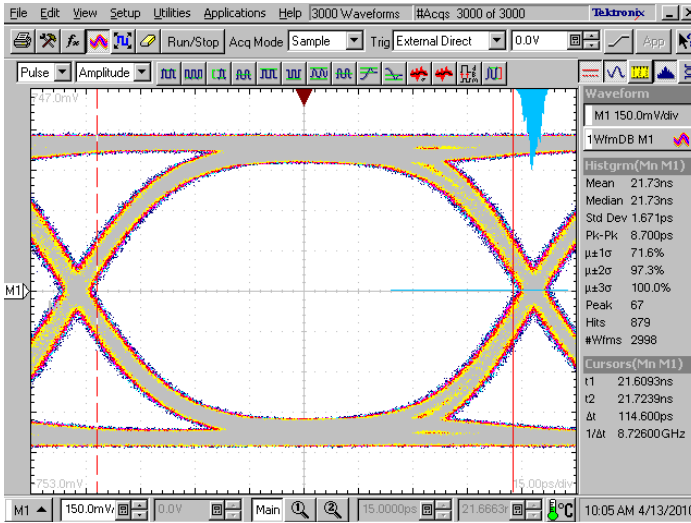

8.0Gbps RX Signal Eye Without PI3PCIE3415A

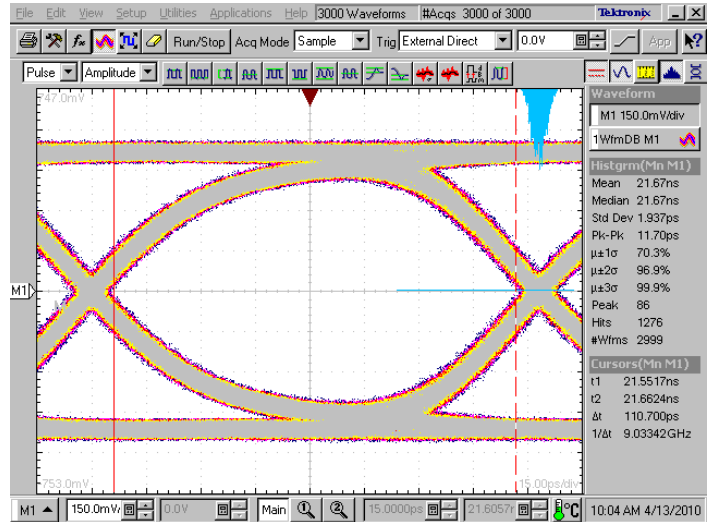

8.0Gbps RX Signal Eye With PI3PCIE3415A

PI3PCIE3415A

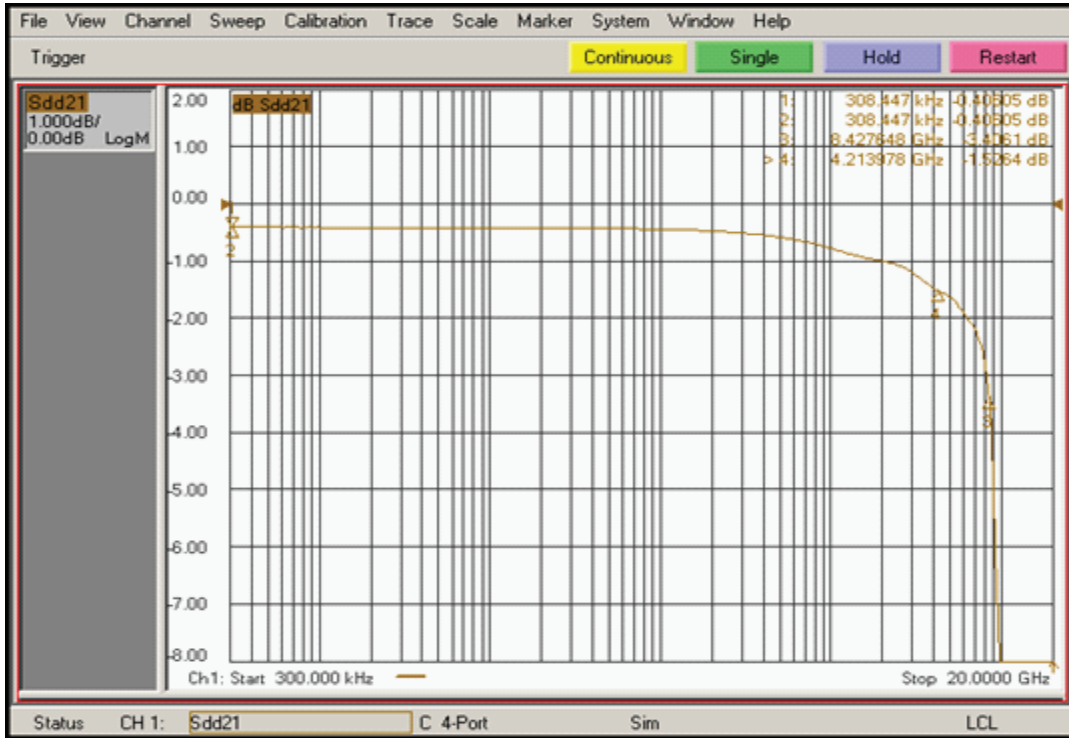

Differential Insertion Loss

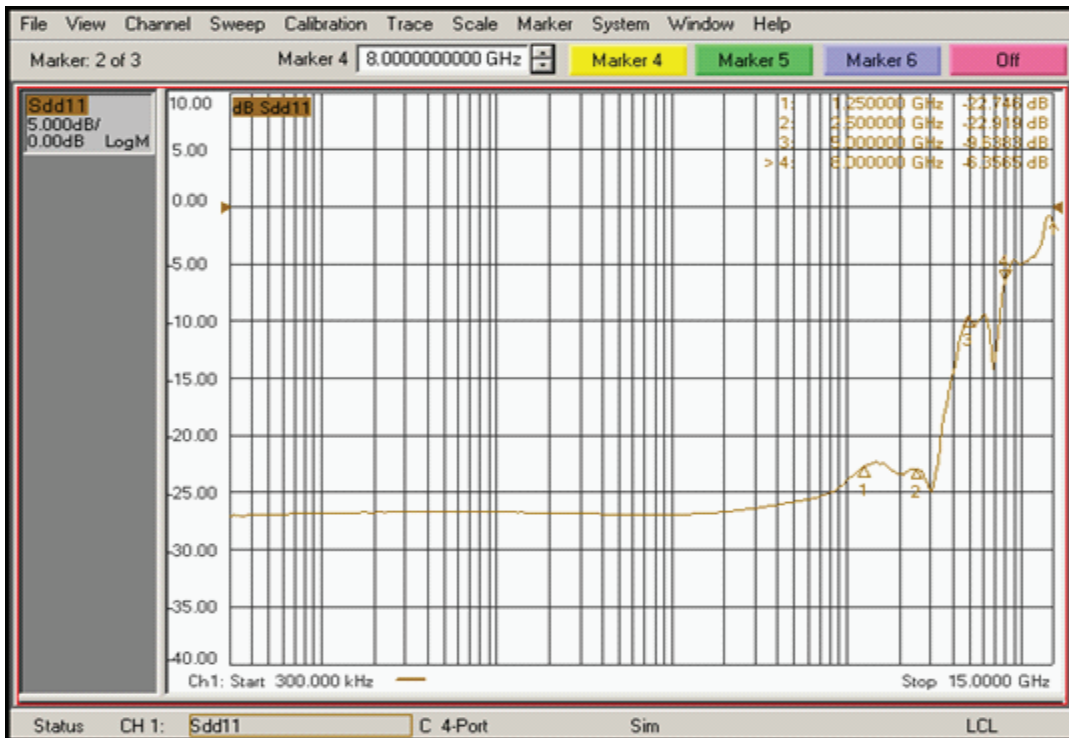

Differential Return Loss

PI3PCIE3415A

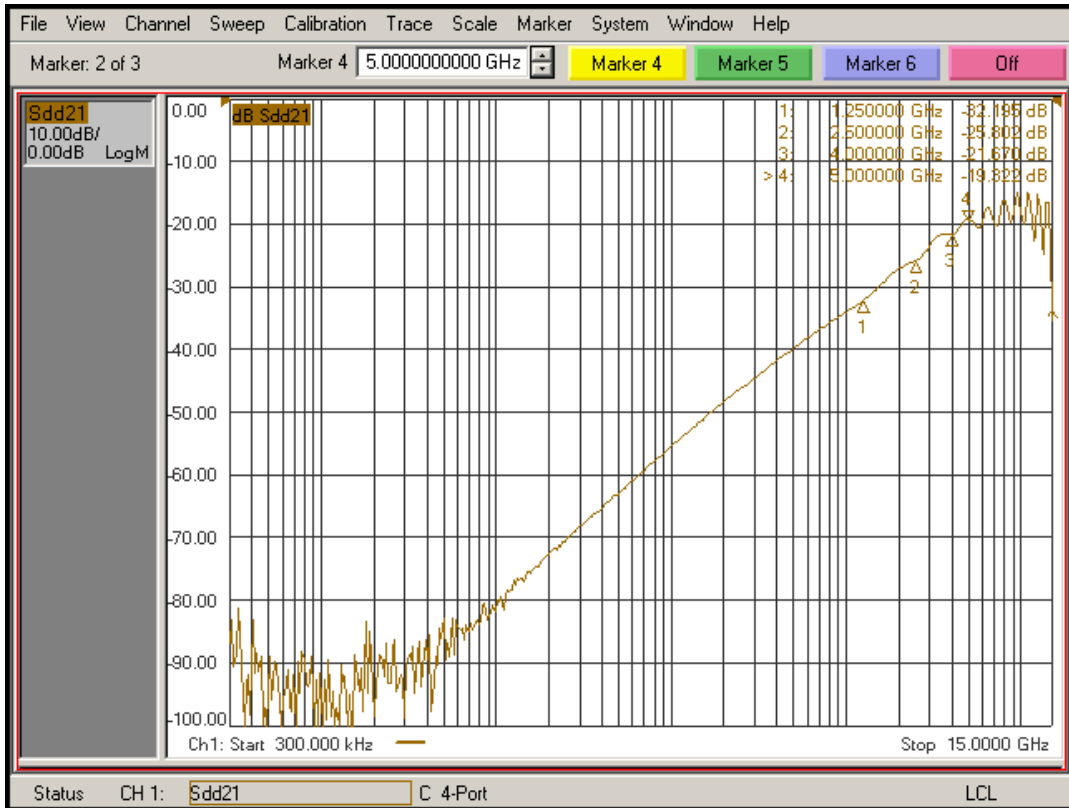

Differential Off Isolation

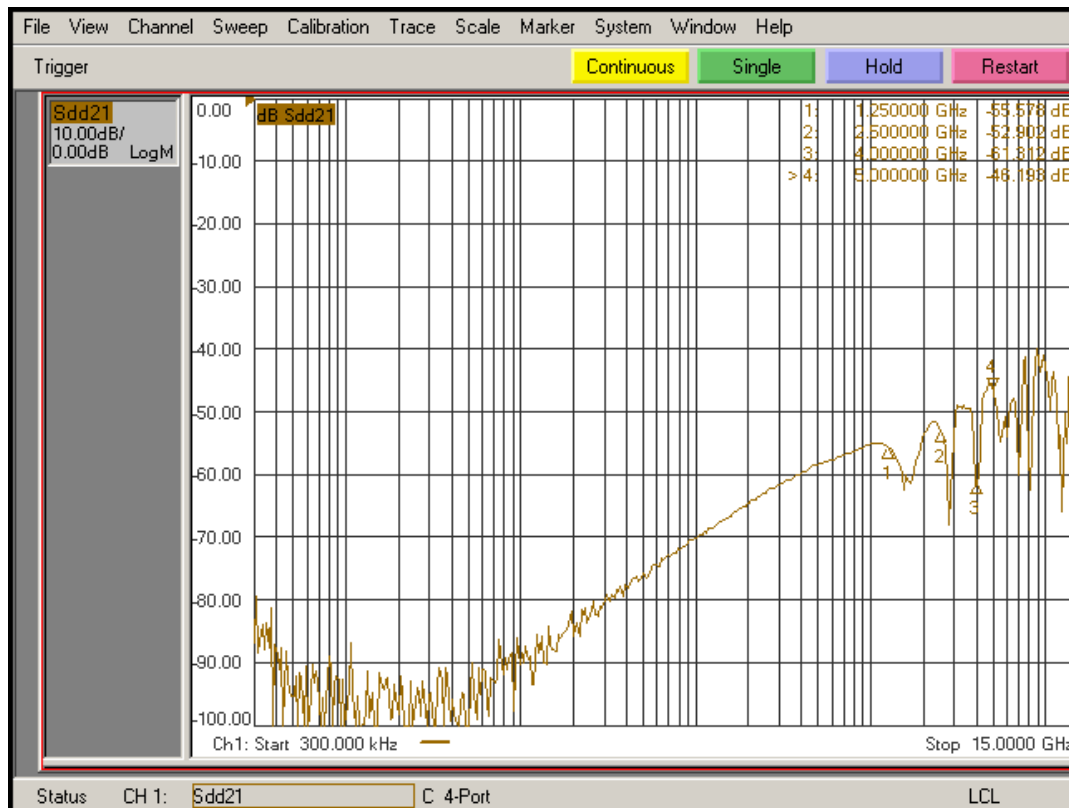

Differential Crosstalk

Test Circuit for Electrical Characteristics(1-5)

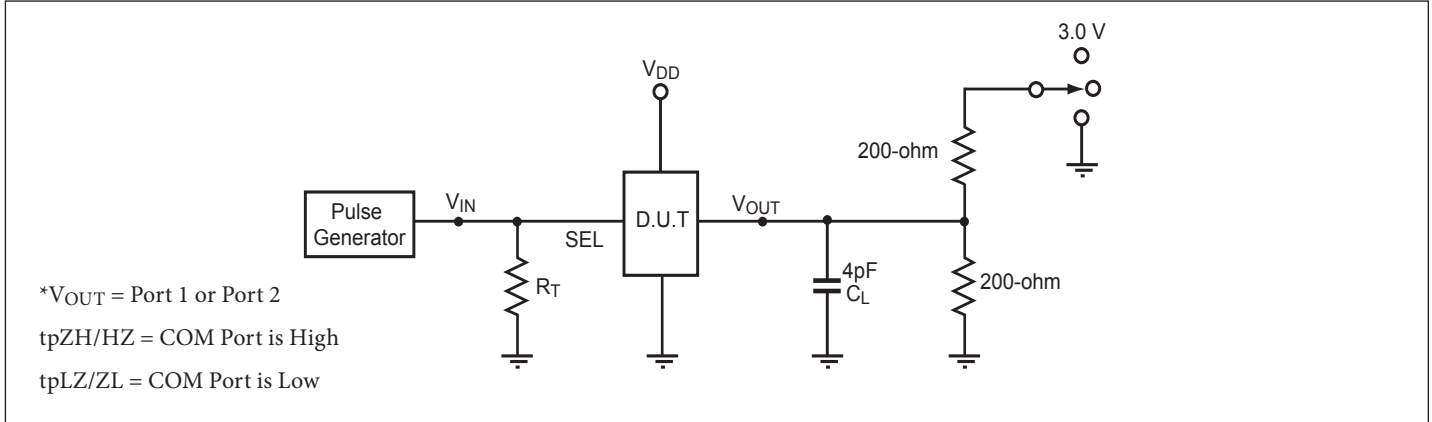

Notes:

1. C_L = Load capacitance: includes jig and probe capacitance.
2. R_T = Termination resistance: should be equal to Z_{OUT} of the Pulse Generator.
3. Output 1 is for an output with internal conditions such that the output is low except when disabled by the output control.
 Output 2 is for an output with internal conditions such that the output is high except when disabled by the output control.
4. All input impulses are supplied by generators having the following characteristics: PRR ≤ MHz, Z_O = 50Ω, t_R ≤ 2.5ns, t_F ≤ 2.5ns.
5. The outputs are measured one at a time with one transition per measurement.

Switch Positions

Test	Switch
t _{pLZ} , t _{pZL}	3.0V
t _{pHZ} , t _{pZH}	GND

Switching Waveforms

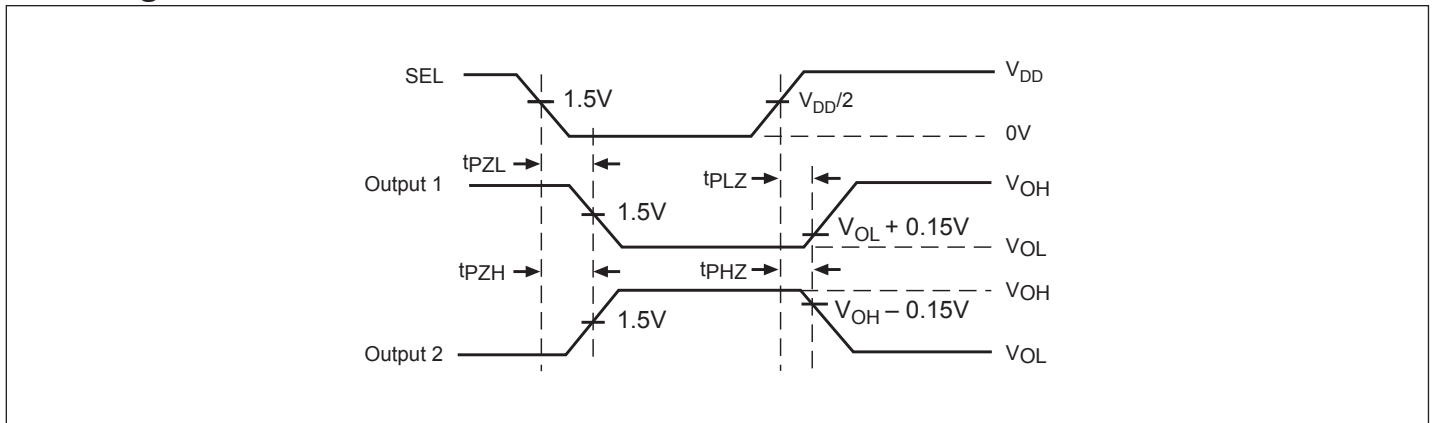

Voltage Waveforms Enable and Disable Times

PI3PCIE3415A

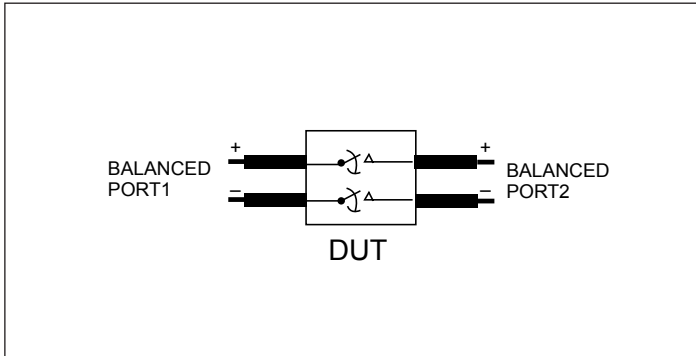

Differential Insertion Loss and Return Test Circuit

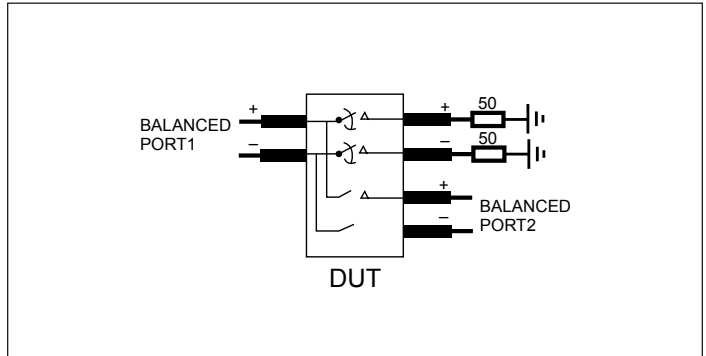

Differential Off Isolation Test Circuit

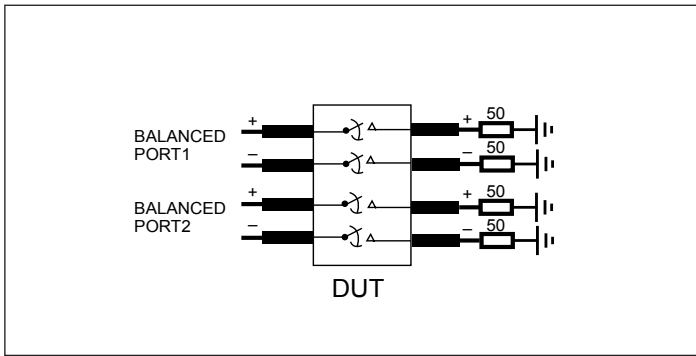

Differential Near End Xtalk Test Circuit

Part Marking

ZH Package

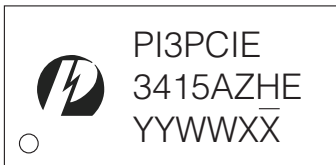

YY: Year

WW: Workweek

1st X: Assembly Code

2nd X: Fab Code

PI3PCIE3415A

Packaging Mechanical: 42-TQFN (ZH)

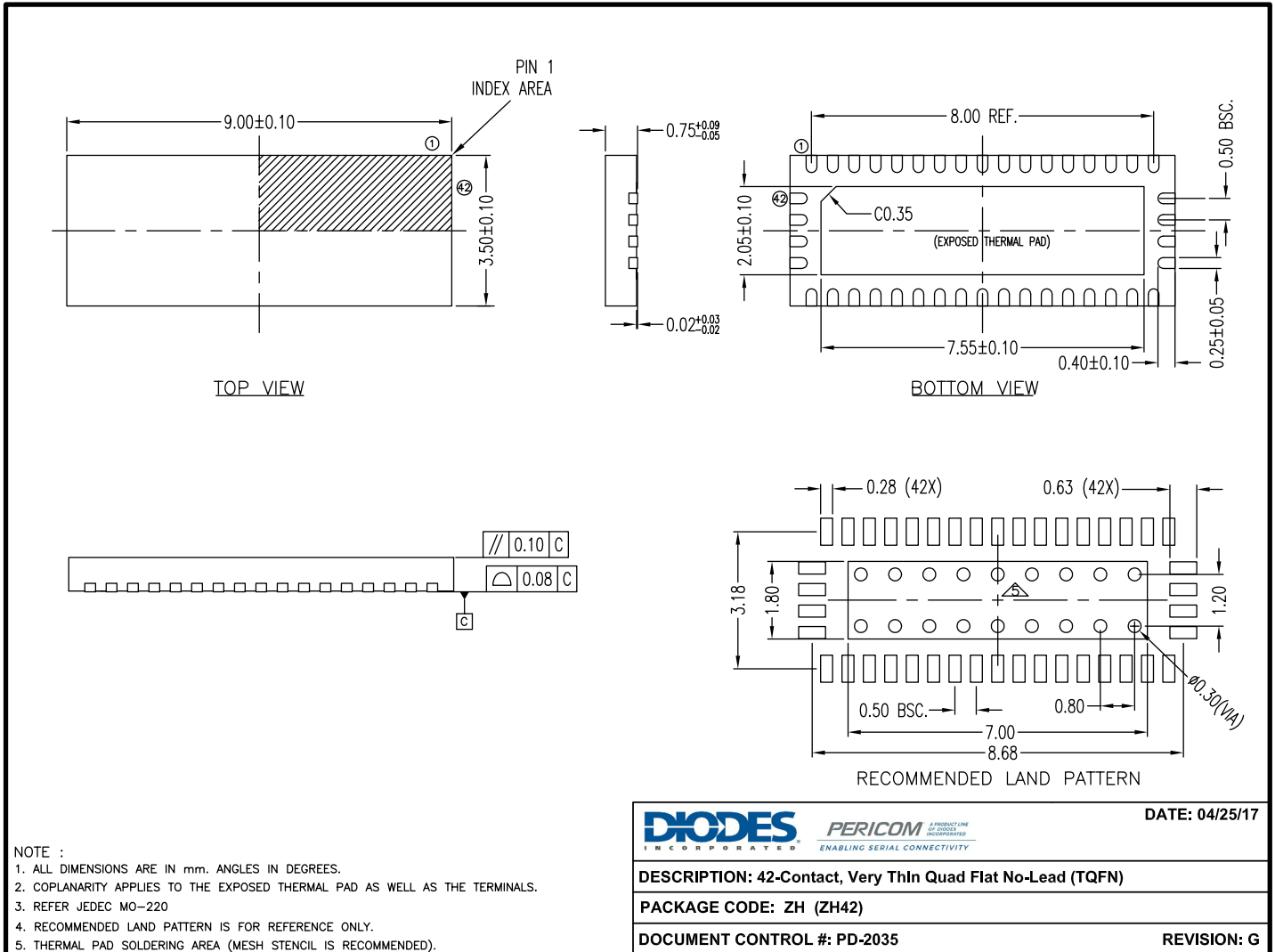

17-0266

For latest package information:

See <http://www.diodes.com/design/support/packaging/pericom-packaging/packaging-mechanicals-and-thermal-characteristics/>.

Ordering Information

Ordering Code	Package Code	Package Description
PI3PCIE3415AZHEX	ZH	42-contact, Very Thin Quad Flat No-Lead (TQFN), (width 24mm)
PI3PCIE3415AZHE+DRX	ZH	42-contact, Very Thin Quad Flat No-Lead (TQFN), (width 16mm)

Notes:

1. No purposely added lead. Fully EU Directive 2002/95/EC (RoHS), 2011/65/EU (RoHS 2) & 2015/863/EU (RoHS 3) compliant.
2. See <https://www.diodes.com/quality/lead-free/> for more information about Diodes Incorporated's definitions of Halogen- and Antimony-free, "Green" and Lead-free.
3. Halogen- and Antimony-free "Green" products are defined as those which contain <900ppm bromine, <900ppm chlorine (<1500ppm total Br + Cl) and <1000ppm antimony compounds.
4. E = Pb-free and Green
5. X suffix = Tape/Reel

IMPORTANT NOTICE

DIODES INCORPORATED MAKES NO WARRANTY OF ANY KIND, EXPRESS OR IMPLIED, WITH REGARDS TO THIS DOCUMENT, INCLUDING, BUT NOT LIMITED TO, THE IMPLIED WARRANTIES OF MERCHANTABILITY AND FITNESS FOR A PARTICULAR PURPOSE (AND THEIR EQUIVALENTS UNDER THE LAWS OF ANY JURISDICTION).

Diodes Incorporated and its subsidiaries reserve the right to make modifications, enhancements, improvements, corrections or other changes without further notice to this document and any product described herein. Diodes Incorporated does not assume any liability arising out of the application or use of this document or any product described herein; neither does Diodes Incorporated convey any license under its patent or trademark rights, nor the rights of others. Any Customer or user of this document or products described herein in such applications shall assume all risks of such use and will agree to hold Diodes Incorporated and all the companies whose products are represented on Diodes Incorporated website, harmless against all damages.

Diodes Incorporated does not warrant or accept any liability whatsoever in respect of any products purchased through unauthorized sales channel.

Should Customers purchase or use Diodes Incorporated products for any unintended or unauthorized application, Customers shall indemnify and hold Diodes Incorporated and its representatives harmless against all claims, damages, expenses, and attorney fees arising out of, directly or indirectly, any claim of personal injury or death associated with such unintended or unauthorized application.

Products described herein may be covered by one or more United States, international or foreign patents pending. Product names and markings noted herein may also be covered by one or more United States, international or foreign trademarks.

This document is written in English but may be translated into multiple languages for reference. Only the English version of this document is the final and definitive format released by Diodes Incorporated.

LIFE SUPPORT

Diodes Incorporated products are specifically not authorized for use as critical components in life support devices or systems without the express written approval of the Chief Executive Officer of Diodes Incorporated. As used herein:

A. Life support devices or systems are devices or systems which:

1. are intended to implant into the body, or

2. support or sustain life and whose failure to perform when properly used in accordance with instructions for use provided in the labeling can be reasonably expected to result in significant injury to the user.

B. A critical component is any component in a life support device or system whose failure to perform can be reasonably expected to cause the failure of the life support device or to affect its safety or effectiveness.

Customers represent that they have all necessary expertise in the safety and regulatory ramifications of their life support devices or systems, and acknowledge and agree that they are solely responsible for all legal, regulatory and safety-related requirements concerning their products and any use of Diodes Incorporated products in such safety-critical, life support devices or systems, notwithstanding any devices- or systems-related information or support that may be provided by Diodes Incorporated. Further, Customers must fully indemnify Diodes Incorporated and its representatives against any damages arising out of the use of Diodes Incorporated products in such safety-critical, life support devices or systems.

Copyright © 2019, Diodes Incorporated

www.diodes.com

X-ON Electronics

Largest Supplier of Electrical and Electronic Components

Click to view similar products for [Encoders, Decoders, Multiplexers & Demultiplexers](#) *category:*

Click to view products by [Diodes Incorporated](#) *manufacturer:*

Other Similar products are found below :

[MC74HC163ADTG](#) [74HC253N](#) [NLV74VHC1G01DFT1G](#) [NLVHC4851ADTR2G](#) [TC74AC138P\(F\)](#) [NLV14051BDR2G](#)
[NLV74HC238ADTR2G](#) [COMX-CAR-210](#) [5962-8607001EA](#) [5962-8756601EA](#) [SN74LS148N](#) [8CA3052APGGI8](#) [TC74HC4051AF\(EL,F\)](#)
[TC74VHC138F\(EL,K,F\)](#) [PI3B3251LE](#) [PI3B3251QE](#) [NLV74HC4851AMNTWG](#) [MC74LVX257DG](#) [M74HCT4851ADWR2G](#)
[MC74LVX257DTR2G](#) [74VHC4066AFT\(BJ\)](#) [74VHCT138AFT\(BJ\)](#) [74HC158D.652](#) [74HC4052D\(BJ\)](#) [74VHC138MTC](#) [COMX-CAR-P1](#)
[JM38510/65852BEA](#) [JM38510/30702BEA](#) [74VHC138MTCX](#) [74HC138D\(BJ\)](#) [NL7SZ19DFT2G](#) [74AHCT138T16-13](#) [74LCX138FT\(AJ\)](#)
[74LCX157FT\(AJ\)](#) [NL7SZ18MUR2G](#) [PCA9540BD,118](#) [SNJ54HC251J](#) [SN54LS139AJ](#) [SN74CBTLV3257PWG4](#) [SN74ALS156DR](#)
[SN74AHCT139PWR](#) [74HC251D.652](#) [74HC257D.652](#) [74HCT153D.652](#) [74HC253D.652](#) [74HCT139D.652](#) [TC74HC4052AFT\(EL\)](#)
[SN74LVC257AMPWREP](#) [74HC138DB.112](#) [74HC157PW.112](#)