

3.3V, USB3.0/DP1.2 6:4 Matrix Switch

Features

- 6 Differential Channel to 2/4 Differential Channel Matrix Switch
- USB 3.0 5Gb/s Super Speed and DP 1.2 5.4Gb/s switching to USB Type C connector
- Supports either pin control or I²C control to configure the mux
- Low insertion loss: -1.2dB @ 5Gb/s
- Return loss: -21dB @ 5Gb/s
- -3dB Bandwidth : 6GHz
- Multiplexes one of the following to USB Type C connector:
 - USB3.0 signal only
 - One lane of USB3.0 signal and 2 channels of DP1.2 or 4 channels of DP1.2 signal.
- With DP1.2 operating, AUX+ and AUX- are muxed to SBU pins. Max swing on SBU pins are from -0.35V to 3.95V
- 3.0V to 3.6V Power Supply.
- Industrial Temperature Range: -40°C to 85°C
- Packaging (Pb-free & Green):
 - 40- contact, TQFN(3 x6mm)

Pin Configuration (40 pin TQFN)

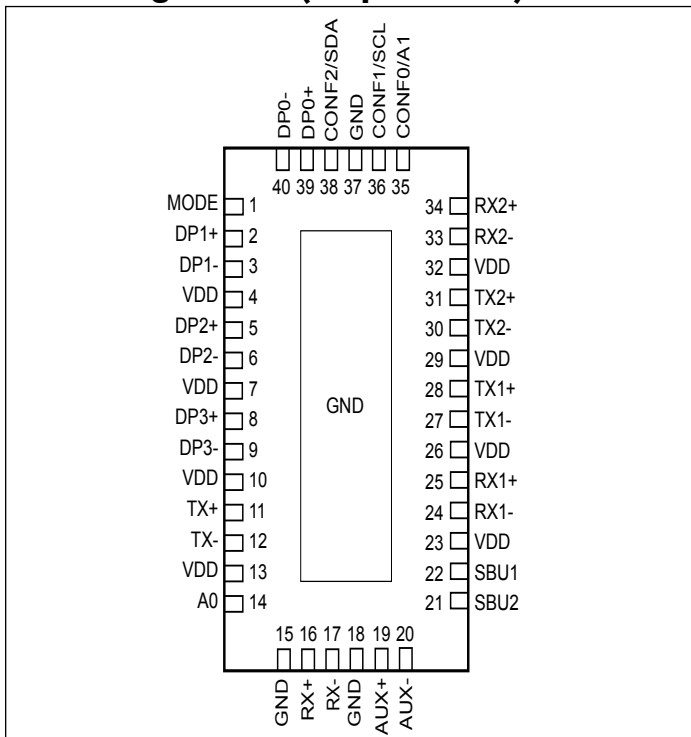

Description

Pericom Semiconductor's PI3USB30532 is a 6:4 differential channel bi-directional matrix switch solution for switching USB3.0 and/or DP1.2 signals through USB3.0 Type-C connector.

It multiplexes either 1 lane of USB3.0, 1 lane of USB3.0 and 2 channels of DP1.2 or 4 channels of DP1.2 to the USB Type C connector. In addition, AUXHPD channels are also multiplexed to the Type C connector. PI3USB30532 offers excellent signal integrity for high-speed signals and low power dissipation. Insertion loss is -1.2dB and return loss is -21dB at 5Gb/s speed of USB3.0.

Application

- Routing USB3.0 SuperSpeed and DP1.2 signals through the USB Type C Connector.
- Applications include Ultrabook, 2 in 1 Notebook, Tablet, Mobile Workstation, All In One PC, Monitor, Docking Station, Phone

Block Diagram

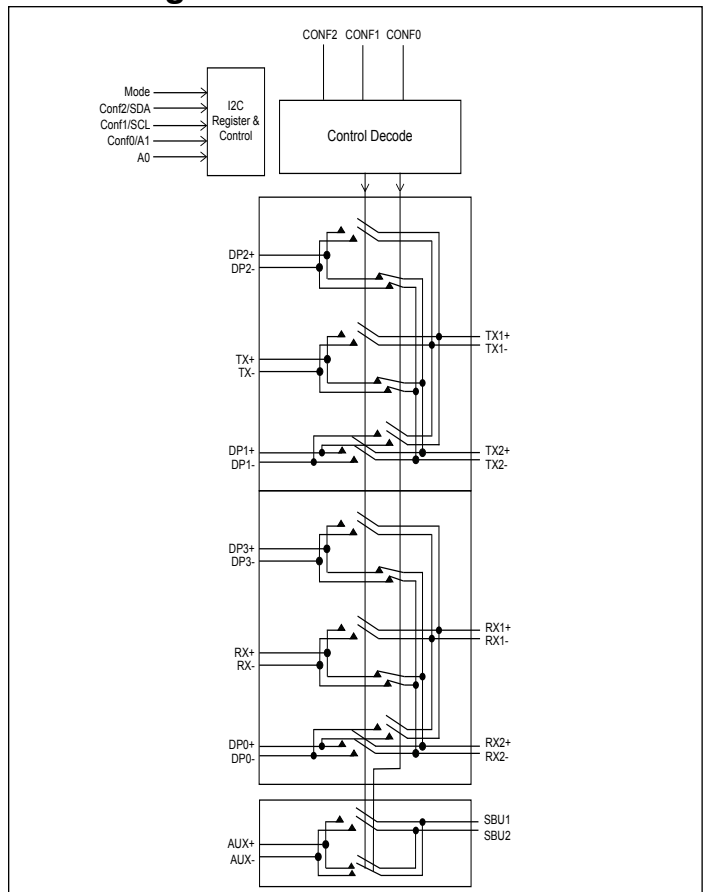

Pin Description

Pin#	Pin Name	Type	Description
4, 7, 10, 13, 23, 26, 29, 32	VDD	Power	3.0V - 3.6V power supply.
11, 12	TX+, TX-	I/O	Differential USB3.0 Transmit signal. Connected internally with 100Kohm pull-down to ground.
16, 17	RX+, RX-	I/O	Differential USB3.0 Receive signal. Connected internally with 100Kohm pulldown to ground.
39, 40	DP0+, DP0-	I/O	Differential DP0 signal. Connected internally with 100Kohm pulldown to ground.
2, 3	DP1+, DP1-	I/O	Differential DP1 signal. Connected internally with 100Kohm pulldown to ground.
5, 6	DP2+, DP2-	I/O	Differential DP2 signal. Connected internally with 100Kohm pulldown to ground.
8, 9	DP3+, DP3-	I/O	Differential DP3 signal. Connected internally with 100Kohm pulldown to ground.
19, 20	AUX+, AUX-	I/O	Differential Auxiliary signal for DP.
22, 21	SBU1, SBU2	I/O	Side Band signal at Type C connector.
25, 24	RX1+, RX1-	I/O	Differential Receive signal 1 at Type C connector.
28, 27	TX1+, TX1-	I/O	Differential Transmit signal 1 at Type C connector.
31, 30	TX2+, TX2-	I/O	Differential Transmit signal 2 at Type C connector.
34, 33	RX2+, RX2-	I/O	Differential Receive signal 2 at Type C connector.
1	MODE	I	Control mode selection MODE = 1, I2C control = 0, pin control through CONF[2:0]
35, 36, 38	CONF[2:0]	I	Switch configuration selection pin when MODE = 0, please refer to 'switch selection truth tanle' for detail, When MODE = 1, these pins are part of the I2C interface as SDA/SCL/A1.
38	SDA	I/O	Serial in data of I2C when MODE = 1.
36	SCL	I	I2C clock input pin when MODE = 1.
35	A1	I	A[1] of A[1:0] I2C selectable address when MODE = 1.
14	A0	I	A[0] of A[1:0] I2C selectable address when MODE = 1.
15, 18, 37, Center Pad	GND	Power	Ground supply.

Configuration Table

Switch	Open	Open	4 lane of DP1.2	4 lane of DP1.2 Swap	USB3	USB3 Swap	USB3 +2 lane of DP1.2	USB3 +2 lane of DP1.2 Swap
Conf[2:0]	000	001	010	011	100	101	110	111
TX	x	x	x	x	TX1	TX2	TX1	TX2
RX	x	x	x	x	RX1	RX2	RX1	RX2
DP0	x	x	RX2	RX1	x	x	RX2	RX1
DP1	x	x	TX2	TX1	x	x	TX2	TX1
DP2	x	x	TX1	TX2	x	x	x	x
DP3	x	x	RX1	RX2	x	x	x	x
AUX+	x	x	SBU1	SBU2	x	x	SBU1	SBU2
AUX-	x	x	SBU2	SBU1	x	x	SBU2	SBU1

000 = switch open with power down

001 = switch open only, no power down

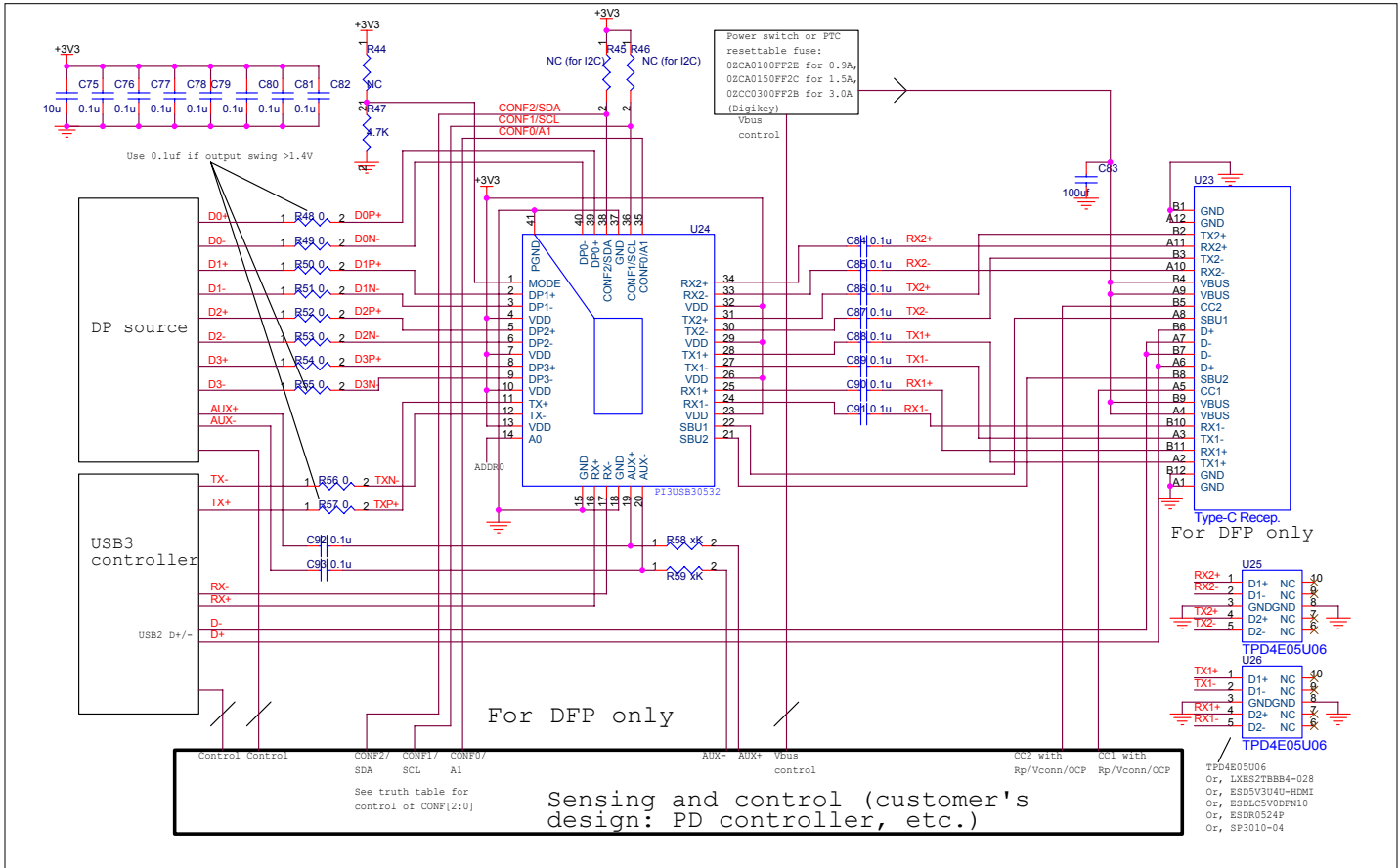

PI3USB30532 Application Diagram

Maximum Ratings

(Above which useful life may be impaired. For user guidelines, not tested.)

Supply Voltage to Ground Potential, $V_{DD} = 3.3V$	-0.3V to 4.3V
Control DC input.....	-0.3V to $V_{DD}+0.3V$
Ambient Operating Temperature	-40 to +85°C
Storage Temperature.....	-65 to +150°C
Junction Temperature	150°C
Soldering Temperature.....	260°C
Channel DC input for USB, DP	-0.3V to 1.2V
Channel DC input for AUX.....	-0.35V to V_{DD}

Note: Stresses greater than those listed under MAXIMUM RATINGS may cause permanent damage to the device. This is a stress rating only and functional operation of the device at these or any other conditions above those indicated in the operational sections of this specification is not implied. Exposure to absolute maximum rating conditions for extended periods may affect reliability.

Recommended Operation Conditions

Parameter	Min.	Typ.	Max.	Unit
Ambient Operating Temperature	-40		+85	°C
Power Supply Voltage (measured in respect to GND)	3.0	3.3	3.6	V

Static Characteristics

Symbol	Parameter	Conditions	Min.	Typ.	Max.	Unit
V_{DD}	Supply Voltage		3.0	3.3	3.6	V
I_{DD}	VDD Supply Current	$V_{DD} = 3.3V$ all Conf[2:0] states except [000]		300	350	μA
		$V_{DD} = 3.3V$ Conf[2:0] = 000		10	30	μA
I_{OFF}	I/O leakage when power is off	$V_{DD} = 0V$ $V_{IO}(usb3) = 0V$ $V_{IO}(dp1.2) = 0V$ $V_{IO}(aux) = 0V$ $V_{IO}(sbu) = 0V$			50	nA

Control/I2C pin (MODE, A0, A1, SDA, SCL)

I_{IH}	High level digital input current	$V_{IH} = V_{DD}$ $V_{DD} = 3.6V$			5	μA
I_{IL}	Low level digital input current	$V_{IL} = GND$ $V_{DD} = 3.6V$			5	μA
V_{IH}	High level digital input voltage	$V_{DD} = 3.0V-3.6V$	0.75 * V_{DD}			V
V_{IL}	Low level digital input voltage	$V_{DD} = 3.0V-3.6V$			0.6	V

Control pin (CONF [2:0])

I_{IH}	High level digital input current	$V_{IH} = V_{DD}$ $V_{DD} = 3.6V$			5	μA
----------	----------------------------------	--------------------------------------	--	--	---	---------

Symbol	Parameter	Conditions	Min.	Typ.	Max.	Unit
I _{IL}	Low level digital input current	V _{IL} = GND V _{DD} = 3.6V			5	μA
V _{IH}	High level digital input voltage	V _{DD} = 3.0V-3.6V	1.2			V
V _{IL}	Low level digital input voltage	V _{DD} = 3.0V-3.6V			0.4	V
I/O pin (TX+, TX-, RX+, RX-, TX1+, TX1-, RX1+, RX1-, TX2+, TX2-, RX2+, RX2-DP0+, DP0-, DP1+, DP1-, DP2+, DP2-, DP3+, DP3-) (AUX+, AUX-, SBU1, SBU2)						
C _{OFF}	USB3/DP1.2 switch OFF capacitance	V _{IO} = GND f = 1MHz		1.2		pF
C _{ON}	USB3/DP1.2 switch ON capacitance	V _{IO} = GND f = 1MHz		2.3		pF
C _{OFF}	AUX+/AUX- switch OFF capacitance	V _{IO} = GND f = 1MHz		4.0		pF
C _{ON}	AUX+/AUX- switch ON capacitance	V _{IO} = GND f = 1MHz		7.0		pF
I _{OZL}	I/O leakage for TX_to_TX1/TX2, RX_to_RX1/RX2 DP _x _to_TX/RX(x = 0, 1, 2, 3) AUX_to_SBU _y (y = 1, 2)	V _{DD} = 3.6V, V _{IO} (usb3) = 0V, V _{IO} (dp1.2) = 0V, V _{IO} (aux) = 0V		1	5	μA
I _{OZH}	I/O leakage for TX_to_TX1/TX2, RX_to_RX1/RX2 DP _x _to_TX/RX(x = 0, 1, 2, 3) AUX_to_SBU _y (y = 1, 2)	V _{DD} = 3.6V, V _{IO} (usb3) = 1.2V, V _{IO} (dp1.2) = 1.2V, V _{IO} (aux) = 4.0V		1	15	μA
Linear region for Analog switch						
V _{p_IO}	Linear region for analog switch TX_to_TX1/TX2, RX_to_RX1/RX2 DP _x _to_TX/RX(x = 0, 1, 2, 3)	V _{DD} = 3.3V, I _{pass} = 10mA	1.4	1.6		V
V _{p_IOSB}	Linear region for analog switch AUX_to_SBU _x (x = 1, 2)	V _{DD} = 3.3V, I _{pass} = 10mA	4.0	4.2		V

Dynamic Characteristics

Min and Max apply for T_A between -40°C to 85°C Typical values are referenced to $T_A = 25^{\circ}\text{C}$

Symbol	Parameter	Test Conditions	Min.	Typ.	Max.	Units
tstartup	Startup time	Supply voltage valid or (*) the device is powered up & channel is turn on to its specified characteristics VDD = 3V		10	20	μs
trcfg	Reconfiguration time	Conf[2:0] change to channel specified operating characteristics		1	2	
tpd	Propagation delay 1	From input port to output port USB/DP		80		ps
tpd	Propagation delay 2	From input port to output port AUX		150		ps
tsk	Skew time 1	From input port to output USB/DP Bit to bit skew		10		ps
tsk	Skew time 2	From input port to output AUX Bit to bit skew		20		ps
VI_sub_dp	USB/DP input signal	USB/DP switch analog signal	-0.3		1.2	V
VI_aux	AUX+/AUX- input signal	AUX switch analog signal	-0.35		VDD	V

* Conf[2:0] changes from [000] to [001]/[010]/[011]/[100]/[101]/[110]/[111]

Switch AC Electrical Characteristics

Min and Max apply for T_A between -40°C to 85°C and T_J up to $+125^{\circ}\text{C}$ (unless otherwise noted). Typical values are referenced to $T_A = +25^{\circ}\text{C}$, $V_{DD} = 3.3\text{V}$

Symbol	Parameter	Frequency/Vcom	Typ.	Units	
BW_usb	-3dB bandwidth of USB3	-	6.0	GHz	
I _L	Differential Insertion Loss	2.5/2.7GHz/0V	-1.2/-1.3	dB	
R _L	Differential Return Loss	2.5/2.7GHz/0V	-21/ -20	dB	
Xtalk	Differential Crosstalk	2.5/2.7GHz/0V	USB	-38/-37	dB
			DP	-25/-24	
Xoff	Off Isolation	2.5/2.7GHz/0V	-23/-22	dB	

I²C AC Electrical Characteristics

Symbol	Parameter	Fast Mode (400kHz)		Units
		Min.	Max.	
f _{SCL}	SCL Clock Frequency	0	400	kHz
t _{HDSTA}	Hold Time (Repeated) START Condition	0.6	-	μs
t _{LOW}	LOW Period of SCL Clock	1.3	-	μs
t _{HIGH}	HIGH Period of SCL Clock	0.6	-	μs
t _{SETSTA}	Set-up Time for Repeated START Condition	0.6	-	μs
t _{HDDAT}	Data Hold Time	0	0.9	μs
t _{SETDAT}	Data Set-up Time	100	-	μs
t _r	Rise Time of SDA and SCL Signals	20+0.1C _b	300	ns
t _f	Fall Time of SDA and SCL Signals	20+0.1C _b	300	
t _{SETSTO}	Set-up Time for STOP Condition	0.6	-	μs

I2C Control

** I2C function reference:

" THE I2C-BUS SPECIFICATION, VERSION 2.1"

I2C Control register:

	Register Bits							
	Bit7	Bit6	Bit5	Bit4	Bit3	Bit2	Bit1	Bit0
Slave address (First byte is slave address)	1	0	1	0	1	A1	A0	0/1 (W/R)
Vendor ID (Second byte is vendor ID, read only)	0	0	0	0	0	0	0	0
Selection control (Third byte is for selection control, read/write)	0	0	0	0	0	conf[2]	conf[1]	conf[0]

Note:

1. Bit7 - Bit3 = Version ID (00000) in (01H)
2. Bit2 - Bit0 = Pericom Vendor ID (000) in (01H)
3. A0, A1 are hardware selectable (pin35, pin36)
4. conf[2]/conf[1]/conf[0] are written into the register by the master PI3USB30532 will decode Bit2 - Bit0 in (02h) for I2C control (Pin1/MODE = 1). Default power-up state is 000.

Bus Transactions

Data transfers follow the format shown in Fig.A1 After the START condition (S), a slave address is sent. This address is 7 bits long followed by an eighth bit which is a data direction bit (R/W) - a 'zero' indicates a transmission (WRITE), a 'one' indicates a request for data (READ). A data transfer is always terminated by a STOP condition (P) generate by the master. However, if a master still wishes to communicate on the bus, it can generate a repeated START condition (S) and address another slave without first generating a STOP condition. Various combinations of read/write formats are then possible within such a transfer.

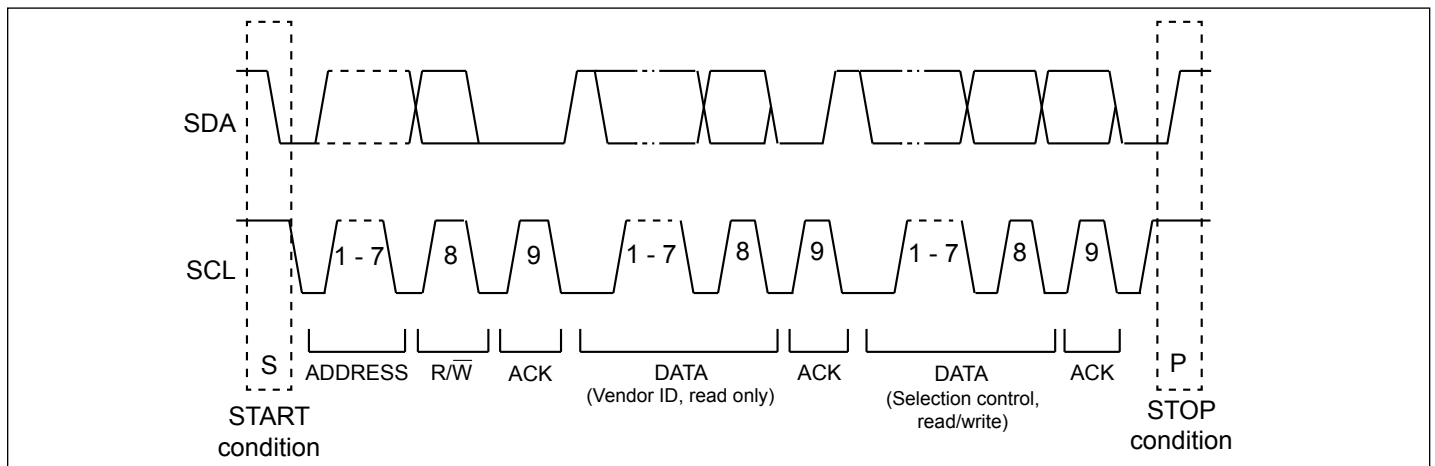

Figure A1: A Complete Data Transfer

Data is transmitted to the PI3USB30532 registers using the Write mode as shown in Figure 2. Data is read from the PI3USB30532 registers using the Read mode as shown in Figure A2.

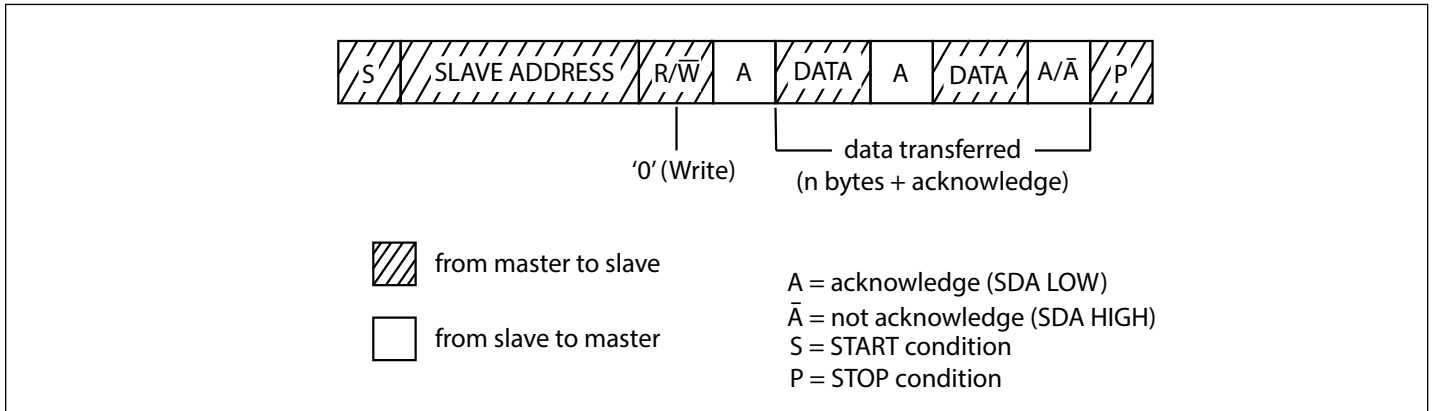

Figure 2: Write to Control Register

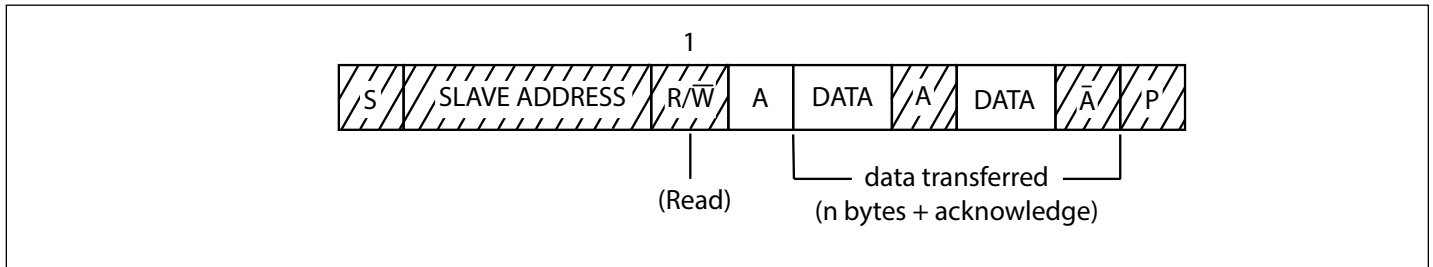
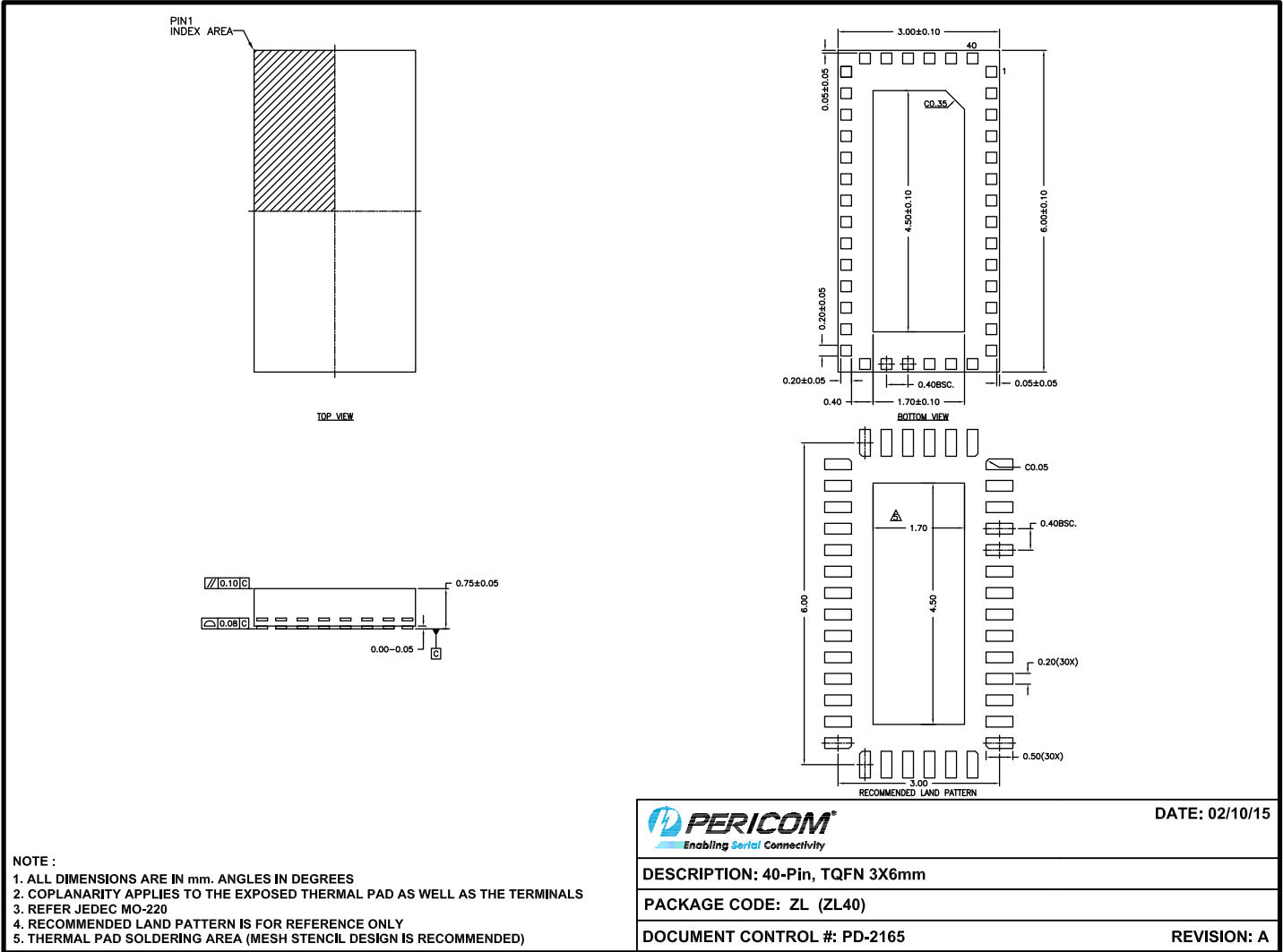

Figure A2: Read to Control Register

Packaging Mechanical: 40-Pin TQFN



Note: For latest package info, please check: <http://www.pericom.com/support/packaging/packaging-mechanicals-and-thermal-characteristics/>

Ordering Information

Ordering Code	Packaging Code	Package Description
PI3USB30532ZLE	ZL	40-contact, 3x6mm (TQFN)

NOTES:

1. Thermal characteristics can be found on the company web site at www.pericom.com/package
2. E = Pb-free and Green
3. Adding an X suffix = Tape/Reel

X-ON Electronics

Largest Supplier of Electrical and Electronic Components

Click to view similar products for [USB Switch ICs category](#):

Click to view products by [Diodes Incorporated manufacturer](#):

Other Similar products are found below :

[NLAS7213MUTBG](#) [FSA221UMX](#) [FSUSB31UMX](#) [FSA806UMX](#) [NL3S2223MUTBG](#) [TC7USB3212WBG\(ELAH](#) [PI3USB31531ZLCEX](#)
[PI5USB31213XEAEX](#) [BD91N01NUX-E2](#) [MP5030DGQH-Z](#) [NL3S22AHMUTAG](#) [NL3S22UHMUTAG](#) [FSA9280AUMX](#)
[NLAS7242MUTBG](#) [TPS2549IRTERQ1](#) [PI2USB4122ZHEX](#) [TS5USBC402IYFPT](#) [NS5S1153MUTAG](#) [FSUSB11MTCX](#) [FT234XD-R](#)
[PI3USB102GZLEX](#) [P6KE110A](#) [SMAJ200A](#) [SMAJ70CA](#) [SMAJ11A](#) [SMAJ140CA](#) [SMAJ14A](#) [SMAJ160CA](#) [SMAJ250A](#) [SMAJ51CA](#)
[SMAJ5.0CA](#) [30KP400CA](#) [1SMB5.0AT3G](#) [MAX4989ETD+T](#) [MAX4717EBCT](#) [MAX4717EUB+](#) [MAX4906ELB+T](#) [MAX4906EFELB+T](#)
[MAX4906FELB+T](#) [MAX4983EEVB+T](#) [MAX4899AEETE+T](#) [MAX14651ETA+T](#) [PI3USB20LE](#) [UCS2114-1-V/LX](#) [UCS2113-1-V/G4](#)
[UCS2113T-1-V/G4](#) [UCS2112-1-V/G4](#) [FSA1153UCX](#) [FSA221L10X](#) [FSA221MUX](#)