

PI3WVR626

2:1 MIPI 2-Data Lane Switch

Features

- 3-lane, 2:1 switches that support D-PHY and C-PHY
- Data rate support: up to 2.5Gbps C-PHY, up to 3Gb/s D-PHY.
- Bandwidth: 4.5 GHz Typical
- Low Crosstalk: -35 dB@1.25 GHz
- Input Signals 0 to 1.3V
- RON: 5.0Ω Typical LP & HS MIPI
- ΔR_{ON} : 0.2Ω Typical LP & HS MIPI
- R_{ON_FLAT} : 0.1Ω Typical LP & HS MIPI
- I_{CC} : 11μA Typical
- Skew of Opposite Transitions of the Same Output: 5ps Typical
- V_{DD} Operating Range: 1.5V to 3.6V
- ESD Tolerance: 2kV HBM
- Totally Lead-Free & Fully RoHS Compliant (Notes 1 & 2)
- Halogen and Antimony Free. "Green" Device (Note 3)
- For automotive applications requiring specific change control (i.e. parts qualified to AEC-Q100/101/200, PPAP capable, and manufactured in IATF 16949 certified facilities), please [contact us](#) or your local Diodes representative.
<https://www.diodes.com/quality/product-definitions/>
- Packaging (Pb-free & Green):
 - 24-Pin, X1QFN (2.5mm x 2.5mm) (XEB)

Description

Diodes' PI3WVR626 is a two-data-lane MIPI switch. This 6 channel single-pole, double-throw (SPDT) switch is optimized for switching between two high-speed (HS) or low-power (LP) MIPI signal. The PI3WVR626 is designed for the MIPI specification and allows connection to CSI/DSI, C-PHY/D-PHY module.

Applications

- Cellular Phones, Smart Phone
- Tablets
- Laptops
- Displays

Notes:

1. No purposely added lead. Fully EU Directive 2002/95/EC (RoHS), 2011/65/EU (RoHS 2) & 2015/863/EU (RoHS 3) compliant.
2. See <https://www.diodes.com/quality/lead-free/> for more information about Diodes Incorporated's definitions of Halogen- and Antimony-free, "Green" and Lead-free.
3. Halogen- and Antimony-free "Green" products are defined as those which contain <900ppm bromine, <900ppm chlorine (<1500ppm total Br + Cl) and <1000ppm antimony compounds.

PI3WVR626

Block Diagram

PI3WVR626 D-PHY Application

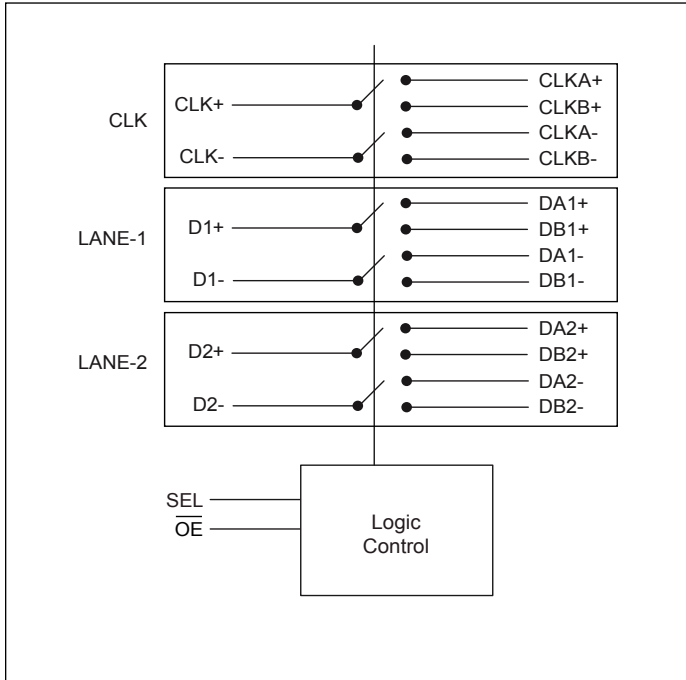

PI3WVR626 C-PHY Application

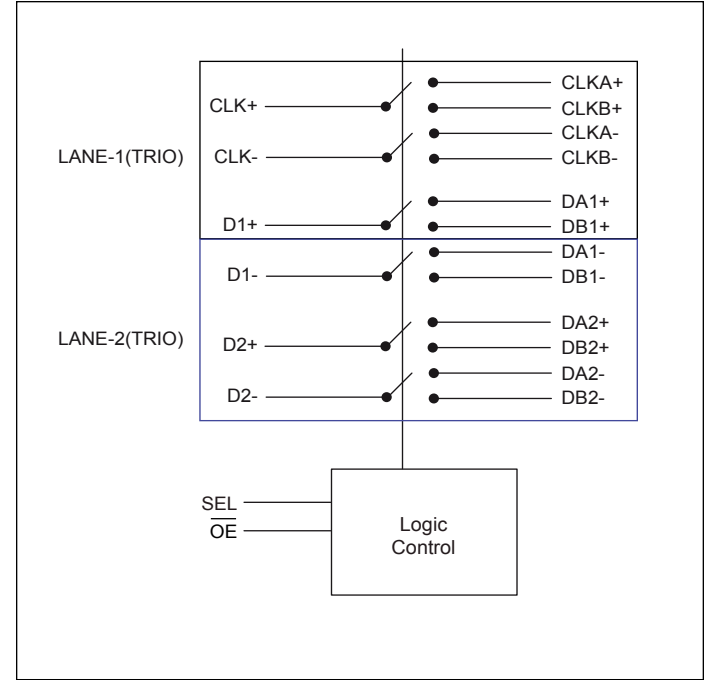

PI3WVR626

Pin Configuration(Top View)

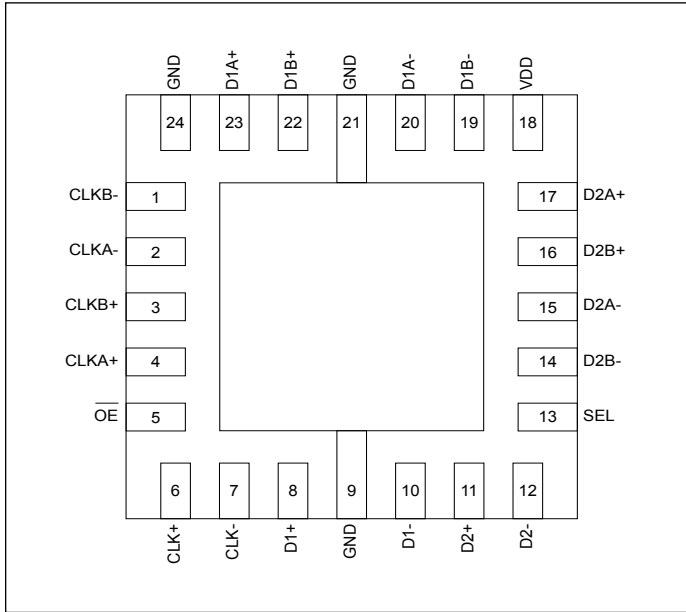

Block Diagram

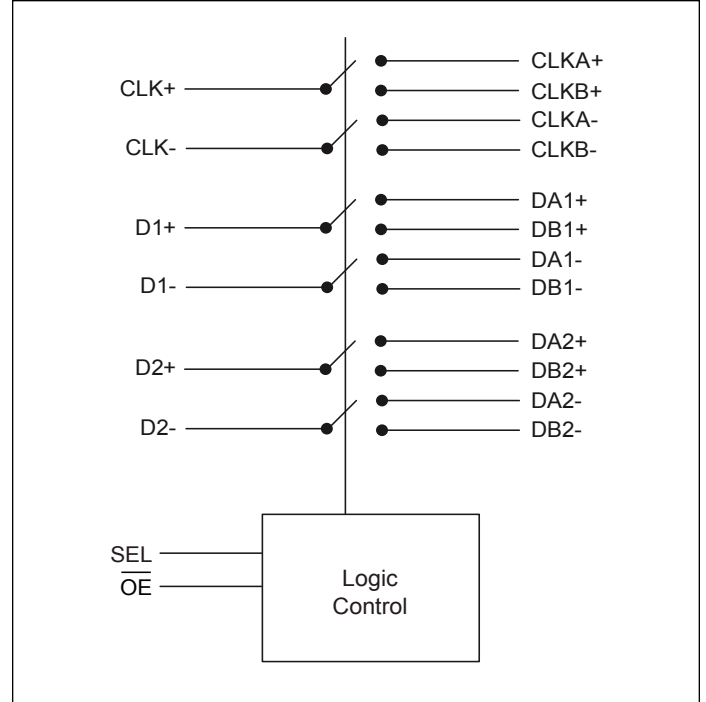

Truth Table

SEL	$\overline{\text{OE}}$	Function
LOW	LOW	CLK+ = CLKA+, CLK- = CLKA-, Dn(+/-) = DAn(+/-)
HIGH	LOW	CLK+ = CLKB+, CLK- = CLKB-, Dn(+/-) = DBn(+/-)
X	HIGH	Clock and Data Ports High Impedance

Pin Description

Pin#	Pin Name	Signal Type	Description
18	V _{DD}	Power	1.5V to 3.3V power supply
9, 21, 24	GND	Ground	Ground
5	$\overline{\text{OE}}$	I	Output enable. if OE is low, IC is enabled. if OE is high, IC is power down and all I/Os are Hi-Z
13	SEL	I	Switch logic control
14	D2B-	I/O	Negative differential signal 2 for port B
16	D2B+	I/O	Positive differential signal 2 for port B
15	D2A-	I/O	Negative differential signal 2 for port A
17	D2A+	I/O	Positive differential signal 2 for port A
12	D2-	I/O	Negative differential signal 2 for COM port
11	D2+	I/O	Positive differential signal 2 for COM port
19	D1B-	I/O	Negative differential signal 1 for port B
22	D1B+	I/O	Positive differential signal 1 for port B
20	D1A-	I/O	Negative differential signal 1 for port A
23	D1A+	I/O	Positive differential signal 1 for port A
10	D1-	I/O	Negative differential signal 1 for COM port
8	D1+	I/O	Positive differential signal 1 for COM port
1	CLKB-	I/O	Clock negative differential signal for port B
3	CLKB+	I/O	Clock positive differential signal for port B
2	CLKA-	I/O	Clock negative differential signal for port A
4	CLKA+	I/O	Clock positive differential signal for port A
7	CLK-	I/O	Clock negative differential signal for COM port
6	CLK+	I/O	Clock positive differential signal for COM port

Absolute Maximum Ratings

(Above which useful life may be impaired. For user guidelines, not tested.)

V _{CC} , Supply Voltage,	-0.5V to 4.5V
V _{CNTRL} , DC Input Voltage (\overline{OE} , SEL) ⁽¹⁾	-0.5V to V _{CC}
V _{SW} , DC Switch I/O Voltage ^(1,2)	-0.3V to 2.5V
I _{IK} , DC Input Diodes Current	-50mA
I _{OUT} , DC Output Current	25mA
T _{STG} , Storage Temperature	-65°C to +150°C
T _j , Junction Temperature.....	125°C
ESD:	
Human Body Model, JEDEC: JESD22-A114, All Pins.....	2.0kV
Charged Device Model, JEDEC: JESD22-C101.....	1.0kV

Note:

Stresses greater than those listed under MAXIMUM RATINGS may cause permanent damage to the device. This is a stress rating only and functional operation of the device at these or any other conditions above those indicated in the operational sections of this specification is not implied. Exposure to absolute maximum rating conditions for extended periods may affect reliability.

Note:

1. The input and output negative ratings may be exceeded if the input and output diode current ratings are observed.
2. V_{SW} refers to analog data switch paths.

Recommended Operating Conditions

The Recommended operating Conditions table defines the conditions for actual device operation. Recommended operating conditions are specified to ensure optimal performance to the datasheet specifications.

Symbol	Description	Test Conditions	Min.	Max.	Units
V _{CC}	Supply Voltage		1.5	3.6	V
V _{CNTRL}	Control Input Voltage (SEL, \overline{OE}) ⁽¹⁾		0	V _{CC}	V
V _{SW}	Switch I/O Voltage (CLK-, D-, CLKA-, CLKB-, DA-, DB-)	- HS Mode	0	0.5	V
		- LP Mode	0	1.3	V
T _A	Operating Temperature		-40	+85	°C

Note:

1. The control inputs must be held HIGH or LOW; they must not float.

DC and Transient Characteristics

All typical values are at T_A = 25°C unless otherwise specified.

Symbol	Description	Test Conditions	V _{CC} (V)	T _A = -40°C to +85°C			Units
				Min.	Typ.	Max.	
V _{IK}	Clamp Diode Voltage (\overline{OE} , SEL)	I _{IN} = -18mA	1.5	-1.2		-0.6	V
V _{IH}	Input Voltage High	SEL, \overline{OE}	1.5 to 3.3	-1.0			V
V _{IL}	Input Voltage Low	SEL, \overline{OE}	1.5 to 3.3			0.5	V
I _{IN}	Control Input Leakage (\overline{OE} , SEL)	V _{CNTRL} = 0 to V _{CC}	3.3	-1.0		1.0	μA
I _{NO(OFF)} I _{NC(OFF)}	Off Leakage Current of Port CLKA-, DA-, CLKB- and DB-	V _{SW} = 0.0 ≤ DATA ≤ 1.3V	3.3	-1.0		1.0	μA
I _{A(ON)}	On Leakage Current of Common Ports (CLK-, D-)	V _{SW} = 0.0 ≤ DATA ≤ 1.3V	3.3	-1.0		1.0	μA

DC and Transient Characteristics Cont.

Symbol	Description	Test Conditions	V _{CC} (V)	T _A = -40°C to +85°C			Units
				Min.	Typ.	Max.	
I _{OFF}	Power-Off Leakage Current (All I/O Ports)	V _{SW} = 0.0 or 1.3V	0	-5		5.0	μA
I _{OZ}	Off-State Leakage	V _{SW} = 0.0 ≤ DATA ≤ 1.3V, OE = High	3.6	-5		5.0	μA
R _{ON_MIPI_HS}	Switch On Resistance for HS MIPI	I _{ON} = -8mA, OE = 0V, SEL = V _{CC} or 0V, CLKA, CLKB, DB- or DA- = 0.2V	1.5		5		Ω
			2.5				
			3.3				
R _{ON_MIPI_LP}	Switch On Resistance for LP MIPI	I _{ON} = -8mA, OE = 0V, SEL = V _{CC} or 0V, CLKA, CLKB, DB- or DA- = 1.2V	1.5		5		Ω
			2.5				
			3.3				
ΔR _{ON_MIPI_HS}	On Resistance Matching Between HS MIPI Channels ⁽¹⁾	I _{ON} = -8mA, OE = 0V, SEL = V _{CC} or 0V, CLKA, CLKB, DB- or DA- = 0.2V	1.5		0.2		Ω
			2.5				
			3.3				
ΔR _{ON_MIPI_LP}	On Resistance Matching Between LP MIPI Channels ⁽¹⁾	I _{ON} = -8mA, OE = 0V, SEL = V _{CC} or 0V, CLKA, CLKB, DB- or DA- = 1.2V	1.5		0.2		Ω
			2.5				
			3.3				
R _{ON_FLAT_MIPI_HS}	On Resistance Flatness for HS MIPI	I _{ON} = -8mA, OE = 0V, SEL = V _{CC} or 0V, CLKA, CLKB, DB- or DA- = 0 to 0.5V	1.5		0.1		Ω
			2.5				
			3.3				
R _{ON_FLAT_MIPI_LP}	On Resistance Flatness for LP MIPI	I _{ON} = -8mA, OE = 0V, SEL = V _{CC} or 0V, CLKA, CLKB, DB- or DA- = 0 to 1.3V	1.5		0.1		Ω
			2.5				
			3.3				
I _{CC}	Quiescent Supply Current	V _{SEL} = 0 or V _{CC} , I _{OUT} = 0, OE = 0V	3.6		11	20	μA
I _{CCZ}	Quiescent Supply Current (High Impedance)	V _{SEL} = 0 or V _{CC} , I _{OUT} = 0, OE = 0V	3.6			1	μA
I _{CCCT}	Increase in I _{CC} Current Per Control Voltage and V _{CC}	V _{SEL} = 0 or V _{CC} , OE = 1.5V	3.6		1		μA

AC Electrical Characteristics

All typical values are for $V_{CC} = 3.3V$ and $T_A = 25^\circ C$ unless otherwise specified.

Symbol	Description	Test Conditions	V_{CC} (V)	$T_A = -40^\circ C$ to $+85^\circ C$			Units
				Min.	Typ.	Max.	
t_{INIT}	Initialization Time V_{CC} to Output ⁽¹⁾	$R_L = 50\Omega$, $C_L = 0pF$, $V_{SW} = 0.6V$	1.5 to 3.6		60		μs
t_{EN}	Enable Time \overline{OE} to Output	$R_L = 50\Omega$, $C_L = 0pF$, $V_{SW} = 0.6V$	1.5 to 3.6		60	150	μs
t_{DIS}	Disable Time \overline{OE} to Output	$R_L = 50\Omega$, $C_L = 0pF$, $V_{SW} = 0.6V$	1.5 to 3.6		35	250	ns
t_{ON}	Turn-On Time SEL to Output	$R_L = 50\Omega$, $C_L = 0pF$, $V_{SW} = 0.6V$	1.5 to 3.6		350	1100	ns
t_{OFF}	Turn-Off Time SEL to Output	$R_L = 50\Omega$, $C_L = 0pF$, $V_{SW} = 0.6V$	1.5 to 3.6		125	800	ns
t_{BBM}	Break-Before-Make Time	$R_L = 50\Omega$, $C_L = 0pF$, $V_{SW} = 0.6V$	1.5 to 3.6			450	ns
t_{PD}	Propagation Delay ⁽¹⁾	$C_L = 0pF$, $R_L = 50\Omega$	1.5 to 3.6			0.25	ns
O_{IRR}	Off Isolation for MIPI ⁽¹⁾	$R_L = 50\Omega$, $f = 1250MHz$, $\overline{OE} = HIGH$, $V_{SW} = 0.5V$	1.5 to 3.6		-28		dB
X_{TALK}	Crosstalk for MIPI ⁽¹⁾	$R_L = 50\Omega$, $f = 1250MHz$, SEL = HIGH, $V_{SW} = 0.5V$	1.5 to 3.6		-35		dB
I_{LOSS}	Insertion Loss ⁽¹⁾	$R_L = 50\Omega$, $C_L = 0pF$, $f = 1250MHz$, $V_{SW} = 0.5V$	1.5 to 3.6		-0.7		dB
BW	-3db Bandwidth ⁽¹⁾	$R_L = 50\Omega$, $C_L = 0pF$, $V_{SW} = 0.5V$	1.5 to 3.6	4	4.5		GHz

Note:

1. Guaranteed by characterization.

High-Speed-Related AC Electrical Characteristics

Symbol	Description	Test Conditions	V _{CC} (V)	T _A = -40°C to +85°C			Units
				Min.	Typ.	Max.	
t _{SK(P)}	D-PHY HS Mode Skew of Opposite Transitions of the Same Output ⁽¹⁾	R _L = 50Ω, C _L = 0pF, V _{SW} = 0.3V	1.5 to 3.6		4	8	ps
	C-PHY HS Mode Skew of 3 channels in same lane	R _L = 50Ω, C _L = 0pF, V _{SW} = 0.5V	1.5 to 3.6		4		
	D-PHY HS Mode Skew of all group A or group B channels ⁽¹⁾	R _L = 50Ω, C _L = 0pF, V _{SW} = 0.3V	1.5 to 3.6		6	10	

Note:

1. Guaranteed by characterization.

Capacitance

Symbol	Description	Test Conditions	T _A = -40°C to +85°C			Units
			Min.	Typ.	Max.	
C _{IN}	Control Pin Input Capacitance ⁽¹⁾	V _{CC} = 0V, f = 1MHz		2.1		pF
C _{ON}	On Capacitance ⁽¹⁾	V _{CC} = 3.3V, \overline{OE} = 0V, f = 1250MHz (In HS common value)		1.3		pF
C _{OFF}	Off Capacitance ⁽¹⁾	V _{CC} or \overline{OE} = 3.3V, f = 1250MHz (Both sides in HS common value)		0.8		pF

Note:

1. Guaranteed by characterization.

PI3WVR626

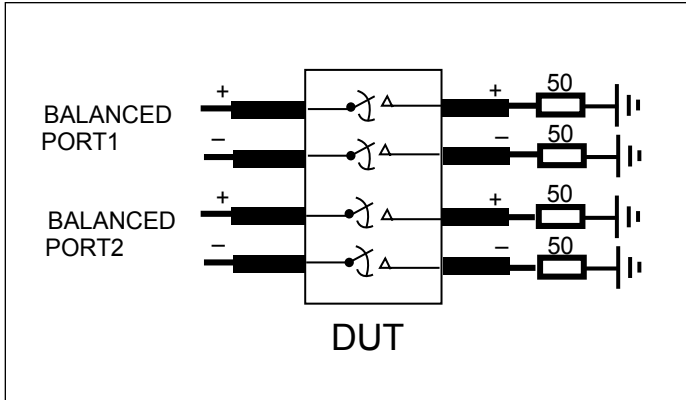

Fig 1. Crosstalk Setup

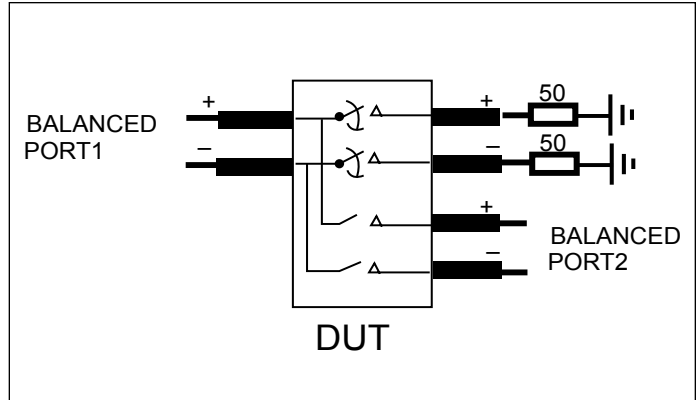

Fig 2. Off-Isolation Setup

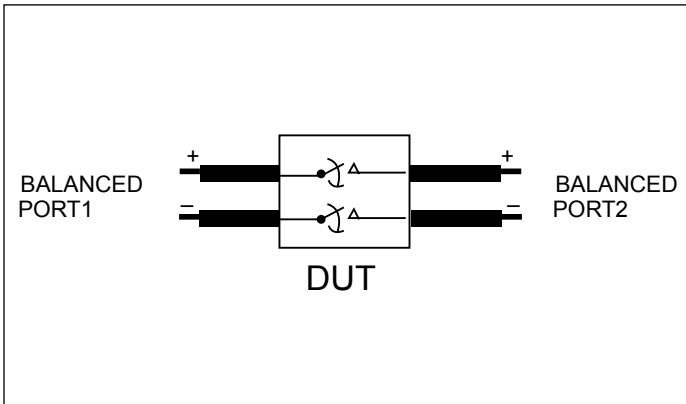
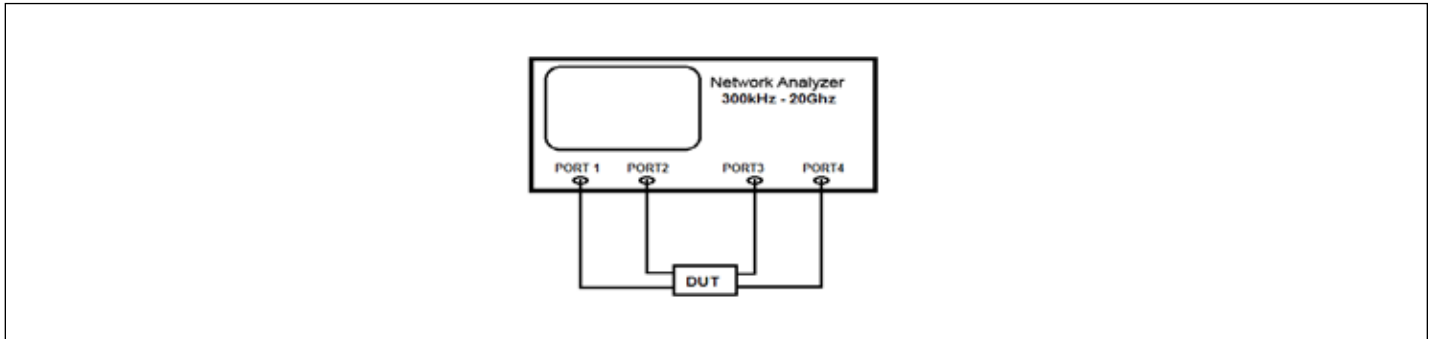
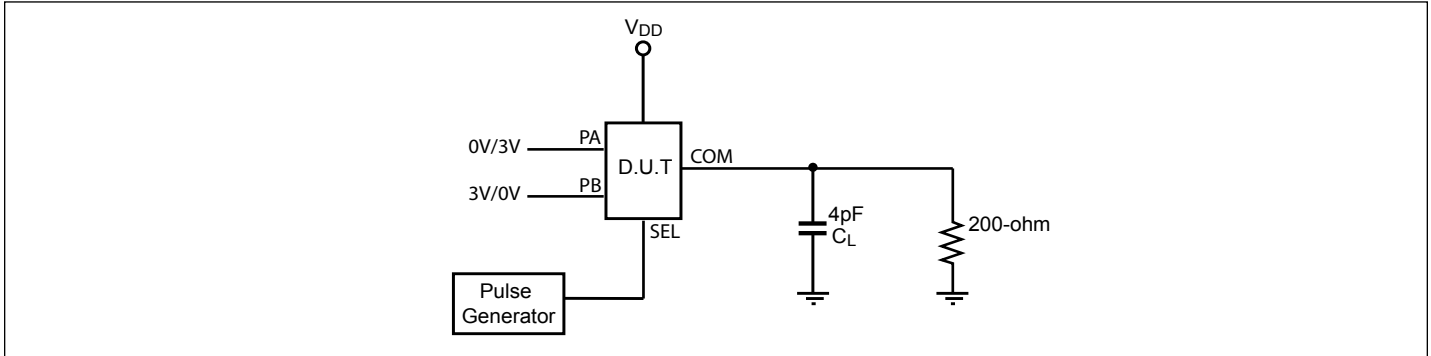

Fig 3. Differential Insertion Loss

Test Circuit for Dynamic Electrical Characteristics



Test Circuit for Electrical Characteristics⁽¹⁻⁴⁾



Notes:

1. C_L = Load capacitance: includes jig and probe capacitance.
2. R_T = Termination resistance: should be equal to Z_{OUT} of the Pulse Generator
3. All input impulses are supplied by generators having the following characteristics: $PRR \leq \text{MHz}$, $Z_O = 50\Omega$, $t_R \leq 2.5\text{ns}$, $t_F \leq 2.5\text{ns}$.
4. The outputs are measured one at a time with one transition per measurement.

Switching Waveforms

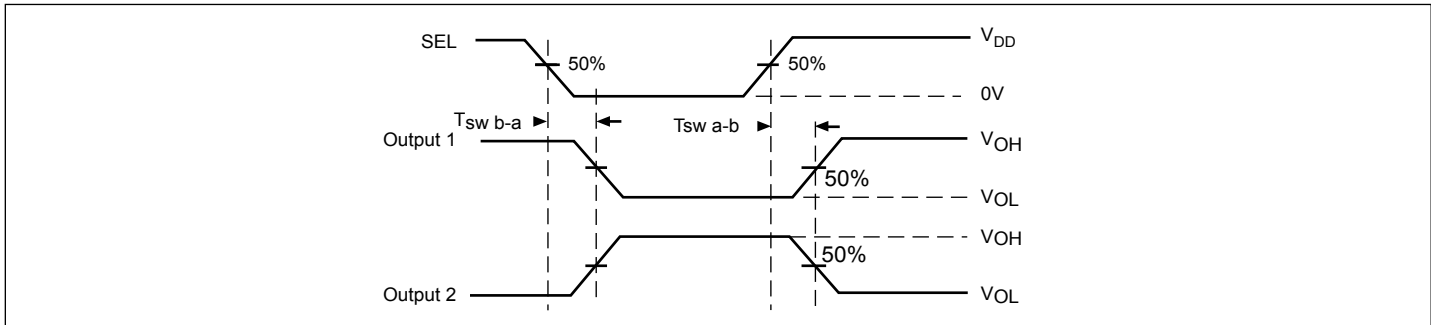

Voltage Waveforms for Select Timing

Test Condition

Output 1 Test Condition	Output 2 Test Condition
PA = Low	PA = High
PB = High	PB = Low

Part Marking

Top mark not available at this time. To obtain advance information regarding the top mark, please contact your local sales representative.

PI3WVR626

Packaging Mechanical:

24-X1QFN (XEB)

SYMBOLS	MIN.	NOM.	MAX.
A	0.40	0.45	0.50
A1	0.00	0.02	0.05
A3	0.127 REF.		
b	0.12	0.17	0.22
b1	0.07	0.12	0.17
D	2.50 BSC		
E	2.50 BSC		
e	0.35 BSC		
L	0.20	0.25	0.30
K	0.20	—	—
D2	1.35	1.40	1.45
E2	1.35	1.40	1.45

NOTE :

- ALL DIMENSIONS ARE IN mm. ANGLES IN DEGREES.
- COPLANARITY APPLIES TO THE EXPOSED THERMAL PAD AS WELL AS THE TERMINALS.
- REFER JEDEC MO-288
- RECOMMENDED LAND PATTERN IS FOR REFERENCE ONLY.
- THERMAL PAD SOLDERING AREA

DIODES PERICOM DATE: 06/26/19
INCORPORATED ENABLING SERIAL CONNECTIVITY
DESCRIPTION: 24-Contact, Extra Thin Fine Pitch QFN, X1QFN
PACKAGE CODE: XEB (XEB24)
DOCUMENT CONTROL #: PD-2243 REVISION: —

For latest package info.

please check: <http://www.diodes.com/design/support/packaging/pericom-packaging/packaging-mechanicals-and-thermal-characteristics/>

Ordering Information

Ordering Code	Package Code	Package Description
PI3WVR626XEBEX	XEB	24-Contact, Extra Thin Fine Pitch (X1QFN) QFN

Notes:

- No purposely added lead. Fully EU Directive 2002/95/EC (RoHS), 2011/65/EU (RoHS 2) & 2015/863/EU (RoHS 3) compliant.
- See <https://www.diodes.com/quality/lead-free/> for more information about Diodes Incorporated's definitions of Halogen- and Antimony-free, "Green" and Lead-free.
- Halogen- and Antimony-free "Green" products are defined as those which contain <900ppm bromine, <900ppm chlorine (<1500ppm total Br + Cl) and <1000ppm antimony compounds.
- E = Pb-free and Green
- X suffix = Tape/Reel

IMPORTANT NOTICE

DIODES INCORPORATED MAKES NO WARRANTY OF ANY KIND, EXPRESS OR IMPLIED, WITH REGARDS TO THIS DOCUMENT, INCLUDING, BUT NOT LIMITED TO, THE IMPLIED WARRANTIES OF MERCHANTABILITY AND FITNESS FOR A PARTICULAR PURPOSE (AND THEIR EQUIVALENTS UNDER THE LAWS OF ANY JURISDICTION).

Diodes Incorporated and its subsidiaries reserve the right to make modifications, enhancements, improvements, corrections or other changes without further notice to this document and any product described herein. Diodes Incorporated does not assume any liability arising out of the application or use of this document or any product described herein; neither does Diodes Incorporated convey any license under its patent or trademark rights, nor the rights of others. Any Customer or user of this document or products described herein in such applications shall assume all risks of such use and will agree to hold Diodes Incorporated and all the companies whose products are represented on Diodes Incorporated website, harmless against all damages.

Diodes Incorporated does not warrant or accept any liability whatsoever in respect of any products purchased through unauthorized sales channel.

Should Customers purchase or use Diodes Incorporated products for any unintended or unauthorized application, Customers shall indemnify and hold Diodes Incorporated and its representatives harmless against all claims, damages, expenses, and attorney fees arising out of, directly or indirectly, any claim of personal injury or death associated with such unintended or unauthorized application.

Products described herein may be covered by one or more United States, international or foreign patents pending. Product names and markings noted herein may also be covered by one or more United States, international or foreign trademarks.

This document is written in English but may be translated into multiple languages for reference. Only the English version of this document is the final and definitive format released by Diodes Incorporated.

LIFE SUPPORT

Diodes Incorporated products are specifically not authorized for use as critical components in life support devices or systems without the express written approval of the Chief Executive Officer of Diodes Incorporated. As used herein:

A. Life support devices or systems are devices or systems which:

1. are intended to implant into the body, or

2. support or sustain life and whose failure to perform when properly used in accordance with instructions for use provided in the labeling can be reasonably expected to result in significant injury to the user.

B. A critical component is any component in a life support device or system whose failure to perform can be reasonably expected to cause the failure of the life support device or to affect its safety or effectiveness.

Customers represent that they have all necessary expertise in the safety and regulatory ramifications of their life support devices or systems, and acknowledge and agree that they are solely responsible for all legal, regulatory and safety-related requirements concerning their products and any use of Diodes Incorporated products in such safety-critical, life support devices or systems, notwithstanding any devices- or systems-related information or support that may be provided by Diodes Incorporated. Further, Customers must fully indemnify Diodes Incorporated and its representatives against any damages arising out of the use of Diodes Incorporated products in such safety-critical, life support devices or systems.

Copyright © 2016, Diodes Incorporated

www.diodes.com

X-ON Electronics

Largest Supplier of Electrical and Electronic Components

Click to view similar products for [Multiplexer Switch ICs](#) category:

Click to view products by [Diodes Incorporated](#) manufacturer:

Other Similar products are found below :

[NLV74HC4066ADR2G](#) [HEF4051BP](#) [MC74HC4067ADTG](#) [DG508AAK/883B](#) [NLV14051BDG](#) [016400E](#) [PI3V512QE](#) [7705201EC](#)
[PI2SSD3212NCE](#) [PI3L100QE](#) [NLAS3257CMX2TCG](#) [PI5A3157BC6EX](#) [PI3V512QEX](#) [PI3DBS16213ZLEX](#) [PI3DBS16415ZHEX](#)
[PS509LEX](#) [MUX36S16IRSNR](#) [74LVC1G3157GM-Q10X](#) [TC7W53FK,LF](#) [CD4053BM96](#) [MC74HC4053ADWR2G](#) [MAX4051AEEE+](#)
[PI3L720ZHEX](#) [ADG1404YRUZ-REEL7](#) [ADG1208YRZ-REEL7](#) [CD4053BPWRG4](#) [ADG658TRUZ-EP](#) [FSA1256L8X_F113](#) [PI5V330QE](#)
[PI5V331QE](#) [5962-8771601EA](#) [ADG5249FBRUZ](#) [ADG1438BRUZ](#) [ADG5207BCPZ-RL7](#) [ADW54003-0](#) [AD7506JNZ](#) [AD7506KNZ](#)
[AD7506SQ](#) [AD8170AR](#) [AD8183ARUZ](#) [AD8184ANZ](#) [AD8185ARUZ](#) [AD8187ARUZ](#) [AD8188ARUZ](#) [AD8189ARUZ](#) [ADG1208YRUZ-](#)
[REEL7](#) [ADG1409YCPZ-REEL7](#) [ADG5209FBRUZ](#) [ADG1408YRUZ-REEL7](#) [ADG659YRUZ-REEL7](#)