

Features

- Low output skew: <270ps
- Switching frequency of 133 MHz
- Fast output rise/fall time <1.5ns
- Low propagation delay <3.0ns
- Low input capacitance <6.0pF
- Balanced CMOS outputs
- Industrial Temperature: -40°C to +85°C
- 3.3V ±10% operation
- Packaging: (Pb-free & Green Available)
 - 20-pin 300-mil wide QSOP (Q)
 - 20-pin 150-mil wide SSOP (H)

Description

Pericom Semiconductor's PI49FCT32805 is a fast speed, low skew, fast slew rate, and low propagation delay for most computing and communication applications.

The devices are non-inverting drivers. The outputs are configured into 2 groups of 1-in, 5-out with independent output enable. Group B has an extra MON output. Excellent output signals to power and ground ratio minimize power and ground noise, and also improves output performance.

PI49FCT32805 integrate series damping resistors on all outputs.

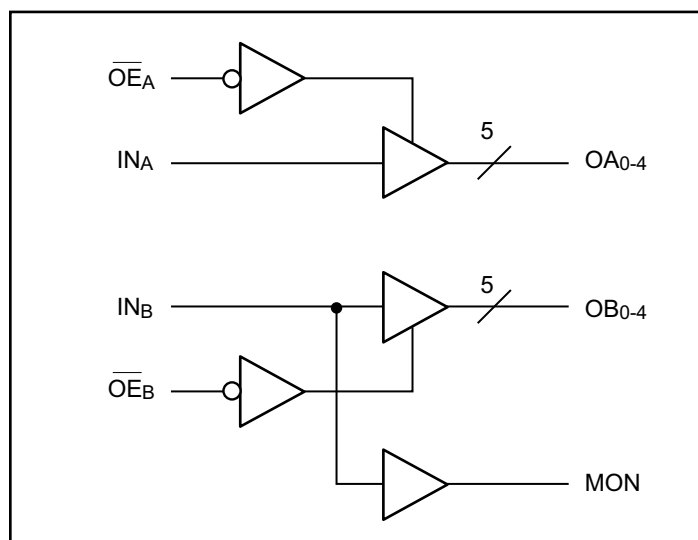
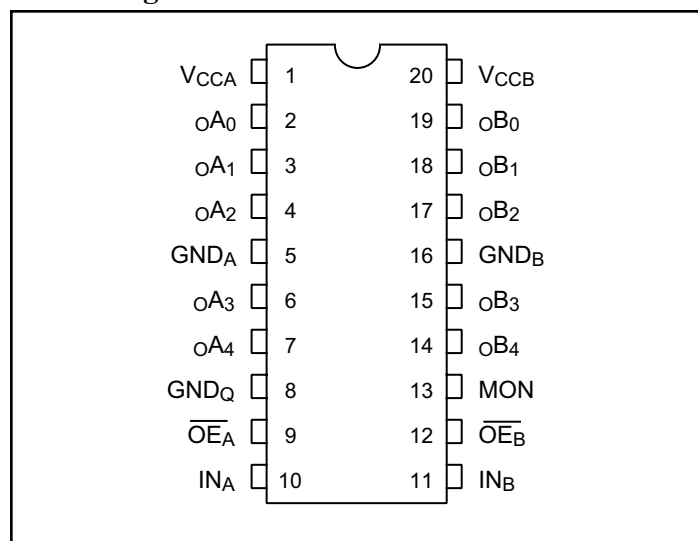
Block Diagram

Pin Configuration

Pin Description

Pin Name	Description
$\overline{OE}_A, \overline{OE}_B$	Hi-Z State Output Enable Inputs (Active LOW)
IN_A, IN_B	Clock Inputs
oA_N, oB_N	Clock Outputs
MON	Monitor Output
GND	Ground
V _{CC}	Power

Truth Table⁽¹⁾

Inputs		Outputs	
$\overline{OE}_A, \overline{OE}_B$	IN_A, IN_B	oA_N, oB_N	MON
L	L	L	L
L	H	H	H
H	L	Z	L
H	H	Z	H

Note:

1. H = High Voltage Level, L = Low Voltage Level
Z = High Impedance

Capacitance ($T_A = 25^\circ\text{C}$, $f = 1\text{ MHz}$)

Parameters ⁽¹⁾	Description	Test Conditions	Typ	Max.	Units
C_{IN}	Input Capacitance	$V_{IN} = 0\text{V}$		4	pF
C_{OUT}	Output Capacitance	$V_{OUT} = 0\text{V}$		6	

Note:

- This parameter is determined by device characterization.

Maximum Ratings

Storage Temperature	-65°C to $+150^\circ\text{C}$
Ambient Temperature with Power Applied	-40°C to $+85^\circ\text{C}$
Supply Voltage to Ground Potential (Inputs & V_{CC} Only)...	-0.5V to $+4.6\text{V}$
Supply Voltage to Ground Potential (Outputs & I/O Only)...	-0.5V to $+4.6\text{V}$
DC Input Voltage	-0.5V to $+4.6\text{V}$
DC Output Current.....	120 mA
Power Dissipation	0.5W

Note:

Stresses greater than those listed under MAXIMUM RATINGS may cause permanent damage to the device. This is a stress rating only and functional operation of the device at these or any other conditions above those indicated in the operational sections of this specification is not implied. Exposure to absolute maximum rating conditions for extended periods may affect reliability.

DC Electrical Characteristics ($T_A = -40^\circ\text{C}$ to $+85^\circ\text{C}$, $V_{CC} = 3.3\text{V} \pm 10\%$)

Symbol	Parameter	Test Condition ⁽¹⁾	Min.	Typ.	Max.	Units
V_{OH}	Output High Voltage $V_{CC} = 3.0\text{V}$, $V_{IN} = V_{IL}$ or V_{IH}	$I_{OH} = -8\text{mA}$	2.4 ⁽²⁾	3.0		V
V_{OL}	Output Low Voltage $V_{CC} = 3.0\text{V}$, $V_{IN} = V_{IL}$ or V_{IH}	$I_{OL} = +12\text{mA}$		0.4	0.5	
V_{IH}	Input High Voltage		2.0		$V_{CC}-0.2$	
V_{IL}	Input Low Voltage		-0.5		0.8	
I_{IH}	Input High Current	$V_{CC} = \text{Max.}$, $V_{IN} = V_{CC}$			1	μA
I_{IL}	Input Low Current	$V_{CC} = \text{Max.}$, $V_{IN} = \text{GND}$			-1	
I_{OZH}	High Impedance Output Current	$V_{CC} = \text{Max.}$, All outputs Disabled			$V_{OUT} = V_{CC}$ 1	
I_{OZL}	High Impedance Output Current	$V_{CC} = \text{Max.}$, All outputs Disabled			$V_{OUT} = \text{GND}$ -1	
V_{IK}	Clamp Diode Voltage	$V_{CC} = \text{Min.}$, $I_{IN} = -18\text{mA}$		-0.9	-1.2	V
I_{OH}	Output HIGH Current ⁽³⁾	$V_{OUT} = 1.5\text{V}$, $V_{IN} = V_{IL}$ or V_{IH} , $V_{CC} = 3.3\text{V}$	-25	-55	-80	mA
I_{OL}	Output LOW Current ⁽³⁾	$V_{OUT} = 1.5\text{V}$, $V_{IN} = V_{IL}$ or V_{IH} , $V_{CC} = 3.3\text{V}$	25	45	90	
I_{OS}	Short Circuit Current ⁽⁴⁾	$V_{CC} = \text{Max.}$, $V_{OUT} = \text{GND}$	-50	-100	-180	
R_S	Internal Series Resistor			20		Ω

Notes:

- For Max or Min conditions, use appropriate value specified under Electrical Characteristics for the applicable device type.
- $V_{OH} = V_{CC} - 0.6\text{V}$ at rated current.
- This parameter is guaranteed by device characterization.
- Not more than one output should be shorted at one time. Duration of the test should not exceed one second.

Power Supply Characteristics

Parameters	Description	Test Conditions ⁽¹⁾	Condition	Min.	Typ	Max.	Units
I_{CC}	Quiescent Power Supply Current	$V_{CC} = \text{Max}$	$V_{IN} = \text{GND}$ or V_{CC}		0.1	30	μA
ΔI_{CC}	Supply Current per Inputs @ TTL HIGH	$V_{CC} = \text{Max}$	$V_{IN} = V_{CC} - 0.6\text{V}$ ⁽²⁾		110	300	
I_{CCD}	Supply Current per Output per MHz ⁽³⁾	$V_{CC} = \text{Max}$, Outputs Open \overline{OE}_A or $\overline{OE}_B = \text{GND}$ 50% Duty Cycle	$V_{IN} = V_{CC}$ $V_{IN} = \text{GND}$		0.09 Per Output Toggling	0.16	mA/ MHz
I_C		$V_{CC} = \text{Max}$, Outputs Open $f_O = 10 \text{ MHz}$ 50% Duty Cycle \overline{OE}_A or $\overline{OE}_B = \text{GND}$ Mon. Outputs Toggling	$V_{IN} = V_{CC}$ $V_{IN} = \text{GND}$		1.3	9.0 ⁽⁴⁾	mA
			$V_{IN} = V_{CC} - 0.6\text{V}$ $V_{IN} = \text{GND}$		1.3	10.0 ⁽⁴⁾	
		$V_{CC} = \text{Max}$, Outputs Open $f_O = 2.5 \text{ MHz}$ 50% Duty Cycle \overline{OE}_A or $\overline{OE}_B = \text{GND}$ Eleven Outputs Toggling	$V_{IN} = V_{CC}$ $V_{IN} = \text{GND}$		4.4	6.0 ⁽⁴⁾	
			$V_{IN} = V_{CC} - 0.6\text{V}$ $V_{IN} = \text{GND}$		4.4	7.0 ⁽⁴⁾	

Notes:

1. For Max or Min conditions, use appropriate value specified under Electrical Characteristics for the applicable device.
2. Per TTL driven input ($V_{IN} = V_{CC} - 0.6\text{V}$); all other inputs at V_{CC} or GND.
3. This parameter is not directly testable, but is derived for use in Total Power Supply Calculations.
4. Values for these conditions are examples of the I_C formula. These limits are guaranteed but not tested.

Switching Characteristics

Symbol	Description	Condition	Max.	Units
t _{PLH} t _{PHL}	Propagation Delay A to B _N ⁽¹⁾	15pF	3.0	ns
t _R /t _F	Rise/Fall Time ⁽²⁾ 0.5V - 2.0V	15pF	1.5	
t _{SK(P)}	Pulse Skew ⁽²⁾	Same Output	0.35	
t _{SK(O)}	Output Skew ⁽²⁾	Same Package, Same Bank	0.27	
t _{SK(I)}	Package Skew ⁽²⁾	Same Package, Same Bank	0.55	
t _{ZL} , t _{ZH} t _{LZ} , t _{HZ}	Enable/Disable Time	15pF 500Ω	5.2	
F _{MAX}	Input Frequency	15pF	133	MHz

Notes:

1. Minimum propagation delay of 1.5ns is guaranteed but not tested.
2. These parameters are guaranteed by design

Switch Position

Test	Switch
Disable Low Enable Low	6V
Disable High Enable High	GND
All Other Inputs	Open

Tests Circuits for F_{IN} >100 MHz

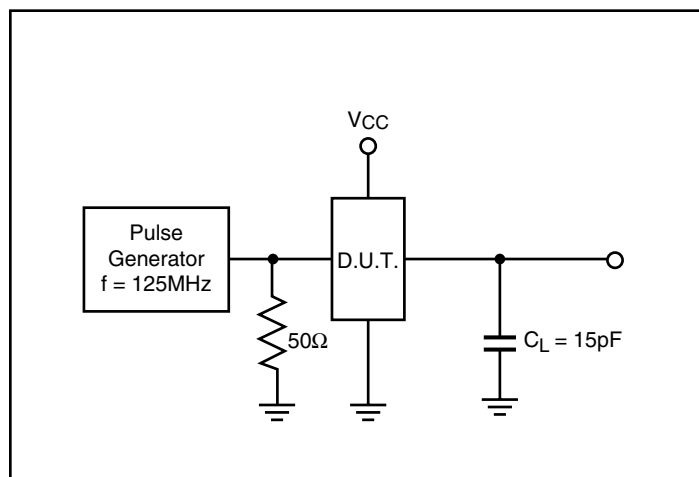

Enable/Disable Time Test Set-Up

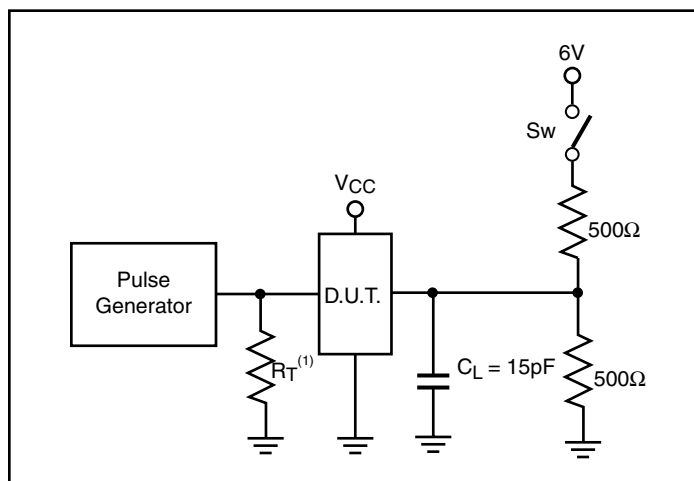

Note:

1. R_T = Termination resistance should be equal to Z_{OUT} of the Pulse Generator.

Switching Waveforms

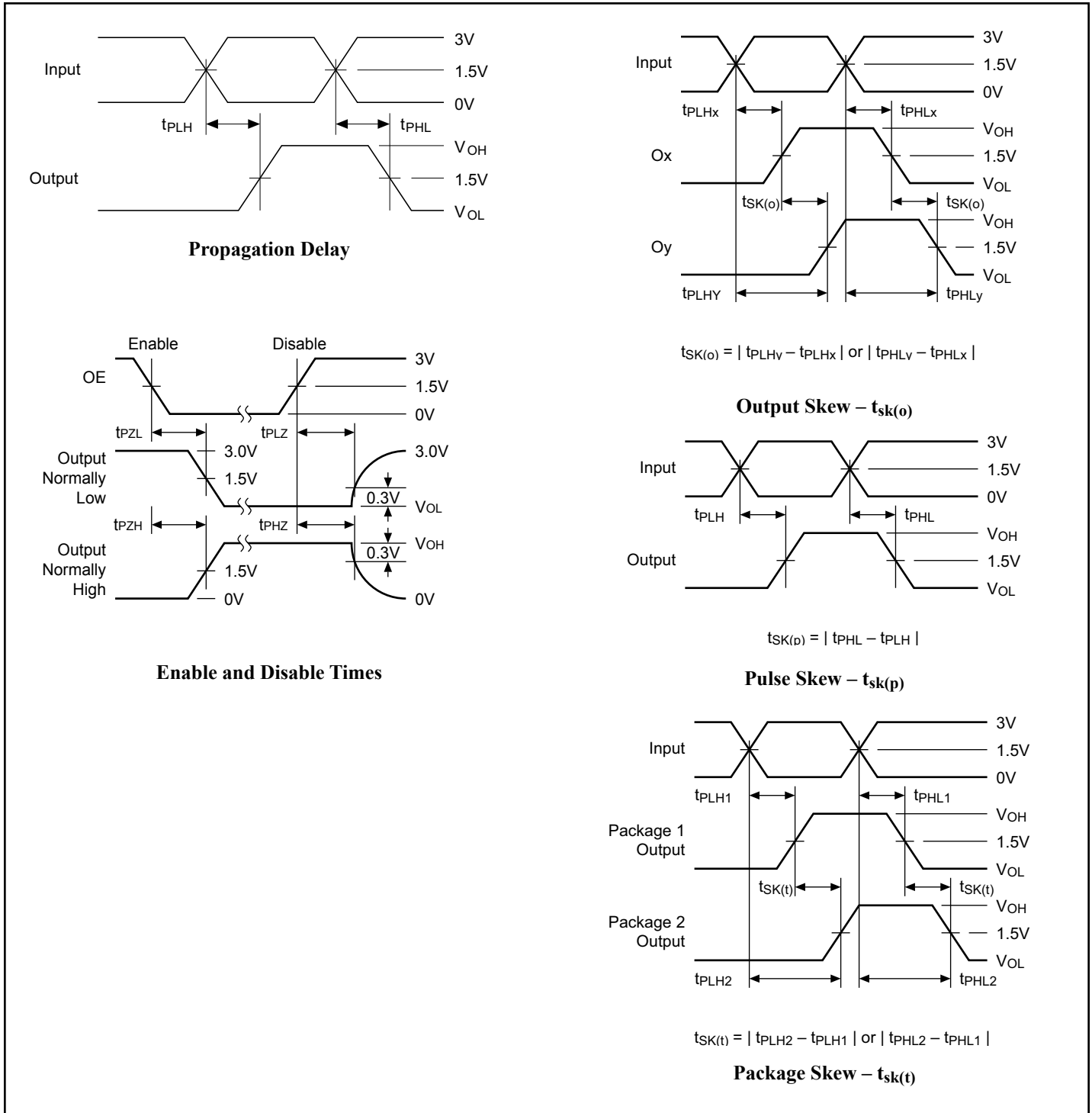

Packaging Mechanical: 20-Pin SOIC (H)

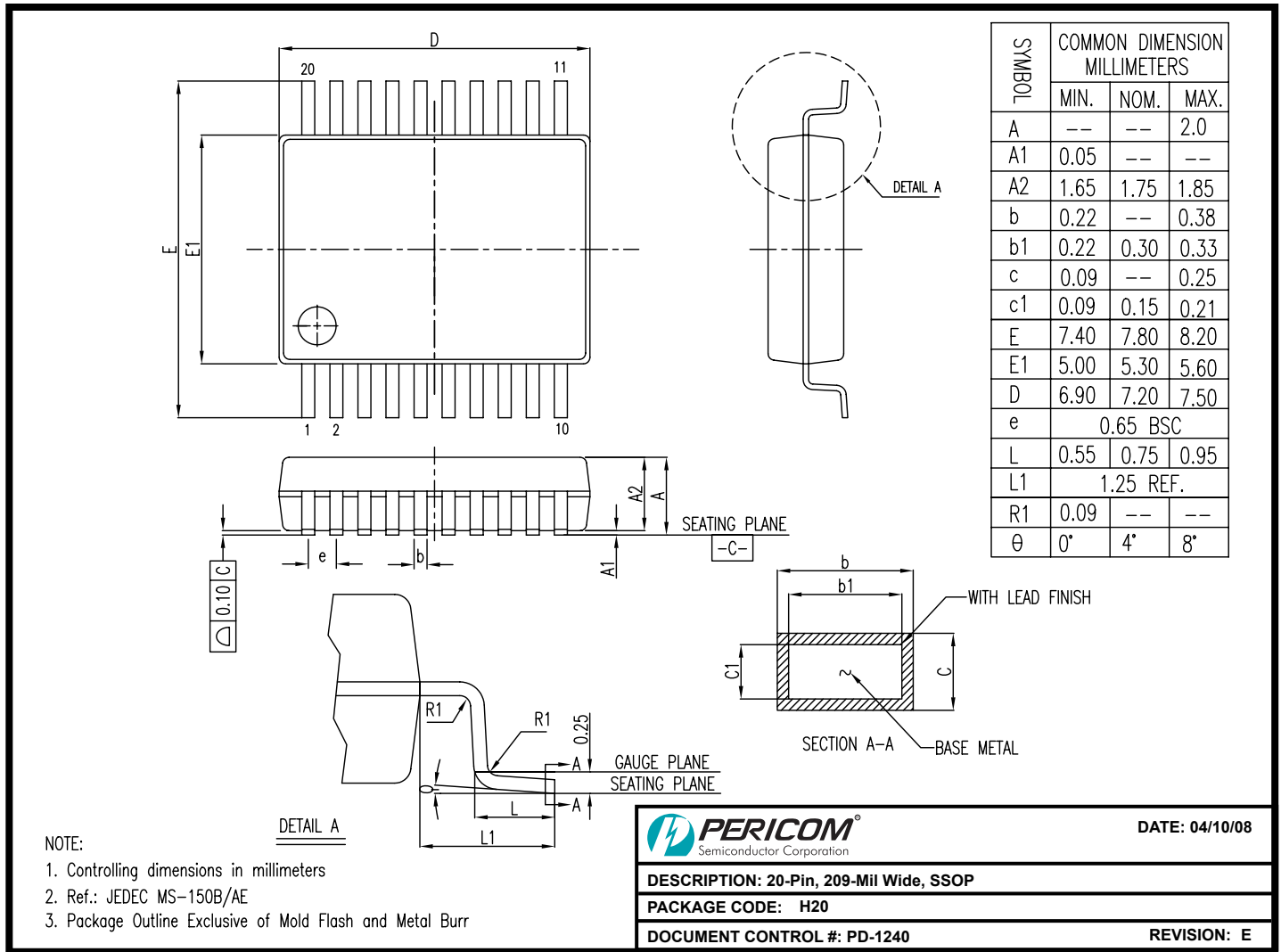

Packaging Mechanical: 20-Pin QSOP (Q)

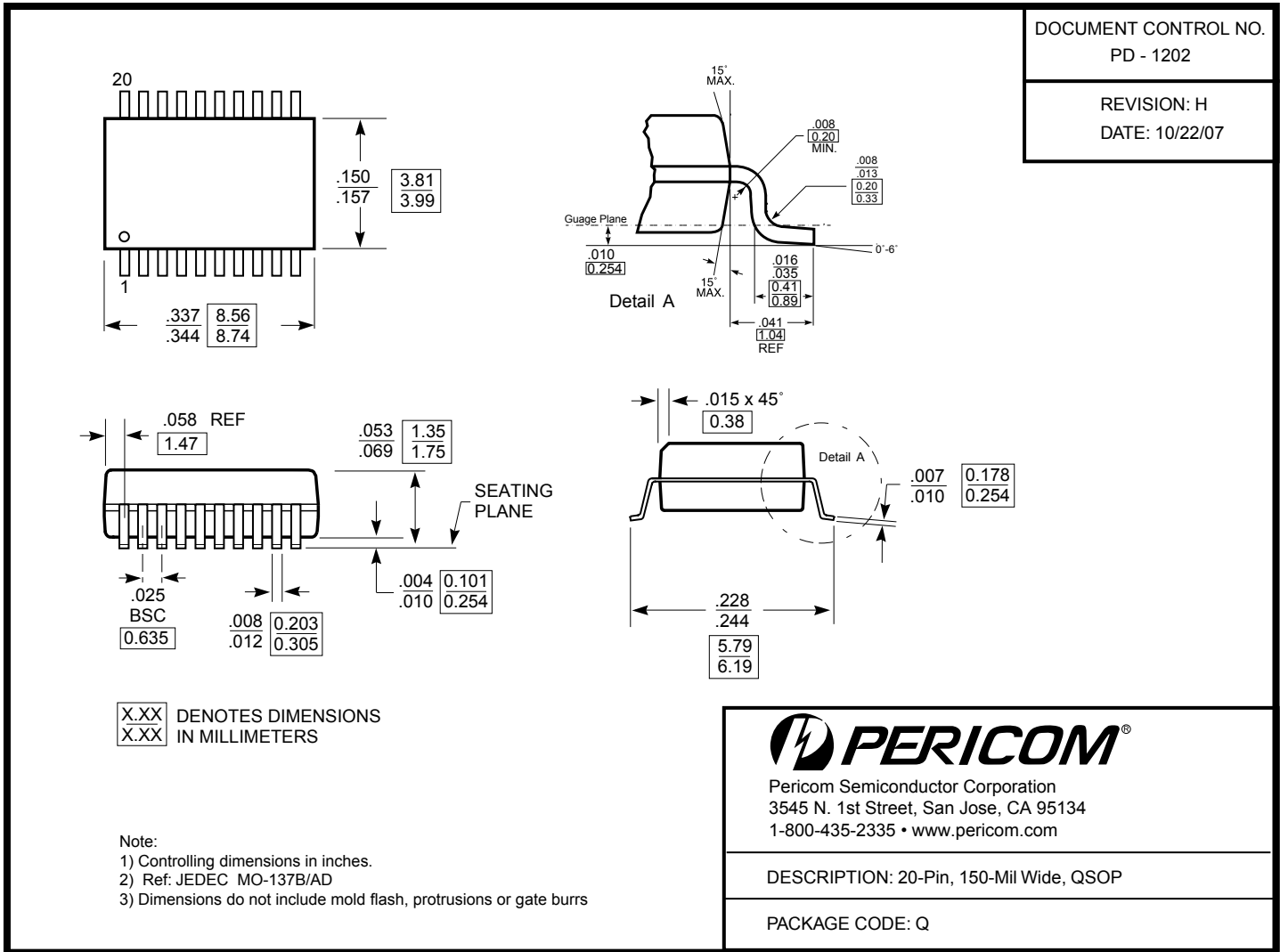

Ordering Information(1,2,3)

Ordering Code	Package Code	Package Description
PI49FCT32805HE	H	Pb-free & Green, 20-pin 150-mil QSOP
PI49FCT32805QE	Q	Pb-free & Green, 20-pin 300-mil SOIC

Notes:

1. Thermal characteristics can be found on the company web site at www.pericom.com/packaging/
2. E = Pb-free & Green
3. X suffix = Tape/Reel

X-ON Electronics

Largest Supplier of Electrical and Electronic Components

Click to view similar products for [Clock Buffer](#) category:

Click to view products by [Diodes Incorporated](#) manufacturer:

Other Similar products are found below :

[MPC962309EJ-1H](#) [NB4N121KMNG](#) [IDT49FCT805ASO](#) [MK2308S-1HILF](#) [PL133-27GI-R](#) [NB3L02FCT2G](#) [NB3L03FCT2G](#)
[ZL40200LDG1](#) [ZL40205LDG1](#) [9FG1200DF-1LF](#) [9FG1001BGLF](#) [PI49FCT20802QE](#) [NB7L1008MNG](#) [NB7L14MN1G](#) [PI49FCT20807QE](#)
[PI6C4931502-04LIEX](#) [ZL80002QAB1](#) [PI6C4931504-04LIEX](#) [PI6C10806BLEX](#) [ZL40226LDG1](#) [8T73S208B-01NLGI](#) [SY75578LMG](#)
[PI49FCT32805QEX](#) [PL133-27GC-R](#) [CDCV304PWG4](#) [MC10LVEP11DG](#) [MC10EP11DTG](#) [MC100LVEP11DG](#) [MC100E111FNG](#)
[MC100EP11DTG](#) [NB7L14MMNG](#) [NB6L14MMNR2G](#) [NB6L611MNG](#) [NB7V58MMNHTBG](#) [NB3N111KMNR4G](#) [ADCLK944BCPZ-R7](#)
[ZL40217LDG1](#) [NB7LQ572MNG](#) [HMC940LC4BTR](#) [9DB801BGLF](#) [ADCLK946BCPZ-REEL7](#) [ADCLK946BCPZ](#) [ADCLK905BCPZ-R2](#)
[ADCLK905BCPZ-R7](#) [ADCLK907BCPZ-R2](#) [ADCLK907BCPZ-WP](#) [ADCLK914BCPZ-R2](#) [ADCLK914BCPZ-R7](#) [ADCLK925BCPZ-R2](#)
[ADCLK925BCPZ-R7](#)