

1:5/1:7 Clock Buffer for Networking Applications

Features

- High Frequency >156 MHz
- High-speed, low-noise, non-inverting buffer
 - PI49FCT3802 is 1:5 buffer
 - PI49FCT3803 is 1:7 buffer
- Low-skew (<250ps) between any two output clocks
- Low duty cycle distortion <250ps
- Low propagation delay <2.5ns
- 5V Tolerant input
- Multiple V_{DD}, GND pins for noise reduction
- 3.3V supply voltage
- Packaging (Pb-free & Green available):
 - 16-pin TSSOP (L)
 - 16-pin QSOP (Q)

Description

The PI49FCT380x is a 3.3V compatible, high-speed, low-noise non-inverting clock buffer. The key goal in designing the PI49FCT380x is to target networking applications that require low-skew, low-jitter, and high-frequency clock distribution. Providing output-to-output skew as low as 250ps, the PI49FCT380x is an ideal clock distribution device for synchronous systems. Designing synchronous networking systems requires a tight level of skew from a large number of outputs.

Pin Description

Pin Name		Description
3802	3803	
BUF_IN	BUF_IN	Input
CLK[0:4]	CLK[0:4]	Outputs
GND	GND	GND
V _{DD}	V _{DD}	Power

Block Diagram (PI49FCT3802)

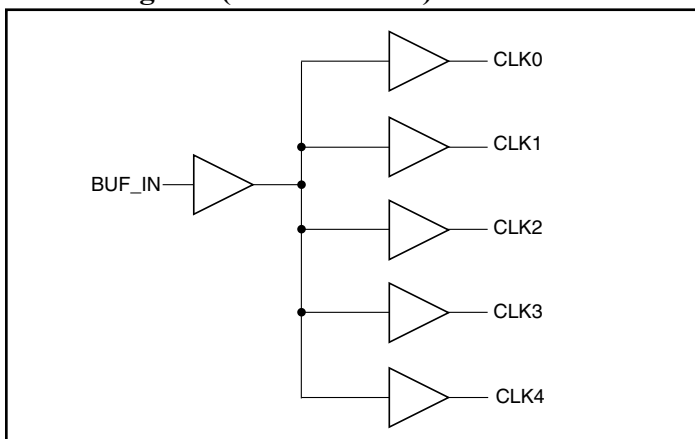

Pin Configuration (PI49FCT3802)

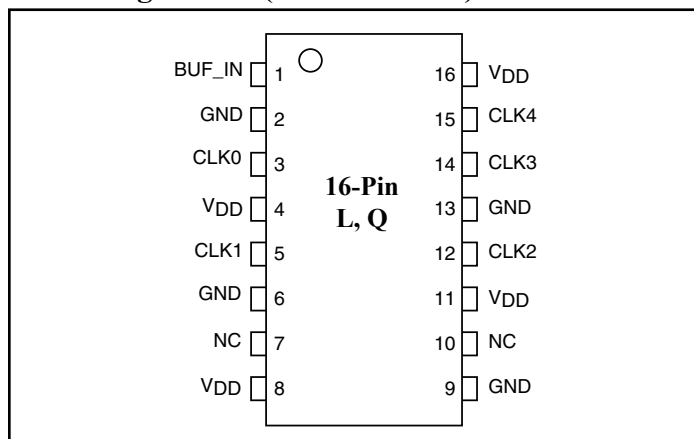

Block Diagram (PI49FCT3803)

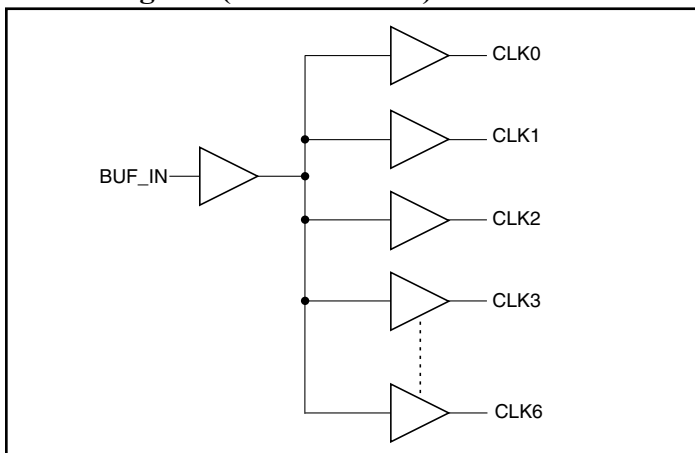

Pin Configuration (PI49FCT3803)

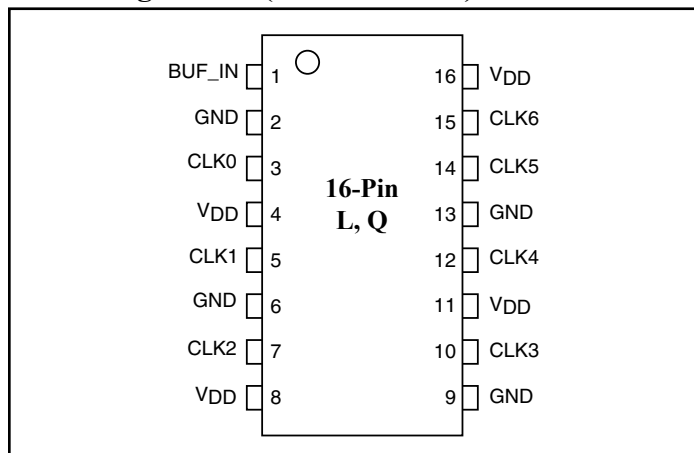

Maximum Ratings

(Above which the useful life may be impaired. For user guidelines, not tested.)

Storage Temperature.....	-65°C to +150°C
V _{DD} Voltage	-0.5V to 5.5V
Output Voltage.....	-0.5V to 5.5V
Input Voltage	-0.5V to 5.5V
DC Output Current.....	-60mA to +60mA
Power Dissipation	500mW

Note:

Stresses greater than those listed under MAXIMUM RATINGS may cause permanent damage to the device. This is a stress rating only and functional operation of the device at these or any other conditions above those indicated in the operational sections of this specification is not implied. Exposure to absolute maximum rating conditions for extended periods may affect reliability.

Operating Range

V _{DD} Voltage	3.3V ± 0.3V
Commercial Temperature.....	0°C to +70°C
Industrial Temperature	-40°C to +85°C
Input Frequency	DC to 156 MHz
Capacitive Loading	10pF to 50pF

DC Electrical Characteristics (Over the Operating Range)

Parameters	Description	Test Conditions ⁽¹⁾	Min.	Typ. ⁽²⁾	Max.	Units
V _{IH}	Input HIGH Voltage	Guaranteed Logic HIGH Level (Input Pins)	2.0		5.5	V
V _{IL}	Input LOW Voltage	Guaranteed Logic LOW Level (Input Pins)	-0.5		0.8	
I _{IH}	Input HIGH Current	V _{DD} = Max. V _{IN} = V _{DD}			1	µA
I _{IL}	Input LOW Current	V _{DD} = Max. V _{IN} = GND			-1	
V _{IK}	Clamp Diode Voltage	V _{DD} = Min., I _{IN} = -18mA		-0.7	-1.2	V
V _{OH}	Output HIGH Voltage	V _{CC} = Min., V _{IN} = V _{IH} or V _{IL}	I _{OH} = -0.1mA	V _{DD} -0.2		
			I _{OH} = -12mA	2.4 ⁽³⁾	3.0	
V _{OL}	Output LOW Voltage	V _{CC} = Min., V _{IN} = V _{IH} or V _{IL}	I _{OH} = 0.1mA		0.2	
			I _{OH} = 12mA		0.3	0.5
I _{OH}	Output HIGH Current	V _{DD} = 3.0V, V _{IN} = V _{IH} OR V _{IL} , V _{OUT} = 1.5V ⁽⁴⁾	-45	-75	-180	mA
I _{OL}	Output LOW Current	V _{DD} = 3.0V, V _{IN} = V _{IH} OR V _{IL} , V _{OUT} = 1.5V ⁽⁴⁾	50	92	200	

Notes:

- For Max. or Min. conditions, use appropriate value specified under Electrical Characteristics for the applicable device type.
- Typical values are at V_{DD} = 3.3V, +25°C ambient and maximum loading.
- V_{OH} = V_{DD} - 0.6V at rated current.
- This parameter is determined by device characterization but is not production tested.
- Not more than one output should be shorted at one time. Duration of the test should not exceed one second.

Power Supply Characteristics

Parameters	Description	Test Conditions		Min.	Typ. ⁽²⁾	Max.	Units
I _{DDQ}	Quiescent Power Supply Current	V _{DD} = Max.	V _{IN} = GND or V _{DD}		0.1	30	μA
ΔI _{DD}	Supply Current per Inputs @ TTL High	V _{DD} = Max.	V _{IN} = V _{DD} - 0.6V(3)		47	300	
I _{DD}	Dynamic Supply Current	V _{DD} = 3.6V, No load	50 MHz		43		mA
			67 MHz		56		
			80 MHz		66		
			100 MHz		81		
			125 MHz		97		
			156 Mhz		121		

Notes:

- For Max. or Min. conditions, use appropriate value specified under Electrical Characteristics for the applicable device.
- Typical values are at V_{DD} = 3.3V, +25°C ambient.
- Per TTL driven input (V_{IN} = V_{DD} - 0.6V); all other inputs at V_{DD} or GND.

Capacitance (T_A = 25°C, f = 1 MHz)

Parameters ⁽¹⁾	Description	Test Conditions	Typ	Max.	Units
C _{IN}	Input Capacitance	V _{IN} = 0V	3.0	4	pF
C _{OUT}	Output Capacitance	V _{OUT} = 0V	—	6	

Note:

- This parameter is determined by device characterization but is not production tested.

Switching Characteristics (V_{DD} = 3.3V ± 0.3V, T_A = 85°C)

Parameters	Description	Test Conditions	Min.	Typ.	Max.	Units
t _R /t _F	CLK _n Rise/Fall Time 0.8V ~ 2.0V	C _L = 15pF, 125 Mhz		0.7	1.0	ns
t _{PLH} t _{PHL}	Propagation Delay BUF_IN to CLK _n		1.0	2.2	2.5	
t _{sk(o)} ⁽³⁾	Skew between two outputs of the same package (same transition)			110	250	ps
t _{sk(p)} ⁽³⁾	Skew between opposite transitions (t _{PHL} - t _{PLH}) of the same output			200	250	
t _{sk(t)} ⁽³⁾	Skew between two outputs of different packages ⁽⁴⁾				0.55	ns

Notes:

- See test circuit and waveforms.
- Minimum limits are guaranteed but not tested on Propagation Delays.
- Skew measured at worse cast temperature (max. temp).
- Identical conditions: loading, transitions, supply voltage, temperature, package type and speed grade.

Switching Waveforms

Propagation Delay

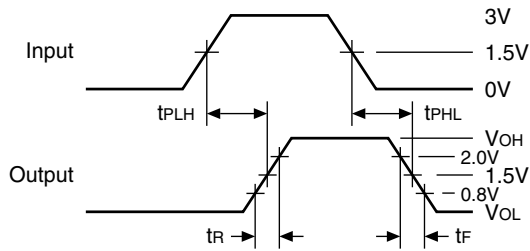

Pulse Skew – $t_{SK(P)}$

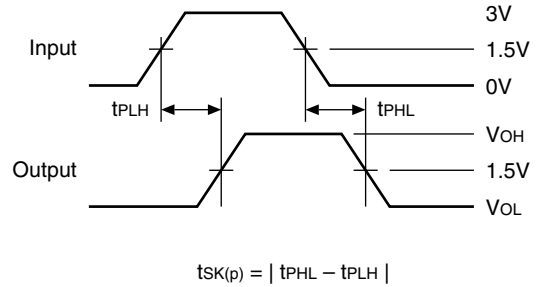

Output Skew – $t_{SK(O)}$

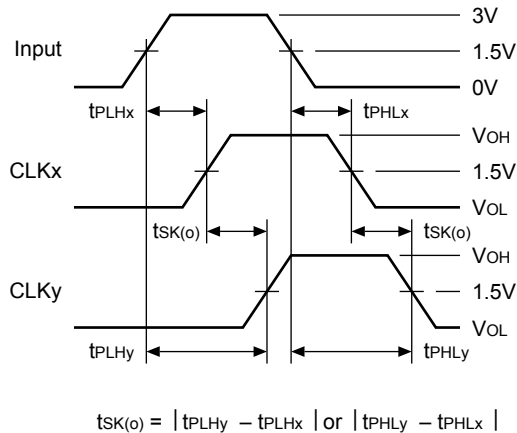

Package Skew – $t_{SK(T)}$

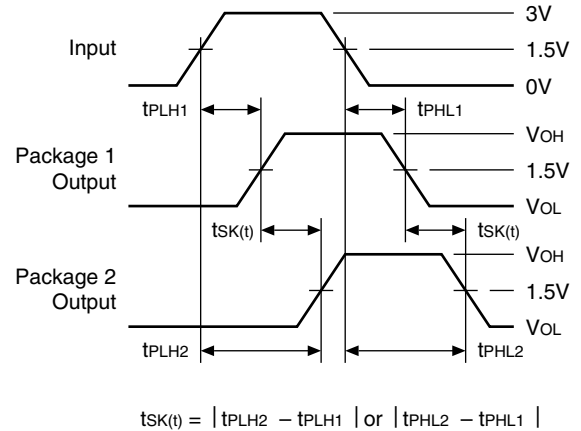

Test Circuits for All Outputs

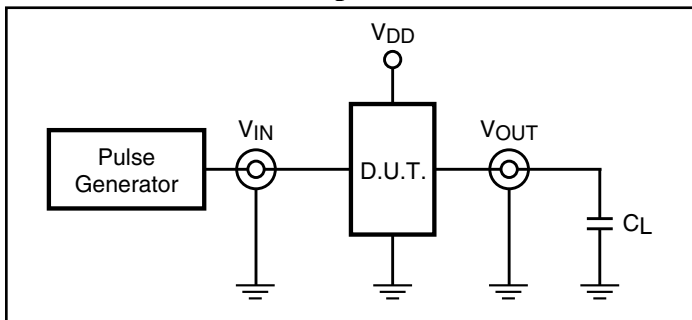

Definitions:

C_L = Load capacitance: includes jig and probe capacitance.

R_T = Termination resistance, should be equal to Z_{out} of the Pulse Generator.

Ordering Information

Ordering Code	Package Code	Package Description
PI49FCT3802L	L	16-pin TSSOP
PI49FCT3802LE	L	Pb-free & Green, 16-pin TSSOP
PI49FCT3802Q	Q	16-pin QSOP
PI49FCT3802QE	Q	Pb-free & Green, 16-pin QSOP
PI49FCT3803L	L	16-pin TSSOP
PI49FCT3803LE	L	Pb-free & Green, 16-pin TSSOP
PI49FCT3803Q	Q	16-pin QSOP
PI49FCT3803QE	Q	Pb-free & Green, 16-pin QSOP

Notes:

1. Thermal characteristics can be found on the web at www.pericom.com/packaging/

X-ON Electronics

Largest Supplier of Electrical and Electronic Components

Click to view similar products for [Clock Buffer](#) category:

Click to view products by [Diodes Incorporated](#) manufacturer:

Other Similar products are found below :

[9DBV0941AKLF](#) [MPC962309EJ-1H](#) [NB4N121KMNG](#) [NB7VQ58MMNG](#) [IDT49FCT805ASO](#) [MC10E111FNG](#) [MK2308S-1HILF](#)
[6V31024NLG](#) [PL133-27GI-R](#) [NB3L02FCT2G](#) [NB3L03FCT2G](#) [NB7VQ58MMNHTBG](#) [ZL40203LDG1](#) [ZL40200LDG1](#) [ZL40205LDG1](#)
[PI49FCT32807QE](#) [9FG1200DF-1LF](#) [9FG1001BGLF](#) [ZL40202LDG1](#) [PI49FCT20802QE](#) [SL2305SC-1T](#) [PI6C4931502-04LIE](#)
[5P1103A517NLGI](#) [NB7L1008MNG](#) [NB7L14MN1G](#) [PI49FCT20807QE](#) [PI6C4931502-04LIEEX](#) [ZL80002QAB1](#) [8T73S1802NLGI/W](#)
[PI6C4931504-04LIEEX](#) [5P1103A515NLGI](#) [PI6C10806BLEX](#) [5P1105A504NLGI](#) [ZL40226LDG1](#) [ZL40206LDG1](#) [ZL40219LDG1](#)
[8T73S208B-01NLGI](#) [8T39S11ANLGI8](#) [MC100EP11DR2G](#) [W256H](#) [Si53301-B-GMR](#) [SI5330C-B00209-GM](#) [NB3RL02FCT2G](#)
[SY75578LMG](#) [PI49FCT32803QE](#) [PI49FCT32805QEX](#) [PI49FCT3807CQE](#) [PL133-27GC-R](#) [PI49FCT32805QE](#) [LMK00804BPWR](#)