

1.2V to 3.6V Universal Bidirectional Level Shifter with Automatic Direction Control

Features

- PI4ULS3V08M is designed for low voltage operation: 1.2V to 3.6V
- Universal bidirectional level shifting with automatic direction control
- Fast bus speeds up to 90 Mbps for push-pull application
- Drive Capability 12mA
- Independent translation of each bit
- Each supply rail is configurable over supply range
- ESD Protection exceeds JESD22
 - 2000V Human Body Model (A114-B)
 - 200V Machine Model (A115-A)
- Latch-up performance exceeds 100mA per JESD 78
- Industrial operation at -40 °C to +85 °C
- Package: 32-contact TQFN 3x6

Pin Configuration

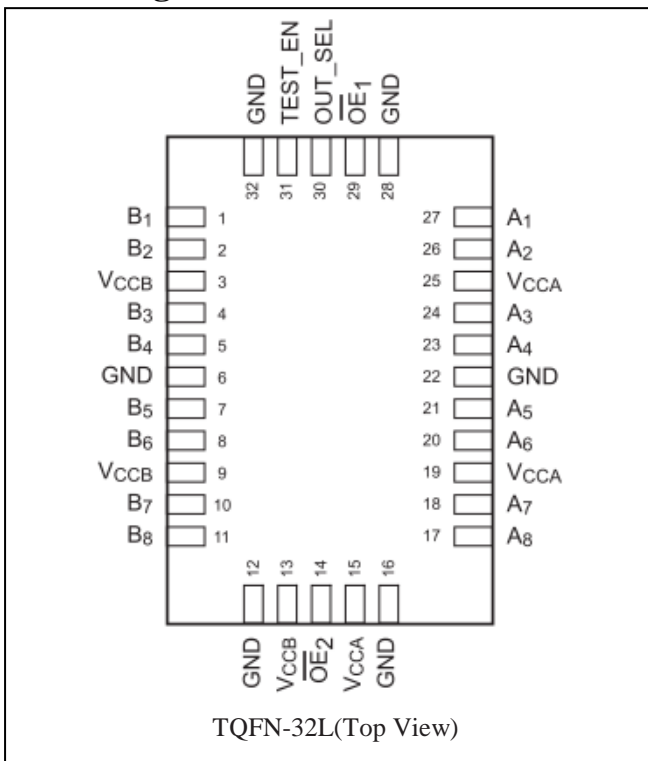

Description

PI4ULS3V08M, is a 8-bit (octal) non-inverting bus transceiver with two separate supply rails: A port (VCCA) and B port (VCCB) are set to operate at 1.2V to 3.6V. This arrangement permits universal bidirectional translation of differential signal levels over the voltage ranges.

The PI4ULS3V08M is designed for asynchronous communication between data buses. Data is transmitted from the A bus to the B bus, or vice versa, without direction control. All AX, and BX are tri-stated when data is coming from both directions at the same time. The output-enable (\overline{OE}) input is used to disable outputs so buses are isolated.

The control pins \overline{OE}_x , TEST_EN and OUT_SEL are supplied by VCCB.

To ensure the high impedance state during power-up or power-down, the output-enable (\overline{OE}_x) input should be tied to VCC through a pull-up resistor: the minimum value of the resistor is determined by the current-sinking capability of the driver.

Applications

- Voltage Translation
- Bus Relay
- Mobile Devices

Pin Description

Pin Name	Description
\overline{OE}_x	3-State Output Enable Inputs (Active Low)
Ax	Side A Inputs/Outputs
Bx	Side B Inputs/Outputs
TEST_EN	Enable Test Mode
OUT_SEL	Output impedance select
GND	Ground
VCCA, VCCB	Power

Block Diagram

Figure 1: Block Diagram

Truth Table

Input OEx	Outputs Loading	Operation
L	$C_L \leq 50\text{pF}$	Bus B data to Bus A, or Bus A data to Bus B
H		Z (Isolation)

Note:

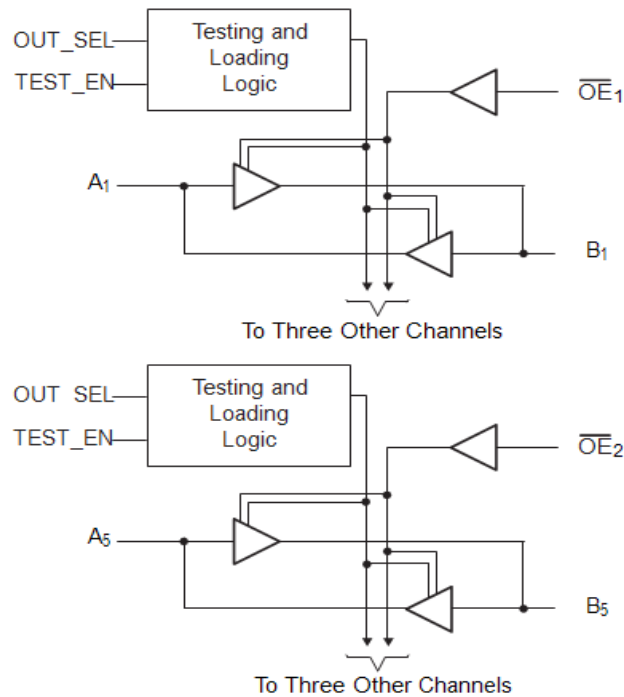
- H = HIGH Signal Level, L = LOW Signal Level
Z = High Impedance

Test Mode / Output Impedance Select

TEST_EN	Out_SEL	Conditions
L	L	Normal Operation Low output impedance 300Ω
L	H	Normal Operation High output impedance 2.2KΩ
H	L	Test_MODE A → B
H	H	Test_MODE B → A

Maximum Ratings

Storage Temperature	-65°C to +150°C
DC Supply Voltage VCCA	-0.5V to +4.6V
DC Supply Voltage VCCB	-0.5V to +4.6V
Enable Control Pin DC Input Voltage	-0.5V to +4.6V
Voltage Range applied to any I/O pins in the high-impedance or Power-Off state VIOZ(A)	-0.5V to +4.6V
Voltage Range applied to any I/O pins in the high-impedance or Power-Off state VIOZ(B)	-0.5V to +4.6V
Voltage Range applied to any I/O pins in the high or Low state VIO(A)	-0.5V to V _{CCA} +0.5V
Voltage Range applied to any I/O pins in the high or Low state VIO(B)	-0.5V to V _{CCB} +0.5V
Input clamp Current (VI < 0)	-50mA
Output clamp current (VO < 0)	-50mA
Continuous output current	±20mA
Continuous current through VCCA, VCCB or GND Pin	±100mA

Note:

- The input negative voltage and output voltage ratings may be exceeded if the input and output current ratings are observed.
- This value is limited to 3.6V maximum.
- Stresses greater than those listed under MAXIMUM RATINGS may cause permanent damage to the device. This is a stress rating only and functional operation of the device at these or any other conditions above those indicated in the operational sections of this specification is not implied. Exposure to absolute maximum rating conditions for extended periods may affect reliability.

Recommended Operating Conditions

Parameter	Description		V _{CCI}	Min	Max	Units
V _{CCA} , V _{CCB}	Supply Voltage		-	1.2	3.6	V
V _{IH}	High-Level Input	I/O pins	1.2V to 1.95V	0.65 x V _{CCI}	-	
			2.3V to 2.7V	1.7	-	
			2.7V to 3.6V	2	-	
V _{IL}	Low-Level Input	I/O pins	1.2V to 1.95V	-	0.35 x V _{CCI}	
			2.3V to 2.7V	-	0.7	
			2.7V to 3.6V	-	0.8	
V _{IHB}	High-Level Input Voltage	Control Inputs (OE)	1.2V to 1.95V	0.65 x V _{CCB}	-	
			2.3V to 2.7V	1.7	-	
			2.7V to 3.6V	2	-	
V _{ILB}	Low-Level Input Voltage	Control Inputs (OE)	1.2V to 1.95V	-	0.35 x V _{CCB}	
			2.3V to 2.7V	-	0.7	
			2.7V to 3.6V	-	0.8	
V _I	Input Voltage	I/O pins and Control	-	0	3.6	
V _O	Output Voltage	I/O pins and Control	-	0	3.6	
I _{OH}	High-Level Output	I/O pins	V _{CCO} = 1.2V	-	-3	
			V _{CCO} = 1.4V	-	-5	
			V _{CCO} = 1.65V	-	-8	
			V _{CCO} = 2.3V	-	-9	
			V _{CCO} = 3.0V	-	-12	
I _{OL}	Low-Level Output	I/O pins	V _{CCO} = 1.2V	-	3	
			V _{CCO} = 1.4V	-	5	
			V _{CCO} = 1.65V	-	8	
			V _{CCO} = 2.3V	-	9	
			V _{CCO} = 3.0V	-	12	
ΔV/Δt	Input Transition rise or fall rate		-	-	10	V/ns
T _A	Operating Free-Air Temperature		-	-40	85	°C

Notes:

1. V_{CCI} is the V_{CC} associated with the data input port.
2. V_{CCO} is the V_{CC} associated with the data output port.
3. To ensure proper device operation, all unused device inputs must be held at V_{CCI} or GND.

Electrical Characteristics

(Over recommended free-air temperature range, unless otherwise noted.)

Parameter	Description	Test Conditions	V _{CCA} /V _{CCB}	Min	Typ ⁽¹⁾	Max	Units
V _{OH}	High-Level Output Voltage	I _{OH} = -100μA	1.2V to 3.6V	V _{CCO} - 0.1V	-	-	V
		I _{OH} = -2mA	1.2V	-	0.8	-	
		I _{OH} = -4mA	1.4V	1	-	-	
		I _{OH} = -7mA	1.65V	1.2	-	-	
		I _{OH} = -9mA	2.3V	1.8	-	-	
		I _{OH} = -12mA	3.0V	2.4	-	-	
V _{OL}	Low-Level Output Voltage	I _{OL} = 100μA	1.2V to 3.6V	-	-	0.2	V
		I _{OL} = 2mA	1.2V	-	0.1	-	
		I _{OL} = 4mA	1.4V	-	-	0.4	
		I _{OL} = 7mA	1.65V	-	-	0.4	
		I _{OL} = 9mA	2.3V	-	-	0.4	
		I _{OL} = 12mA	3.0V	-	-	0.4	
I _{CC}	Quiescent Supply Current	V _I = V _{CCI} or GND, I _O = 0	1.2V to 3.6V	-	-	10	μA
I _I	Control Inputs (OE and SEL)	V _I = V _{CCB} or GND	1.2V to 3.6V	-	-	±5	
I _{OZ} ⁽²⁾	3-State Output Current	V _O = V _{CCO} or GND	1.2V to 3.6V	-	-	±10	
C _{IN}	Control Input Capacitance	V _I = V _{CCB} or GND	-	-	3	-	pF
C _{IO}	I/O Capacitance	V _I = V _{CCA/B} or GND	-	-	5	-	

Notes:

- All typical values are at T_A = 25 °C.
- For I/O ports, the parameter I_{OZ} includes the input leakage current.
- Parameters are specified under test mode conditions.

Timing Characteristics

(V_{CCA} = 1.5V ±0.1V, Over recommended free-air temperature range, unless otherwise noted.)

Parameter	From (Input)	To (Output)	V _{CCB} = 1.2V		V _{CCB} = 1.5V ±0.1V		V _{CCB} = 1.8V ±0.15V		V _{CCB} = 2.5V ±0.2V		V _{CCB} = 3.3V ±0.3V		Units
			Typ	Min	Max	Min	Max	Min	Max	Min	Max		
t _{PD}	A	B	8	1.0	7.0	1.0	6.5	1.0	6.0	1.0	5.0	ns	
	B	A	6	1.0	7.0	1.0	6.5	1.0	6.0	1.0	5.5		
tsk(a) ⁽¹⁾	-	-	-	-	0.3	-	0.3	-	0.3	-	0.3		
tsk(b) ⁽¹⁾	-	-	-	-	0.25	-	0.25	-	0.25	-	0.25		
f _{max} 10pF load	B	A	12	15	-	20	-	22	-	25	-	MHz	
	A	B	15	15	-	15	-	16	-	17	-		

($V_{CCA} = 1.8V \pm 0.15V$, Over recommended free-air temperature range, unless otherwise noted.)

Parameter	From (Input)	To (Output)	$V_{CCB} = 1.2V$	$V_{CCB} = 1.5V \pm 0.1V$		$V_{CCB} = 1.8V \pm 0.15V$		$V_{CCB} = 2.5V \pm 0.2V$		$V_{CCB} = 3.3V \pm 0.3V$		Units
			Typ	Min	Max	Min	Max	Min	Max	Min	Max	
t_{PD}	A	B	8	1.0	6.0	0.5	5.5	0.5	5.0	0.5	4.5	ns
	B	A	6	1.0	6.0	0.5	5.5	0.5	5.0	0.5	4.5	
$tsk(a)^{(1)}$	-		-	-	0.25	-	0.25	-	0.25	-	0.25	ns
$tsk(b)^{(1)}$	-		-	-	0.2	-	0.2	-	0.2	-	0.2	
f_{max} 10pF load	B	A	13	15	-	20	-	25	-	30	-	MHz
	A	B	16	20	-	20	-	22	-	24	-	

($V_{CCA} = 2.5V \pm 0.2V$, Over recommended free-air temperature range, unless otherwise noted.)

Parameter	From (Input)	To (Output)	$V_{CCB} = 1.2V$	$V_{CCB} = 1.5V \pm 0.1V$		$V_{CCB} = 1.8V \pm 0.15V$		$V_{CCB} = 2.5V \pm 0.2V$		$V_{CCB} = 3.3V \pm 0.3V$		Units
			Typ	Min	Max	Min	Max	Min	Max	Min	Max	
t_{PD}	A	B	8	1.0	5.5	0.5	5.0	0.5	4.5	0.5	4.0	ns
	B	A	6	1.0	5.5	0.5	5.0	0.5	4.5	0.5	4.0	
$tsk(a)^{(1)}$	-		-	-	0.25	-	0.25	-	0.25	-	0.25	ns
$tsk(b)^{(1)}$	-		-	-	0.2	-	0.2	-	0.2	-	0.2	
f_{max} 10pF load	B	A	13	15	-	22	-	35	-	40	-	MHz
	A	B	18	23	-	30	-	35	-	35	-	

($V_{CCA} = 3.3V \pm 0.3V$, Over recommended free-air temperature range, unless otherwise noted.)

Parameter	From (Input)	To (Output)	$V_{CCB} = 1.2V$	$V_{CCB} = 1.5V \pm 0.1V$		$V_{CCB} = 1.8V \pm 0.15V$		$V_{CCB} = 2.5V \pm 0.2V$		$V_{CCB} = 3.3V \pm 0.3V$		Units
			Typ	Min	Max	Min	Max	Min	Max	Min	Max	
t_{PD}	A	B	-	1.0	6.0	0.5	5.0	0.5	4.5	0.5	4.0	ns
	B	A	-	1.0	5.5	0.05	5.0	0.5	4.5	0.5	4.0	
$tsk(a)^{(1)}$	-		-	-	0.25	-	0.25	-	0.25	-	0.25	ns
$tsk(b)^{(1)}$	-		-	-	0.2	-	0.2	-	0.2	-	0.2	
f_{max} 10pF load	B	A	13	15	-	24	-	35	-	45	-	MHz
	A	B	15	25	-	30	-	40	-	45	-	

Note:

1. This is the skew between any two outputs of the same package, and switching in the same direction. For $tsk(a)$, Output 1 and Output 2 are any two outputs. For $tsk(b)$, Output 1 and Output 2 are in the same bank. These parameters are warranted but not production tested.

Operating Characteristics

(V_{CCA} and $V_{CCB} = 2.5V$; $T_A = 25\text{ }^\circ\text{C}$)

Parameter		Test Conditions	Typ	Units
$C_{pd}^{(1)}$ (V_{CCA})	Power Dissipation Capacitance A to B	Outputs Enabled	15	pF
		Outputs Disabled	2	
	Power Dissipation Capacitance B to A	Outputs Enabled	30	
		Outputs Disabled	10	
$C_{pd}^{(1)}$ (V_{CCB})	Power Dissipation Capacitance A to B	Outputs Enabled	30	pF
		Outputs Disabled	10	
	Power Dissipation Capacitance B to A	Outputs Enabled	15	
		Outputs Disabled	2	

Notes:

1. This parameter is specified under test mode conditions.

Parameter Measurement Information

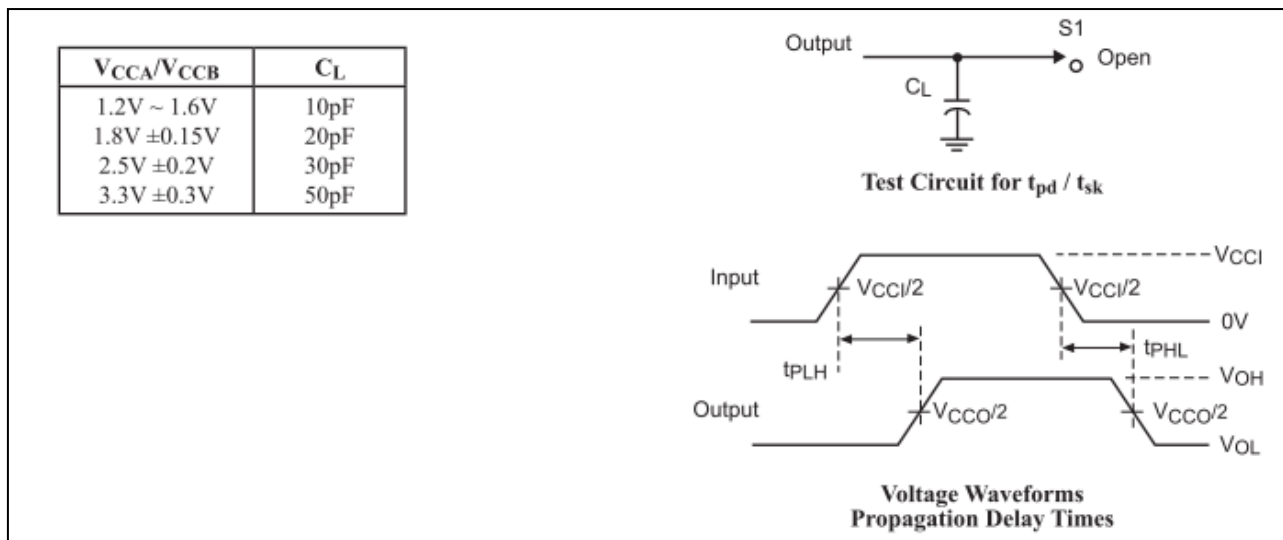

Figure 2. Load Circuit and Voltage Waveforms

Notes:

1. C_L includes probe and jig capacitance.
2. All input pulses are supplied by generators having the following characteristics: $PRR \leq 10\text{Mz}$, $Z_O = 50\Omega$, $t_r \leq 2.5\text{ns}$, $t_f \leq 2.5\text{ns}$.
3. The outputs are measured one at a time with one transition per measurement.
4. V_{CCI} defines the input port (V_{CCA} or V_{CCB}).
5. V_{CCO} defines the output port (V_{CCA} or V_{CCB}).

Mechanical Information

TQFN 3x6-32L

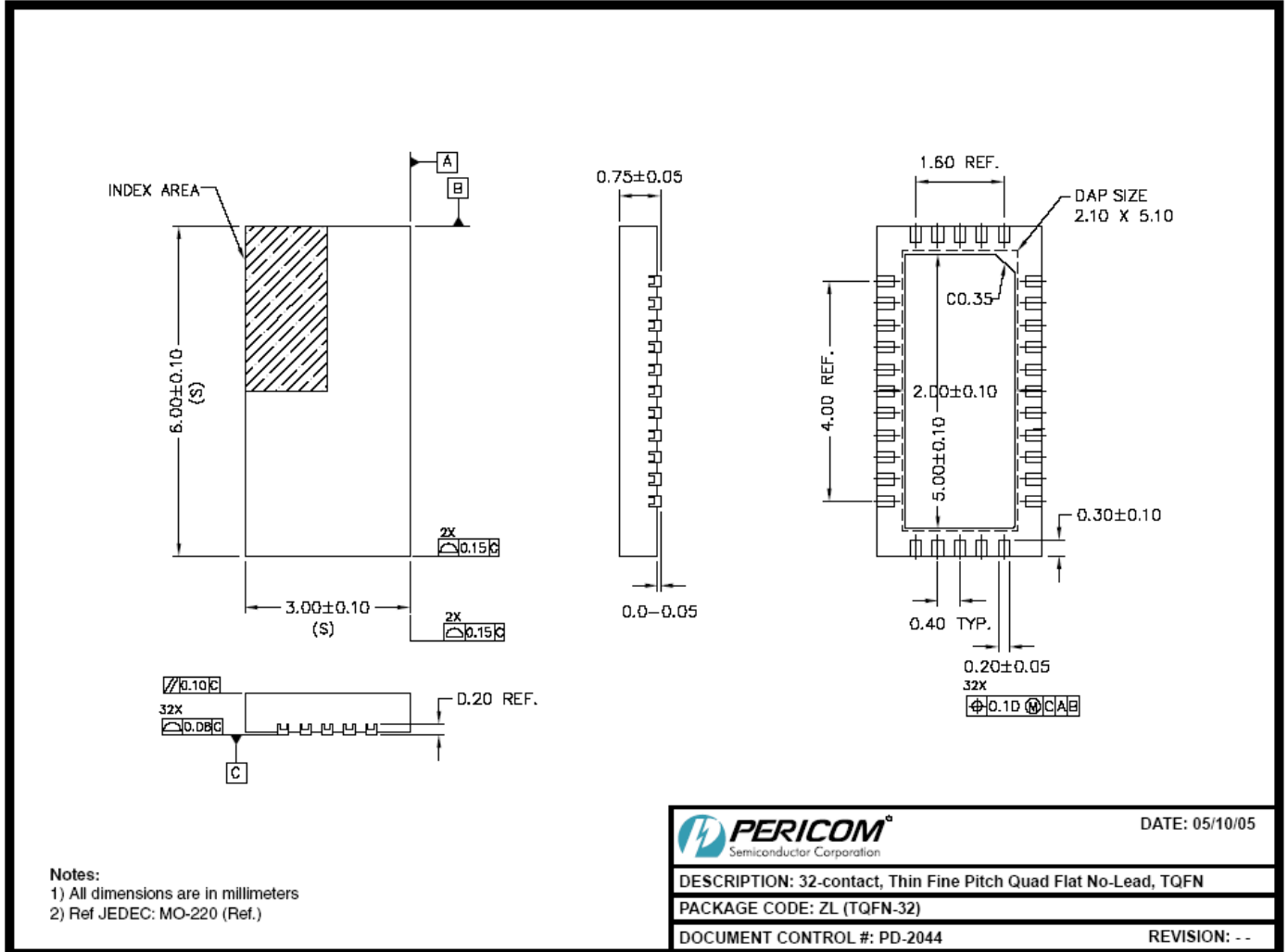

Ordering Information

Part No.	Package Code	Package
PI4ULS3V08MZLE	ZL	Lead free and Green 32-pin TQFN 3x6

Note:

- E = Pb-free
- Adding X Suffix= Tape/Reel

Pericom Semiconductor Corporation • 1-800-435-2336 • www.pericom.com

Pericom reserves the right to make changes to its products or specifications at any time, without notice, in order to improve design or performance and to supply the best possible product. Pericom does not assume any responsibility for use of any circuitry described other than the circuitry embodied in Pericom product. The company makes no representations that circuitry described herein is free from patent infringement or other rights, of Pericom.

X-ON Electronics

Largest Supplier of Electrical and Electronic Components

Click to view similar products for [Translation - Voltage Levels](#) category:

Click to view products by [Diodes Incorporated](#) manufacturer:

Other Similar products are found below :

[NLSX4373DMR2G](#) [NLSX5012MUTAG](#) [NLSX0102FCT2G](#) [NLSX4302EBMUTCG](#) [PCA9306FMUTAG](#) [MC100EPT622MNG](#)
[NLSX5011MUTCG](#) [NLV9306USG](#) [NLVSX4014MUTAG](#) [NLSV4T3144MUTAG](#) [NLVSX4373MUTAG](#) [MAX3371ELT+T](#)
[NLSX3013BFCT1G](#) [NLV7WBD3125USG](#) [NLSX3012DMR2G](#) [74AVCH1T45FZ4-7](#) [NLVSV1T244MUTBG](#) [74AVC1T45GS-Q100H](#)
[CLVC16T245MDGGREP](#) [MC10H124FNG](#) [CAVCB164245MDGGREP](#) [CD40109BPWR](#) [MC10H350FNG](#) [MC10H125FNG](#)
[MC100EPT21MNR4G](#) [MC100EP91DWG](#) [NLSV2T244MUTAG](#) [NLSX3013FCT1G](#) [NLSX5011AMX1TCG](#) [PCA9306USG](#)
[SN74GTL1655DGGR](#) [SN74AVCA406LZQSR](#) [NLSX4014DTR2G](#) [NLSX3018DTR2G](#) [LTC1045CN#PBF](#) [74AXP1T34GMH](#)
[74AXP1T34GNH](#) [PI4ULS3V204LE](#) [ADG3245BRUZ-REEL7](#) [ADG3123BRUZ](#) [ADG3245BRUZ](#) [ADG3308BCPZ-REEL](#) [ADG3233BRJZ-](#)
[REEL7](#) [ADG3233BRMZ](#) [ADG3242BRJZ-REEL7](#) [ADG3243BRJZ-REEL7](#) [ADG3245BCPZ](#) [ADG3247BRUZ](#) [ADG3247BRUZ-REEL](#)
[ADG3248BKSZ-REEL7](#)