

SOTiny™ Low Resistance, Low-Voltage Single-Supply SPDT Switch

Features

- CMOS Technology for Bus and Analog Applications
- Low On-Resistance: 8Ω at 3.0V
- Wide V+ Range: 1.65V to 6.0V
- Rail-to-Rail Signal Range
- Fast Transition Speed: 2ns at 5.0V
- High Off Isolation: -63dB @ 10MHz
- Break-Before-Make Switching
- High Bandwidth: 350MHz
- Extended Industrial Temperature Range:
-40°C to 85°C
- Packaging (Pb-free and Green):
-6-pin Small Compact SC70(C6)

Pin Assignment

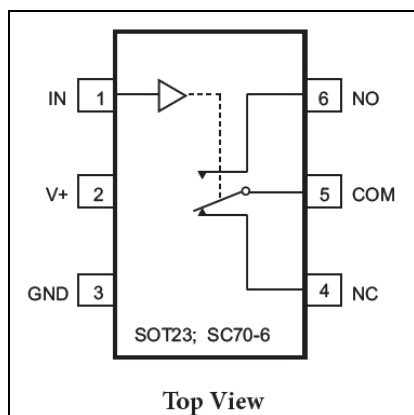

PI5A4599B

Description

The PI5A4599B is a high-bandwidth, fast single-pole double-throw (SPDT) CMOS switch. It can be used as an analog switch or as a low-delay bus switch. Specified over a wide operating power supply voltage range, 1.65V to 6.0V, the PI5A4599B has a maximum ON resistance of 12-ohms at 1.65V, 9-ohms at 2.3V & 6-ohms at 4.5V.

Break-before-make switching prevents both switches being enabled simultaneously. This eliminates signal disruption during switching.

The control input, IN, is independent of supply voltage.

Applications

- Cell Phones
- PDAs
- MP3 Players
- Portable Instrumentation
- Battery powered Communications
- Computer Peripherals

Pin Description

Pin No	Pin Name	Description
1	IN	Logic control
2	V+	Positive Power Supply
3	GND	Ground
4	NC	Data Port (Normally connected)
5	COM	Common Output/Data Port
6	NO	Data Port

Logic Function Table

Logic Inputs(IN)	NC	NO
0	ON	OFF
1	OFF	ON

Maximum Ratings

Storage Temperature.....	-65°C to +150°C
Ambient Temperature with Power Applied.....	-40°C to +85°C
Supply Voltage V+	-0.5V to +7.0V
DC Switch Voltage V _{IN}	-0.5V to V+ +0.5V
DC Input Voltage V _{INPUT}	-0.5V to +7.0V
DC Output Current V _{OUT}	128mA
DC V+ or Ground Current I+ /I _{GND}	±100mA
Junction Temperature under Bias (T _J)	150°C
Junction Lead Temperature (T _L) (Soldering, 10 seconds)	260°C
Power Dissipation (P _D) @ +85°C	180mW

Note:

Stresses greater than those listed under MAXIMUM RATINGS may cause permanent damage to the device. This is a stress rating only and functional operation of the device at these or any other conditions above those indicated in the operational sections of this specification is not implied. Exposure to absolute maximum rating conditions for extended periods may affect reliability.

Recommended Operating Conditions

Symbol	Parameter	Conditions	Min.	Typ.	Max.	Unit
V+	Operating Voltage	-	1.65	-	6.0	V
V _{IN}	Control Input Voltage	-	0	-	V+	V
V _S	Switch Input Voltage	-	0	-	V+	V
V _{OUT}	Output Voltage	-	0	-	V+	V
T _A	Operating Temperature	-	-40	25	85	°C
t _r , t _f	Input Rise and Fall Time	Control Input V+ = 2.3V to 3.6V	0	-	10	ns/V
		Control Input V+ = 4.5V to 6.0V	0	-	5	ns/V

Note: Control input must be held HIGH or LOW; it must not float.

DC Electrical Characteristics

 (T_A = -40°C to 85°C, unless otherwise noted.)

Parameter	Description	Test Conditions	Temperature (T _A :°C)	Min.	Typ.	Max.	Units
V _{IAR}	Analog Input Signal Range	V+	-40°C to 85°C	0	-	V+	V
R _{ON}	ON Resistance ⁽¹⁾	V+=4.5V, I _O = 30mA, V _{INPUT} = 0V	25°C	-	4	6	Ω
		V+=4.5V, I _O =-30mA, V _{INPUT} =2.4V		-	5	8	
		V+=4.5V, I _O = -30mA, V _{INPUT} =4.5V		-	7	11	
		V+=4.5V, I _O = 30mA, V _{INPUT} = 0V	-40°C to 85°C	-	-	6	
		V+=4.5V, I _O = -30mA, V _{INPUT} =2.4V		-	-	8	
		V+=4.5V, I _O = -30mA, V _{INPUT} =4.5V		-	-	11	
		V+=3.0V, I _O = 24mA, V _{INPUT} = 0V	25°C	-	5	8	
		V+=3.0V, I _O = -24mA, V _{INPUT} =3.0V		-	10	15	
		V+=3.0V, I _O = 24mA, V _{INPUT} =0V		-40°C to 85°C	-	-	
		V+=3.0V, I _O =-24mA, V _{INPUT} =3.0V	-		-	15	
		V+=2.3V, I _O = 8mA, V _{INPUT} = 0V	25°C		-	6	
		V+=2.3V, I _O = -8mA, V _{INPUT} =2.3V		-	13	20	
		V+=2.3V, I _O = 8mA, V _{INPUT} = 0V		-40°C to 85°C	-	-	
		V+=2.3V, I _O =-8mA, V _{INPUT} =2.3V	-		-	20	
		V+=1.65V, I _O = 4mA, V _{INPUT} = 0V	25°C		-	8	
		V+=1.65V, I _O =-4mA, V _{INPUT} =1.65V		-	20	30	
		V+=1.65V, I _O = 4mA, V _{INPUT} = 0V		-40°C to 85°C	-	-	
		V+=1.65V, I _O =-4mA, V _{INPUT} =1.65V	-		-	25	
ΔR _{ON}	ON Resistance Match Between Channels ^(1,2,3)	V+=4.5V, I _A =-30mA, V _{INPUT} =3.15V	25°C		-	0.15	-
		V+=3.0V, I _A =-24mA, V _{INPUT} = 2.1V		-	0.2	-	
		V+=2.3V, I _A = -8mA, V _{INPUT} = 1.6V		-	0.3	-	
		V+=1.65V, I _A =-4mA, V _{INPUT} =1.15V		-	0.5	-	
R _{ONF}	ON Resistance Flatness ^(1,2,4)	V+=5.0V, I _A = -30mA, 0 ≤ V _{INPUT} ≤ V+	25°C	-	4.6	-	Ω
		V+=3.3V, I _A = -24mA, 0 ≤ V _{INPUT} ≤ V+		-	7	-	
		V+=2.5V, I _A = -8mA, 0 ≤ V _{INPUT} ≤ V+		-	15	-	
		V+=1.8V, I _A = -4mA, 0 ≤ V _{INPUT} ≤ V+		-	77	-	
V _{IH}	Input High Voltage (Logic High Level)	V+=1.65V	-40°C to 85°C	1	-	-	V
		V+ = 2.3V		1.2	-	-	
		V+ = 3V		1.3	-	-	
		V+ = 4.2V		1.5	-	-	
		V+ = 5.5V		1.8	-	-	
V _{IL}	Input Low Voltage (Logic Low Level)	V+=1.65V	-40°C to 85°C	-	-	0.4	V
		V+ = 2.3V		-	-	0.6	
		V+ = 3V		-	-	0.8	
		V+ = 4.2V		-	-	1	
		V+ = 5.5V		-	-	1.2	
I _{LKC}	Input Leakage Current	0 ≤ V _{IN} ≤ 5.5V, V+ = 0V to 5.5V	25°C	-	-	±0.1	μA
			-40°C to 85°C	-	-	±1.0	
I _{OFF}	OFF State Leakage Current	0 ≤ V _{IN} ≤ 5.5V, V+ = 1.65V to 5.5V	25°C	-	-	±0.1	μA
			-40°C to 85°C	-	-	±10	
I+	Quiescent Supply Current	All channels ON or OFF, V _{IN} = V+ or GND, I _{OUT} = 0, V+ = 5.5V V	25°C	-	-	1	μA
			-40°C to 85°C	-	-	5	

Notes:

- Measured by voltage drop between COM and NC/NO pins at the indicated current through the device. ON resistance is determined by the lower of the voltages on two ports (COM or NC/NO).
- Parameter is characterized but not tested in production.
- ΔR_{ON} = R_{ON} max – R_{ON} min. measured at identical V+, temperature and voltage levels.
- Flatness is defined as difference between maximum and minimum value of ON resistance over the specified range of conditions. Guaranteed by design.

Capacitance ⁽¹⁾

($T_A = 25^\circ\text{C}$, unless otherwise noted.)

Symbol	Parameter	Test Conditions	Min.	Typ.	Max.	Units
C_{IN}	Control Input	$V_+ = 5.0\text{V}$, $f = 1\text{ MHz}$ ⁽¹⁾	-	2.5	-	pF
C_{OFF}	NC/NO Port, Switch OFF		-	5.0	-	
$C_{COM ON}$	COM Port, Switch ON		-	15.0	-	

Notes:

1. Capacitance is characterized but not tested in production

Switch and AC Characteristics ⁽¹⁾

Parameter	Description	Test Conditions	Supply Voltage	Temperature (T_A : $^\circ\text{C}$)	Min.	Typ.	Max.	Units
t_{ON}	Turn-On Time	$R_L = 100\Omega$, $C_L = 35\text{pF}$, <i>See Test Circuit Figure 1.</i>	$V_+ = 3.3\text{V}$, V_{NO} or $V_{NO} = 1.5\text{V}$, $V_{IL} = 1.5\text{V}$,	$+25^\circ\text{C}$	-	5	25	ns
			$V_+ = 5.0\text{V}$, V_{NO} or $V_{NO} = 3\text{V}$, $V_{IL} = 3\text{V}$,		-	3	15	
t_{OFF}	Turn-Off Time	$R_L = 100\Omega$, $C_L = 35\text{pF}$, <i>See Test Circuit Figure 1.</i>	$V_+ = 3.3\text{V}$, V_{NO} or $V_{NO} = 1.5\text{V}$, $V_{IL} = 1.5\text{V}$,	$+25^\circ\text{C}$	-	2	12	
			$V_+ = 5.0\text{V}$, V_{NO} or $V_{NO} = 3\text{V}$, $V_{IL} = 3\text{V}$,		-	1.5	7	
t_{BM}	Break Before Make Time	<i>See Test Circuit Figure 2.</i>	$V_+ = 1.65\text{V}$ to 1.95V	-40 to 85°C	0.5	-	-	
			$V_+ = 2.3\text{V}$ to 2.7V		0.5	-	-	
			$V_+ = 3.0\text{V}$ to 3.6V		0.5	-	-	
			$V_+ = 4.5\text{V}$ to 5.5V		0.5	-	-	
Q	Charge Injection	$C_L = 0.1\text{nF}$, $V_{GEN} = 0\text{V}$, $R_{GEN} = 0\Omega$. <i>See Test Circuit Figure 3.</i>	$V_+ = 5.0\text{V}$	25°C	-	5	-	pC
			$V_+ = 3.3\text{V}$		-	4	-	
OIRR	Off Isolation	$R_L = 50\Omega$, $V_{GEN} = 0\text{V}$, $R_{GEN} = 0\Omega$, $f = 1\text{MHz}$. ⁽³⁾ <i>See test circuit 5</i>	$V_+ = 1.65\text{V}$ to 5.5V	25°C	-	-82	-	dB
X_{TALK}	Crosstalk Isolation	$R_L = 50\Omega$, $V_{GEN} = 0\text{V}$, $R_{GEN} = 0\Omega$, $f = 1\text{MHz}$.	$V_+ = 1.65\text{V}$ to 5.5V	25°C	-	-82	-	
f_{3dB}	-3dB Bandwidth	<i>See Test Circuit Figure 8</i>	$V_+ = 1.65\text{V}$ to 5.5V	25°C	-	350	-	MHz

Notes:

- Guaranteed by design.
- The device contributes no other propagation delay other than the RC delay of the switch ON resistance and the 50pF load capacitance, when driven by an ideal voltage source with zero output impedance.
- Off Isolation = $20 \text{ Log}_{10} [V_{NC} \text{ (or } V_{NO})/V_{COM}]$ and is measured in dB.
- Crosstalk Isolation = $20 \text{ Log}_{10} [V_{NO}/V_{NC}]$ and is measured in dB.

Test Circuits and Timing Diagrams

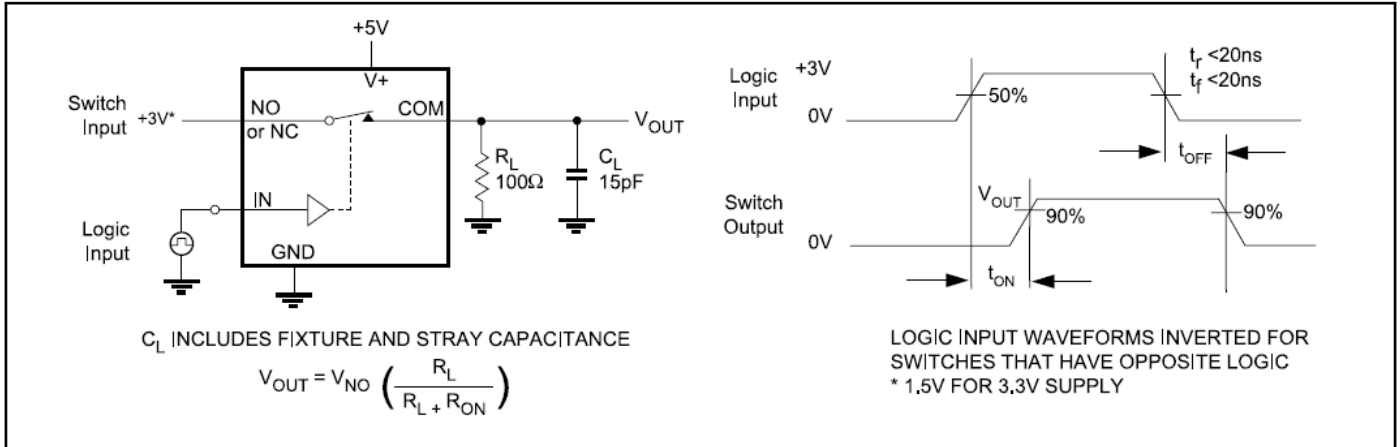

Figure 1. Switching Time

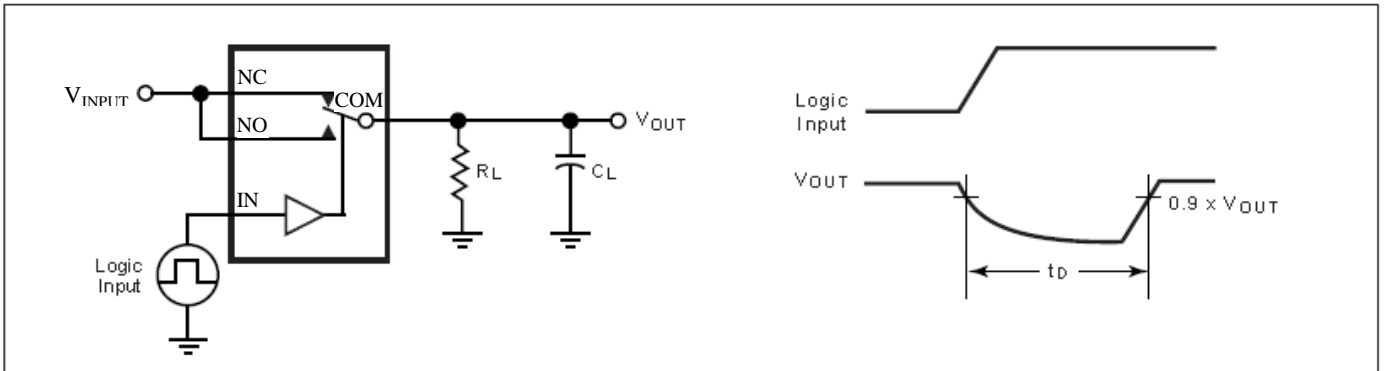

Figure 2. Break Before Make Interval Timing

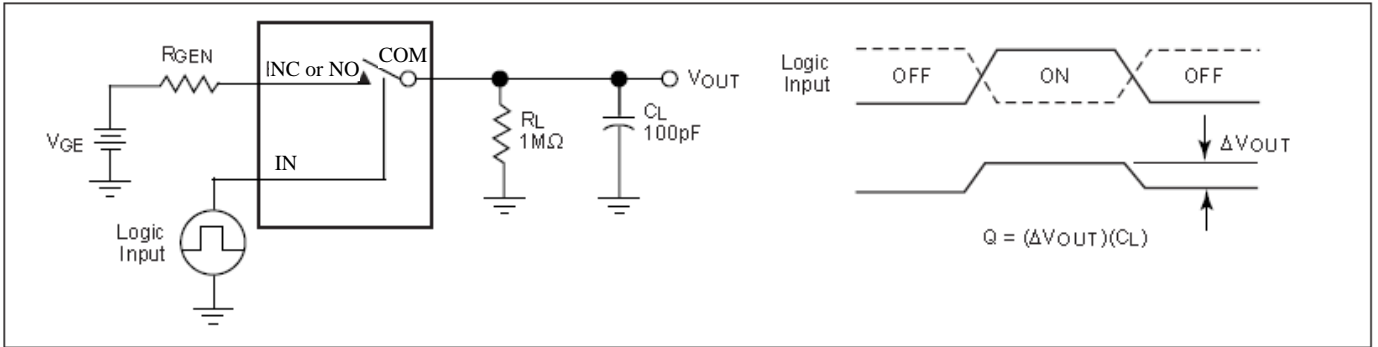

Figure 3. Charge Injection Test

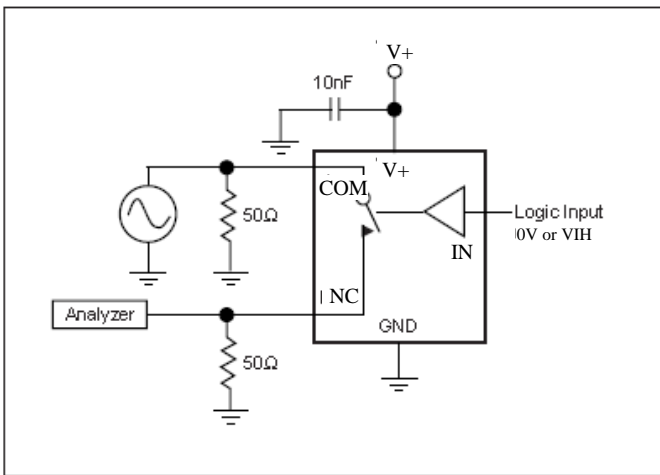

Figure 4. Off Isolation

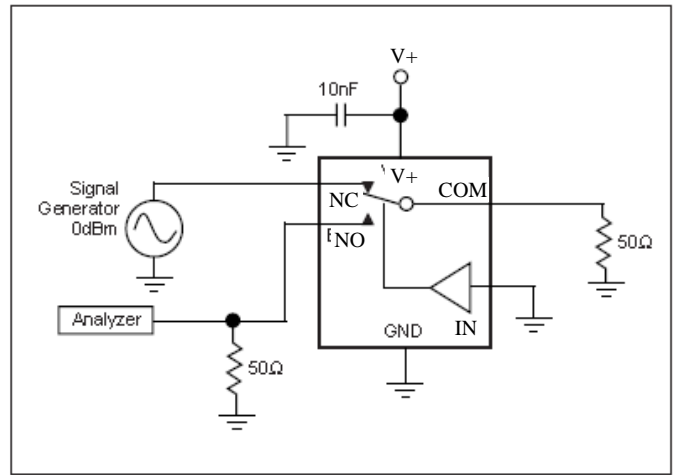

Figure 5. Crosstalk

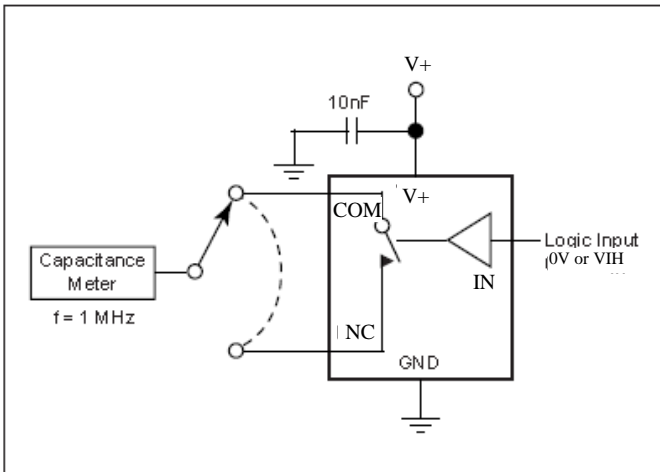

Figure 6. Channel Off Capacitance

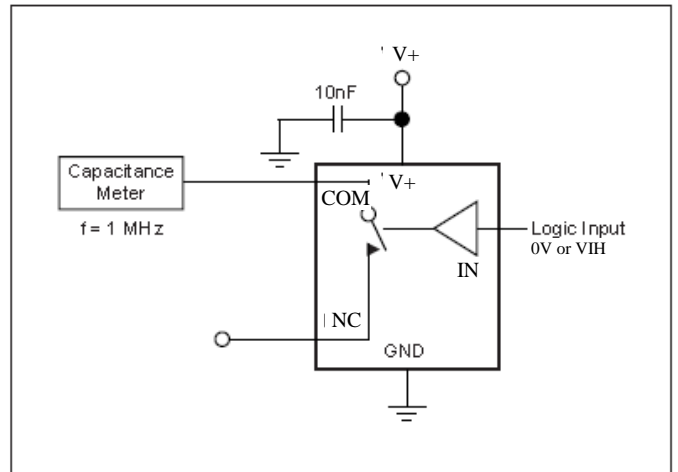

Figure 7. Channel On Capacitance

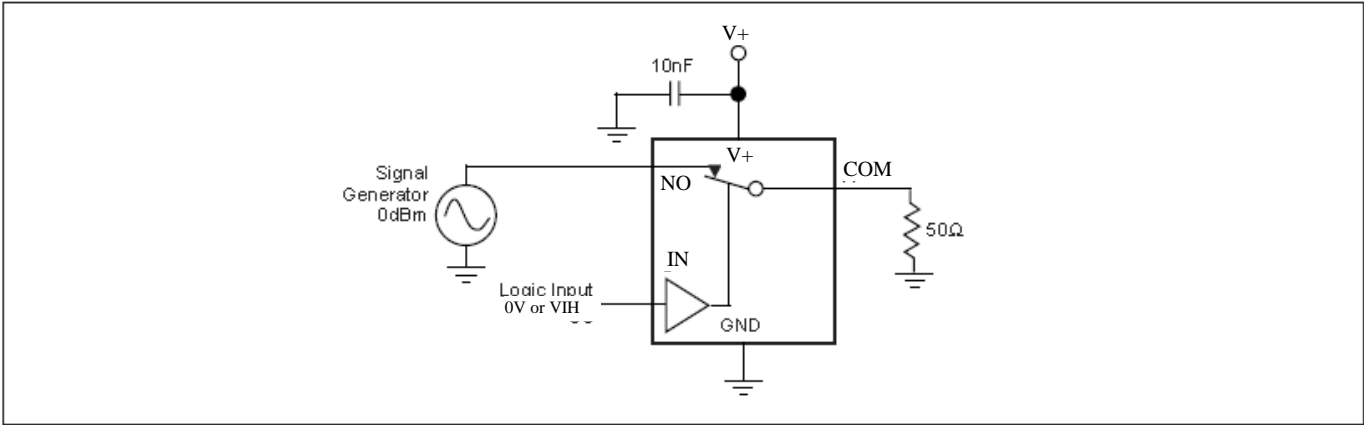

Figure 8. Bandwidth

Mechanical Information
C-6 (SC70)

PKG. DIMENSIONS(MM)		
SYMBOL	Min	Max
A	-	1.10
A1	0.00	0.10
A2	0.70	1.00
b	0.15	0.40
c	0.08	0.22
D	1.80	2.20
E	1.10	1.40
E1	1.80	2.40
e	0.65 BSC	
L	0.26	0.46
θ	0°	8°

Notes:

1. Comply with MO-203C/AB, except b Max, D Min and D Max.
2. PACKAGE OUTLINE DIMENSIONS DO NOT INCLUDE MOLD FLASH AND METAL BURR

PERICOM Enabling Serial Connectivity		DATE: 03/29/16
DESCRIPTION: 6-Pin, SOT363 (SC70)		
PACKAGE CODE: C (C6)		
DOCUMENT CONTROL#: PD-1902	REVISION: B	

16-0078

For latest package info.

please check: <http://www.diodes.com/design/support/packaging/pericom-packaging/packaging-mechanicals-and-thermal-characteristics/>

Ordering Information

Part Number	Package Code	Package	Top Marking
PI5A4599BCEX	C	6-Pin, SOT363 (SC70)	nK

Notes:

- Thermal characteristics can be found on the company web site at www.diodes.com/design/support/packaging/
- E = Pb-free and Green
- X suffix = Tape/Reel

IMPORTANT NOTICE

DIODES INCORPORATED MAKES NO WARRANTY OF ANY KIND, EXPRESS OR IMPLIED, WITH REGARDS TO THIS DOCUMENT, INCLUDING, BUT NOT LIMITED TO, THE IMPLIED WARRANTIES OF MERCHANTABILITY AND FITNESS FOR A PARTICULAR PURPOSE (AND THEIR EQUIVALENTS UNDER THE LAWS OF ANY JURISDICTION).

Diodes Incorporated and its subsidiaries reserve the right to make modifications, enhancements, improvements, corrections or other changes without further notice to this document and any product described herein. Diodes Incorporated does not assume any liability arising out of the application or use of this document or any product described herein; neither does Diodes Incorporated convey any license under its patent or trademark rights, nor the rights of others. Any Customer or user of this document or products described herein in such applications shall assume all risks of such use and will agree to hold Diodes Incorporated and all the companies whose products are represented on Diodes Incorporated website, harmless against all damages.

Diodes Incorporated does not warrant or accept any liability whatsoever in respect of any products purchased through unauthorized sales channel.

Should Customers purchase or use Diodes Incorporated products for any unintended or unauthorized application, Customers shall indemnify and hold Diodes Incorporated and its representatives harmless against all claims, damages, expenses, and attorney fees arising out of, directly or indirectly, any claim of personal injury or death associated with such unintended or unauthorized application.

Products described herein may be covered by one or more United States, international or foreign patents pending. Product names and markings noted herein may also be covered by one or more United States, international or foreign trademarks.

This document is written in English but may be translated into multiple languages for reference. Only the English version of this document is the final and determinative format released by Diodes Incorporated.

LIFE SUPPORT

Diodes Incorporated products are specifically not authorized for use as critical components in life support devices or systems without the express written approval of the Chief Executive Officer of Diodes Incorporated. As used herein:

A. Life support devices or systems are devices or systems which:

1. are intended to implant into the body, or
2. support or sustain life and whose failure to perform when properly used in accordance with instructions for use provided in the labeling can be reasonably expected to result in significant injury to the user.

B. A critical component is any component in a life support device or system whose failure to perform can be reasonably expected to cause the failure of the life support device or to affect its safety or effectiveness.

Customers represent that they have all necessary expertise in the safety and regulatory ramifications of their life support devices or systems, and acknowledge and agree that they are solely responsible for all legal, regulatory and safety-related requirements concerning their products and any use of Diodes Incorporated products in such safety-critical, life support devices or systems, notwithstanding any devices- or systems-related information or support that may be provided by Diodes Incorporated. Further, Customers must fully indemnify Diodes Incorporated and its representatives against any damages arising out of the use of Diodes Incorporated products in such safety-critical, life support devices or systems.

Copyright © 2016, Diodes Incorporated
www.diodes.com

X-ON Electronics

Largest Supplier of Electrical and Electronic Components

Click to view similar products for [Analogue Switch ICs](#) category:

Click to view products by [Diodes Incorporated](#) manufacturer:

Other Similar products are found below :

[FSA3051TMX](#) [NLAS4684FCTCG](#) [NLAS5223BLMNR2G](#) [NLVAS4599DTT1G](#) [NLX2G66DMUTCG](#) [425541DB](#) [425528R](#) [099044FB](#)
[NLAS5123MNR2G](#) [PI5A4157CEX](#) [NLAS4717EPFCT1G](#) [PI5A3167CCEX](#) [SLAS3158MNR2G](#) [PI5A392AQE](#) [PI5A4157ZUEX](#)
[PI5A3166TAEX](#) [XS3A1T3157GMX](#) [TC4066BP\(N,F\)](#) [DG302BDJ-E3](#) [PI5A100QEX](#) [HV2301FG-G](#) [RS2117YUTQK10](#) [RS2118YUTQK10](#)
[RS2227XUTQK10](#) [ADG452BRZ-REEL7](#) [MAX391CPE+](#) [MAX4730EXT+T](#) [MAX314CPE+](#) [BU4066BCFV-E2](#) [MAX313CPE+](#)
[BU4S66G2-TR](#) [NLASB3157MTR2G](#) [TS3A4751PWR](#) [NLAST4599DFT2G](#) [NLAST4599DTT1G](#) [DG419LDY+T](#) [DG300BDJ-E3](#)
[DG2503DB-T2-GE1](#) [TC4W53FU\(TE12L,F\)](#) [DG3257DN-T1-GE4](#) [ADG1611BRUZ-REEL7](#) [LTC201ACN#PBF](#) [74LV4066DB,118](#)
[ISL43410IUZ](#) [FSA2275AUMX](#) [DIO1500WL12](#) [ADG742BKSZ-REEL7](#) [DIO1269LP10](#) [DG201HSDJ-E3](#) [DG307BDJ-E3](#)