

Low On-Resistance Wideband/Video Dual 4-Channel Mux/DeMux

Features

- High-performance, low-cost solution to switch between video sources
- Wide bandwidth: 150 MHz
- Low On-Resistance: 3Ω
- Low crosstalk at 10 MHz: -58dB
- Ultra-low quiescent power ($0.1\mu\text{A}$ typical)
- Single supply operation: $+5.0\text{V}$
- Fast switching: 10ns
- High-current output: 100mA
- Functionally equivalent to QS4A210
- Packaging (Pb-free & Green):
 - 16-pin 150-mil wide plastic QSOP (Q)

Block Diagram

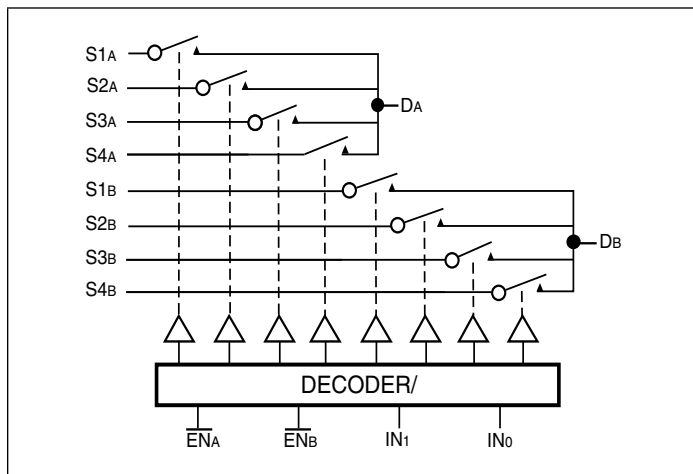

Description

Pericom Semiconductor's PI5V331 is a true bi directional Dual 4-channel multiplexer/demultiplexer that is recommended for both S-Video or composite video switching applications. The switch can be driven from a current output RAMDAC or voltage output composite video source.

Low On-resistance and wide bandwidth make it ideal for video and other applications. Also this device has exceptionally high current capability which is far greater than most analog switches offered today. A single 5V supply is all that is required for operation.

The PI5V331 offers a high-performance, low-cost solution to switch between video sources.

Pin Configuration (16-Pin QSOP)

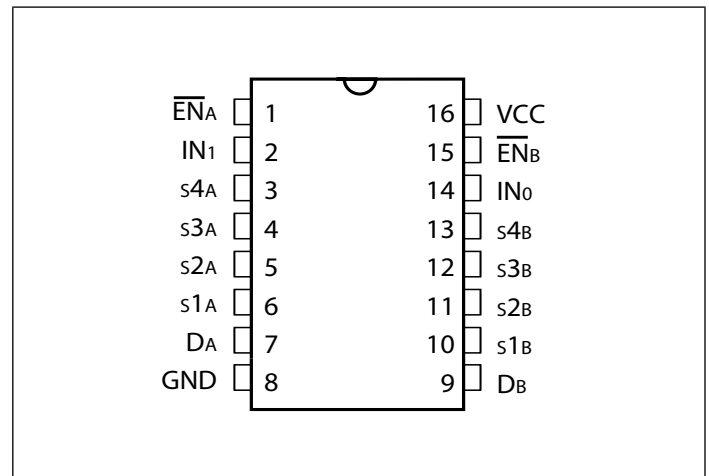

Truth Table

ENA	ENB	IN1	IN0	ON Switch
1	X	X	X	Disabled A
X	1	X	X	Disabled B
0	0	0	X	S1A - DA, S1B - DB
0	0	0	0	S2A - DA, S2B - DB
0	0	1	1	S3A - DA, S3B - DB
0	0	1	X	S4A - DA, S4B - DB

Pinout Table

Pin Name	Description
S1A, S2A, S3A, S4A, S1B, S2B, S3B, S4B	Analog Video I/O (Usually Inputs)
S0, S1	Select Input
ENA, ENB	Enable
DA, DB	Analog Video I/O (Usually Outputs)
GND	Ground
VCC	Power

Absolute Maximum Ratings (Over operating free-air temperature range)

Parameter	Min.	Max.	Units
Storage temperature	-65	150	°C
Ambient Temperature with Power Applied	-40	85	
Supply Voltage to Ground Potential (Inputs & V _{CC} Only)	-0.5	7.0	V
Supply Voltage to Ground Potential (Outputs & D/O Only)	-0.5	7.0	
DC Input Voltage	-0.5	7.0	
DC Output Current	-	120	mA
Power Dissipation	-	500	mW

Stress beyond those listed under “Absolute Maximum Ratings” may cause permanent damage to the device.

DC Electrical Characteristics (Over the Operating Range, T_A = -40°C to +85°C, V_{CC} = 5V ±5%)

Parameters	Description	Test Conditions ⁽¹⁾	Min	Typ ⁽²⁾	Max	Units
V _{ANALOG}	Analog Signal Range		0		2.0	V
V _{IH}	Input HIGH Voltage	Guaranteed Logic HIGH level	2.0			
V _{IL}	Input LOW Voltage	Guaranteed Logic LOW Level	-0.5		0.8	
I _{IH}	Input HIGH Current	V _{CC} = Max., V _{IN} = V _{CC}			±1	µA
I _{IL}	Input LOW Current	V _{CC} = Max., V _{IN} = GND			±1	
I _O	Analog Output Leakage Current	0 ≤ S1, S2, or D ≤ V _{CC} , Switch OFF			±1	
V _{IK}	Clamp Diode Voltage	V _{CC} = Min., I _{IN} = -18mA		-0.7	-1.2	V
I _{OS}	Short Circuit Current ⁽³⁾	S1, S2, D = 0V V _{CC}	100			mA
V _H	Input Hysteresis at Control Pins			150		mV
R _{ON}	Switch On-Resistance	V _{CC} = MIN., V _{OUT} = 0.975V R _L = 75Ω, I _{ON} = 13 mA		3	7	Ω
		V _{CC} = MIN., V _{OUT} = 1.95V R _L = 75Ω, I _{ON} = 26 mA		7	10	

Notes:

1. For Max. or Min. conditions, use appropriate value specified under Electrical Characteristics for the applicable device type.
2. Typical values are at V_{CC} = 5.0V, T_A = 25°C ambient and maximum loading.
3. Not more than one output should be shorted at one time. Duration of the test should not exceed one second.
4. Measured by the voltage drop between S1, S2, and D I/O pins at indicated current through the switch. On-Resistance is determined by the lower of the voltages on the S1, S2, and D I/O pins.

Dynamic Characteristics (Over the Operating Range, $T_A = -40^{\circ}\text{C}$ to $+85^{\circ}\text{C}$, $V_{CC} = 5V \pm 5\%$)

Parameters	Description	Test Conditions ⁽¹⁾	Min	Typ	Max	Units
T_{ON}	Turn On Time	$R_L = 70\Omega$, $C_L = 20\text{PF}$, See Fig. 2		2.5	5	ns
T_{OFF}	Turn Off Time	$R_L = 70\Omega$, $C_L = 20\text{PF}$, See Fig. 2		1.1	5	
$BW^{(1)}$	-3dB Bandwidth	$R_L = 150\Omega$, See Fig. 3	150			MHz
X_{TALK}	Crosstalk	$R_{IN} = 10\Omega$; $R_L = 150\Omega$, 10MHz, See Fig. 3		-58		dB
D_G	Differential Gain	$R_L = 150\Omega$, $f = 3.58\text{ MHz}$, See Fig. 1		0.64		%
D_P	Differential Phase	$R_L = 150\Omega$, $f = 3.58\text{ MHz}$, See Fig. 1		0.27		Deg.
$C_{IN}^{(1)}$	Input/Enable Capacitance	$V_{IN} = 0V$, $f = 1\text{ MHz}$			6	pF
$C_{OFF}^{(1)}$	Capacitance, Switch Off	$V_{IN} = 0V$, $f = 1\text{ MHz}$			6	
$C_{ON}^{(1)}$	Capacitance, Switch On	$V_{IN} = 0V$, $f = 1\text{ MHz}$			20	
O_{IRR}	Off Isolation	$R_L = 150\Omega$, 10MHz, See Fig 3		-38		dB

Notes:

1. This parameter is determined by device characterization but is not production tested.

Power Supply Characteristics

Parameters	Description	Test Conditions ⁽¹⁾		Min	Typ ⁽²⁾	Max	Units
I_{CC}	Quiescent Power Supply Current	$V_{CC} = \text{Max.}$	$IN = \text{GND or } V_{CC}$		0.1	3.0	μA
ΔI_{CC}	Supply Current per Input @ TTL HIGH	$V_{CC} = \text{Max.}$	$IN = 3.4V^{(3)}$			2.5	mA
I_{CCD}	Supply Current per Input per MHz ⁽⁴⁾	$V_{CC} = \text{Max.}$, S1, S2 and D Pins Open $\overline{EN} = \text{GND}$ Control Input Toggling 50% Duty Cycle				0.25	mA/ MHz

Notes:

- For Max. or Min. conditions, use appropriate value specified under Electrical Characteristics for the applicable device.
- Typical values are at $V_{CC} = 5.0V$, $+25^{\circ}\text{C}$ ambient and maximum loading.
- Per TTL driven input ($V_{IN} = 3.4V$, control inputs only); S1, S2, and D pins do not contribute to I_{CC} .
- This current applies to the control inputs only and represent the current required to switch internal capacitance at the specified frequency. The S1, S2, and D I/O pins generate no significant AC or DC currents as they transition. This parameter is not tested, but is guaranteed by design.

Definitions

Parameters	Description
T_{ON}	Resistance between source and drain with switch in the ON state.
I_O	Output leakage current measured at S1, S2, and D with the switch OFF.
V_{IN}	Digital voltage at the IN pin that selects between S1 and S2 analog inputs.
V_{EN}	A voltage that ENABLES the chip.
C_{IN}	Capacitance at the digital inputs.
C_{OFF}	Capacitance at analog I/O (S1, S2, D) with switch OFF.
C_{ON}	Capacitance at analog I/O (S1, S2, D) with switch ON.
V_{IH}	Minimum input voltage for logic HIGH.
V_{IL}	Minimum input voltage for logic LOW.
I_{IH} (I_{IL})	Input current of the digital input.
I_{OS}	Minimum short circuit current for S1, S2 and D.
t_{ON}	Propagation delay measured between 50% of the digital input to 90% of the analog output when switch is turned ON. The peak analog voltage is 0.714V.
t_{OFF}	Propagation delay measured between 50% of the digital input to 90% of the analog output when switch is turned OFF. The peak analog voltage is 0.714V.
B_W	Frequency response of the switch in the ON state measured at 3dB down.
X_{TALK}	Is an unwanted signal coupled from channel to channel. Measured in -dB. $X_{TALK} = 20 \text{ LOG } V_{OUT}/V_{IN}$. This is non-adjacent crosstalk.
D_G	Differential gain is the difference measurement between two bias levels, for instance analog input signals of 0V to 0.714V.
D_P	Differential phase is the difference measurement between two bias levels, for instance analog input signals of 0V to 0.714V.
O_{IRR}	Off isolation is the resistance (measured in -dB) between the input and output with the switch off (NO).

Test Circuits

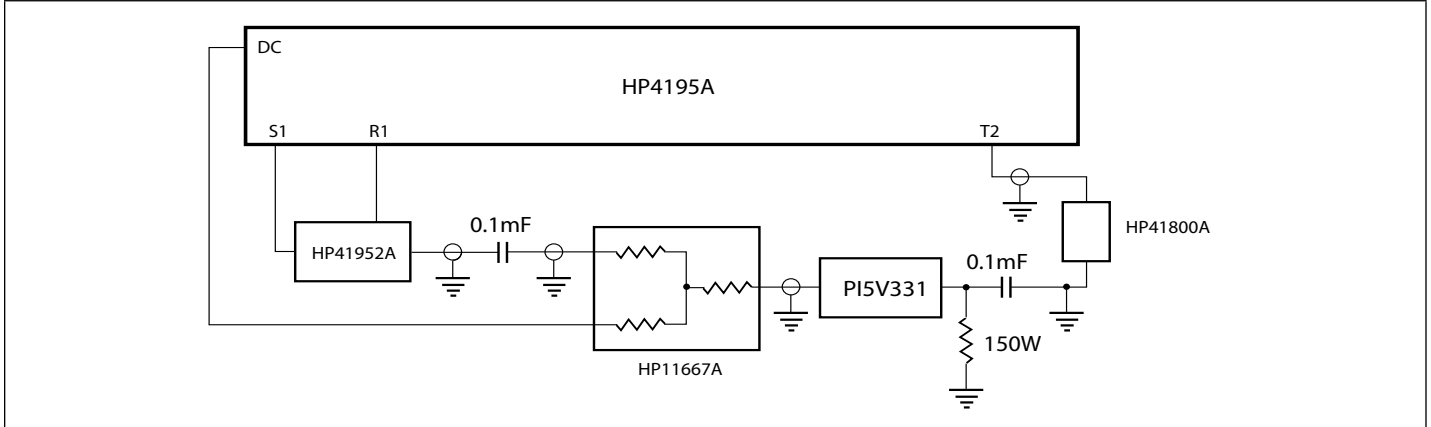

Figure 1. Differential Gain/Phase

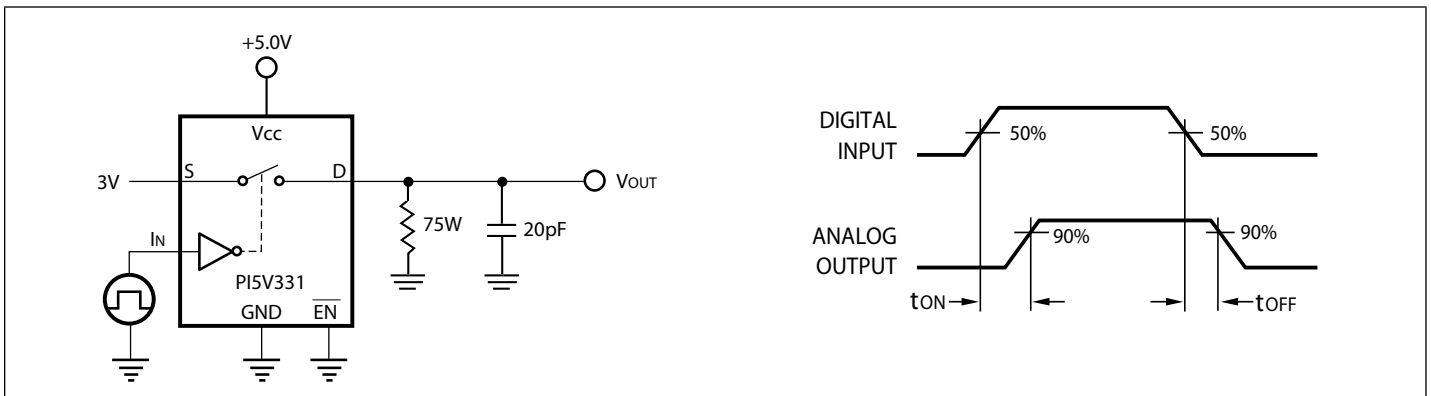

Figure 2. Switching Time

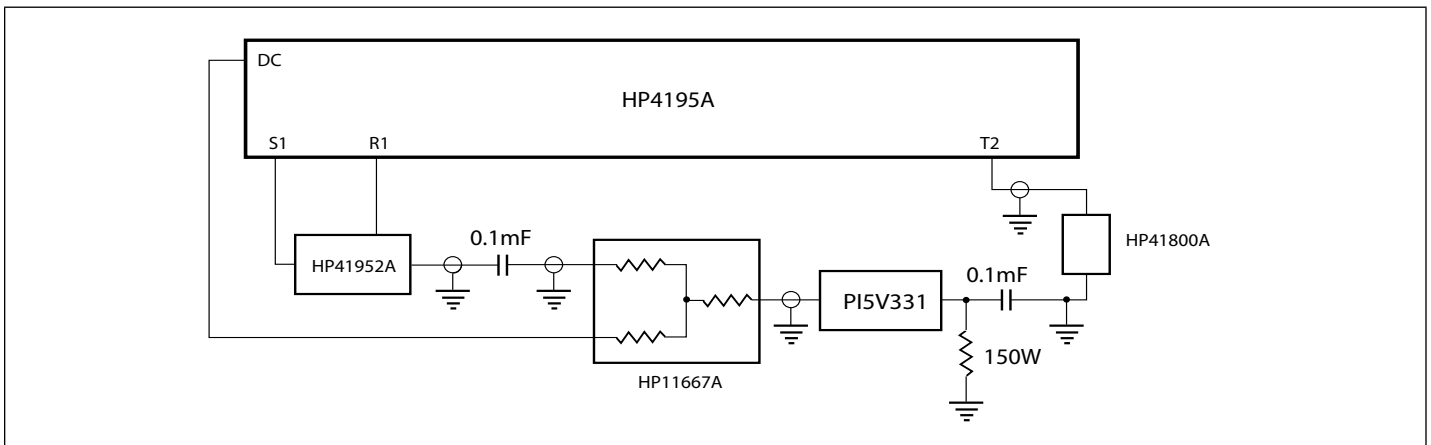
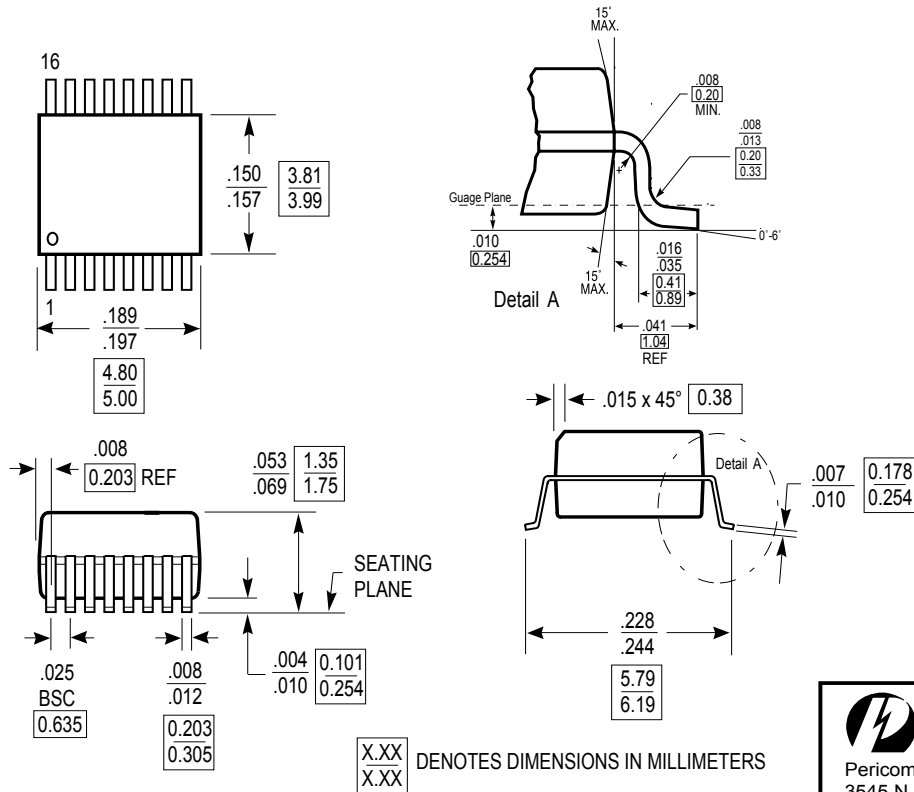

Figure 3. Gain/Phase, Crosstalk, Off-Isolation

Packaging Mechanical: 16-Pin QSOP (Q)

DOCUMENT CONTROL NO.
 PD - 1201

REVISION: G
 DATE: 11/07/07



- Note:
 1) Controlling dimensions in inches.
 2) Ref: JEDEC MO-137B/AB.
 3) Dimensions do not include mold flash, protrusions or gate burrs



Pericom Semiconductor Corporation
 3545 N. 1st Street, San Jose, CA 95134
 1-800-435-2335 • www.pericom.com

DESCRIPTION: 16-Pin 150-Mil Wide QSOP

PACKAGE CODE: Q

Ordering Information

Ordering Code	Package Code	Package Type
PI5V331QE	Q	Pb-free & Green, 16-pin 150-mil wide QSOP

1. Thermal characteristics can be found on the company web site at www.pericom.com/packaging/
2. "E" denotes Pb-free and Green
3. Adding an "X" at the end of the ordering code denotes tape and reel packaging

X-ON Electronics

Largest Supplier of Electrical and Electronic Components

Click to view similar products for [Multiplexer Switch ICs](#) category:

Click to view products by [Diodes Incorporated](#) manufacturer:

Other Similar products are found below :

[NLV74HC4066ADR2G](#) [HEF4051BP](#) [MC74HC4067ADTG](#) [DG508AAK/883B](#) [NLV14051BDG](#) [016400E](#) [PI3V512QE](#) [7705201EC](#)
[PI2SSD3212NCE](#) [PI3L100QE](#) [NLAS3257CMX2TCG](#) [PI5A3157BC6EX](#) [PI3V512QEX](#) [PI3DBS16213ZLEX](#) [PI3DBS16415ZHEX](#)
[PS509LEX](#) [MUX36S16IRSNR](#) [74LVC1G3157GM-Q10X](#) [TC7W53FK,LF](#) [CD4053BM96](#) [MC74HC4053ADWR2G](#) [MAX4051AEEE+](#)
[PI3L720ZHEX](#) [ADG1404YRUZ-REEL7](#) [ADG1208YRZ-REEL7](#) [CD4053BPWRG4](#) [ADG658TRUZ-EP](#) [FSA1256L8X_F113](#) [PI5V330QE](#)
[PI5V331QE](#) [5962-8771601EA](#) [ADG5249FBRUZ](#) [ADG1438BRUZ](#) [ADG5207BCPZ-RL7](#) [ADW54003-0](#) [AD7506JNZ](#) [AD7506KNZ](#)
[AD7506SQ](#) [AD8170AR](#) [AD8183ARUZ](#) [AD8184ANZ](#) [AD8185ARUZ](#) [AD8187ARUZ](#) [AD8188ARUZ](#) [AD8189ARUZ](#) [ADG1208YRUZ-](#)
[REEL7](#) [ADG1409YCPZ-REEL7](#) [ADG5209FBRUZ](#) [ADG1408YRUZ-REEL7](#) [ADG659YRUZ-REEL7](#)