

PI6C4911502D

## High-Performance Differential Fanout Buffer

---

### Features

- 2 LVPECL outputs with two individual dividers
- Up to 1.5GHz output frequency
- Low additive phase jitter:
  - Supports LVPECL, LVDS, CML, HCSL inputs
- Separate input output supply voltage for level shifting
- 2.5V/3.3V power supply
- Industrial temperature support
- Totally Lead-Free & Fully RoHS Compliant (Notes 1 & 2)
- Halogen and Antimony Free. "Green" Device (Note 3)
- For automotive applications requiring specific change control (i.e. parts qualified to AEC-Q100/101/200, PPAP capable, and manufactured in IATF 16949 certified facilities), please [contact us](#) or your local Diodes representative.  
<https://www.diodes.com/quality/product-definitions/>
- Packaging (Pb-free & Green):
  - 16-Pin, TQFN Package (ZH)

---

### Description

The PI6C4911502D is a high-performance fanout buffer device which supports up to 1.5GHz frequency. It also integrates two dividers with user-configurable output dividers on a per-output basis, which provides great flexibility to users. This device is ideal for systems that needs scale-down clock signals to multiple destinations.

---

### Applications

- Networking Systems, including Switches and Routers
- High-Frequency Backplane-Based Computing and Telecom Platforms

#### Notes:

1. No purposely added lead. Fully EU Directive 2002/95/EC (RoHS), 2011/65/EU (RoHS 2) & 2015/863/EU (RoHS 3) compliant.
2. See <https://www.diodes.com/quality/lead-free/> for more information about Diodes Incorporated's definitions of Halogen- and Antimony-free, "Green" and Lead-free.
3. Halogen- and Antimony-free "Green" products are defined as those which contain <900ppm bromine, <900ppm chlorine (<1500ppm total Br + Cl) and <1000ppm antimony compounds.

**PI6C4911502D**

**Block Diagram**

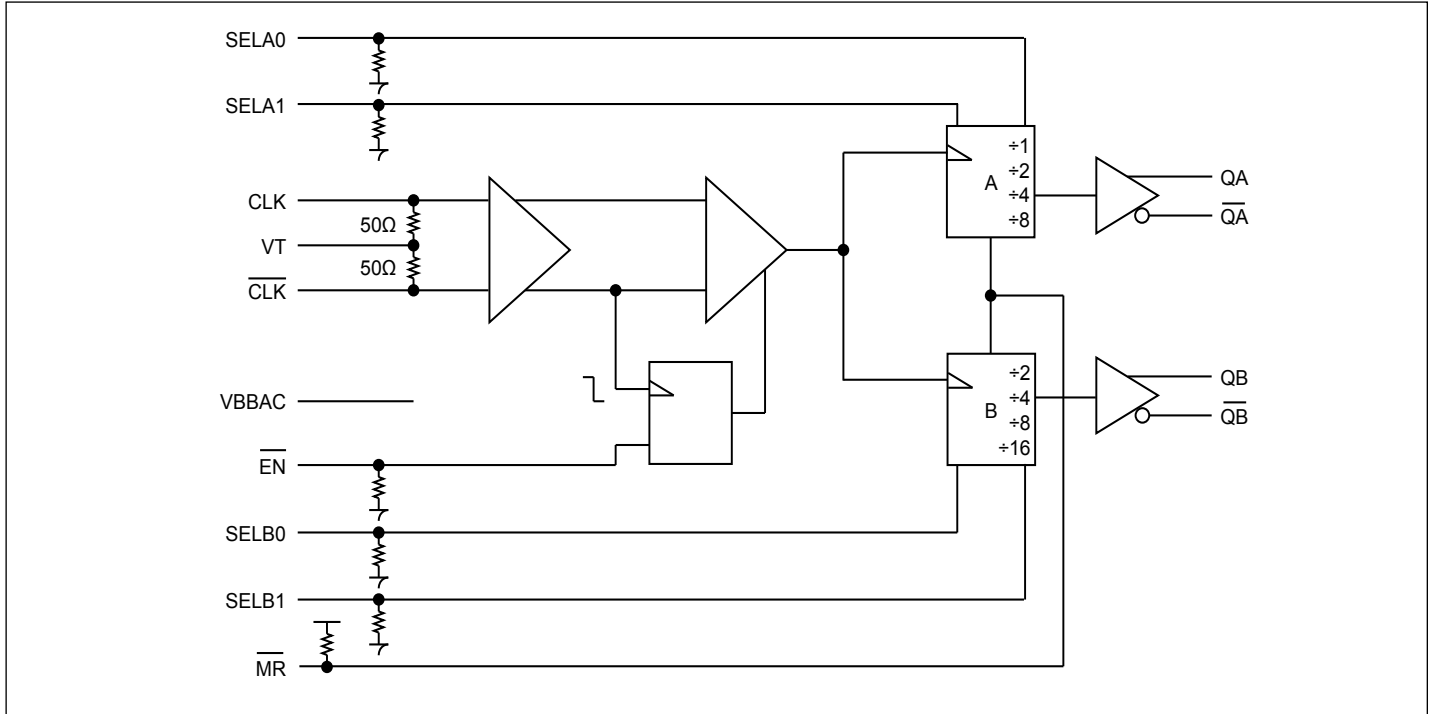

## Pin Configuration

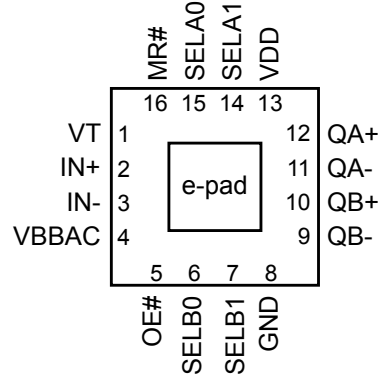

## Pin Description

Pin #	Pin Name	Type	Description
1	VT		Internal 100Ω center-tapped termination pin for input clock
2,	IN+	Input	Differential input
3	IN-		
4	VBBAC		Output reference for capacitor coupled inputs only
5	OE#	Input	Synchronous output enable, active low
6,	SELB0	Input	Bank B divider select pins
7	SELB1		
8	GND	Power	Ground
9,	QB-	Output	Bank B LVPECL output pair
10	QB+		
11,	QA-	Output	Bank A LVPECL output pair
12	QA+		
13	V <sub>DD</sub>	Power	Power supply pin
14,	SELA1	Input	Bank A divider select pins
15	SELA0		
16	MR#	Input	Master reset
	EPAD	Power	Ground, must connect thermal vias (=> 4) to GND plane

## Function Table

Table 1: Output Enable and Master Reset Function

IN	OE#	MR#	Output State
Rising edge	0	1	Output Enabled
Falling edge	1	1	Hold Output
X	X	0	Reset Output

Table 2: Output A Divide Function

SELA1	SELA0	QA Output
0	0	Divide by 1
0	1	Divide by 2
1	0	Divide by 4
1	1	Divide by 8

Table 3: Output B Divide Function

SELB1	SELB0	QB Output
0	0	Divide by 2
0	1	Divide by 4
1	0	Divide by 8
1	1	Divide by 16

## Maximum Ratings

(Above which the useful life may be impaired. For user guidelines, not tested.)

Storage Temperature.....	-55°C to +150°C
Supply Voltage to Ground Potential ( $V_{DD}, V_{DDO}$ )	-0.5V to +4.6V
Inputs (Referenced to GND) .....	-0.5V to $V_{DD}+0.5V$
Clock Output (Referenced to GND).....	-0.5V to $V_{DD}+0.5V$
Latch up .....	200mA
ESD Protection (Input) .....	2000V min (HBM)
Junction Temperature .....	125°C max

**Note:**

Stresses greater than those listed under MAXIMUM RATINGS may cause permanent damage to the device. This is a stress rating only and functional operation of the device at these or any other conditions above those indicated in the operational sections of this specification is not implied. Exposure to absolute maximum rating conditions for extended periods may affect reliability.

## Power Supply Characteristics and Operating Conditions

Symbol	Parameter	Test Condition	Min.	Typ.	Max.	Units
$V_{DD}$	Core Supply Voltage		2.375		3.465	V
$I_{DD}$	Power Supply Current	Outputs unloaded		70		mA
$T_A$	Ambient Operating Temperature <sup>(1)</sup>		-40		85	°C
$I_{BB}$	Sink Source Current			±0.5		mA
$V_{BBAC}$	Output Voltage Reference @ 100µA					
	$V_{DD} = 3.3V$			1960		mV
	$V_{DD} = 2.5V$			1160		

Note 1: Either  $T_A$  or  $T_B$  used as operating condition.

## DC Electrical Specifications - Differential Inputs

Symbol	Parameter	Test Condition	Min.	Typ.	Max.	Units
$I_{IH}$	Input High Current	Input = $V_{DD}$			240	µA
$I_{IL}$	Input Low Current	Input = GND	-150			µA
$C_{IN}$	Input Capacitance			6		pF
$V_{IH}$	Input High Voltage				$V_{DD}+0.3$	V
$V_{IL}$	Input Low Voltage		-0.3			V
$V_{ID}$	Input Differential Amplitude PK-PK	Slew rate > 0.7V/ns for minimum input signal	0.15		1.3	V
$V_{CM}$	Common Model Input Voltage		0.25		$V_{DD}-1.2$	V

**PI6C4911502D**

**DC Electrical Specifications - LVCMOS Inputs**

Symbol	Parameter	Conditions	Min.	Typ.	Max.	Units
I <sub>IH</sub>	Input High Current	Input = V <sub>DD</sub>			150	μA
I <sub>IL</sub>	Input Low Current	Input = GND	-150			μA
V <sub>IH</sub>	Input High Voltage	V <sub>DD</sub> =3.3V	2.0		V <sub>DD</sub> +0.3	V
V <sub>IL</sub>	Input Low Voltage	V <sub>DD</sub> =3.3V	-0.3		0.8	V
V <sub>IH</sub>	Input High Voltage	V <sub>DD</sub> =2.5V	1.7		V <sub>DD</sub> +0.3	V
V <sub>IL</sub>	Input Low Voltage	V <sub>DD</sub> =2.5V	-0.3		0.7	V

**DC Electrical Specifications - LVPECL Outputs**

**2.5V ± 5%**

Parameter	Description	Conditions	Min.	Typ.	Max.	Units
V <sub>OH</sub>	Output High Voltage	LVPECL test diagram	V <sub>DDO</sub> -1.2		V <sub>DDO</sub> -0.7	V
V <sub>OL</sub>	Output Low Voltage	LVPECL test diagram	V <sub>DDO</sub> -1.9		V <sub>DDO</sub> -1.4	V

**3.3V ± 5%**

Parameter	Description	Conditions	Min.	Typ.	Max.	Units
V <sub>OH</sub>	Output High Voltage	LVPECL test diagram	V <sub>DDO</sub> -1.2		V <sub>DDO</sub> -0.7	V
V <sub>OL</sub>	Output Low Voltage	LVPECL test diagram	V <sub>DDO</sub> -2.0		V <sub>DDO</sub> -1.4	V

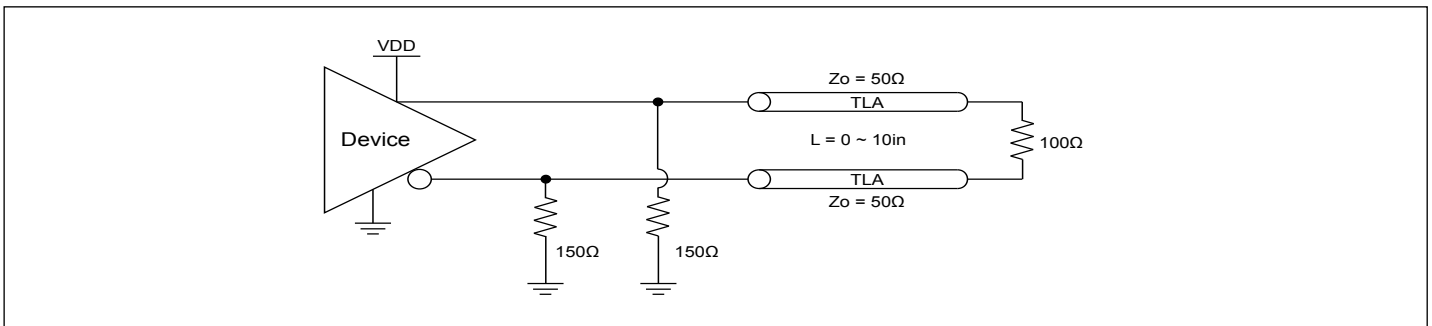
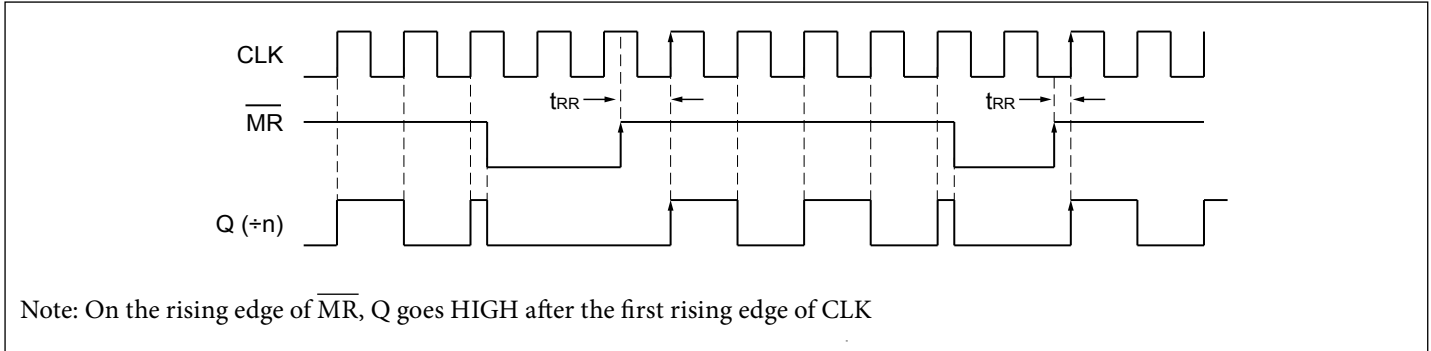

**Figure 1: LVPECL Test Diagram**

**PI6C4911502D**

### AC Electrical Specifications – Differential Outputs

Parameter	Description	Conditions		Min.	Typ.	Max.	Units
$F_{OUT}$	Clock Output Frequency	LVPECL				1500	MHz
$T_r$	Output Rise Time, 3.3V power supply @ 1GHz	From 20% to 80%	LVPECL	100	140	200	ps
	Output Rise Time, 2.5V power supply @ 1GHz			100	140	220	
$T_f$	Output Fall Time, 3.3V power supply @ 1GHz	From 80% to 20%	LVPECL	100	160	200	ps
	Output Fall Time, 2.5V power supply @ 1GHz			100	160	220	
$T_{ODC}$	Output Duty Cycle	Frequency <650MHz, $V_{ID} \geq 400mV$	LVPECL (<250MHz)	48		52	%
		Frequency <1GHz, $V_{ID} \geq 400mV$	LVPECL	45		55	
		Frequency <1.5GHz, $V_{ID} \geq 400mV$	LVPECL	40		60	
$V_{PP}$	Output Swing Single-Ended	LVPECL Outputs @ <1GHz		600		800	mV
		LVPECL Outputs @ >1GHz		400		700	
$T_j$	Buffer output jitter RMS	156.25MHz, 12kHz to 20MHz				1	ps
		156.25MHz, 10kHz to 1MHz				1	ps
$T_{SK}$	Output Skew				10	30	ps
$T_{PD}$	Propagation Delay	@ 3.3V, 100MHz			800		ps
$T_{OD}$	Valid to HiZ					80	ns
$T_{OE}$	Output Enable Time					2 input clock cycle	ns



**Figure 2: Master Reset Timing Diagram**

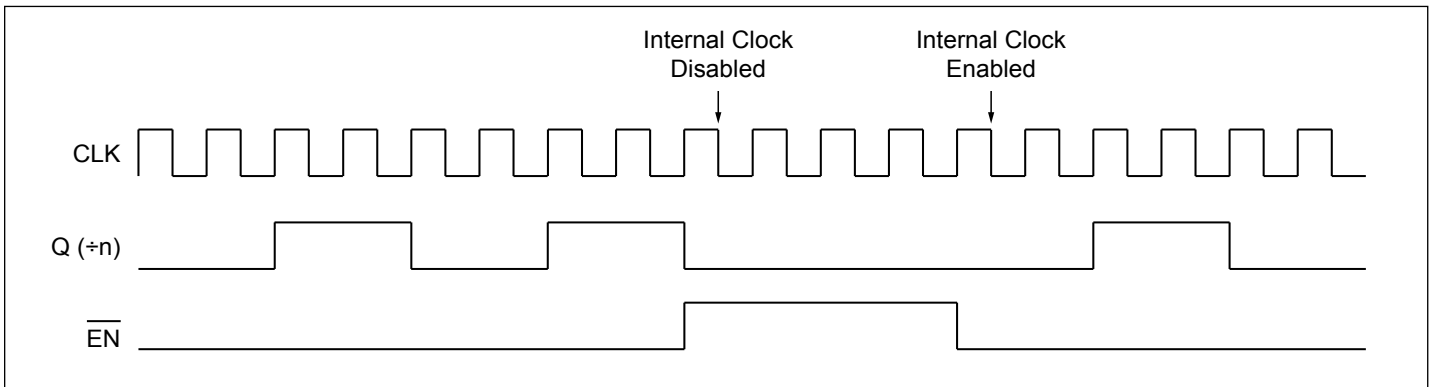

**Figure 3: Output Enable Timing Diagram**

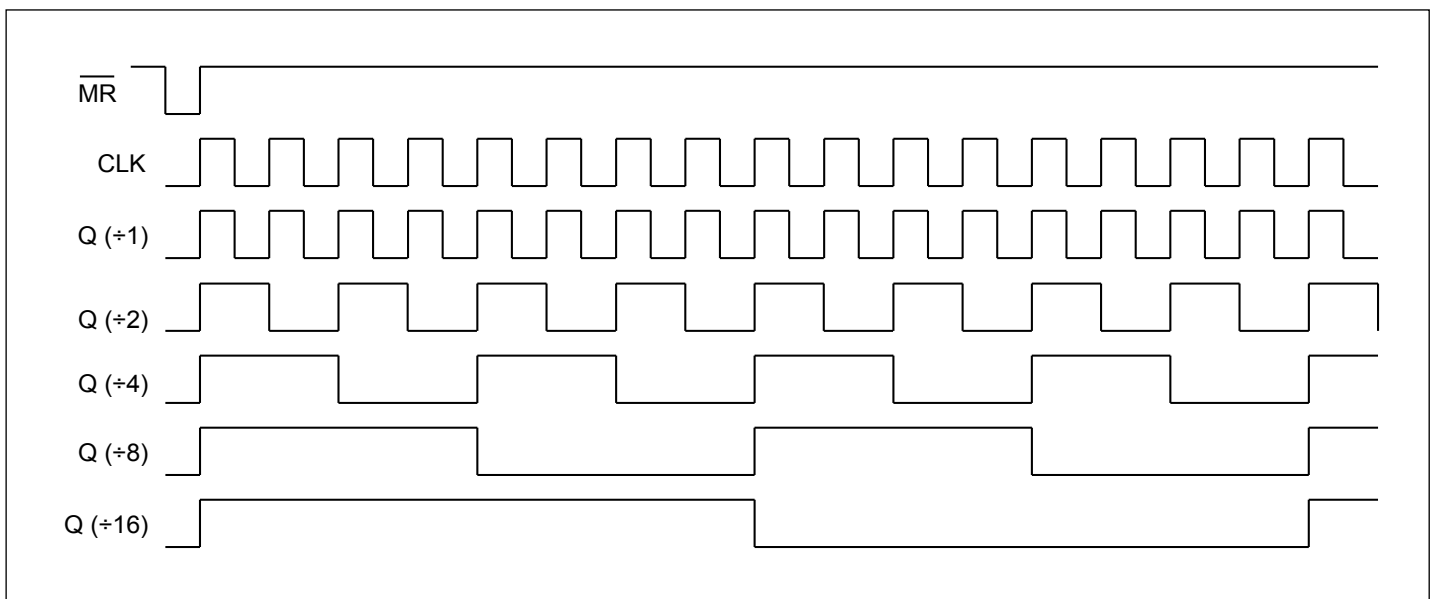

**Figure 4: Timing Diagram**



**LVPECL Output Swing vs Frequency**

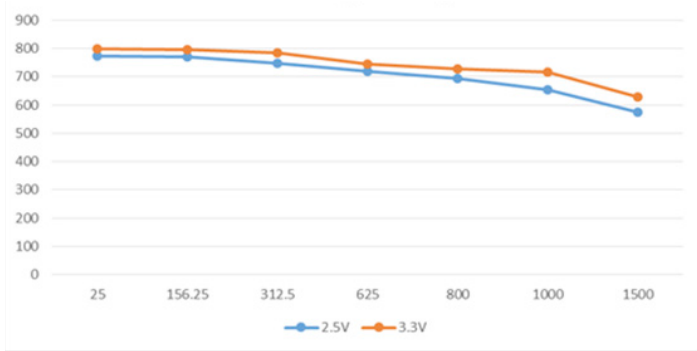

**Propagation Delay vs Temperature**

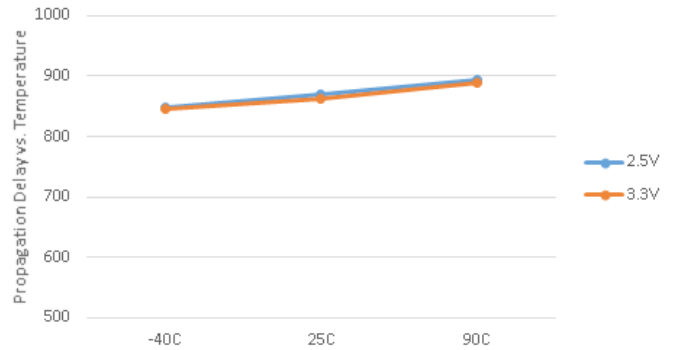

**1.5GHz LVPECL Waveform**

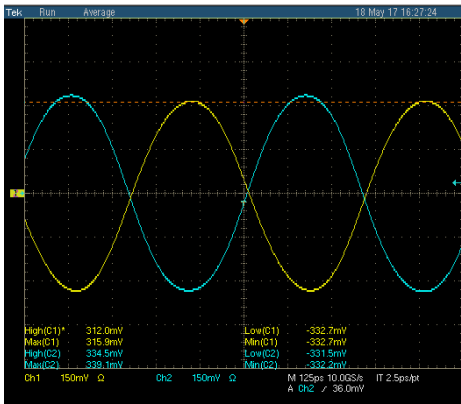

**2.5V LVPECL Waveform**

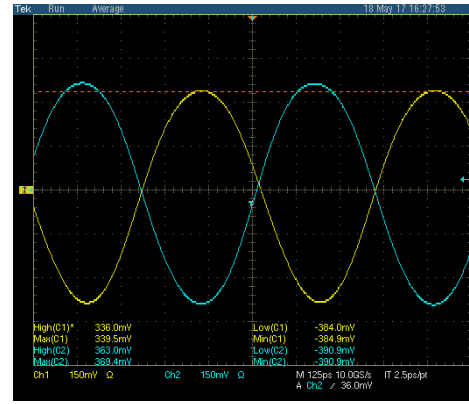

**3.3V LVPECL Waveform**

**Phase Noise and Additive Jitter**

Output Phase Noise (Dark Blue) vs Input Phase Noise (Light Blue)

Additive jitter is calculated at 156.25MHz ~ 27fs RMS (12kHz to 20MHz). Additive jitter =  $\sqrt{(\text{Output jitter}^2 - \text{Input jitter}^2)}$ .

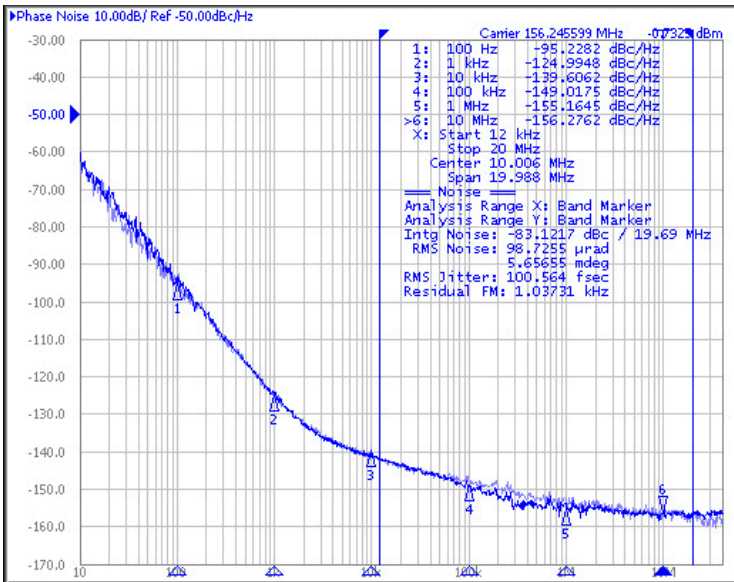

**Configuration Test Load Board Termination for LVPECL Outputs**

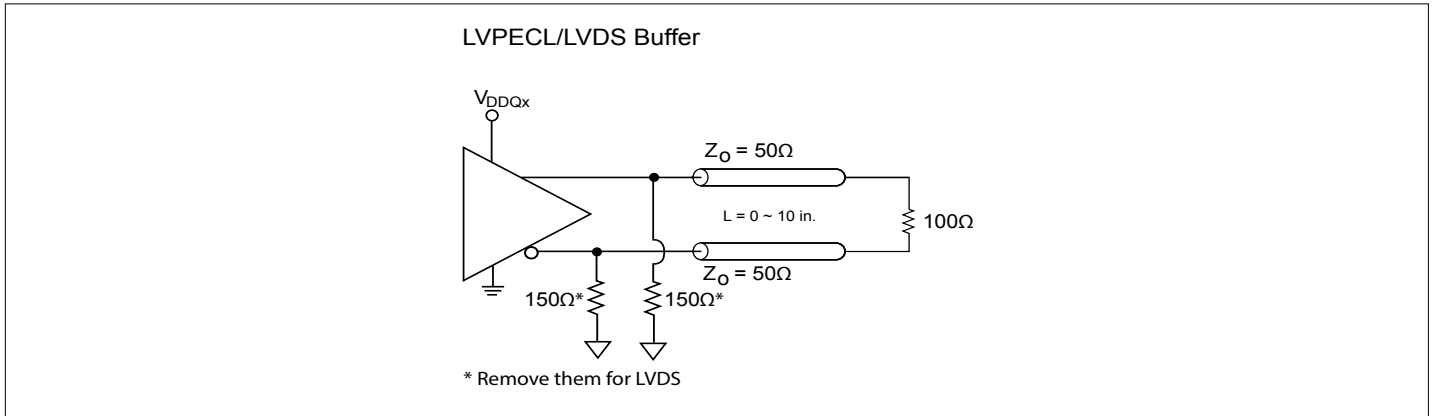

**Part Marking**

Top mark not available at this time. To obtain advance information regarding the top mark, please contact your local sales representative.

**PI6C4911502D**

**Packaging Mechanical**

**16-TQFN (ZH)**

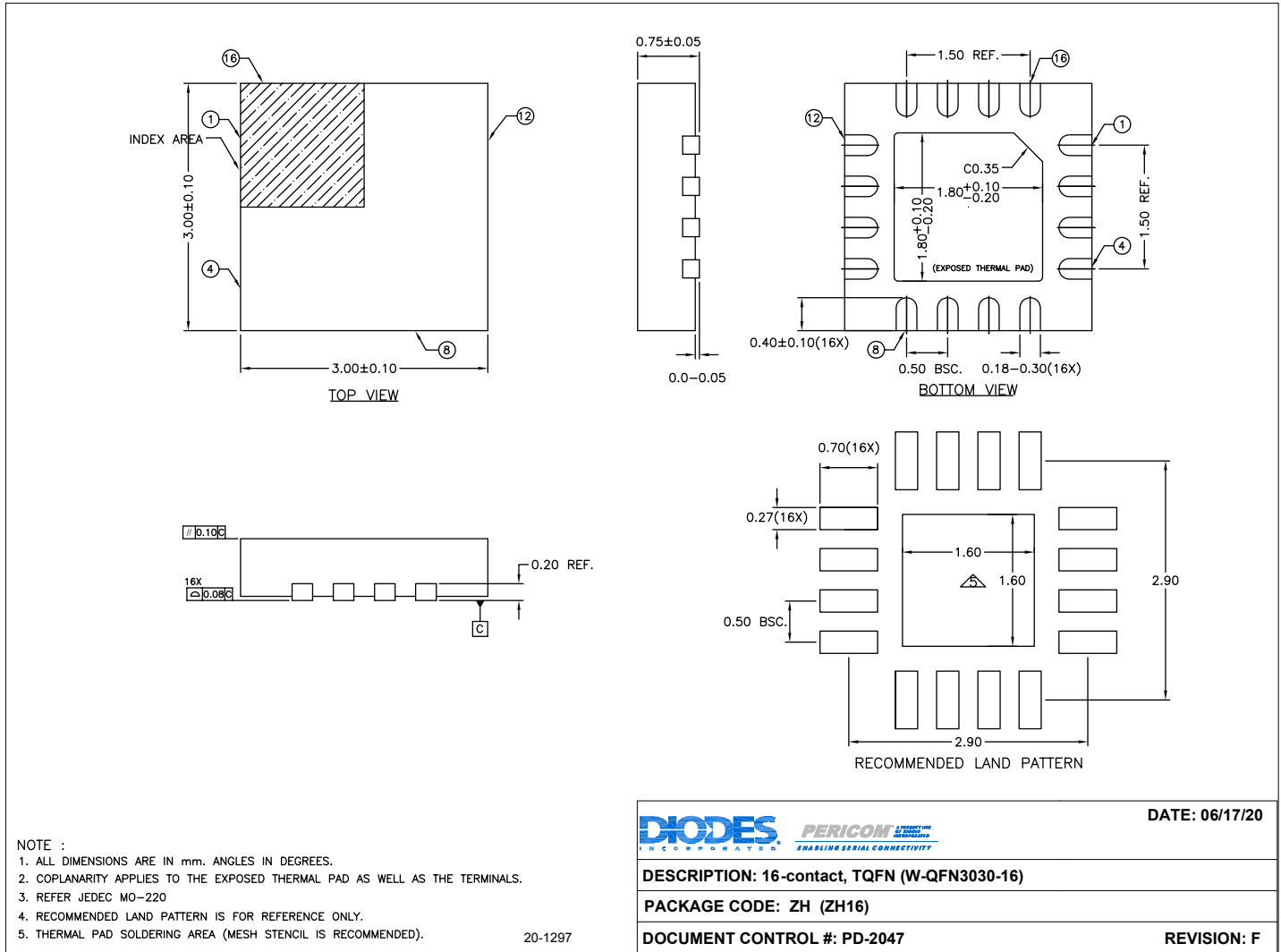

**For latest package information:**

See <http://www.diodes.com/design/support/packaging/pericom-packaging/packaging-mechanicals-and-thermal-characteristics/>.

**Ordering Information**

Ordering Code	Package Code	Package Description	Operating Temperature
PI6C4911502DZHIEX	ZH	16-Contact, W-QFN3030-16 (TQFN)	-40°C to 85°C

**Notes:**

1. No purposely added lead. Fully EU Directive 2002/95/EC (RoHS), 2011/65/EU (RoHS 2) & 2015/863/EU (RoHS 3) compliant.
2. See <https://www.diodes.com/quality/lead-free/> for more information about Diodes Incorporated's definitions of Halogen- and Antimony-free, "Green" and Lead-free.
3. Halogen- and Antimony-free "Green" products are defined as those which contain <900ppm bromine, <900ppm chlorine (<1500ppm total Br + Cl) and <1000ppm antimony compounds.
4. I = Industrial
5. E = Pb-free and Green
6. X suffix = Tape/Reel

**IMPORTANT NOTICE**

1. DIODES INCORPORATED AND ITS SUBSIDIARIES (“DIODES”) MAKE NO WARRANTY OF ANY KIND, EXPRESS OR IMPLIED, WITH REGARDS TO ANY INFORMATION CONTAINED IN THIS DOCUMENT, INCLUDING, BUT NOT LIMITED TO, THE IMPLIED WARRANTIES OF MERCHANTABILITY, FITNESS FOR A PARTICULAR PURPOSE OR NON-INFRINGEMENT OF THIRD PARTY INTELLECTUAL PROPERTY RIGHTS (AND THEIR EQUIVALENTS UNDER THE LAWS OF ANY JURISDICTION).
2. The Information contained herein is for informational purpose only and is provided only to illustrate the operation of Diodes products described herein and application examples. Diodes does not assume any liability arising out of the application or use of this document or any product described herein. This document is intended for skilled and technically trained engineering customers and users who design with Diodes products. Diodes products may be used to facilitate safety-related applications; however, in all instances customers and users are responsible for (a) selecting the appropriate Diodes products for their applications, (b) evaluating the suitability of the Diodes products for their intended applications, (c) ensuring their applications, which incorporate Diodes products, comply the applicable legal and regulatory requirements as well as safety and functional-safety related standards, and (d) ensuring they design with appropriate safeguards (including testing, validation, quality control techniques, redundancy, malfunction prevention, and appropriate treatment for aging degradation) to minimize the risks associated with their applications.
3. Diodes assumes no liability for any application-related information, support, assistance or feedback that may be provided by Diodes from time to time. Any customer or user of this document or products described herein will assume all risks and liabilities associated with such use, and will hold Diodes and all companies whose products are represented herein or on Diodes' websites, harmless against all damages and liabilities.
4. Products described herein may be covered by one or more United States, international or foreign patents and pending patent applications. Product names and markings noted herein may also be covered by one or more United States, international or foreign trademarks and trademark applications. Diodes does not convey any license under any of its intellectual property rights or the rights of any third parties (including third parties whose products and services may be described in this document or on Diodes' website) under this document.
5. Diodes products are provided subject to Diodes' Standard Terms and Conditions of Sale (<https://www.diodes.com/about/company/terms-and-conditions/terms-and-conditions-of-sales/>) or other applicable terms. This document does not alter or expand the applicable warranties provided by Diodes. Diodes does not warrant or accept any liability whatsoever in respect of any products purchased through unauthorized sales channel.
6. Diodes products and technology may not be used for or incorporated into any products or systems whose manufacture, use or sale is prohibited under any applicable laws and regulations. Should customers or users use Diodes products in contravention of any applicable laws or regulations, or for any unintended or unauthorized application, customers and users will (a) be solely responsible for any damages, losses or penalties arising in connection therewith or as a result thereof, and (b) indemnify and hold Diodes and its representatives and agents harmless against any and all claims, damages, expenses, and attorney fees arising out of, directly or indirectly, any claim relating to any noncompliance with the applicable laws and regulations, as well as any unintended or unauthorized application.
7. While efforts have been made to ensure the information contained in this document is accurate, complete and current, it may contain technical inaccuracies, omissions and typographical errors. Diodes does not warrant that information contained in this document is error-free and Diodes is under no obligation to update or otherwise correct this information. Notwithstanding the foregoing, Diodes reserves the right to make modifications, enhancements, improvements, corrections or other changes without further notice to this document and any product described herein. This document is written in English but may be translated into multiple languages for reference. Only the English version of this document is the final and determinative format released by Diodes.
8. Any unauthorized copying, modification, distribution, transmission, display or other use of this document (or any portion hereof) is prohibited. Diodes assumes no responsibility for any losses incurred by the customers or users or any third parties arising from any such unauthorized use.

Copyright © 2021 Diodes Incorporated

[www.diodes.com](http://www.diodes.com)

## X-ON Electronics

Largest Supplier of Electrical and Electronic Components

*Click to view similar products for [Clock Buffer](#) category:*

*Click to view products by [Diodes Incorporated](#) manufacturer:*

Other Similar products are found below :

[NB7VQ58MMNG](#) [IDT49FCT805ASO](#) [P5P2305AF-1H08SR](#) [9DBV0941AKILF](#) [MC10E111FNG](#) [5PB1216NDGK](#) [6V31024NLG](#)  
[P5I2305AF-1H08SR](#) [9DBV0941AKILFT](#) [NB3L02FCT2G](#) [NB3L03FCT2G](#) [NB7VQ58MMNHTBG](#) [PI49FCT32807QE](#) [552-02SPGGI](#)  
[MDB1900ZCQY](#) [5PB1203NTGK8](#) [5PB1213NTGK](#) [5PB1203NTGK](#) [PI49FCT20802QE](#) [PI6C4931502-04LIE](#) [9ZX21901DKLF](#)  
[NB7L1008MNG](#) [NB7L14MN1G](#) [PI49FCT20807QE](#) [PI6C4931502-04LIE](#) [8T73S1802NLGI/W](#) [PI6C4931504-04LIE](#) [5P1103A515NLGI](#)  
[PI6C10806BLEX](#) [PL133-97QI-R](#) [5P1105A504NLGI](#) [8T39S04ANBGI](#) [8T39S06ANBGI](#) [5PB1104CMG18](#) [RC19013AGNG#BB0](#)  
[RC19020A072GN2#BB0](#) [RC19016AGN1#BB0](#) [RC19216AGN6#BD0](#) [RC19016A100GN1#BB0](#) [RC19013A100GNG#BB0](#)  
[PI6C4911502DZHIEX](#) [9FGL0651DKILF](#) [9FGL0641DKILF](#) [RC19204AGNL#BB0](#) [RC19202AGNT#BD0](#) [MC100EP11DR2G](#) [SI53301-B-](#)  
[GMR](#) [SI5330C-B00209-GM](#) [NB3RL02FCT2G](#) [SY75578LMG](#)