

Low Skew, 1-To-2 LVC MOS / LVTTTL Fanout Buffer

Features

- 2 LVC MOS / LVTTTL outputs
- LVC MOS / LVTTTL clock input accepts LVC MOS or LVTTTL input levels
- Maximum output frequency: 250MHz
- Output skew: 25ps (typical)
- Part-to-part skew: 250ps (typical)
- Small 8 lead SOIC package saves board space
- Full 3.3V, 2.5V operation modes
- -40°C to 85°C ambient operating temperature
- Lead-Free package fully RoHS compliant

Description

The PI6C49X0202 is a low skew, 1-to-2 LVC MOS/LVTTTL High Performance Fanout Buffer. The PI6C49X0202 has a single ended clock input. The single ended clock input accepts LVC MOS or LVTTTL input levels. The PI6C49X0202 features a pair of LVC MOS/LVTTTL outputs. Guaranteed output and part-to-part skew characteristics make the PI6C49X0202 ideal for clock distribution applications demanding well defined performance and repeatability.

Block Diagram

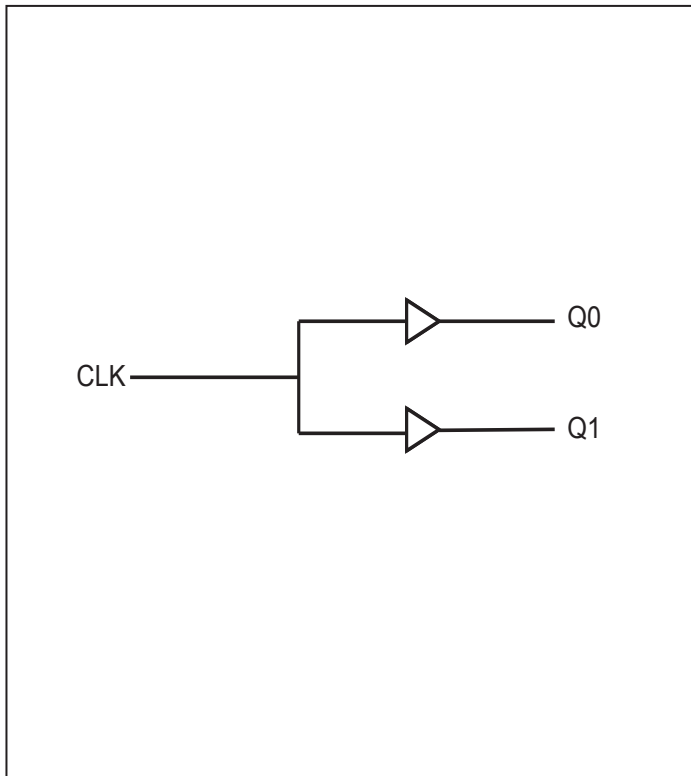

Pin Assignment

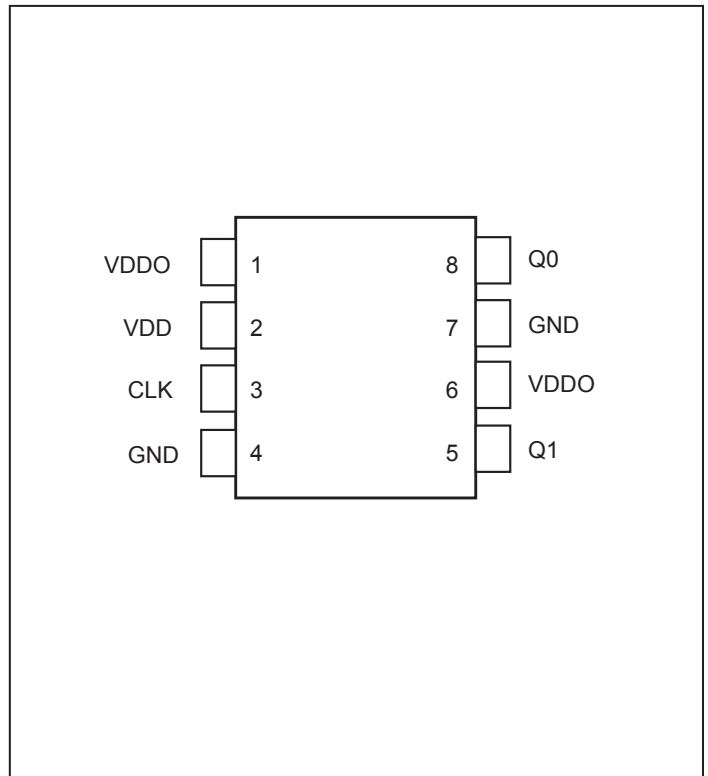

Pin Descriptions

Pin#	Pin Name	Pin Type		Pin Description
1, 6	VDDO	Power		Output supply pins.
2	VDD	Power		Core supply pin.
3	CLK	Input	Pulldown	LVCMOS / LVTTL clock input.
4, 7	GND	Power		Power supply ground.
5	Q1	Output		Single clock output. LVCMOS / LVTTL interface levels.
8	Q0	Output		Single clock output. LVCMOS / LVTTL interface levels.

Note: *Pulldown* refer to internal input resistors, typical values in Pin Characteristics table.

Pin Characteristics

Symbol	Parameter	Test Conditions	Min.	Typical	Max.	Units
C_N	Capacitance			4		pF
$R_{PULLDOWN}$	Input Pulldown Resistor			51		k Ω
R_{OUT}	Output Impedance		5	7	12	Ω

Maximum Ratings

(Above which useful life may be impaired. For user guidelines, not tested.)

Maximum Supply Voltage, VDD, VDDO	4.6V
Inputs, V_I	-0.5V to VDD+0.5V
Output, V_O	-0.5V to VDDO+0.5V
Storage Temperature	-65°C to 150°C
ESD Protection (HBM).....	2000V

Note:

Stresses beyond those listed under Absolute Maximum Ratings may cause permanent damage to the device. These ratings are stress specifications only. Functional operation of product at these conditions or any conditions beyond those listed in the DC Characteristics or AC Characteristics

is not implied. Exposure to absolute maximum rating conditions for extended periods may affect product reliability.

POWER SUPPLY DC CHARACTERISTICS, $T_A = -40^\circ\text{C}$ to 85°C

Symbol	Parameter	Conditions	Min.	Typ.	Max.	Units
VDD	Core Supply Voltage	3.3V Operation	3.135	3.3	3.465	V
		2.5V Operation	2.375	2.5	2.625	
VDDO	Output Power Supply Voltage	3.3V Supply	3.135	3.3	3.465	V
		2.5V Supply	2.375	2.5	2.625	
IDD	Power Supply Current				5	mA
IDDO	Output Supply Current	unloaded, 25MHz			6.5	mA

 Note: Parameters measured up to f_{\max} unless otherwise noted.

LVCMOS / LVTTTL DC CHARACTERISTICS, $T_A = -40^{\circ}\text{C}$ to 85°C

Symbol	Parameter	Conditions	Min.	Typ.	Max.	Units
V_{IH}	Input High Voltage	VDD = 3.3V	2		VDD+0.3	V
		VDD = 2.5V	1.7		VDD+0.3	
V_{IL}	Input Low Voltage	VDD = 3.3V	-0.3		0.8	V
		VDD = 2.5V	-0.3		0.8	
I_{IH}	Input High Current	VDD = $V_{IN} = 3.465\text{V}$			100	μA
		VDD = $V_{IN} = 2.625\text{V}$			80	
I_{IL}	Input Low Current	VDD = 3.465V, $V_{IN} = 0\text{V}$	-5			μA
		VDD = 2.625V, $V_{IN} = 0\text{V}$	-5			
V_{OH}	Output High Voltage	VDDO = 3.3V $I_{OH} = -100\mu\text{A}$	2.9			V
		VDDO = 2.5V $I_{OH} = -100\mu\text{A}$	2.2			V
V_{OL}	Output Low Voltage	VDDO = 3.3V $I_{OL} = 100\mu\text{A}$			0.2	V
		VDDO = 2.5V $I_{OL} = 100\mu\text{A}$			0.2	V

AC CHARACTERISTICS, VDD = 3.3V ± 5%, T_A = -40°C to 85°C

Symbol	Parameter	Conditions	Min.	Typ.	Max.	Units
f _{MAX}	Output Frequency	VDDO = 3.3V	4		250	MHz
		VDDO = 2.5V	4		250	
t _{pLH}	Propagation Delay, Low-to-High; NOTE 1	VDDO = 3.3V, f ≤ 250MHz	1.4		2.2	ns
		VDDO = 2.5V, f ≤ 250MHz	1.5		3.0	
tsk(o)	Output Skew; NOTE 2			25	80	ps
tsk(pp)	Part-to-Part Skew; NOTE 3			250	800	ps
t _R	Output Rise Time NOTE 4	VDDO = 3.3V	100	300	400	ps
		VDDO = 2.5V	100	350	500	
t _F	Output Fall Time NOTE 4	VDDO = 3.3V	100	300	400	ps
		VDDO = 2.5V	100	350	500	
odc	Output Duty Cycle NOTE 5	f ≤ 133MHz	48		52	%
		133MHz < f ≤ 200MHz	47		53	%
		200MHz < f ≤ 250MHz	47		53	%
t _{jit}	Additive RMS Jitter	156.25MHz (@12kHz to 20MHz)		0.1		ps
		125MHz (@12kHz to 20MHz)		0.07		ps

Parameters measured at f_{MAX} unless otherwise noted.

NOTE 1: Measured from VDD / 2 of the input to VDDO / 2 of the output.

NOTE 2: Defined as skew between outputs at the same supply voltage and with equal load conditions. Measured at VDDO / 2.

NOTE 3: Defined as skew between outputs on different devices operating at the same supply voltages and with equal load conditions. Using the same type of inputs on each device, the outputs are measured at VDDO / 2.

NOTE 4: Defined from 20% to 80%

NOTE 5: Measured at VDDO / 2

AC CHARACTERISTICS, $V_{DD} = 2.5V \pm 5\%$, $T_A = -40^\circ C$ to $85^\circ C$

Symbol	Parameter	Conditions	Min.	Typ.	Max.	Units
f_{MAX}	Output Frequency	$V_{DDO} = 2.5V$	4		250	MHz
t_{pLH}	Propagation Delay, Low-to-High; NOTE 1	$V_{DDO} = 2.5V$, $f \leq 250MHz$	1.5		2.8	ns
$tsk(o)$	Output Skew; NOTE 2			25	75	ps
$tsk(pp)$	Part-to-Part Skew; NOTE 3			250	800	ps
t_R	Output Rise Time NOTE 4	$V_{DDO} = 2.5V$	100	350	500	ps
t_F	Output Fall Time NOTE 4	$V_{DDO} = 2.5V$	100	350	500	ps
odc	Output Duty Cycle NOTE 5	$f \leq 133MHz$	48		52	%
		$133MHz < f \leq 200MHz$	47		53	%
		$200MHz < f \leq 250MHz$	42		58	%
t_{jit}	Additive RMS Jitter	156.25MHz (@12kHz to 20MHz)		0.1		ps
		125MHz (@12kHz to 20MHz)		0.07		ps

Parameters measured at f_{MAX} unless otherwise noted.

NOTE 1: Measured from $V_{DD} / 2$ of the input to $V_{DDO} / 2$ of the output.

NOTE 2: Defined as skew between outputs at the same supply voltage and with equal load conditions. Measured at $V_{DDO} / 2$.

NOTE 3: Defined as skew between outputs on different devices operating at the same supply voltages and with equal load conditions. Using the same type of inputs on each device, the outputs are measured at $V_{DDO} / 2$.

NOTE 4: Defined from 20% to 80%

NOTE 5: Measured at $V_{DDO} / 2$

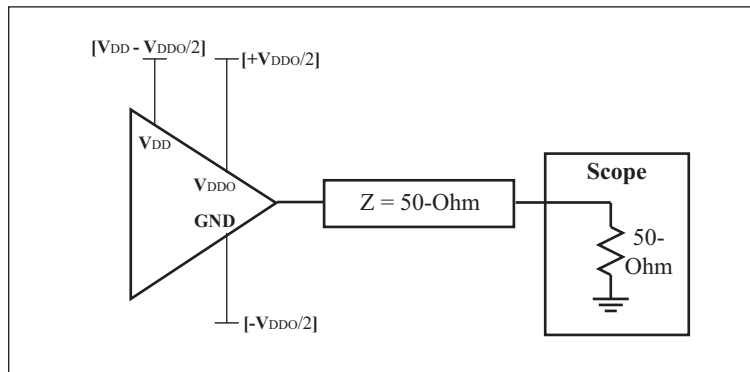
AC Test Circuit Load

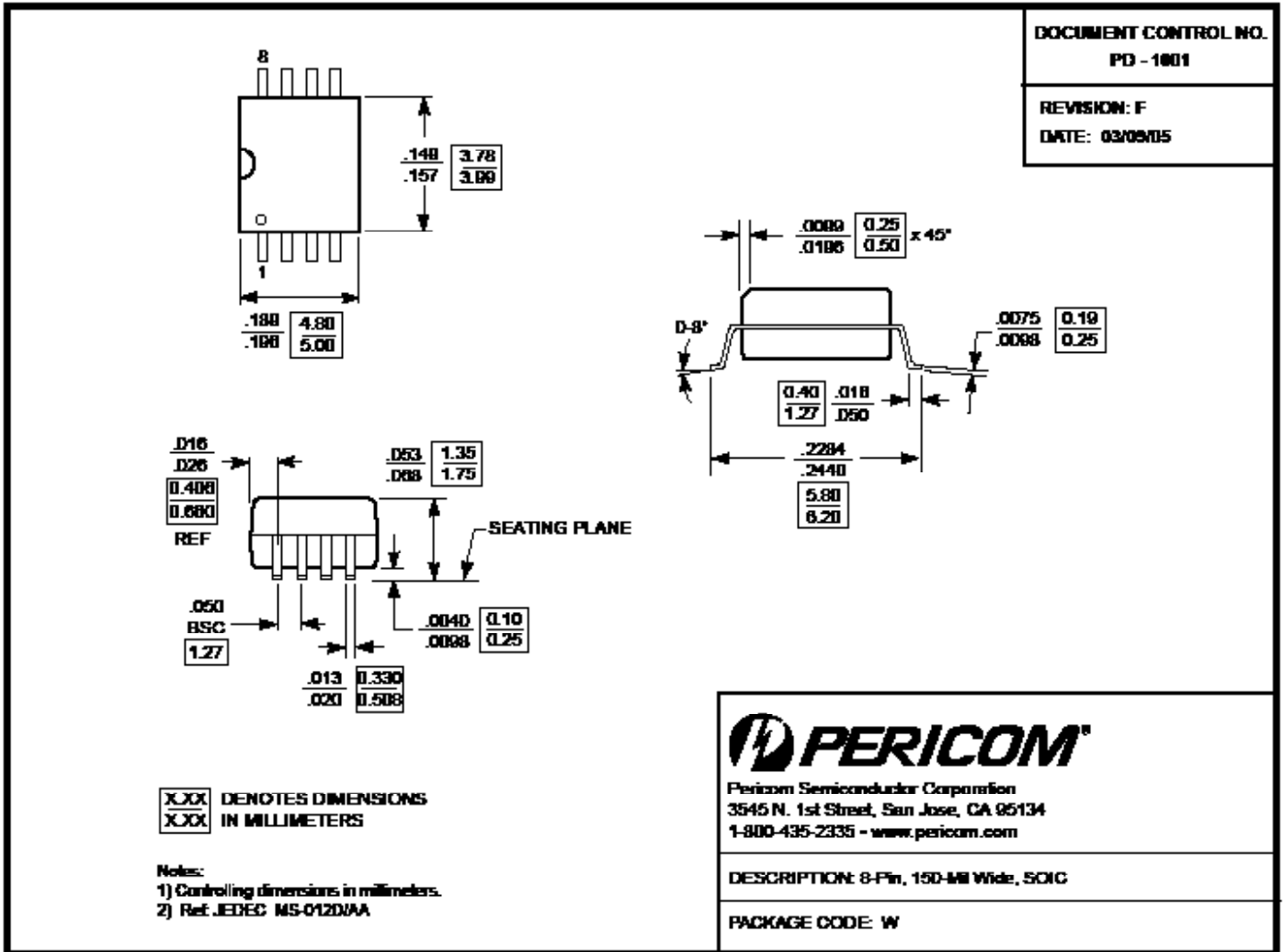

Note:

- For latest package info, please check: <http://www.pericom.com/products/packaging/mechanicals.php>

Ordering Information⁽¹⁻³⁾

Ordering Code	Package Code	Package Description
PI6C49X0202WIE	W	8-pin, Pb-free & Green, SOIC
PI6C49X0202WIEX	W	8-pin, Pb-free & Green, SOIC, Tape & Reel

Notes:

- Thermal characteristics can be found on the company web site at www.pericom.com/packaging/
- E = Pb-free and Green
- Adding an X suffix = Tape/Reel

X-ON Electronics

Largest Supplier of Electrical and Electronic Components

Click to view similar products for [Clock Buffer](#) category:

Click to view products by [Diodes Incorporated](#) manufacturer:

Other Similar products are found below :

[MPC962309EJ-1H](#) [NB4N121KMNG](#) [IDT49FCT805ASO](#) [MK2308S-1HILF](#) [PL133-27GI-R](#) [NB3L02FCT2G](#) [NB3L03FCT2G](#)
[ZL40200LDG1](#) [ZL40205LDG1](#) [9FG1200DF-1LF](#) [9FG1001BGLF](#) [PI49FCT20802QE](#) [PI6C10810HE](#) [NB7L1008MNG](#) [NB7L14MN1G](#)
[PI49FCT20807QE](#) [PI6C4931502-04LIEX](#) [ZL80002QAB1](#) [PI6C4931504-04LIEX](#) [PI6C10806BLEX](#) [ZL40226LDG1](#) [8T73S208B-01NLGI](#)
[SY75578LMG](#) [PI49FCT32805QEX](#) [PL133-27GC-R](#) [MC10LVEP11DG](#) [MC10EP11DTG](#) [MC100LVEP11DG](#) [MC100E111FNG](#)
[MC100EP11DTG](#) [NB7L14MMNG](#) [NB6L14MMNR2G](#) [NB6L611MNG](#) [NB7V58MMNHTBG](#) [NB3N111KMNR4G](#) [ADCLK944BCPZ-R7](#)
[ZL40217LDG1](#) [NB7LQ572MNG](#) [HMC940LC4BTR](#) [9DB801BGLF](#) [ADCLK946BCPZ-REEL7](#) [ADCLK946BCPZ](#) [ADCLK905BCPZ-R2](#)
[ADCLK905BCPZ-R7](#) [ADCLK907BCPZ-R2](#) [ADCLK907BCPZ-WP](#) [ADCLK914BCPZ-R2](#) [ADCLK914BCPZ-R7](#) [ADCLK925BCPZ-R2](#)
[ADCLK925BCPZ-R7](#)