

**Product:** PCI Express® Quad UART I/O Bridge

**Part Numbers:** PI7C9X7954

## Product Description

The PI7C9X7954 is a PCI Express® Quad UART (Universal Asynchronous Receiver-Transmitters) I/O Bridge. It is specifically designed to meet the latest system requirements of high performance, lead (Pb) -free and reduced package sizes. The bridge can be used in a wide range of applications such as Remote Access Servers, Automation, Process Control, Instrumentation, POS, ATM and Multi-port RS232/RS422/RS485 Cards. The PI7C9X7954 provides one x1 PCIe® (dual simplex 2.5 Gbps) uplink port, and it is fully compliant with PCI express 1.1 and PCI® power management 1.2 specifications. The bridge supports four high performance UARTs, each of which supports Baud rate up to 15 Mbps in asynchronous mode. The UARTs support in-band and out-of-band auto flow control, arbitrary trigger I/O mapping and memory mapping. The PI7C9X7954 is fully software compatible with 16C550-type device drivers and can be configured to fit the requirements of RS232, RS422 and RS485 applications. The EEPROM interface is provided for system implementation convenience. Some registers can be pre-programmed via hardware pin settings to facilitate system initialization. For programming flexibility, all of the default configuration registers can be overwritten by EEPROM data, such as sub-vendor and sub-system ID.

## Industry Specifications Compliance

- PCI Express Base Specification, Revision 1.1
- PCI Express CEM Specification, Revision 1.1
- PCI Power Management 1.2
- Advanced Configuration Power Interface (ACPI) Specification
- PCI Standard Hot-Plug Controller (SHPC) and Subsystem Specification Revision 1.0.

## Features

- Support 4 high performance 16C950 UART in single chip
- Fully software compatible with 16C550-type device drivers
- 128-byte transmit and receive FIFO
- Flexible clock pre-scaler from 4 to 46
- Automated in-band flow control using programmable Xon/ Xoff in both directions
- Automated out-of-band flow control using CTS#/ RTS# and/or DSR#/ DTR#
- Arbitrary trigger levels for receiver and transmitter
- FIFO interrupts and automatic in-band and out-of-band flow control
- Data framing sizes: 5, 6, 7, 8 and 9
- Configurable using non-volatile configuration memory (EEPROM)
- Global Interrupt Status and readable FIFO levels to facilitate implementation of efficient device drivers.

- Operation via IO or memory mapping
- Detection of bad data in the receive FIFO
- Baud rate up to 15 Mbps in asynchronous mode.
- Supports up to 256-byte maximum payload size
- 1.8 and 3.3V operation
- Power dissipation: 0.8 W typical in normal mode
- Industrial Temperature Range -40° to 85°
- Package: 14x14mm, 128-pin LQFP, Pb free and 100% Green.

## Software support

- Microsoft™ Windows 2000/2003/XP/Vista 32/64-bit
- Microsoft™ Windows CE 5.0/6.0
- Linux 2.6 and above

## Applications

- Remote Access Servers
- Network / Storage Management
- Factory Automation and Process Control
- Instrumentation
- Multi-port RS-232/ RS-422/ RS-485 Cards
- Point-of-Sale Systems (PoS)
- Industrial Control (IPC)
- Gaming Machines
- Building Automation
- Embedded Systems

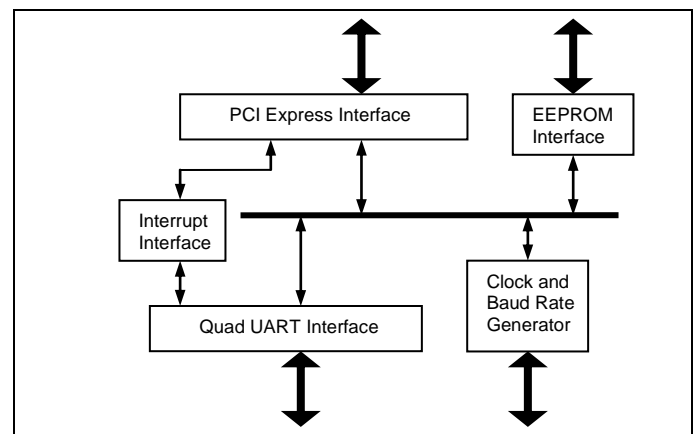

**PI7C9X7954 Block Diagram**

## Order Information

PART NUMBER	PACKAGE	PB-FREE & GREEN	TEMPERATURE
PI7C9X7954BFDE	128 LQFP	YES	-40°C TO 85°C
PI7C9X7954BEVB	Board	Evaluation Board for PI7C9X7954B	

## X-ON Electronics

Largest Supplier of Electrical and Electronic Components

*Click to view similar products for [UART Interface IC](#) category:*

*Click to view products by [Diodes Incorporated](#) manufacturer:*

Other Similar products are found below :

[753167B](#) [ST16C654DCQ64](#) [ST16C654CJ68-F](#) [ST16C654CJ68TR-F](#) [ST68C554IJ68-F](#) [TL28L92IFR](#) [MIC2013-0.5YML TR](#) [MAX3109ETJ+](#)  
[XR82C684CJ/44-F](#) [SCN8031HCCN40](#) [ST16C554DIQ64TR-F](#) [XR88C681CJ-F](#) [XR17D154IV-F](#) [ST16C450CJ44-F](#) [XR68C681CJ-F](#)  
[ST16C554DCQ64-F](#) [IS82C52Z](#) [MAX3100CEE+](#) [MAX3100CPD+](#) [MAX3100EEE+](#) [MAX3100EPD+](#) [MAX3107EAG+](#) [MAX3107EAG+T](#)  
[MAX17851AUP/V+](#) [XR16L2750CM-F](#) [XR16C854IQ-F](#) [XR17V352IB113-F](#) [XR17V354IB176-F](#) [XR20M1172IG28TR-F](#) [XR20M1170IG16-](#)  
[F](#) [ST16C2550IQ48TR-F](#) [SC16C654DBIB64,151](#) [SC16C550BIB48,151](#) [SC16C754BIB80,551](#) [SC16IS750IPW,112](#) [SC16IS752IBS,128](#)  
[SC16IS752IPW,112](#) [SC16IS752IPW,128](#) [SC16IS762IPW,112](#) [PI7C9X7952BFDE](#) [2746391](#) [XR20M1170IL16-F](#) [ST16C550CQ48-F](#)  
[CS82C52Z](#) [XR20M1172IL32TR-F](#) [SCC68070CDA84](#) [XR17D158IV-F](#) [TL16C550CPTRG4](#) [TL16C2552FNG4](#) [NS16C2552TVA/NOPB](#)