

Features

- Wide range of operating supply voltage: 1.50V to 5.5V
- Regulated voltage drive oscillator circuit for reduced power consumption and crystal drive current
- Optimized low crystal drive current oscillation for miniature crystal units
- PT7C5027Axseries: for Flip Chip Bonding
- PT7C5027Bxseries: for Wire Bonding (type)
- PT7C5027Cxseries: for Wire Bonding (type)
- Recommended oscillation frequency range
- Low frequency version: 10MHz to 60MHz
- Multi-stage frequency divider for low-frequency output support: 0.9MHz(min)
- Frequency divider built-in:
- Selectable by version: f₀, f₀/2, f₀/4, f₀/8, f₀/16, f₀/32, f₀/64
- -40 to 85 °C operating temperature range
- Standby function
- High impedance in standby mode, oscillator stops
- CMOS output duty level(1/2VDD)
- 50 ± 5% output duty
- 15pF output drive capability
- Die form or Wafer form

Description

The PT7C5027 series are miniature crystal oscillator module ICs. The oscillator circuit stage has voltage regulator drive, significantly reducing current consumption and crystal current, compared with existing devices, and significantly reducing the oscillator characteristics supply voltage dependency.

Application

- Used for crystal oscillator

Ordering Information

Part no.	Package type
PT7C5027Ax-2DE	Die form
PT7C5027Ax-2WF	Wafer form
PT7C5027Bx-5GDE	Die form
PT7C5027Bx-5GWF	Wafer form
PT7C5027Cx-2DE	Die form
PT7C5027Cx-2WF	Wafer form
PT7C5027Cx-5GDE	Die form
PT7C5027Cx-5GWF	Wafer form

Note: 1. Below is the detailed definition of part no.
 2. “-2” means die thickness is 220±20µm; “-5G” means die thickness is 130±15µm without coating.

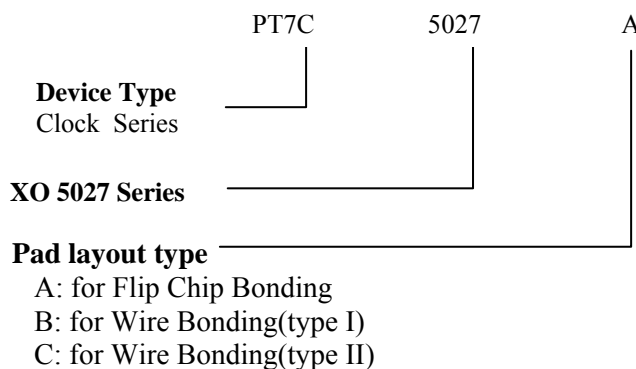

1

Oscillation frequency range, frequency divider function

Suffix	f _{out}	Frequency range
1	f ₀	20 to 60MHz
2	f ₀ /2	
3	f ₀ /4	
4	f ₀ /8	
5	f ₀ /16	
6	f ₀ /32	
7	f ₀ /64	

Series Configuration

Part No.	Output frequency	Operating supply voltage range(V)	Oscillation mode	Recommended oscillation frequency range ¹ (MHz)	Output drive capability(mA)	Standby mode	
						Oscillator stop function	Output state
PT7C5027x1 ^{*2}	f0 ^{*2}	1.50 to 5.0	Fundamental	10 to 60	4	Yes	Hi-Z
PT7C5027x2 ^{*2}	f0/2						
PT7C5027x3 ^{*2}	f0/4						
PT7C5027x4 ^{*2}	f0/8						
PT7C5027x5 ^{*2}	f0/16						
PT7C5027x6 ^{*2}	f0/32						
PT7C5027x7 ^{*2}	f0/64						

Note1: The recommended operating frequency is a yardstick value derived from the crystal used for PTI characteristics authentication. However, the oscillator frequency band is not guaranteed. Specifically, the characteristics can vary greatly due to crystal characteristics and mounting conditions, so the oscillation characteristics of components must be carefully evaluated.

Note2; “x” means A, B or C of different Pad layout type.

Block Diagram

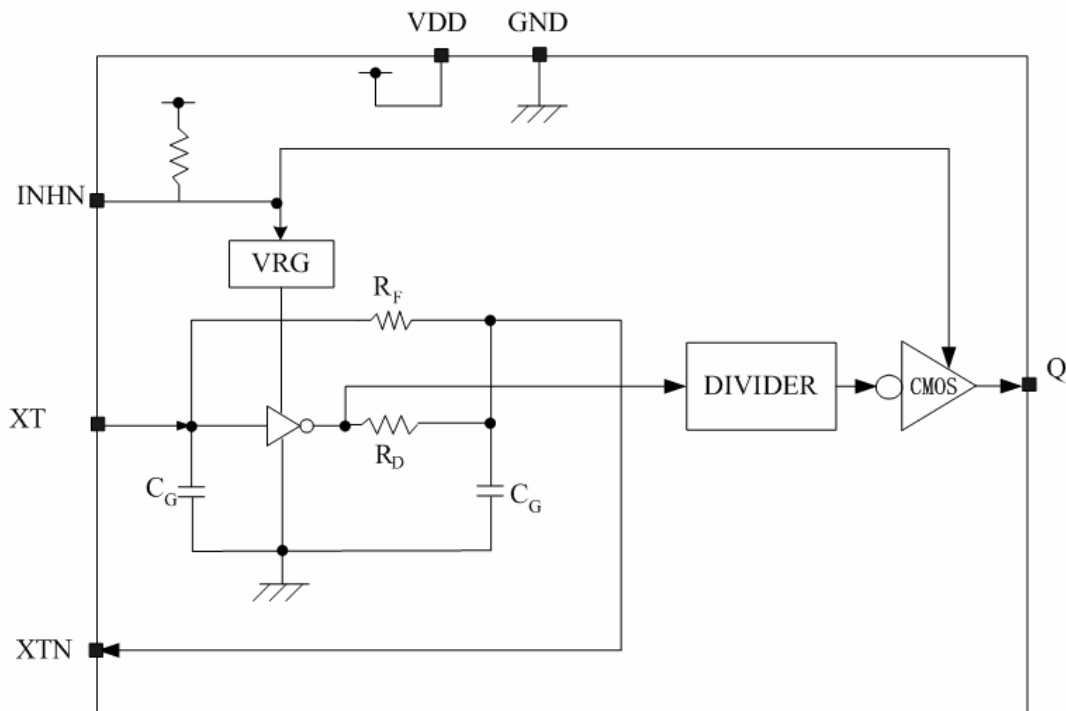

Pad Configuration

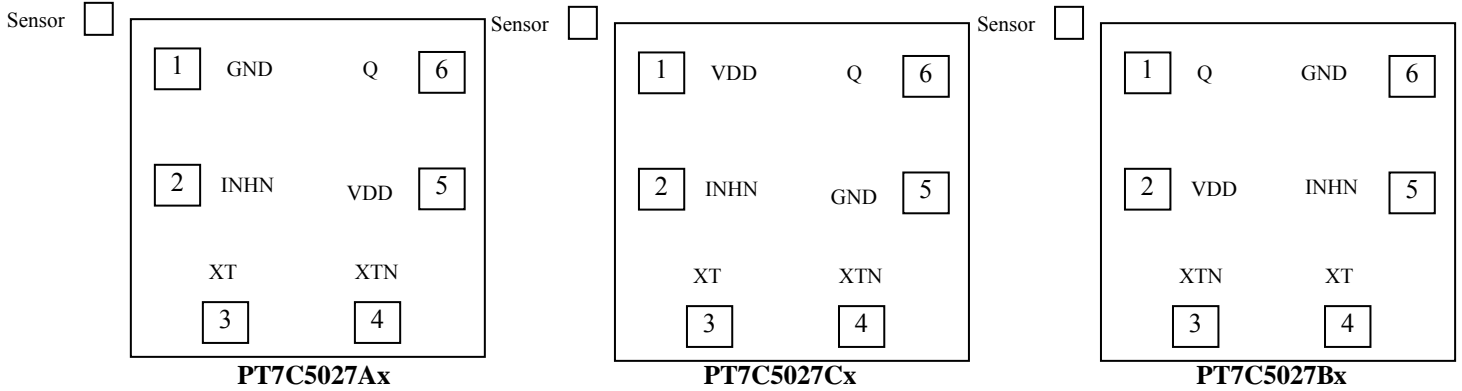

Pad Coordinate File					
Pad Name	X Coordinate	Y Coordinate	Pad Name	X Coordinate	Y Coordinate
sensor	-50	750.00	4	499.00	76.50
1	80.60	620.20	5	589.40	349.20
2	80.60	349.20	6	589.40	620.20
3	176.60	76.50			

Note: Substrate is connected to GND for 130µm die thickness; floating for 220µm die thickness.
Die Size: 770µm*800µm (Including scribe line size 100µm*100µm.)
Die Thickness: PT7C5027Ax-2DE/Ax-2WF/ Cx-2DE/Cx-2WF is 220±20µm; PT7C5027Bx-5GDE/Bx-5GWF/Cx-5GDE/Cx-5GWF is 130µm±15µm without coating.
Pad Size: 90µm*90µm

Pad Description

Sym.	Type	Description	
XTN	O	Amplifier output.	Crystal oscillator connected between XT and XTN
XT	I	Amplifier input.	
INHN	I	Output state control input. High impedance when LOW. Power-saving pull-up resistor built in.	
VDD	P	Supply voltage	
GND	P	Ground	
Q	O	Output. Output frequency determined by internal circuit to one of f ₀ , f ₀ /2, f ₀ /4, f ₀ /8, f ₀ /16, f ₀ /32, f ₀ /64	

Function Description

Standby Function

When INHN goes LOW, the oscillator stops and the output on Q becomes high impedance.

INHN	Q	Oscillator
HIGH (or open)	fo output frequency	Normal operation
Low	High impedance	Stopped

Power-saving Pull-up Resistor

The INHN pin pull-up resistance RUP1 or RUP2 changes in response to the input level (HIGH or LOW). When INHN is tied LOW level, the pull-up resistance is large (RUP1), reducing the current consumed by the resistance. When INHN is left open circuit, the pull-up resistance is small (RUP2), which increases the input susceptibility to external noise. However, the pull-up resistance ties the INHN pin HIGH level to prevent external noise from unexpectedly stopping the output.

Oscillation Detector Function

The PT7C5027 series also feature an oscillation detector circuit. This circuit functions make the outputs disable until the oscillator circuit starts and oscillation becomes stable. This alleviates the danger of abnormal oscillator output at oscillator start-up when power is applied or when INHN is switched.

Maximum Ratings

Note:

Stresses greater than those listed under MAXIMUM RATINGS may cause permanent damage to the device. This is a stress rating only and functional operation of the device at these or any other conditions above those indicated in the operational sections of this specification is not implied. Exposure to absolute maximum rating conditions for extended periods may affect reliability.

Storage Temperature	-65°C to +150°C
Supply Voltage to Ground Potential (V _{DD} to GND)	-0.5V to +4.0V
DC Input (All Other Inputs except V _{DD} & GND) ...	-0.5V to V _{DD} +0.5V
DC Output	-0.5V to V _{DD} +0.5V
DC Output Current (all outputs)	20mA

Recommended Operating Conditions

(GND=0V, unless otherwise noted.)

Sym	Parameter	Conditions	Min	Typ	Max	Unit
V _{DD}	Supply voltage	C _L ≤ 15pF	1.50	-	5.5	V
V _{IN}	Input voltage	-	GND	-	V _{DD}	V
T _A	Operating temperature	-	-40	-	+85	°C
f ₀	Oscillation frequency*1	-	10	-	60	MHz
f _{OUT}	Output frequency	C _L ≤ 15pF	0.9	-	60	MHz

DC Electrical Characteristics

PT7C5027x1 to PT7C5027x7 ($V_{DD} = 1.50$ to $5.5V$, $T_A = -40$ to $85^\circ C$, unless otherwise noted.)

Sym	Parameter	Condition	Rating			Unit	
			Min	Typ	Max		
V_{OH}	HIGH-level output voltage	Q: Measurement cct3, $I_{OH}=4mA$	$V_{DD}-0.4$	-	-	V	
V_{OL}	LOW-level output voltage	Q: Measurement cct3, $I_{OL}=4mA$	-	-	0.4	V	
V_{IH}	HIGH-level input voltage	INH, Measurement cct4	$0.7V_{DD}$	-	-	V	
V_{IL}	LOW-level input voltage	INH, Measurement cct4	-	-	$0.3V_{DD}$	V	
I_Z	Output leakage current	Q: Measurement cct5, $I_{NH}=LOW$	$V_{OH}=V_{DD}$	-	-	10	μA
			$V_{OL}=GND$	-	-	10	μA
I_{DD}	Current consumption	Measurement cct 1, 5027C1(f_0),no load INH=open, $f_0=48MHz$ $f_{OUT}=48MHz$	$V_{DD}=5.0V$	-	2.3	3.2	mA
			$V_{DD}=3.3V$	-	1.6	2.4	mA
			$V_{DD}=2.5V$	-	1.3	2.0	mA
			$V_{DD}=1.8V$	-	1.0	1.5	mA
		Measurement cct 1, 5027C1($f_0/2$),no load INH=open, $f_0=48MHz$ $f_{OUT}=24MHz$	$V_{DD}=5.0V$	-	2.2	3.1	mA
			$V_{DD}=3.3V$	-	1.5	2.3	mA
			$V_{DD}=2.5V$	-	1.2	1.8	mA
			$V_{DD}=1.8V$	-	0.9	1.4	mA
		Measurement cct 1, 5027C1($f_0/4$),no load INH=open, $f_0=48MHz$ $f_{OUT}=12MHz$	$V_{DD}=5.0V$	-	2.0	2.8	mA
			$V_{DD}=3.3V$	-	1.3	2.0	mA
			$V_{DD}=2.5V$	-	1.0	1.5	mA
			$V_{DD}=1.8V$	-	0.8	1.2	mA
		Measurement cct 1, 5027C1($f_0/8$),no load INH=open, $f_0=48MHz$ $f_{OUT}=6MHz$	$V_{DD}=5.0V$	-	1.8	2.5	mA
			$V_{DD}=3.3V$	-	1.1	1.7	mA
			$V_{DD}=2.5V$	-	0.9	1.4	mA
			$V_{DD}=1.8V$	-	0.75	1.15	mA
		Measurement cct 1, 5027C1($f_0/16$),no load INH=open, $f_0=48MHz$ $f_{OUT}=3MHz$	$V_{DD}=5.0V$	-	1.75	2.4	mA
			$V_{DD}=3.3V$	-	1.05	1.6	mA
			$V_{DD}=2.5V$	-	0.85	1.3	mA
			$V_{DD}=1.8V$	-	0.7	1.1	mA
		Measurement cct 1, 5027C1($f_0/32$),no load INH=open, $f_0=48MHz$ $f_{OUT}=1.5MHz$	$V_{DD}=5.0V$	-	1.7	2.3	mA
			$V_{DD}=3.3V$	-	1.0	1.5	mA
			$V_{DD}=2.5V$	-	0.85	1.3	mA
			$V_{DD}=1.8V$	-	0.7	1.1	mA
Measurement cct 1, 5027C1($f_0/64$),no load INH=open, $f_0=48MHz$ $f_{OUT}=0.94MHz$	$V_{DD}=5.0V$	-	1.7	2.3	mA		
	$V_{DD}=3.3V$	-	1.0	1.5	mA		
	$V_{DD}=2.5V$	-	0.85	1.3	mA		
	$V_{DD}=1.8V$	-	0.7	1.1	mA		
I_{ST}	Standby current	Measurement cct1, INH=LOW	-	-	10	μA	
R_{UP1}	INH pull-up resistance	Measurement cct6	0.4	1.5	8	$M\Omega$	
R_{UP2}			30	70	150	$K\Omega$	
R_f	Oscillator feedback resistance	-	50	100	200	$K\Omega$	
C_G	Oscillator capacitance	Design value(a monitor pattern on a wafer is tested),Excluding parasitic capacitance	4.8	6	7.2	pF	
C_D			8	10	12	pF	

AC Electrical Characteristics

Output switching waveform

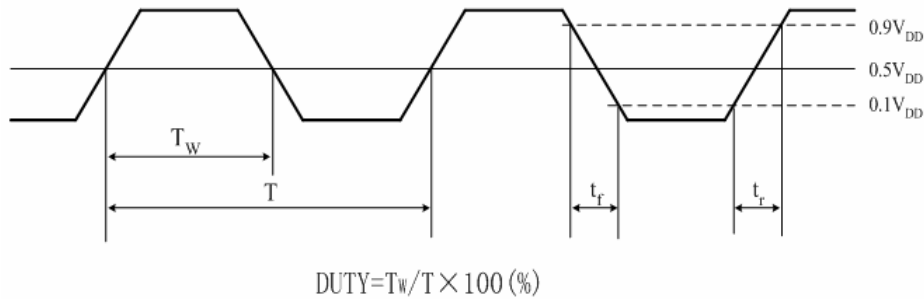

Output disable and oscillation start timing chart

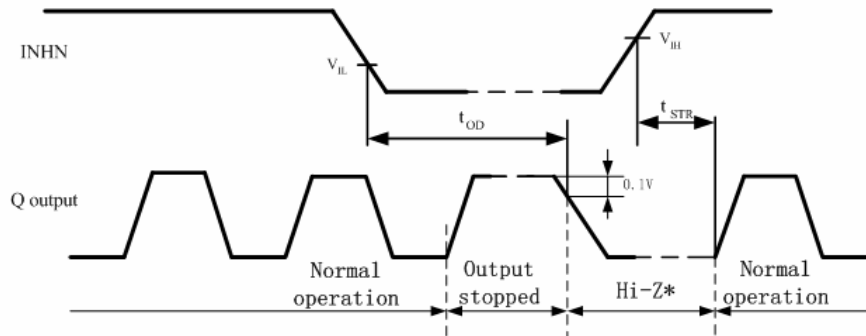

When INHN goes HIGH to LOW, the Q output goes HIGH once and then becomes high impedance.
 When INHN goes LOW to HIGH, the Q output from high impedance to normal output operation when the oscillation starts (oscillation is detected)

*: the high impedance interval in the figure is shown as a LOW level due to the 1KΩ pull-down resistor connected to the Q pin(see “ Measurement circuit 2 ” in the “Measurement circuits” section)

$V_{DD}=1.60$ to 3.63 , $T_a=-40$ to 85 unless otherwise noted

Parameter	Sym	Conditions	Min	Type	Max	Unit	
Output rise time	t_{r2}	Measurement cct1, $C_L=15\text{Pf}$, $0.1V_{DD}$ to $0.9V_{DD}$	$V_{DD}=4.5$ to 5.0 V	-	1.5	3.5	ns
	t_{r2}		$V_{DD}=2.25$ to 3.36 V	-	2.0	4.5	ns
	t_{r2}		$V_{DD}=1.50$ to 2.25 V	-	3.0	5.0	ns
Output fall time	t_{f1}	Measurement cct1, $C_L=15\text{Pf}$, $0.1V_{DD}$ to $0.9V_{DD}$	$V_{DD}=4.5$ to 5.0 V	-	1.5	3.5	ns
	t_{f2}		$V_{DD}=2.25$ to 3.36 V	-	2.0	4.5	ns
	t_{f2}		$V_{DD}=1.50$ to 2.25 V	-	3.0	5.0	ns
Output duty cycle	Duty	Measurement cct 1, $T_A=25$, $C_L=15\text{pF}$	45	50	55	%	
Output disable delay time	t_{OD}	Measurement cct 1, $T_A=25$, $C_L=15\text{pF}$	-	-	50	μS	

Measurement Circuit

Measurement cct1

Measurement parameter: I_{ZZ} , I_{IZ} , Duty, t_{on} , t_r

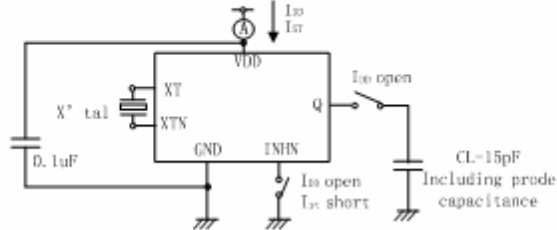

Note: The AC characteristics are observed using an oscilloscope on pin Q

Measurement cct2

Measurement parameter: I_{DD}

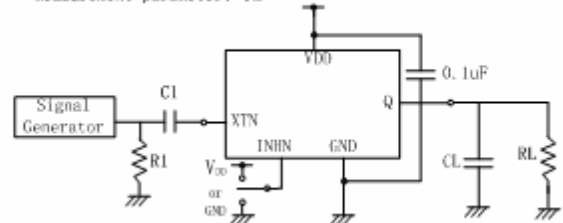

XTN input signal: 1Vp-p, sine wave
 C1: 0.001uF CL: 15pF
 R1: 50 Ohm RL: 1K Ohm

Measurement cct3

Measurement parameter: V_{OH} , V_{OL}

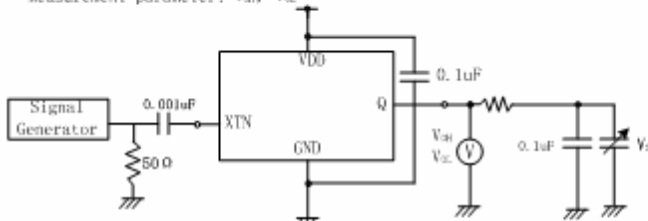

V_S adjusted such that $\Delta V = 50 \times I_{OZ}$

V_S adjusted such that $\Delta V = 50 \times I_{OZ}$

XTN input signal: 1Vp-p, sine wave

Measurement cct4

Measurement parameter: V_{IH} , V_{IL}

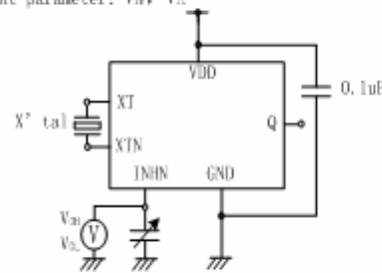

V_{OH} : Voltage is 0V to V_{DD} transition that changes the output state.
 V_{OL} : Voltage is V_{DD} to 0V transition that changes the output state.
 INHN has an oscillation stop function

Measurement cct5

Measurement parameter: I_Z

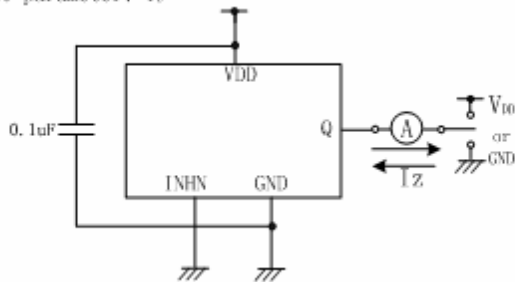

Measurement cct6

Measurement parameter: R_{F1} , R_{F2}

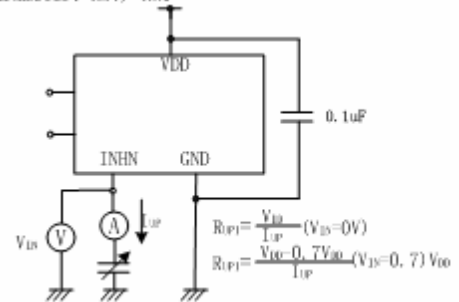

$$R_{F1} = \frac{V_{IH}}{I_{IP}} (V_{DD} = 0V)$$

$$R_{F1} = \frac{V_{IH} - 0.7V_{DD}}{I_{IP}} (V_{DD} = 0.7 V_{DD})$$

Notes

Pericom Technology Inc.

Email: support@pti.com.cn Web Site: www.pti.com.cn, www.pti-ic.com

China: No. 20 Building, 3/F, 481 Guiping Road, Shanghai, 200233, China
Tel: (86)-21-6485 0576 Fax: (86)-21-6485 2181

Asia Pacific: Unit 1517, 15/F, Chevalier Commercial Centre, 8 Wang Hoi Rd, Kowloon Bay, Hongkong
Tel: (852)-2243 3660 Fax: (852)- 2243 3667

U.S.A.: 3545 North First Street, San Jose, California 95134, USA
Tel: (1)-408-435 0800 Fax: (1)-408-435 1100

Pericom Technology Incorporation reserves the right to make changes to its products or specifications at any time, without notice, in order to improve design or performance and to supply the best possible product. Pericom Technology does not assume any responsibility for use of any circuitry described other than the circuitry embodied in Pericom Technology product. The company makes no representations that circuitry described herein is free from patent infringement or other rights, of Pericom Technology Incorporation.

X-ON Electronics

Largest Supplier of Electrical and Electronic Components

Click to view similar products for [Clock Buffer](#) category:

Click to view products by [Diodes Incorporated](#) manufacturer:

Other Similar products are found below :

[MPC962309EJ-1H](#) [NB4N121KMNG](#) [IDT49FCT805ASO](#) [MK2308S-1HILF](#) [PL133-27GI-R](#) [NB3L02FCT2G](#) [NB3L03FCT2G](#)
[ZL40200LDG1](#) [ZL40205LDG1](#) [9FG1200DF-1LF](#) [9FG1001BGLF](#) [PI49FCT20802QE](#) [PI6C10810HE](#) [NB7L1008MNG](#) [NB7L14MN1G](#)
[PI49FCT20807QE](#) [PI6C4931502-04LIEX](#) [ZL80002QAB1](#) [PI6C4931504-04LIEX](#) [PI6C10806BLEX](#) [ZL40226LDG1](#) [8T73S208B-01NLGI](#)
[SY75578LMG](#) [PI49FCT32805QEX](#) [PL133-27GC-R](#) [MC10LVEP11DG](#) [MC10EP11DTG](#) [MC100LVEP11DG](#) [MC100E111FNG](#)
[MC100EP11DTG](#) [NB7L14MMNG](#) [NB6L14MMNR2G](#) [NB6L611MNG](#) [NB7V58MMNHTBG](#) [NB3N111KMNR4G](#) [ADCLK944BCPZ-R7](#)
[ZL40217LDG1](#) [NB7LQ572MNG](#) [HMC940LC4BTR](#) [9DB801BGLF](#) [ADCLK946BCPZ-REEL7](#) [ADCLK946BCPZ](#) [ADCLK905BCPZ-R2](#)
[ADCLK905BCPZ-R7](#) [ADCLK907BCPZ-R2](#) [ADCLK907BCPZ-WP](#) [ADCLK914BCPZ-R2](#) [ADCLK914BCPZ-R7](#) [ADCLK925BCPZ-R2](#)
[ADCLK925BCPZ-R7](#)