

Features

- Power-On Reset Generator with Adjustable Delay Time: 1.25ms to 10s.
- Very Low Quiescent Current: 2.8 μ A Typical
- High Threshold Accuracy: 0.5% Typ.
- Fixed Threshold Voltages for Standard Voltage Rails from 0.9V to 5V and Adjustable Voltage Down to 0.4V are available.
- Manual Reset (\overline{MR}) Input.
- Open-Drain \overline{RESET} Output.
- Temperature Range: -40°C to +125°C
- Package: TDFN2.0x2.0-6L and SOT23-6L

Applications

- DSP or Microcontroller Applications capacitor.
- Notebook/Desktop Computers
- PDAs/Hand-Held Products battery-powered applications.
- Portable/Battery-Powered Products
- FPGA/ASIC Applications

Description

The PT7M3808G family of microprocessor supervisory circuits monitor system voltage from 0.4V to 5.0V, asserting an open-drain \overline{RESET} signal when the SENSE voltage drops below a preset threshold or when the manual reset (\overline{MR}) pin drops to a logic low. The \overline{RESET} output remains low for the user-adjustable delay time after the SENSE voltage and manual reset (\overline{MR}) return above the respective thresholds.

The PT7M3808G series use a precision reference to achieve 0.5% threshold accuracy for $V_{IT} \leq 3.3$ V. The reset delay time can be set to 20ms by disconnecting the C_T pin, 300ms by connecting the C_T pin to V_{DD} using a resistor, or can be user-adjusted between 1.25ms and 10s by connecting the C_T pin to an external capacitor. The PT7M3808 has a very low typical quiescent current of 2.8 μ A so it is well-suited to battery-powered applications. It is available in a small SOT23 and an ultra-small 2.0x2.0 TDFN package, and is fully specified over a temperature range of -40°C to +125°C.

Block Diagram

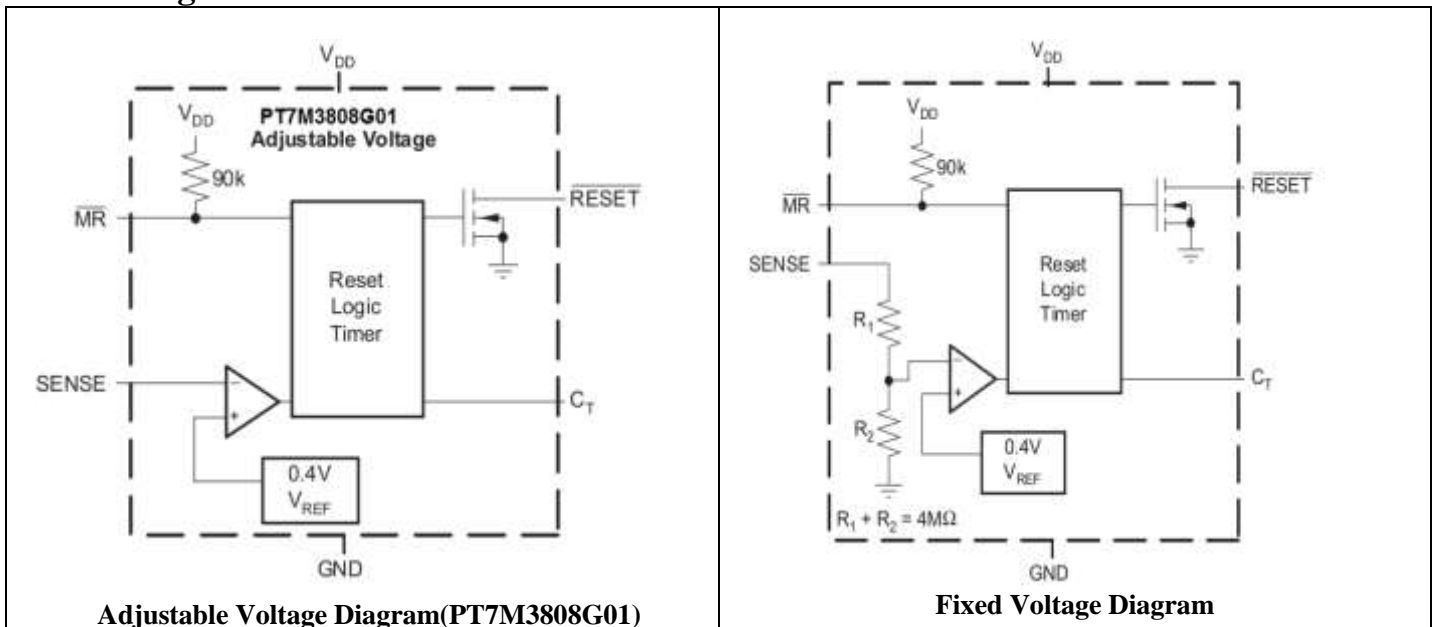

Pin Configuration

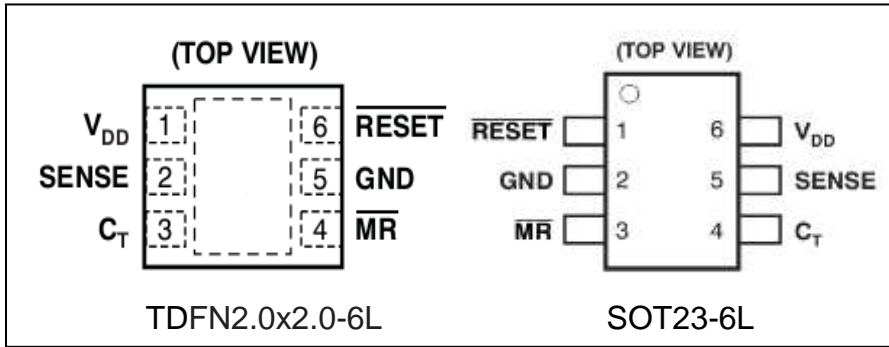

Pin Description

Pin No		Pin Name	Description
SOT23	TDFN		
1	6	$\overline{\text{RESET}}$	An open-drain output that is driven to a low impedance state when $\overline{\text{RESET}}$ is asserted. $\overline{\text{RESET}}$ will remain low (asserted) for the reset period after both SENSE is above V_{IT} and $\overline{\text{MR}}$ is set to a logic high. A pull-up resistor from 10k Ω to 1Mohm should be used on this pin, and allows the reset pin to attain voltages higher than V_{DD} .
2	5	GND	Ground.
3	4	$\overline{\text{MR}}$	Driving the manual reset pin ($\overline{\text{MR}}$) low asserts $\overline{\text{RESET}}$. MR is internally tied to V_{DD} by a 90kohm pull-up resistor.
4	3	C_T	Reset period programming pin. Connection this pin to VDD through a 40k Ω to 200k Ω resistor for 300ms or leaving it open results in fixed delay times 20ms. And connecting this pin with a cap \geq 100pF to ground a user-programmable delay time.
5	2	SENSE	This pin is connected to the voltage to be monitored. If the voltage at this terminal drops below the threshold voltage V_{IT} , then $\overline{\text{RESET}}$ is asserted.
6	1	V_{DD}	Supply Voltage. Place a 0.1uF ceramic capacitor close to this pin.

Maximum Ratings

Storage Temperature	-65 $^{\circ}\text{C}$ to +150 $^{\circ}\text{C}$
Operating Junction Temperature, T_J	-40 $^{\circ}\text{C}$ to +125 $^{\circ}\text{C}$
Input Voltage Range, V_{DD}	-0.3V to +7.0V
C_T Voltage Range, V_{CT}	-0.3V to $V_{DD}+0.5\text{V}$
Other Voltage Range, $V_{\overline{\text{RESET}}}$, $V_{\overline{\text{MR}}}$, V_{SENSE}	-0.3V to +7.0V
RESET pin Current	5mA
ESD rating, HBM	2kV
ESD rating, CDM	500V

Note:

Stresses greater than those listed under MAXIMUM RATINGS may cause permanent damage to the device. This is a stress rating only and functional operation of the device at these or any other conditions above those indicated in the operational sections of this specification is not implied. Exposure to absolute maximum rating conditions for extended periods may affect reliability.

Recommended Operation Conditions

Sym.	Description	Test Conditions	Min.	Typ.	Max.	Unit
V_{DD}	Supply Voltage	-	1.7	--	6.5	V
V_{IH}	Input High Voltage $\overline{\text{MR}}$	-	--	-	V_{DD}	V
	Input High Voltage for Open-drain $\overline{\text{RESET}}$, SENSE	-	0	--	6.5	V
V_{IL}	Input Low Voltage $\overline{\text{MR}}$.	-	-	-	0.3 V_{DD}	V
T_A	Operating Temperature	-	-40	-	125	$^{\circ}\text{C}$

Electrical Characteristics

Unless otherwise specified, $-40^{\circ}\text{C} \leq T_A \leq 125^{\circ}\text{C}$, $1.7\text{V} \leq V_{DD} \leq 6.5\text{V}$, $R_{\text{RESET}}=100\text{k}\Omega$, $C_{\text{RESET}}=50\text{Pf}$, Typical values are at $T_A=+25^{\circ}\text{C}$.

Symbol	Parameter	Test Conditions	Min.	Typ.	Max.	Unit
V_{DD}	Supply voltage		1.7	-	6.5	V
I_{DD}	Supply current	$V_{DD}=3.3\text{V}$, $\overline{\text{RESET}}$ not asserted, $\overline{\text{MR}}$, $\overline{\text{RESET}}$, C_T open.	-	2.8	5.0	μA
		$V_{DD}=6.5\text{V}$, $\overline{\text{RESET}}$ not asserted, $\overline{\text{MR}}$, $\overline{\text{RESET}}$, C_T open.	-	3.0	6.0	μA
V_{OL}	Low level output voltage	$1.3\text{V} \leq V_{DD} < 1.8\text{V}$, $I_{OL}=0.4\text{mA}$	-	-	0.3	V
		$1.8\text{V} \leq V_{DD} \leq 6.5\text{V}$, $I_{OL}=1.0\text{mA}$	-	-	0.4	
V_{POR}	Power-up reset voltage *	$V_{OL}=0.2\text{V}$, $I_{\text{RESET}}=15\mu\text{A}$	-	-	1.0	V
V_{IT}	Negative-going input threshold accuracy	PT7M3808G01	-2.0	± 1.0	+2.0	%
		$V_{IT} \leq 3.3\text{V}$	-1.5	± 0.5	+1.5	
		$3.3\text{V} < V_{IT} \leq 5.0\text{V}$	-2.0	± 1.0	+2.0	
V_{HYS}	Hysteresis on V_{IT} pin	PT7M3808G01	-	1.5	3.0	% V_{IT}
		Fixed versions		1	2.5	
$R_{\overline{\text{MR}}}$	$\overline{\text{MR}}$ Internal pull-up resistance		70	90	-	$\text{k}\Omega$
I_{SENSE}	Input current at SENSE pin	PT7M3808G01 $V_{\text{SENSE}}=V_{IT}$	-25		25	nA
		Fixed versions $V_{\text{SENSE}}=6.5\text{V}$	-	1.8	-	μA
I_{OH}	$\overline{\text{RESET}}$ Leakage Current	$V_{\text{RESET}}=6.5\text{V}$, $\overline{\text{RESET}}$ not asserted	-		300	nA
C_{IN}	Input capacitance, any pin	C_T pin $V_{IN}=0\text{V}$ to V_{DD}	-	5	-	pF
		Other pins $V_{IN}=0\text{V}$ to 6.5V	-	5	-	
V_{IL}	$\overline{\text{MR}}$ logic low input	-	0		$0.3V_{DD}$	V
V_{IH}	$\overline{\text{MR}}$ logic High input	-	$0.7V_{DD}$		V_{DD}	V
t_w	Input pulse width to $\overline{\text{RESET}}$	SENSE $V_{IH}=1.05V_{IT}$, $V_{IL}=0.95V_{IT}$	-	20	-	μs
		$\overline{\text{MR}}$ $V_{IH}=0.7V_{DD}$, $V_{IL}=0.3V_{DD}$	-	0.001	-	μs
t_D	$\overline{\text{RESET}}$ delay time	$C_T=\text{open}$	12	20	28	ms
		$C_T=V_{DD}$	180	300	420	ms
		$C_T=100\text{pF}$	0.75	1.25	1.75	ms
		$C_T=180\text{nF}$	0.7	1.2	1.7	s
t_{pHL}	Propagation delay	$\overline{\text{MR}}$ to $\overline{\text{RESET}}$ $V_{IH}=0.7V_{DD}$, $V_{IL}=0.3V_{DD}$	-	150	-	ns
	High to low level $\overline{\text{RESET}}$ delay	SENSE to $\overline{\text{RESET}}$ $V_{IH}=1.05V_{IT}$, $V_{IL}=0.95V_{IT}$	-	20	-	us

Note: The lowest supply voltage (V_{DD}) at which $\overline{\text{RESET}}$ becomes active. $\text{Trise}(V_{DD}) \geq 15\mu\text{s}/V$.

Timing Diagram

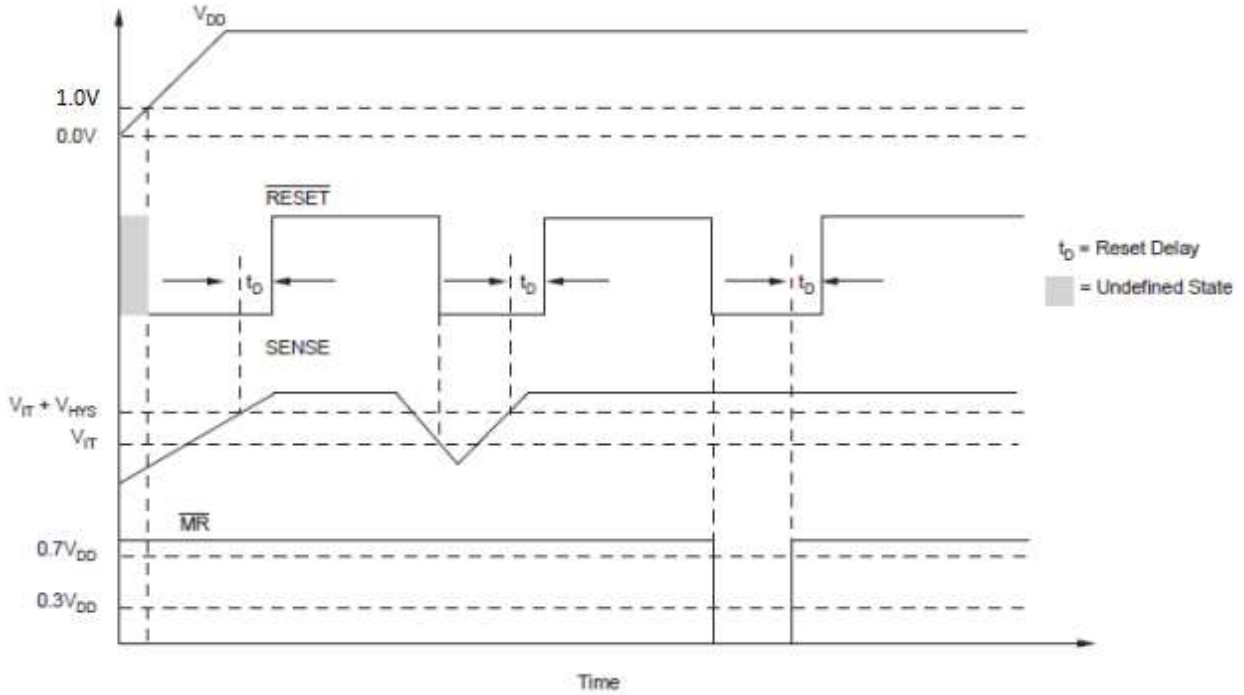

Truth Table

\overline{MR}	SENSE > V_{IT}	\overline{RESET}
L	0	L
L	1	L
H	0	L
H	1	H

Typical application circuit

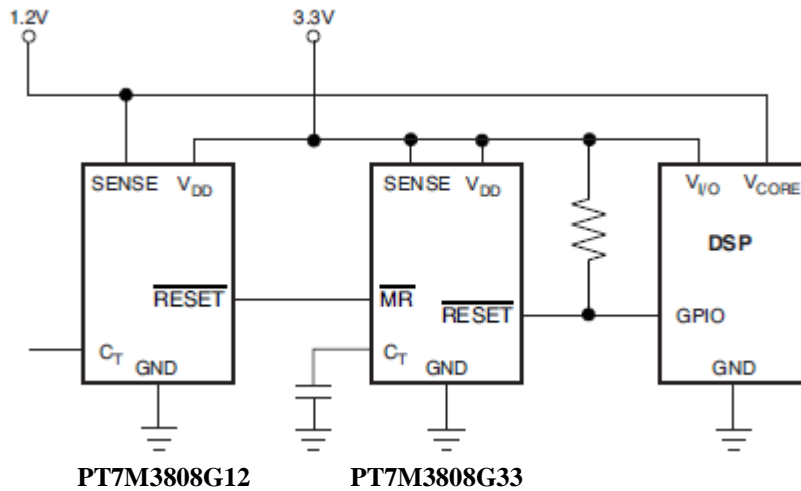

Functional Description

The PT7M3808 microprocessor supervisory product family is designed to assert a $\overline{\text{RESET}}$ signal when either the SENSE pin voltage drops below V_{IT} or the manual reset ($\overline{\text{MR}}$) is driven low. The $\overline{\text{RESET}}$ output remains asserted for a user-adjustable time after both the manual reset ($\overline{\text{MR}}$) and SENSE voltages return above the respective thresholds. A broad range of the voltage threshold and reset delay time adjustments are available, allowing these devices to be used in a wide array of applications. Reset threshold voltages can be factory-set from 0.82V to 3.3V or from 4.4V to 5.0V, while the PT7M3808G01 can be set to any voltage above 0.405V using an external resistor divider. Two preset delay times are also user-selectable: connecting the C_T pin to V_{DD} results in a 300ms reset delay, while leaving the C_T pin open yields a 20ms reset delay. In addition, connecting a capacitor between C_T and GND allows the designer to select any reset delay period from 1.25ms to 10s.

RESET Output

The open-drain $\overline{\text{RESET}}$ output is typically connected to the $\overline{\text{RESET}}$ input of a microprocessor. A pull-up resistor must be used to hold this line high when $\overline{\text{RESET}}$ is not asserted. The $\overline{\text{RESET}}$ output is undefined for voltage below 1.0V, but this is normally not a problem since most microprocessors do not function below this voltage. $\overline{\text{RESET}}$ remains high (unasserted) as long as SENSE is above its threshold (V_{IT}) and the manual reset ($\overline{\text{MR}}$) is logic high. If either SENSE falls below V_{IT} or $\overline{\text{MR}}$ is driven low, $\overline{\text{RESET}}$ is asserted, driving the $\overline{\text{RESET}}$ pin to low impedance.

Once $\overline{\text{MR}}$ is again logic high and SENSE is above $V_{IT} + V_{HYS}$ (the threshold hysteresis), a delay circuit is enabled which holds $\overline{\text{RESET}}$ low for a specified reset delay period. Once the reset delay has expired, the $\overline{\text{RESET}}$ pin goes to a high impedance state. The pull-up resistor from the open-drain $\overline{\text{RESET}}$ to the supply line can be used to allow the reset signal for the microprocessor to have a voltage higher than V_{DD} (up to 6.5V). The pull-up resistor should be no smaller than 10k Ω as a result of the finite impedance of the $\overline{\text{RESET}}$ line.

SENSE Input

The SENSE input provides a pin at which any system voltage can be monitored. If the voltage on this pin drops below V_{IT} , then $\overline{\text{RESET}}$ is asserted. The comparator has a built-in hysteresis to ensure smooth $\overline{\text{RESET}}$ assertions and de-assertions. It is good analog design practice to put a 1nF to 10nF bypass capacitor on the SENSE input to reduce sensitivity to transients and layout parasitic.

The PT7M3808G01 can be used to monitor any voltage rail down to 0.405V by resistor divider.

Manual Reset ($\overline{\text{MR}}$) Input

The manual reset ($\overline{\text{MR}}$) input allows a processor or other logic circuits to initiate a reset. A logic low ($0.3V_{DD}$) on $\overline{\text{MR}}$ will cause $\overline{\text{RESET}}$ to assert. After $\overline{\text{MR}}$ returns to a logic high and SENSE is above its reset threshold, $\overline{\text{RESET}}$ is de-asserted after the user defined reset delay expires. Note that $\overline{\text{MR}}$ is internally tied to V_{DD} using a 90k Ω resistor so this pin can be left unconnected if $\overline{\text{MR}}$ will not be used. Do not apply voltage level over V_{DD} .

Selecting the RESET Delay Time

The PT7M3808 has three options for setting the $\overline{\text{RESET}}$ delay time.

1. A fixed 300ms typical delay time by tying C_T to V_{DD} through a resistor from 40k Ω to 200k Ω . As below Figure (a) shown.
2. A fixed 20ms delay time by leaving the C_T pin open. As below Figure (b) shown.
3. A ground referenced capacitor connected to C_T for a user-defined program time between 1.25ms and 10s. The capacitor C_T should be $\geq 100\text{pF}$ nominal value in order for the PT7M3808xxx to recognize that the capacitor is present. The capacitor value for a given delay time can be calculated using the following equation: $C_T(\text{nF}) = [t_D(\text{s}) - 0.5 \times 10^{-3}(\text{s})] \times 175$. As below Figure (c) shown.

The reset delay time is determined by the time it takes an on-chip precision 220nA current source to charge the external capacitor to 1.23V. When a $\overline{\text{RESET}}$ is asserted the capacitor is discharged. When the $\overline{\text{RESET}}$ conditions are cleared, the internal current source is enabled and begins to charge the external capacitor. When the voltage on this capacitor reaches 1.23V, $\overline{\text{RESET}}$ is de-asserted. Note that a low leakage type capacitor such as a ceramic should be used and the stray capacitance around this pin may cause errors in the reset delay time.

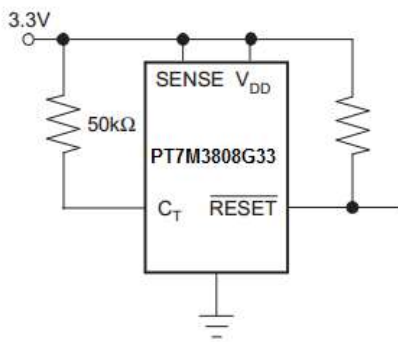

300ms Delay

(a)

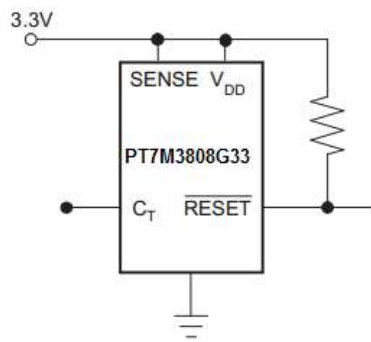

20ms Delay

(b)

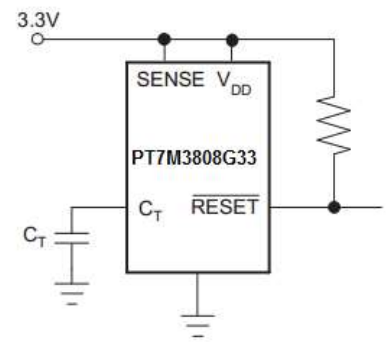

$$\text{Delay (s)} = \frac{C_T \text{ (nF)}}{175} + 0.5 \times 10^{-3} \text{ (s)}$$

(c)

Mechanical Information

TDFN2.0x2.0-6L

TOP VIEW

BOTTOM VIEW

RECOMMENDED LAND PATTERN(unit:mm)

SIDE VIEW

PKG. DIMENSIONS(MM)		
SYMBOL	Min	Max
A	0.70	0.80
A1	0.00	0.05
A3	0.20 REF	
D	2.00 BSC	
E	2.00 BSC	
D1	1.10	1.30
E1	0.60	0.80
b	0.20	0.30
L	0.27	0.43
e	0.65 BSC	

Note:
1. Ref: JEDEC MO-287A

		DATE: 12/09/13
DESCRIPTION: 6-Pin, TDFN, 2X2		
PACKAGE CODE: ZC (ZC6)		
DOCUMENT CONTROL #: PD-2178	REVISION: --	

PT7M3808

SOT23-6L

PKG. DIMENSIONS(MM)		
SYMBOL	Min	Max
A	1.05	1.25
A1	0.00	0.10
A2	1.05	1.15
b	0.30	0.50
c	0.10	0.20
D	2.82	3.02
E	1.50	1.70
E1	2.65	2.95
e	0.95 BSC	
e1	1.80	2.00
L	0.30	0.80
theta	0°	8°

Note:
1. Ref: JEDEC MO-178C/AB

PERICOM Enabling Serial Connectivity	DATE: 06/18/13
DESCRIPTION: 6-Pin, Small Outline Transistor Plastic Package (SOT23)	
PACKAGE CODE: TA (TA6)	
DOCUMENT CONTROL #: PD-2145	REVISION:--

Ordering Information

Part No.	Package Code	Package
PT7M3808GxxxZCE	ZC	6-pin, 2.0x2.0 (TDFN)
PT7M3808GxxxZCEX	ZC	6-pin, 2.0x2.0 (TDFN), Tape & Reel
PT7M3808Gxxx TAE	TA	6-pin, Small Outline Transistor Plastic Package (SOT23)
PT7M3808Gxxx TAEX	TA	6-pin, Small Outline Transistor Plastic Package (SOT23), Tape & Reel

Note:

- E = Pb-free and Green
- Adding X Suffix= Tape/Reel
- xxx shows different function, see below *Function Comparison Table*.

Function Comparison Table

Product	Nominal Supply Voltage	SENSE Threshold Voltage(V_{IT})
PT7M3808G01	adjustable	0.405V
PT7M3808G09	0.9V	0.84V
PT7M3808G12	1.2V	1.12V
PT7M3808G125	1.25V	1.16V
PT7M3808G15	1.5V	1.40V
PT7M3808G18	1.8V	1.67V
PT7M3808G19	1.9V	1.77V
PT7M3808G25	2.5V	2.33V
PT7M3808G30	3.0V	2.79V
PT7M3808G33	3.3V	3.07V
PT7M3808G50	5.0V	4.65V

IMPORTANT NOTICE

DIODES INCORPORATED MAKES NO WARRANTY OF ANY KIND, EXPRESS OR IMPLIED, WITH REGARDS TO THIS DOCUMENT, INCLUDING, BUT NOT LIMITED TO, THE IMPLIED WARRANTIES OF MERCHANTABILITY AND FITNESS FOR A PARTICULAR PURPOSE (AND THEIR EQUIVALENTS UNDER THE LAWS OF ANY JURISDICTION).

Diodes Incorporated and its subsidiaries reserve the right to make modifications, enhancements, improvements, corrections or other changes without further notice to this document and any product described herein. Diodes Incorporated does not assume any liability arising out of the application or use of this document or any product described herein; neither does Diodes Incorporated convey any license under its patent or trademark rights, nor the rights of others. Any Customer or user of this document or products described herein in such applications shall assume all risks of such use and will agree to hold Diodes Incorporated and all the companies whose products are represented on Diodes Incorporated website, harmless against all damages.

Diodes Incorporated does not warrant or accept any liability whatsoever in respect of any products purchased through unauthorized sales channel. Should Customers purchase or use Diodes Incorporated products for any unintended or unauthorized application, Customers shall indemnify and hold Diodes Incorporated and its representatives harmless against all claims, damages, expenses, and attorney fees arising out of, directly or indirectly, any claim of personal injury or death associated with such unintended or unauthorized application.

Products described herein may be covered by one or more United States, international or foreign patents pending. Product names and markings noted herein may also be covered by one or more United States, international or foreign trademarks.

This document is written in English but may be translated into multiple languages for reference. Only the English version of this document is the final and determinative format released by Diodes Incorporated.

LIFE SUPPORT

Diodes Incorporated products are specifically not authorized for use as critical components in life support devices or systems without the express written approval of the Chief Executive Officer of Diodes Incorporated. As used herein:

A. Life support devices or systems are devices or systems which:

1. are intended to implant into the body, or
2. support or sustain life and whose failure to perform when properly used in accordance with instructions for use provided in the labeling can be reasonably expected to result in significant injury to the user.

B. A critical component is any component in a life support device or system whose failure to perform can be reasonably expected to cause the failure of the life support device or to affect its safety or effectiveness.

Customers represent that they have all necessary expertise in the safety and regulatory ramifications of their life support devices or systems, and acknowledge and agree that they are solely responsible for all legal, regulatory and safety-related requirements concerning their products and any use of Diodes Incorporated products in such safety-critical, life support devices or systems, notwithstanding any devices- or systems-related information or support that may be provided by Diodes Incorporated. Further, Customers must fully indemnify Diodes Incorporated and its representatives against any damages arising out of the use of Diodes Incorporated products in such safety-critical, life support devices or systems.

Copyright © 2016, Diodes Incorporated

www.diodes.com

X-ON Electronics

Largest Supplier of Electrical and Electronic Components

Click to view similar products for [Supervisory Circuits](#) category:

Click to view products by [Diodes Incorporated](#) manufacturer:

Other Similar products are found below :

[CAT1161LI-25-G](#) [CAT853STBI-T3](#) [CAT1026LI-30-G](#) [CAT1320LI-25-G](#) [TC54VN2402EMB713](#) [MCP1316T-44NE/OT](#) [MCP1316MT-45GE/OT](#) [MCP1316MT-23LI/OT](#) [MAX8997EWW+](#) [MAX6725AKASYD3-LF-T](#) [DS1232L](#) [NCV302HSN45T1G](#) [PT7M6130NLTA3EX](#) [PT7M7811STBEX-2017](#) [S-1000N28-I4T1U](#) [CAT1161LI-28-G](#) [MCP1321T-29AE/OT](#) [MCP1319MT-47QE/OT](#) [S-1000N23-I4T1U](#) [S-1000N19-I4T1U](#) [CAT824UTDI-GT3](#) [TC54VC2502ECB713](#) [PT7M6133NLTA3EX](#) [PT7M6127NLTA3EX](#) [AP0809ES3-r](#) [HG811RM4/TR](#) [MD7030C](#) [MD7033C](#) [MD7019](#) [MD7020](#) [MD7021](#) [MD7023](#) [MD7024](#) [MD7027](#) [MD7030](#) [MD7033](#) [MD7035](#) [MD7036](#) [MD7039](#) [MD7040](#) [MD7044](#) [MD7050](#) [MD7015](#) [MD7022](#) [MD7028](#) [MD7031](#) [MD7042](#) [MD7043](#) [MD7047](#) [MD7060](#)