

Supervisory Circuit

Features

- Highly accurate: $\pm 1.5\%$ (25 °C)
- Accurate power monitoring: 2.5V, 2.9V, 3.0V (PT7M1818), and 4.1, 4.3, 4.6V (PT7M1813)
- Operating voltage range: 1.0V ~ 5.5V
- Operating temperature range: -40 °C to + 85 °C
- Detect voltage temperature characteristics: $\pm 2.5\% \times \text{TYP}$
- Efficient open-drain output with internal 5k Ω pull-up resistor
- Maintains reset for 200ms after V_{CC} returns to an in-tolerance condition

Description

The series are designed to monitor power supplies in μP and digital systems. It provides excellent circuit reliability and low cost by eliminating external components and adjustments.

This device performs a single function: it asserts a reset signal whenever the V_{CC} supply voltage falls below a preset threshold. Reset remains asserted for 200ms after V_{CC} has risen above the reset threshold.

PT7M1818/1813 are bidirectional output, allowing it to be directly connected to μP with bidirectional reset inputs.

Pin Configuration

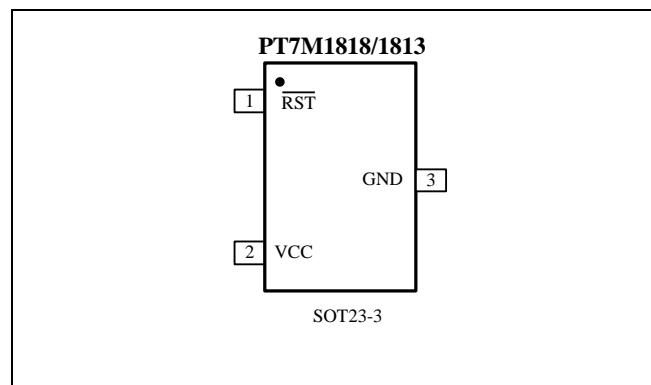

Pin Description

Name	Type	Description
$\overline{\text{RST}}$	I/O	Reset Output and Pushbutton Input: $\overline{\text{RST}}$ is asserted when V_{CC} drops below voltage threshold V_{TH} . Active low. When other devices pull $\overline{\text{RST}}$ low, the reset condition occurs and will remain a reset timeout period after the external signal is off.
GND	P	Ground
V_{CC}	P	Supply Voltage.

Maximum Ratings

Storage Temperature	-65°C to +150°C
Ambient Temperature with Power Applied.....	-40°C to +85°C
Supply Voltage to Ground Potential (V _{CC} to GND)	-0.3V to +7.0V
DC Input Voltage (All inputs except V _{CC} and GND).....	-0.3V to V _{CC} +0.3V
DC Output Current (All outputs)	30mA
Power Dissipation	320mW (Depend on package)

Note:

Stresses greater than those listed under MAXIMUM RATINGS may cause permanent damage to the device. This is a stress rating only and functional operation of the device at these or any other conditions above those indicated in the operational sections of this specification is not implied. Exposure to absolute maximum rating conditions for extended periods may affect reliability.

DC Electrical Characteristics

(T_A = -40~85 °C, unless otherwise noted. Typical values are at T_A = +25 °C)

Description	Sym.	Test Conditions	Min	Typ	Max	Unit	
Supply Voltage	V _{CC}		1.0	-	5.5	V	
Supply Current	I _{CC}	V _{CC} = 5.5V. No load.	-	-	12	μA	
		V _{CC} = 3.6V. No load.	-	-	10	μA	
Voltage Threshold	V _{TH-}	+25°C	(V _{TH-}) ×0.985	V _{TH-}	(V _{TH-}) ×1.015	V	
		-40°C~85°C	(V _{TH-}) ×0.975	V _{TH-}	(V _{TH-}) ×1.025	V	
Hysteresis	V _{HYS}	V _{TH+} - V _{TH-} *	-	50	-	mV	
Output Driving	Output low	V _{OL}	I _{OH} = 8mA, V _{CC} = 5V	-	-	0.4	V
			I _{OH} = 4mA, V _{CC} = 3V	-	-	0.3	
			I _{OH} = -50 μA, V _{CC} = 1V	-	-	0.09	
Internal pull-up resistor	R _p	\overline{RST}	3.75	5	6.25	kΩ	

Note: V_{TH-} is voltage threshold when V_{CC} falls from high to low. V_{TH+} is voltage threshold when V_{CC} rises from low to high.

AC Electrical Characteristics

Fig 1. Timing diagram

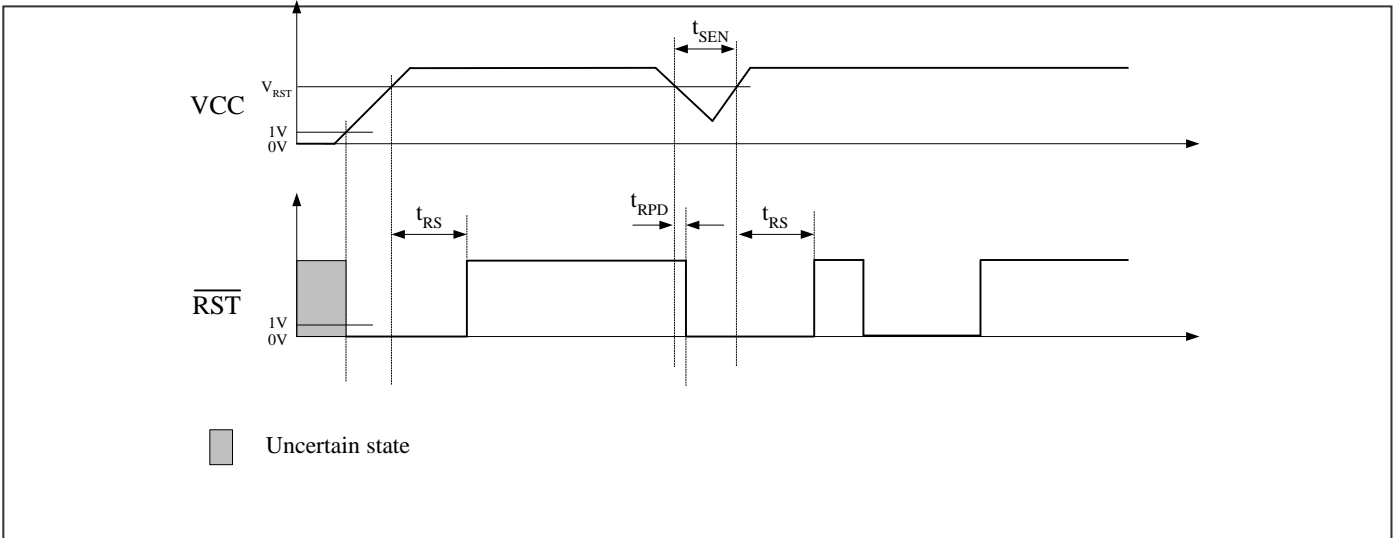
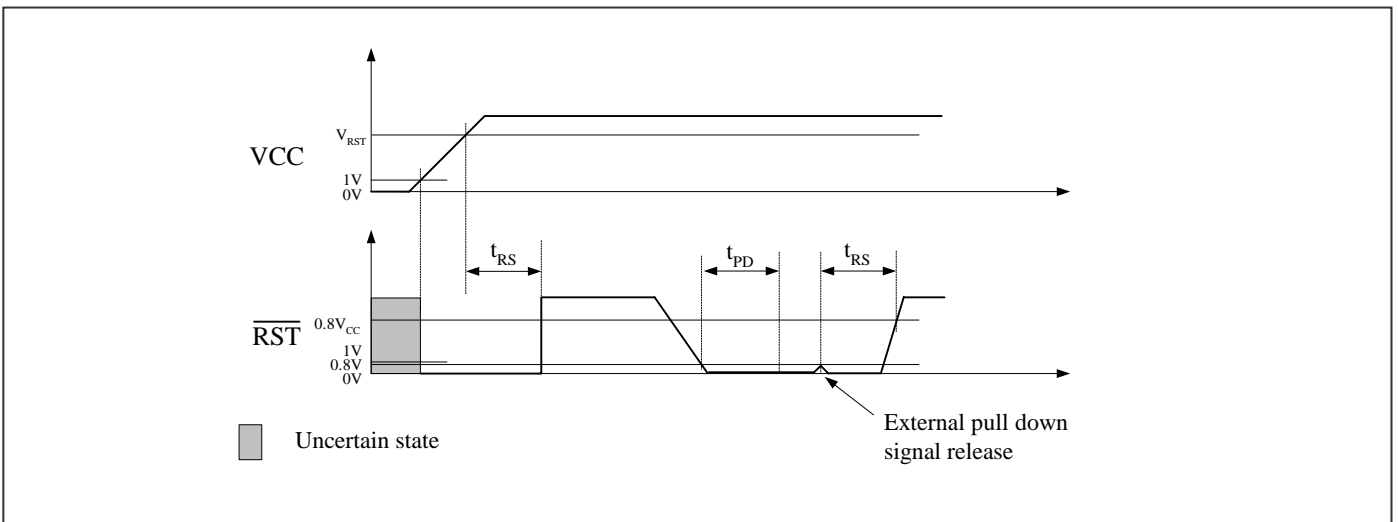

Fig 2. Timing diagram



($V_{CC} = 1.0V$ to $5.5V$, $T_A = -40\sim 85\text{ }^\circ\text{C}$, unless otherwise noted. Typical values are at $T_A = +25\text{ }^\circ\text{C}$)

Sym.	Description	Test Conditions	Min	Typ	Max	Unit
t_{RS}	Reset Timeout Period	-	140	200	280	ms
t_{RPD}	Delay	-	-	17	-	μs
t_{SEN}	Sensitivity	-	20	-	-	μs
t_{PD}	External Pull Down Signal Pulse	$\overline{\text{RST}}$ pin	1	-	-	μs
	Pushbutton Detect*	$\overline{\text{RST}}$ pin	0.8	1.5	2.0	V

*Note: $\overline{\text{RST}}$ will be asserted when it is pull down to the typical value or less.

Block Diagram

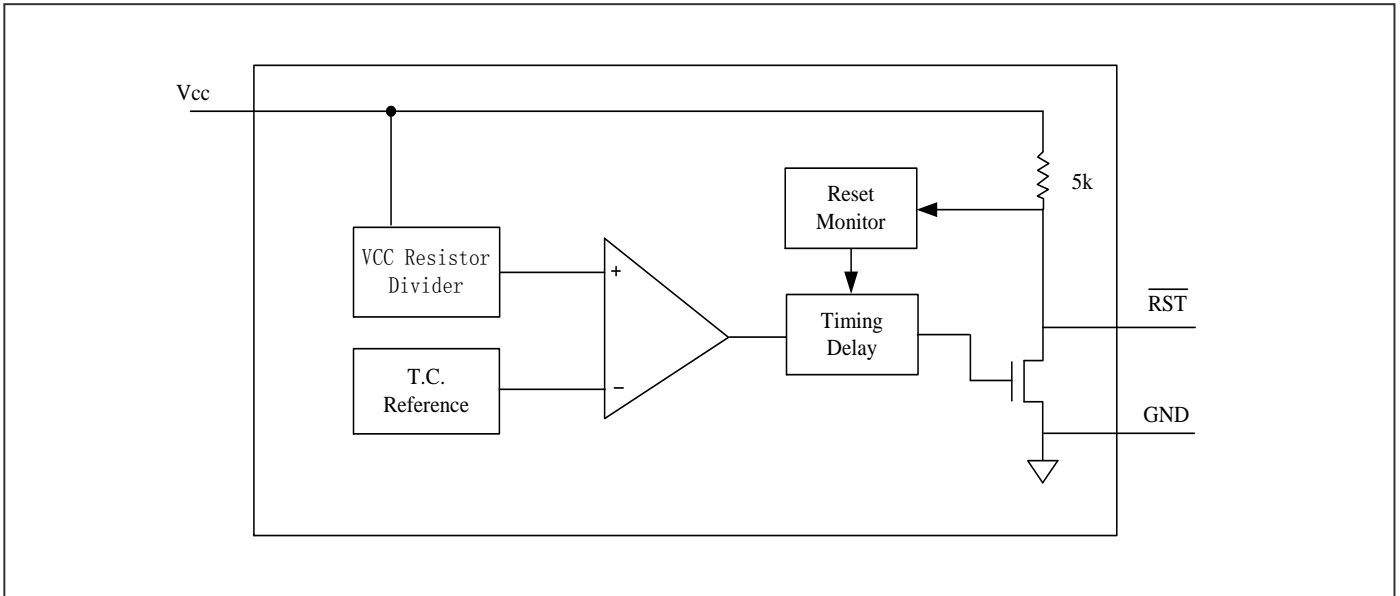

Function Description

Power Monitor

A microprocessor's (μP 's) reset input starts the μP in a known state. Whenever the μP is in an unknown state, it should be held in reset. The supervisory circuits assert reset during power-up and prevent code execution errors during power-down or brownout conditions.

On power-up, once V_{cc} reaches about 1.0V, $\overline{\text{RST}}$ is a guaranteed logic low of 0.4V or less. As V_{cc} rises, $\overline{\text{RST}}$ stays low. When V_{cc} rises above the reset threshold V_{RST} , an internal timer releases $\overline{\text{RST}}$ after about 200ms. $\overline{\text{RST}}$ asserts whenever V_{cc} drops below the reset threshold, i.e. brownout condition. If brownout occurs in the middle of a previously initiated reset pulse, the pulse continues for at least another 200ms. On power-down, once V_{cc} falls below the reset threshold, $\overline{\text{RST}}$ stays low and is guaranteed to be 0.4V or less until V_{cc} drops below 1V.

Reset Output: Bi-direction

The devices provide $\overline{\text{RST}}$ output pin for a pushbutton switch. When the devices are not in a reset cycle, it continuously monitors the $\overline{\text{RST}}$ signal for a low going edge. If an edge is detected, the devices will debounce the switch by pulling the $\overline{\text{RST}}$ line low. After the internal timer has expired, the devices will continue to monitor the $\overline{\text{RST}}$ line. If the line is still low, they will continue to monitor the line looking for a rising edge. Upon detecting a release, they will force the $\overline{\text{RST}}$ line low and hold it low for 200ms.

Application Information

Typical Operation Circuit

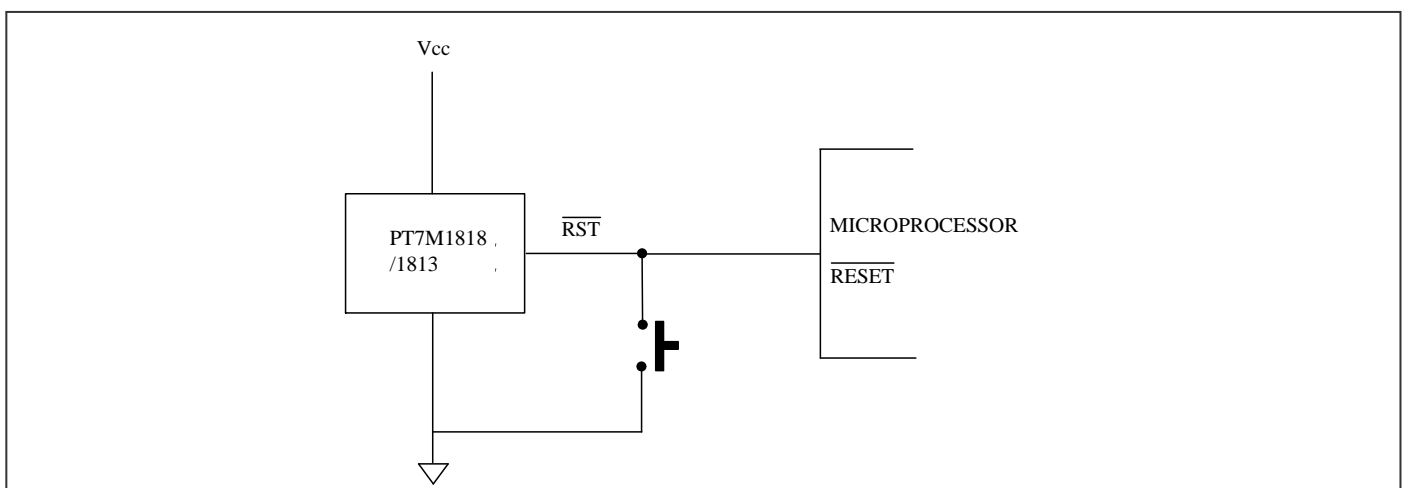

Mechanical Information

SOT23-3

DOCUMENT CONTROL NO.

PD-0018

REVISION: A

DATE: 5/17/2011

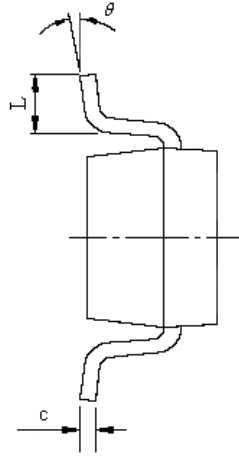
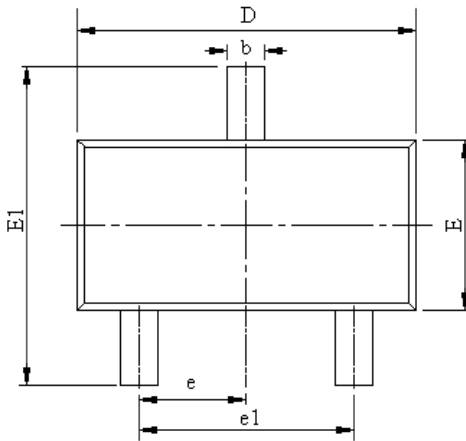

PKG. DIMENSIONS(MM)		
SYMBOL	MIN	MAX
A	1.05	1.25
A1	0.00	0.10
A2	1.05	1.15
b	0.30	0.50
c	0.10	0.20
D	2.82	3.02
E	1.50	1.70
E1	2.65	2.95
e	0.95BSC	
e1	1.80	2.00
L	0.30	0.60
θ	0°	8°

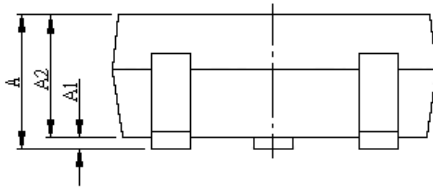

Note:

1) Controlling dimensions in millimeters.

Pericom Technology (Shanghai) Co.Ltd.
3/F., 20 Building, 481 Gui Ping Road,
Shanghai, 200233
Tel: (86-21)6485-0576. Fax: (86-21)6485-2181

DESCRIPTION: 3-Pin Small Outline Transistor, Plastic Package, SOT-23

PACKAGE CODE: TA3

Ordering Information

Part Number	Package Code	Package
PT7M1818-20TE	T	Lead free and Green SOT23-3
PT7M1818-10TE	T	Lead free and Green SOT23-3
PT7M1818-5TE	T	Lead free and Green SOT23-3
PT7M1813-15TE	T	Lead free and Green SOT23-3
PT7M1813-10TE	T	Lead free and Green SOT23-3
PT7M1813-5TE	T	Lead free and Green SOT23-3

Note:

- E = Pb-free or Pb-free and Green
- Adding X Suffix= Tape/Reel
- Contact Pericom for availability.

Small Package Top Marking Instruction

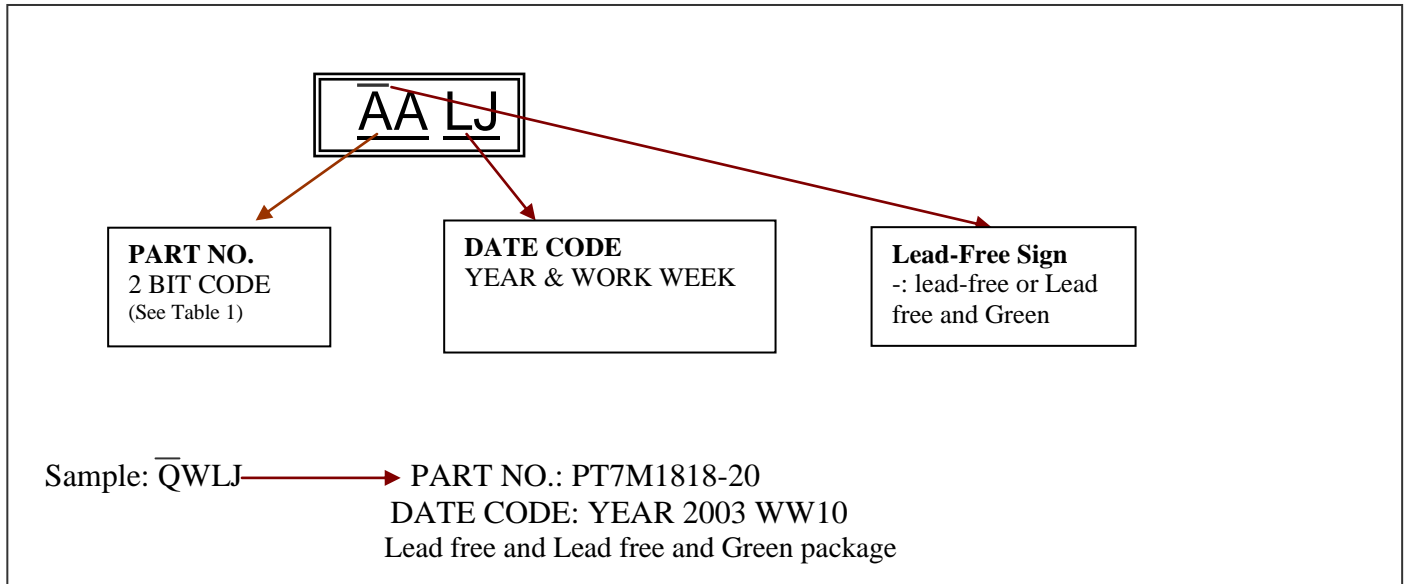

Table 1. Function comparison

Item	Part No.	Reset Output					V _{TH} (V)
		Open-Drain		Push-Pull		Bi-direct	
		Active high	Active low	Active high	Active low	Active low	
1	PT7M1818-20	-	-	-	-	√	2.5
2	PT7M1818-10	-	-	-	-	√	2.9
3	PT7M1818-5	-	-	-	-	√	3.0
4	PT7M1813-15	-	-	-	-	√	4.1
5	PT7M1813-10	-	-	-	-	√	4.3
6	PT7M1813-5	-	-	-	-	√	4.6

Table 2 Marking code for products

No.	Part No.	Code
1	PT7M1818-20	QW
2	PT7M1818-10	RA
3	PT7M1818-5	RB
4	PT7M1813-15	RL
5	PT7M1813-10	RO
6	PT7M1813-5	RR

Pericom Semiconductor Corporation • 1-800-435-2336 • www.pericom.com

Pericom reserves the right to make changes to its products or specifications at any time, without notice, in order to improve design or performance and to supply the best possible product. Pericom does not assume any responsibility for use of any circuitry described other than the circuitry embodied in Pericom product. The company makes no representations that circuitry described herein is free from patent infringement or other rights, of Pericom.

X-ON Electronics

Largest Supplier of Electrical and Electronic Components

Click to view similar products for [Supervisory Circuits](#) category:

Click to view products by [Diodes Incorporated](#) manufacturer:

Other Similar products are found below :

[NCP304LSQ38T1G](#) [NCP304LSQ40T1G](#) [NCP304LSQ42T1G](#) [NCP304LSQ43T1G](#) [NCP304LSQ46T1G](#) [NCP305LSQ11T1G](#)
[NCP305LSQ16T1G](#) [NCP305LSQ17T1G](#) [NCP305LSQ18T1G](#) [NCP305LSQ24T1G](#) [NCP305LSQ25T1G](#) [NCP305LSQ29T1G](#)
[NCP305LSQ31T1G](#) [NCP305LSQ32T1G](#) [NCP308MT250TBG](#) [NCP308SN300T1G](#) [NCP391FCALT2G](#) [NCV303LSN42T1G](#)
[NCV308SN330T1G](#) [CAT1161LI-25-G](#) [CAT853STBI-T3](#) [MAX1232CPA](#) [MAX705CPA](#) [CAT1026LI-30-G](#) [CAT1320LI-25-G](#) [CAT872-30ULGT3](#) [LA-ispPAC-POWR1014-01TN48E](#) [NCP304HSQ18T1G](#) [NCP304HSQ29T1G](#) [NCP304LSQ27T1G](#) [NCP304LSQ29T1G](#)
[NCP304LSQ45T1G](#) [NCP305LSQ26T1G](#) [NCP305LSQ35T1G](#) [NCP305LSQ37T1G](#) [NCP308MT300TBG](#) [NCV300LSN36T1G](#)
[NCV302LSN30T1G](#) [NCV303LSN16T1G](#) [NCV303LSN22T1G](#) [NCV303LSN27T1G](#) [NCV33161DMR2G](#) [TC54VN2402EMB713](#)
[MCP1316T-44NE/OT](#) [MCP1316MT-45GE/OT](#) [MCP1316MT-23LI/OT](#) [MCP1316T-26LE/OT](#) [MAX8997EWW+](#) [MAX821RUS+T](#)
[MAX6725AKASYD3-LF-T](#)